

Roll-A-Print

(Models RAP-1400, 2800)

Thermal Transfer Print Station

Operation Guide, Version 1B

Setup, Operation and Parts Manual

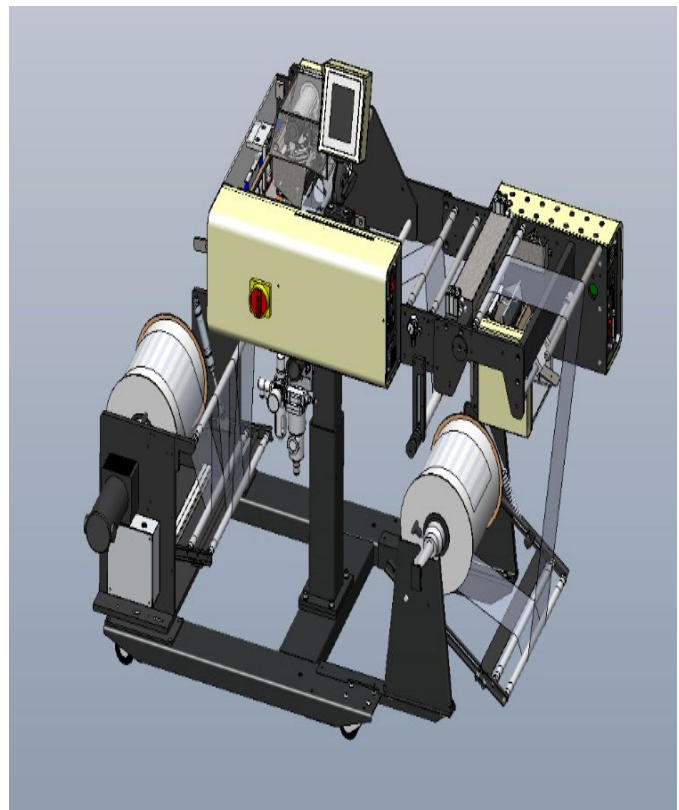
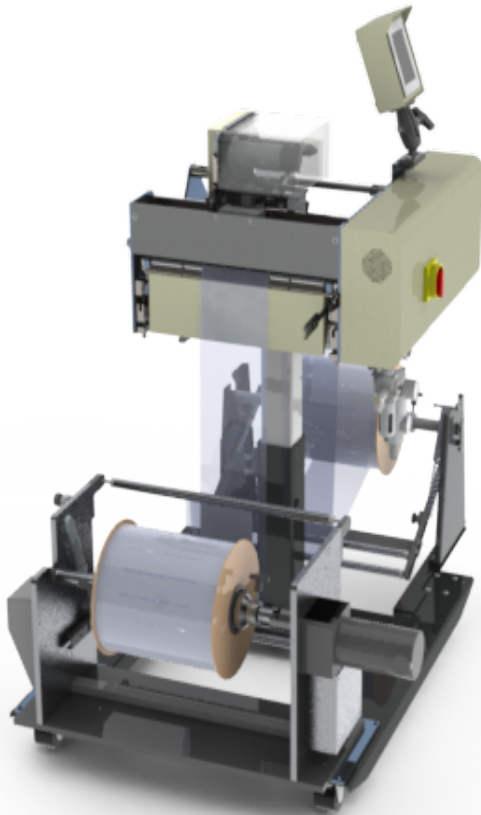

 **Advanced
Poly-Packaging, Inc.**

1331 Emmitt Road • Akron, OH 44306 • 1-800-754-4403 • fax 330-785-4010 • www.advancedpoly.com

Acknowledgments

Written by: Annie Braddock, Updated by David Kolinski-Schultz

Reviewed by: Stuart Baker

Copyright

2019 (Ver 1B), 2014 (Ver 1A), Advanced Poly-Packaging, Inc. (APPI). All rights reserved.

This manual and the program operating the equipment described in it are copyrighted. You may not copy this manual in whole or part without the consent of Advanced Poly-Packaging, Inc.

All information pertaining to the promotion, sale, distribution, operation, and maintenance of the Roll-a-Print including this manual, drawings, schematic, wiring diagrams, video, brochures, specification sheets, figures, charts, or any other information, due to its proprietary design and manufacture remain the property of Advanced Poly Packaging, Inc. Unauthorized duplication, distribution or disclosure to third parties without the express permission of Advanced Poly-Packaging, Inc. is strictly prohibited.

Trademarks

Roll-a-Print is a trademark of Advanced Poly-Packaging, Inc. Advanced Poly-Packaging, Inc. owns also the following trademarks: Advanced Poly-Bags, Advanced Poly-Bagger, Seal-a-Print, Roll-a-Print, Twin-Seal, Advanced Poly-Pack, Advanced Poly-Bag, Advanced Bag.

Limited Warranty and Disclaimer

Warranty period is 12 months or 1,000,000 cycles whichever comes first. The warranty commences on the date of delivery of the equipment to the Purchaser. APPI warrants to the Purchaser that the equipment is free from defects in workmanship or material under normal use and service. During the warranty period, APPI agrees to repair or replace, at its sole option, without charge to Purchaser, any defective component part of the equipment. To obtain service, Purchaser must return the equipment or component to APPI or an authorized APPI distributor or service representative in an adequate container for shipping. Any shipping charges, insurance, or other fees must be paid by Purchaser and all risk for the equipment shall remain with Purchaser until such time as APPI takes receipt of the equipment. Upon receipt, APPI, the authorized distributor or service representative will promptly repair or replace the defective component and then return the equipment or component to Purchaser, shipping charges, insurance, and additional fees prepaid. APPI may use reconditioned or like new parts or units, at its sole option, when repairing any component or equipment. Repaired products shall carry the same amount of outstanding warranty as from original purchase. Any claim under the warranty must include a dated proof of delivery. In any event, APPI's liability for defective components or equipment is limited to repairing or replacing the components. This warranty is contingent upon proper use of the equipment by Purchaser and does not cover: expendable component part such thermocouple wire, heater cartridge, rollers, bushings, and the like; or if damage is due to accident, unusual physical, electrical or electromechanical stress, neglect, misuse, failure of electric power, water damage (from airlines), improper environmental conditions, transportation, tampering with or altering of the equipment, packaging of corrosive or contaminating products or other products damaging to components, and equipment or components not owned or in the possession of original Purchaser. APPI will not be liable for loss of production, profits, lost savings, special, incidental, consequential, indirect, or other similar damages arising from breach of warranty, breach of contract, negligence, or their legal action even if APPI or its agent has been advised of the possibility of such damages or for any claim brought against the Purchaser by another party. This warranty allocates risks of equipment failure between Purchaser and APPI. APPI's pricing reflects this allocation of risk and the limitations of liability contained in this warranty. The warranty set forth above is in lieu of all other express warranties, whether oral or written. The agents, employees, distributors, and dealers of APPI are not authorized to make modifications to this warranty, or additional warranties binding on APPI. Accordingly, additional statements such as dealer advertising or presentations, whether oral or written, do not constitute warranties by APPI and should not be relied upon. Warranty on equipment is considered void when outstanding balances become delinquent (over 30 days late - 60 days after ship date). Equipment Integration to other Equipment: APPI assumes no responsibility for the integration of its products to other products or within a system unless APPI performs the integration, testing and provides the results of the tests to the purchaser in writing. Furthermore, APPI assumes no responsibility for bag sizing whether suggested or recommended.

TABLE OF CONTENTS

Chapter 1: Introduction	6
1.1 Welcome.....	7
1.2 Overview	7
1.3 Special Features.....	7
1.4 Using This Manual: Typographical Conventions	7
1.5 Contact Information	8
1.6 Warranty Registration	9
Chapter 2: Safety, Getting Started	10
2.1 Summary	11
2.2 Safety, Risks.....	11
2.3 Installation Procedures	12
2.4 Air and Power Requirements	12
2.5 Air and Power Hookup.....	13
2.6 Main Power	13
2.7 Threading Diagram	13
2.8 Note on Adjustments to the Roll-a-Print.....	13
Chapter 3: Touch Screen Operation	18
3.1 Summary	19
3.2 Touch Screen Program.....	19
3.3 Introduction Screen	19
3.4 Main Menu	19
3.5 Printer Settings Screen	20
3.6 Printer Operation	21
3.7 Label Position.....	21
3.8 Punch Setup.....	22
3.9 Bag Open Detector	23
3.10 Stored Labels.....	23
3.11 Counters	24
3.12 Job Save.....	24

3.13	Technical Assistance	24
3.14	Password Setup Screen.....	25
3.15	Factory Settings.....	26
3.16	Printer Status Screen	27
3.17	PLC I/O Screens.....	27
3.18	Alarm History.....	28
3.19	Production Timers	28
3.20	Bagger Production Graph.....	29
3.21	Perf Registration.....	29
3.22	Warning and Message Screens.....	30
Chapter 4: Adjustments, Maintenance and Troubleshooting		32
<hr/>		
4.1	Pinch Roller Alignment / Film Tracking.....	33
4.2	Roller Web Guides	33
4.3	Print Position (Left / Right Adjustment).....	34
4.4	PLC IO Listing.....	34
4.5	Preventative Maintenance	35
Chapter 5: Parts and Drawings		36
<hr/>		
5.1	Roll-A-Print 1400 System Layout.....	37
5.2	Stand Assembly.....	38
5.3	Dancer Assembly RAP1400.....	39
5.4	Dancer Assembly	40
5.5	Driven Wind-Up Unit.....	42
5.6	Main Body Assembly.....	44
5.7	Air Knife Assembly	47
5.8	IOP Assembly	48
5.9	Electronics Assembly.....	49
5.10	Zebra Roll-A-Print Assembly	52
5.11	Four Inch Printer Sub-Assembly.....	54
5.12	Bag Out Detector Assembly.....	57
5.13	Electronics Assembly (8" Print Head Model).....	58
5.14	Electronics Assembly Detail	59
5.15	Eight Inch Printer Assembly	61
5.16	Roll-A-Print 2800 System Layout.....	64
5.17	Ti-1000Z Inline Thermal Printer.....	66

5.18 Mounting Assembly 67
5.19 Nip Roll Assembly 69
5.20 Printer Register 71
5.21 Notes 73

This page intentionally left blank.

Chapter 1: Introduction

Welcome

Overview

Special Features

Using This Manual: Typographical Conventions

Contact Information

Warranty Registration

1.1 Welcome

Now that you've decided to upgrade your packaging facilities with the Roll-a-Print Thermal Transfer Print Station, we thank you for selecting our equipment, materials, and service. Where labor reduction and fast changeover is important, the Roll-a-Print feeds Advanced Poly-Bags, flat film or tubing manufactured by Advanced Poly-Packaging, Inc.

1.2 Overview

The Roll-a-Print is designed to lower your printing costs with high speeds, versatility, reliability, and simplicity.

- **High Speeds:** Prints at rates up to 10" per second (depending on the level of detail in the print, print/font size and materials).
- **Versatility:** Designed to print on a variety of films including polyethylene, polypropylene, laminated films, foils, and various other materials. Different ribbon may be required based on the type of material.
- **Reliability:** Crafted from the highest quality components and materials to withstand the most rigorous manufacturing environment. Sturdy mounts and rugged frame guarantee long life and usefulness with minimal maintenance.
- **Simplicity:** A user-friendly, menu-driven touch screen program allows operators to set up the printer, save the settings in memory and recall those settings for repeat runs.

1.3 Special Features

Energy Conservation and Component Saver: To extend its life and conserve energy in your plant, the Roll-a-Print is programmed to sequentially shut components down when not in use for extended periods. Air flow can also be shut off preserving compressed air. Finally, a screen saver is provided to extend the life of the touch screen.

Pass Code Protection: Setting screens can be protected from alteration by unauthorized individuals. Once turned on, this function acts as a "screen save" feature. A timer causes the pass code screen to be displayed, preventing access to settings screen. Factory settings are protected by a Level One pass code and should only be provided to maintenance personnel.

Predetermined Counter: Preset the Roll-a-Print to stop after a predetermined number of print cycles. Set the quantity of finished bags to complete a work order or fill a shipping container. Once the work order is complete or the container is full, the Roll-a-Print stops to alert the operator to begin the next work order or to push aside the box to begin filling another. Pressing Reset on the screen resets the counter and starts the bagging operation with minimum delay.

Totalizing Counter: Reset this counter at the beginning of each shift or day to record printing production over a period of time.

1.4 Using This Manual: Typographical Conventions

This manual functions as one manual for several model printers. Some sections of these chapters will only apply to a specific printer. These sections will be properly noted. The following manual conventions are frequently used to assist in understanding important information, to alert the operator of potentially dangerous or damaging practices and to describe the normal functions of the Roll-a-Print.

- Text Normal text.
- **BOLDFACE** Used to identify heading names and touch screen buttons.
- **CAUTION:** Warning messages. To avoid physical harm, damage to equipment or damage to the product, be sure to read these messages carefully.
- **NOTE:** Identifies important information.

1.5 Contact Information

To better serve your bagging needs, call **(330) 785-4000** or toll free **1-(800) 754-4403** for convenient service solutions, Monday through Thursday, 9:00 AM to 5:30 PM EST, or Friday 9:00 AM to 5:00 PM EST. For technical assistance with current machinery, ask for **Service**. To order spare parts for your system, ask for **Parts**. To order auxiliary equipment for your current system, ask for **Machine Sales**. To place an order for bags, ask for **Bag Sales**.

You may also contact any of these departments by email:

Reach Service at Service@advancedpoly.com

Reach Parts at Parts@advancedpoly.com

Reach Machine Sales at MachineSales@advancedpoly.com

Reach Bag Sales at Bagsales@advancedpoly.com

For general inquires: Sales@advancedpoly.com

Or visit us online at www.advancedpoly.com

In order to provide the best service possible, please have model and serial number ready.

1.6 Warranty Registration

This section must be completed and returned to Advanced Poly Packaging, Inc. to register the Roll-a-Print for Warranty Protection.

Roll-A-Print Serial Number:

(Serial Number located on the back panel)

Company Name and Address

Contact Name(s) / Title(s) / Phone Number

<hr/> <hr/> <hr/> <hr/>	<hr/> <hr/> <hr/> <hr/>
-------------------------	-------------------------

Please fax or mail this page to:

Service Manager
Advanced Poly-Packaging, Inc.
1331 Emmitt Road
Akron, OH 44306
USA

Fax # (USA) 330-785-4010

Or email the information above to: service@advancedpoly.com

Chapter 2: Safety, Getting Started

Summary

Safety, Risks

Installation Procedures

Air and Power Requirements

Air and Power Hookup

Main Power

Threading Diagram

Note on Adjustments to the Roll-a-Print

2.1 Summary

This chapter describes in detail procedures to receive and setup the Roll-a-Print, including uncrating, environmental, air and power requirements, and assembly and height adjustments. Additionally, this chapter describes how to turn on power to the Roll-a-Print, properly thread bags through the machine, and properly thread the ribbon through the printer.

2.2 Safety, Risks

The equipment has been designed with features to reduce the possibility of injury. Despite safety precautions, operators may receive lacerations, minor burns or crushed or broken bone injuries if coming in contact with the heater bar or other moving components. Please carefully read the following precautions to operate the equipment properly and avoid injury.

Although no special personal protective equipment is required to operate the equipment, eye protection, gloves or other protection should be worn depending on the characteristics of product being packaged or the method of loading the product.

Please carefully read the following precautions to operate the equipment properly and avoid injury:

CAUTION: Initial Setup of the machine must be performed by Specialized Personnel. Qualified Service Engineers should uncrate, assemble (if required), test and connect power sources, test the equipment for proper operation and otherwise setup the equipment for use.

CAUTION: Maintenance must be performed by Specialized Personnel. Qualified Service Engineers must remove guards or covers to gain access to electrical or mechanical areas.

CAUTION: To avoid injury do not reach under the equipment or guards. Do not place hands or fingers in the seal area, near the seal or heater bar, load shelf, or other moving components.

CAUTION: To avoid injury, do not operate the equipment if funnels, guards, or covers or other access panels have been removed. If any of these safety measures have been removed or modified or if any openings have been increased, the operator will have access to moving components and extreme temperature areas that can cause crush, cut, or burn injuries to hands or fingers.

CAUTION: To avoid injury, do not reach under guards or elsewhere under the machine.

CAUTION: Do not remove or loosen fasteners on the frame. If loosened the equipment may drop suddenly causing injury or damage to the machine.

CAUTION: Do not attempt to adjust the height without assistance and without supporting the weight of the machine. Attempting to make a height adjustment without assistance could cause the machine to drop suddenly, causing severe injury. APPI offers several optional accessories that can reduce the risk of injury during height adjustments. These accessories include carts, motorized height adjustment components and stabilizing bars.

CAUTION: Ensure that any height adjustments allow for sufficient movement of the operator. Improper height adjustments could negatively affect operator movement, causing strain, added stress, discomfort, and fatigue.

CAUTION: Be careful when opening the seal frame as it may drop suddenly causing injury or damage to the equipment.

CAUTION: To avoid injury, avoid coming in contact with pinch points including rollers, automatic funnel doors or other moving components.

CAUTION: To avoid injury, avoid contact with Roller "Fingers" as they may be sharp.

CAUTION: Exercise care when adjusting or relocating the touch screen. Movement of the touch screen could cause unexpected movement of the machine and injury to the operator.

CAUTION: If control or air pressure settings are set too high, higher noise levels may result from increased part on part contact or part on machinery contact. Limit these settings and add guards or covers to reduce airborne noise.

CAUTION: Exercise extreme care when clearing jams, replacing materials, changing controls or mechanical settings, and cleaning internal parts. Be sure to de-energize energy sources prior to removing guarding. Failure to do so may result in unexpected movement or flying objects, which could cause crush, cut, or eye injuries.

CAUTION: Maintenance must be performed by specialized personnel. Qualified service engineers must remove guards or covers to gain access to electrical or mechanical areas.

CAUTION: Maintenance must be performed regularly to ensure that the machine is operating properly and to protect against injury. Routine maintenance includes: periodic inspections, the replacement of worn or damaged components, the tightening of loose bolts or components, and regular cleaning and adjustments. Contact APPI and/or service centers for service support if there is not sufficient maintenance staff at your facility to perform regular maintenance.

2.3 Installation Procedures

The Roll-a-Print is shipped completely assembled and in a carton or crate. Remove all tape, banding or packing materials that secure the machine. To ensure the highest production possible, consider product flow to the printer and packaged product flow away from the printer when positioning the unit into your packaging areas. The Roll-a-Print should be placed in an area free of excessive heat, moisture, dirt, and dust. Operating room temperature should range from 50 to 100° Fahrenheit (10 to 38° Celsius).

2.4 Air and Power Requirements

Power Requirements: Provision must be made for 110 VAC, 60 Hz line current with ground. Optional 220V/50hz voltage may have been supplied based on your local electrical requirements. The full load current for the Roll-a-Print is 10 Amps.

CAUTION: A qualified electrician should ensure that the Roll-a-Print power outlet is properly grounded, voltages are as required and amperage capacity is sufficient.

NOTE: APPI recommends a dedicated 20 Amp circuit for the Roll-a-Print.

Air Requirements: At least 1 CFM free air is required, regulated to 40 PSI (2.76 BAR). Air should be dry and oil-free

NOTE: Running the Roll-a-Print at a higher PSI setting than 40 PSI (2.76 BAR) will cause excessive wear and may cause damage to components on the printer.

2.5 Air and Power Hookup

This section describes in detail how to hook up air and power and the air and power requirements.

NOTE: A qualified electrician should ensure power outlets are the required voltage and properly grounded before hooking up the power.

The air supply should be fed to the Roll-a-Print with 3/8 ID flexible tubing; this tubing affixes to the coupler adapter (quick disconnect not provided). Connect the air to the regulator by holding the regulator firmly in one hand and pushing the air line connector on the male regulator connector. After connecting air, the regulator should be adjusted so the gauge reads 40 PSI (2.76 BAR).

2.6 Main Power

The main power switch is located on the side cover of the machine. To turn the machine on, turn the switch clockwise from the horizontal OFF position to the vertical ON position. The green Power light on the touch screen will illuminate and the Introduction screen will be displayed. The program version will also be identified. The Introduction screen will only appear for a few seconds until automatically changing to the Printer Settings screen.

2.7 Threading Diagram

The following diagrams are provided to demonstrate the web path for threading bags through the machines as well as how to thread the ribbon through the print head. See Figure 2- 1 through Figure 2- 3

NOTE: The RAP2800 uses the print head depicted in figure 2-3 turned upside down for the TIZ hang behind printer.

NOTE: The RAP1400-08Z uses the same print head diagram as the RAP1400 and the RAP2800, it just uses 8" rollers in length instead of 4" rollers.

2.8 Note on Adjustments to the Roll-a-Print

Upon receipt, it is not unusual for the Roll-a-Print to be out of alignment due to shipping and excessive handling. Unless physically damaged, the Roll-a-Print will function properly after minor adjustments are accomplished. Refer to Chapter 4 for information on adjustments to the Roll-a-Print.

ROLL-A-PRINT 1400 & ROLL-A-PRINT 1400-08Z THREADING DIAGRAM

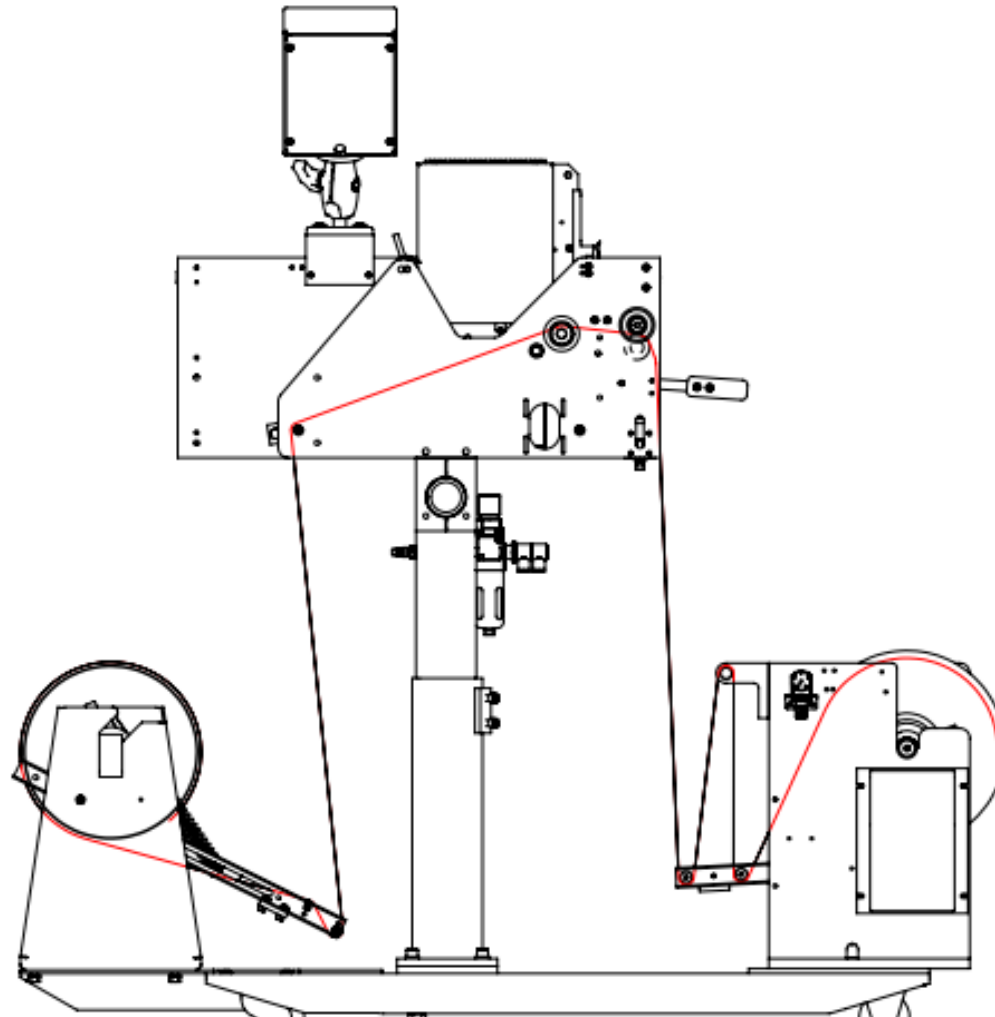

Figure 2- 1

ROLL-A-PRINT 2800 THREADING DIAGRAM

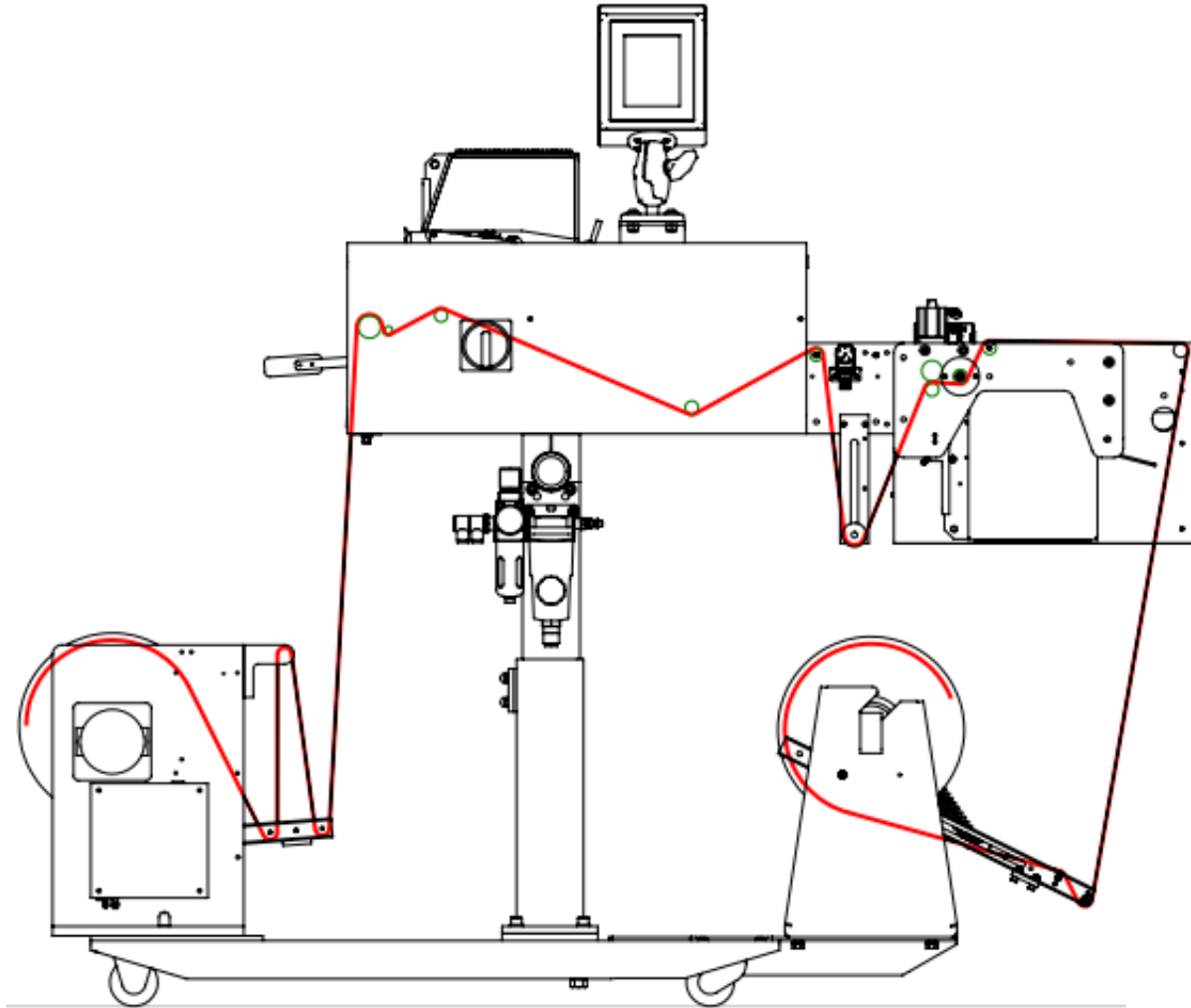

Figure 2-2

ROLL-A-PRINT 1400 & ROLL-A-PRINT 2800 PRINT HEAD THREADING DIAGRAM

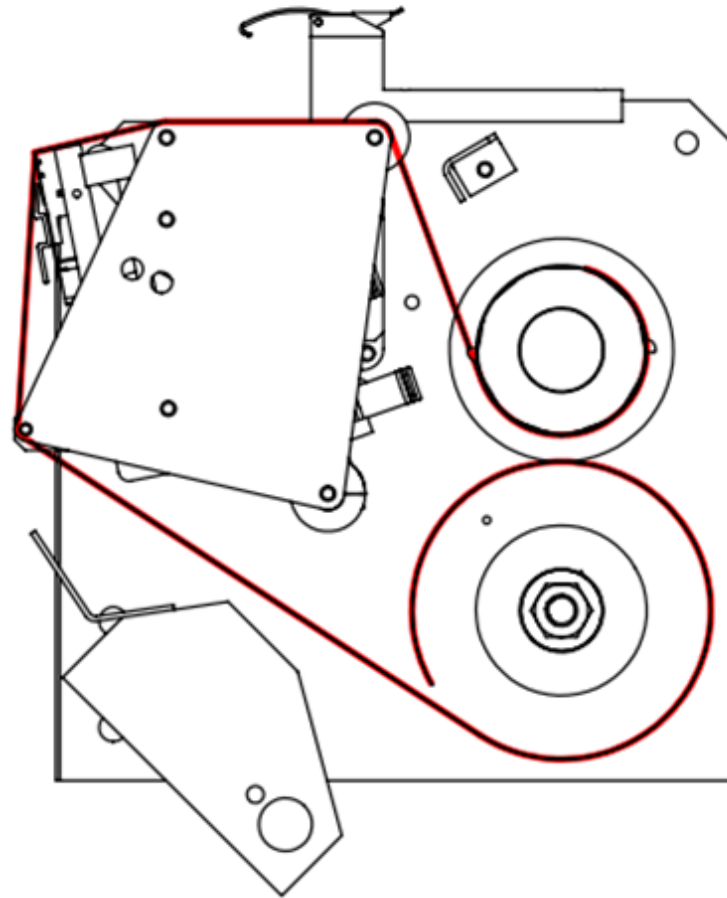

Figure 2-3

This page intentionally left blank.

Chapter 3: Touch Screen Operation

Summary

Touch Screen Program

Introduction Screen

Main Menu

Printer Settings Screen

Printer Operation

Label Position

Punch Setup

Bag Open Detector

Stored Labels

Counters

Job Save

Technical Assistance

Password Setup Screen

Factory Settings

Printer Status Screen

PLC I/O Screens

Alarm History

Production Timers

Bagger Production Graph

Perf Registration

Warning and Message Screens

3.1 Summary

This section describes the identification, operation, and adjustments of the touch screen program for all three APPI Roll-a-Prints. All three Roll-a-Prints use the same operation program. The following sections apply to all three machines.

3.2 Touch Screen Program

The touch screen program is a user-friendly, menu-driven setup and operation program. Popup windows are incorporated for quick and easy setting adjustments. A general color scheme has been used for consistency with operation:

- **Blue:** Background color used for text information. No “buttons” or functions are blue.
- **Green:** Used for buttons that change settings. For example, pressing a green button may display a pop-up window or turn a function on / off.
- **Red:** Indicates that a function is off or stopped. For example, pressing a red button may turn a function on.
- **Yellow:** Used for menu buttons. Pressing a menu button displays another screen and allows for movement throughout the entire program.



Figure 3- 1

3.3 Introduction Screen

When the Roll-a-Print is turned on, an Introduction screen is displayed See Figure 3- 1. The Introduction screen functions as a welcome screen, and pressing the Operation button takes you to the Main Menu.

3.4 Main Menu

The Main Menu screen allows the operator to quickly navigate to other areas in the program. See Figure 3- 2. Mode Toggle Buttons are located at the top of many screens:

- **START / STOP:** This button controls the operation mode, the mode that allows the equipment to cycle. Press the **STOP** button to change the button to **START** and begin operation. Press the **START** button to change the button to **STOP** and stop operation.
- **MANL / AUTO:** This button can be pressed to enter the machine into either Automatic or Manual mode. Press the **MANL** button to switch to Automatic mode. Press the **AUTO** button to switch to Manual mode. Automatic mode allows the machine to cycle automatically. Manual mode requires the operator to press the **MC** (Manual Cycle) button to cycle the machine.

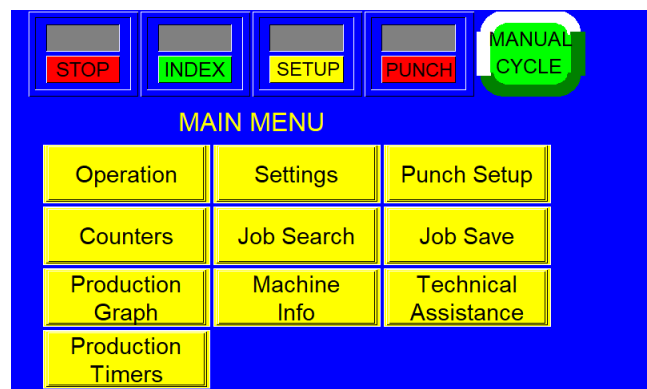

Figure 3- 2

- **Printer ON / Printer OFF:** This button turns the printer on and off. Press the **Printer ON** button to change the button to Printer OFF and turn the printer off. Press the **Printer OFF** button to change the button to Printer ON and turn the printer on.
- **Punch / Punch:** This button toggles from Red to Green and activates the optional **Punch Assembly**.

3.5 Printer Settings Screen

The Printer Settings screen displays the printer's status and allows for settings adjustment. See Figure 3- 3 .

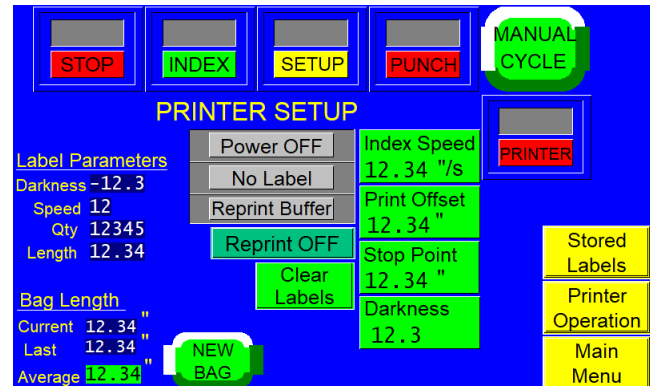

Figure 3- 3

Index Speed: Index Speed is the speed, in inches per second, at which the bag will feed /index into position. To adjust this setting, press the **Index Speed** button, enter a value into the numeric keypad and press the **ENT** button.

Darkness: Darkness can be set between 1 and 30. Darkness settings can be set in your label software, but can also be overridden by adjusting the Darkness setting on the Printer Settings screen. Increase the Darkness setting to improve print quality. A typical setting is 20. To adjust this setting, press the **Darkness** button, enter a value into the numeric keypad and press the **ENT** button.

Print Offset: Print Offset is a delay setting that causes the print to be raised on the bag. Increasing this setting will cause loss of production. To adjust this setting, press the **PrintOffset** button, enter a value into the numeric keypad and press the **ENT** button.

Stop Point: The distance, in inches, the bag stops at after being read by the sensor. To adjust this setting, press the **StopPoint** button, enter a value into the numeric keypad and press the **ENT** button.

Press the **Reprint ON / Reprint OFF** button to turn the Reprint function on and off. The Reprint function allows the operator to continuously print the same label.

The **Printer Settings** screen displays the downloaded label parameters, including the **Darkness** setting, the **Speed** setting, the **Quantity** setting and the **Length** setting. Darkness, Print Speed and Quantity are parameters set up in the label software, displayed on the Printer Settings screen for informational purposes. However, the **Darkness** setting can be changed on the **Printer Settings** screen.

This screen also displays the length of the current and previous bag, along with the average bag size. Press the **New Bag** button to reset the currently downloaded label.

The **Clear Labels** button can clear the downloaded label format or the label format that is recalled from stored memory. Press the **Clear Error** button to clear an error with the printer and continue operation.

3.6 Printer Operation

The Printer Operation screen allows the operator to view the current printer settings and status. See Figure 3- 4

Label Quantity: Displays the number of labels remaining to be printed. This number will decrease as the printer cycles. The original label quantity value is set in the label software.

Preset Count Remaining: Displays the preset number of cycle operations left before the bagger will stop automatically. The Preset Count will count down from a preset number and stop the machine when the preset number of processed bags is reached. To adjust the Preset Count, press the right box and enter a number using the numeric keypad. The left box will then count down from that preset number.

Total Count Remaining: Displays the total number of cycle operations. To adjust the Total Count, press the right box and set it to zero. The left box will then count up and the machine will operate continuously. If the operator enters a number other than zero into the right box, the Total Count will function just like the Preset Count, and the left box will count down from that preset number.

Production Time: Displays the amount of time the machine has been turned on an operating. Press Reset

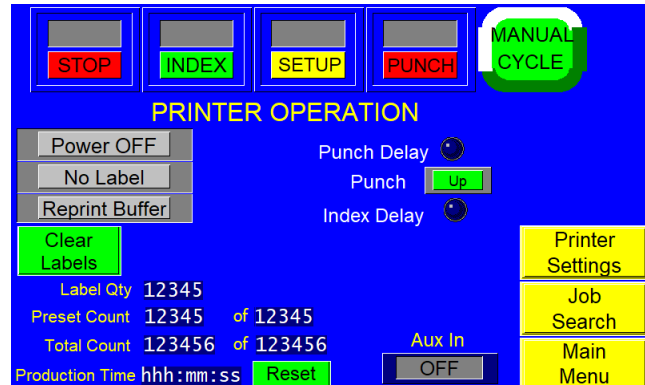

Figure 3- 4

3.7 Label Position

The Label Position screen allows the operator to view and adjust settings that affect the label position. See Figure 3- 5.

Print Offset: The Print Offset is a print delay setting that causes the print to be raised on the bag. To adjust this setting, press the Print Offset button, enter a value on the numeric keypad and press the ENT button.

Seal Point: The position of the seal, in inches, measured from the top perforation of the bag. To change this setting, press the Seal Point button, enter a value on the numeric keypad and press the ENT button.

Reverse: The distance, in inches, the rollers will reverse the bag into the T-1000-S14, while the pressure bar grips the bag, in order to break the perforation between bags. To adjust this setting, press the Reverse button, enter a value on the numeric keypad and then press the ENT button.

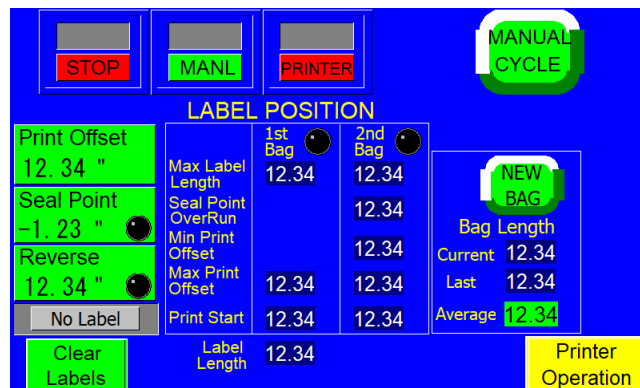

Figure 3- 5

Label Length: This setting is the same as the Length setting on the NBO Printer Setup screen. To change this setting, press the Label Length button, enter a value into the numeric keypad and press the ENT button.

The Label Position screen provides detailed information for two methods of printing: first bag printing and second bag printing. Second bag printing allows a larger area of the bag to be printed. The blue box in the center of the screen displays several label settings for the first and second bag that affect the label position and are automatically calculated based on the label length. These settings include:

- Max Label Length: The maximum, acceptable length of the label.
- Seal Point Overrun: The amount of bag beyond the seal point that is printed. The bag will reverse to the seal point once the machine has finished printing.
- Min Print Offset: The minimum amount the print can be raised on the bag.
- Max Print Offset: The maximum amount the print can be raised on the bag.
- Print Start: The location where the printer begins printing.

The LEDs at the top of the 1st Bag and 2nd Bag column indicate whether the settings for that method of printing are acceptable. If one LED is green, the settings for that method of printing are acceptable. If one LED is Red, the settings for that method of printing exceeded the acceptable parameters. If both LEDs are green, the settings for both methods are acceptable. If both LEDs are red, the print will likely cross over from the first bag onto the second bag, printing a portion on both bags.

Press the New Bag button after switching bag size to count the bags and start an internal program that calculates average bag length. The perforation is used for registration. If a perforation is not detected, the bag will stop in the correct seal position, based on the average bag length measurement. A Feed Error message will be displayed if the perforation is not detected within the accepted bag length range.

3.8 Punch Setup

Allows the setup of an optional Punch Assembly that can produce slits, registered to the bag, in a specific configuration. Additional programming is required to actuate the optional Punch Assembly in the correct sequence. Figure 3- 6.

Toggling the “ON/OFF” control also toggles the Mode Toggle Punch Control from Red to Green.

Selecting a control brings up a Numeric Keypad allowing the variable to be input within available parameters.

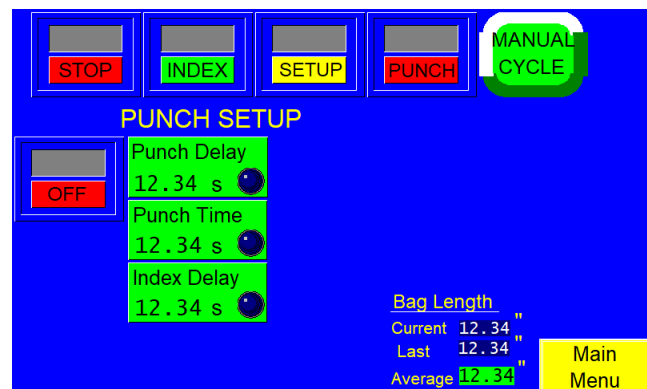

Figure 3- 6

- **Punch Delay:** Variable from 0 to 99.99 Seconds.
- **Punch Time:** Variable from 01. to 9.99 Seconds.
- **Index Delay:** Variable from 0.01 to 99.00 Seconds.

3.9 Bag Open Detector

This Photo Optic, closed contact sensor detects the opening or presence of bag material. See Figure 3- 7. This option will detect whether a bag is blown open or whether a funnel is inserted into the bag for validation that the bag is ready to receive product. The Bag Open Detector is valuable for an automatic operation to decrease the chance of product falling on the floor. To turn this option on, toggle the **ON / OFF** button to ON. See

The Bag Open Detector screen features two LEDs:

- **Blocked:** Illuminates when the sensor detects a blockage.
- **Latched:** Illuminates to indicate the sensor detected the bagger is latched.

Detect Time: The time allotted for the sensor to detect the bag before stopping the machine.

Min Time: The minimum amount of time, in seconds, the sensor has to detect the bag. A message will be displayed if the bag fails to open.

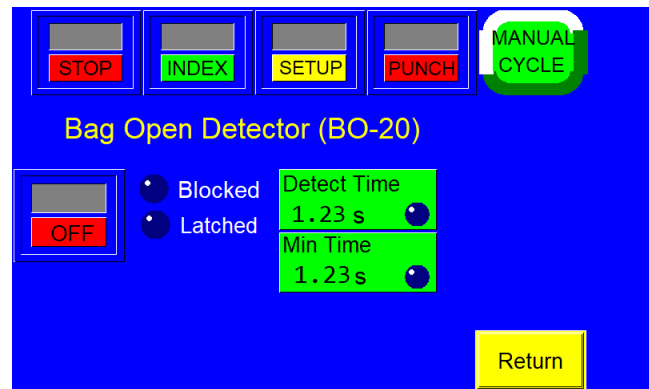

Figure 3- 7

3.10 Stored Labels

The Stored Labels screen allows for adjustment of the stored label settings. See Figure 3- 8. Many of the settings and statuses displayed on this screen also appear on the Printer Settings screen. Refer to the previous section for information on those settings.

Label #: This button allows the operator to recall a label. To recall a label, press the **Label#** button and type in a number from 001 to 999, depending on the label that you would like to recall. Enter the desired label number into the numeric keypad and press **Enter**. From the factory, APPI has included at least one sample label format (001) for testing.

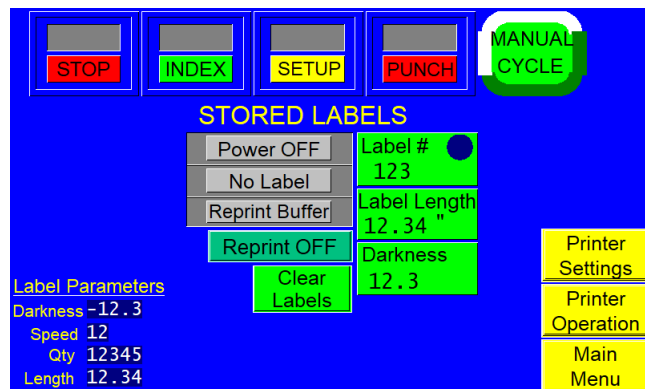

Figure 3- 8

Label Length: This setting allows the operator to adjust label length. Because the length of the label is not saved when downloading labels in memory, APPI recommends that stored labels are the same length. Otherwise, you must use a chart that describes the label format length for each stored label. To change this setting, press the **Label Length** button, enter a value into the numeric keypad and press the **ENT** button.

3.11 Counters

The Counters screen allows for adjustment of the preset and total counters. The Preset Count allows the operator to set a predetermined number of bags to be printed. Once the preset number is reached, operation will stop. The Total Count allows the operator to view the total amount of bags processed. See Figure 3- 9.

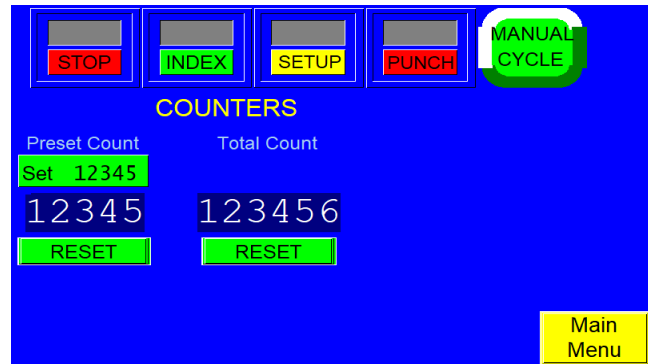

Figure 3- 9

To adjust the Preset Count, press the blue box under Preset, enter a value on the numeric keypad and press the **ENT** button. To disable the Preset Count function, set the value to zero. To adjust the Total Count, press the blue box under Total, enter a value on the numeric keypad and press the **ENT** button. Setting the Total Count to zero will display the total counts run and will not stop the system. To reset either value, press the reset Button under the respective count.

3.12 Job Save

The Roll-a-Print is able to store machine settings, called *recipes*. Each time a setting is changed on the machine, the settings are immediately saved in short-term memory so that if power is lost, the Roll-a-Print will power on with the job that was running before power was lost. See Figure 3- 10.



Figure 3- 10

To save a job to a memory location, press the **Job Save** button from the Main Menu, enter the recipe number (memory location) and then your part number. Then press the **Save** button. You will be prompted to confirm the save function.

To recall a recipe that has already been saved to a memory location, enter the recipe number, and then press the **Settings** button. You can then review the settings before pressing the **Load** button.

If you do not know the recipe number, enter your part number, then press the **Part # Search** button. You can then press the **Settings** button to view and load your settings.

NOTE: If power is lost to the printer, the downloaded labels will be lost and will require downloading again, unless the Stored Labels function is used to recall the label.

3.13 Technical Assistance

Figure 3- 11

The Technical Assistance screen provides manufacturer information, factory settings adjustments, functions testing, and troubleshooting. It also displays the program version for PLC controller and touch screen. See Figure 3- 11.



The screen is protected from access with a Level 1 pass code. The pass code is set by default (from the factory) to 1001. This code can and should be changed when the system is put into operation.

Several menu options are available from the Technical Assistance menu that will assist with troubleshooting the Roll-a-Print and change settings that affect the operation of the equipment.

Technical assistance sections of the touch screen program should be accessed by specialized personnel only. These sections are provided for troubleshooting and advanced setup by qualified service engineers.

3.14 Password Setup Screen

APPI has included a pass code function in all touch screen equipment to prevent operators from changing settings. See Figure 3- 12 .

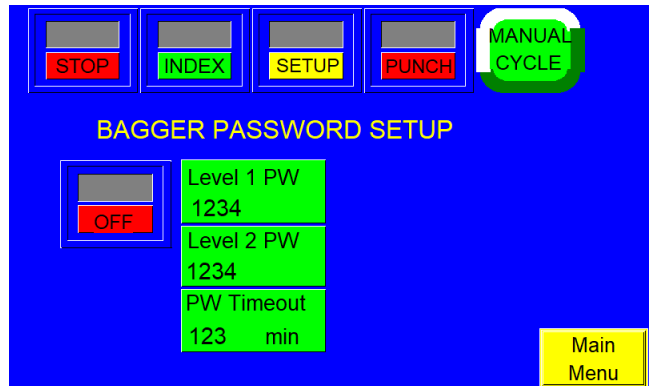

Figure 3- 12

There are two pass code levels, described as follows:

1. **Level 1:** This is the highest-level pass code. It prevents operators from accessing the Technical Assistance functions of the machine. The default pass code, when shipped from the factory, is 1001.
2. **Level 2:** This level pass code, when the pass code function is enabled, prevents the operator from accessing settings screens that affect the operation of the equipment.

Pass codes prevent unauthorized individuals from tampering with settings. When equipment is shipped, APPI uses the following factory set pass codes that should be changed prior to putting the Roll-a-Print into operation:

1. **Level 1 pass code:** 1001
2. **Level 2 pass code:** 1002

To enable the pass code function, press the **Tech Assist** button from the Main Menu: Type in the Level 1 pass code (1001 by default from APPI). Press **Bagger PassW** button to display the Password Setup Screen. Then press the **ON / OFF** toggle button to turn the pass code function ON. If you change the pass codes, ensure that these codes are written down.

Once the pass code function is enabled, the operator will have a programmed amount of time (timeout time) to make changes. Timeout time can be changed by pressing the **Timeout** button, entering a value in the numeric keypad and pressing the **ENT** button.

To change the pass codes, press the **Level1 PW** button or the **Level2 PW** button, enter a new code on the numeric keypad and press the **ENT** button.

If you misplace or forget the pass codes, contact the APPI Service Department for assistance. APPI will provide a “factory code” so that the current pass codes can be displayed. Once you receive the factory code, press the F5 function key, located to the right of the touch screen, to enter the factory code. Your current pass codes will be displayed.

3.15 Factory Settings

The Factory Settings screen contains additional settings that should only be set by qualified technicians or by the factory.

Feed Distance: This setting allows horizontal perforations that could cause the bagger to stop at the wrong location to be ignored. To adjust this setting, press the **Feed Dist** button, enter a value on the numeric keypad and press the **ENT** button. See Figure 3- 13.

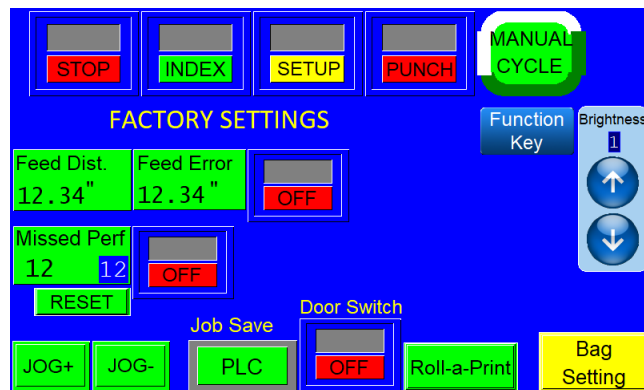

Figure 3- 13

Missed Perforation: The number of missed perforations that can occur before operation stops and an error message is displayed. To adjust this setting, press the **Miss Perf** button, enter a value on the numeric keypad and press the **ENT** button.

Feed Error: The distance, in inches, a perforation can go undetected before a Feed Error occurs and an error message is displayed. Press the **FeedErr OFF** button to turn the Feed Error function on. Press the **FeedErr ON** button to turn the Feed Error function off.

Press the **Door Switch OFF** button to turn the door switch function on. Press the **Door Switch ON** button to turn the door switch function off. The door switch function stops the RAP and displays an alarm message if any door is open.

Brightness Control. Sets brightness to 4 different levels, from “1” (dimmiest) to “4” (brightest).

Job Save: Selects where the Job information is saved: to the PLC or to a USB Drive.

Roll-a-Print / Printer: The **Print Mode** button allows for adjustment of the printer’s operation mode and for the RAP to operate as a regular, stand-alone printer. The RAP must be connected to the Bagger through the AUX3 port.

JOG+: Moves the bag forward.

JOG-: Moves the bag backward.

3.16 Printer Status Screen

The **Printer Status Screen** is used for troubleshooting the printer. See Figure 3- 14. The printer sends a status message when powered on and after each print. If the **Error** indicator illuminates, the actual error message will be displayed on the Printer Status screen.

To reset the status, press the **Clear Status** button.
 To recall the status, press the **Read Status** button.

Config Label button: Press this button to print the parameters for the printer (i.e. Darkness, Speed).

The **Head Cold ON / OFF** toggle button allows the operator to turn the **Head Cold Warning** feature on and off. If the **Head Cold Warning** feature is on, the machine will automatically stop if the print head gets too cold.

Print Config: Press this button to print the parameters for the printer.

Network Label: Press this button to print the network configuration, including the current IP address.

Printer Reset: Press this button to clear labels and start a self-test.

HeadTest Interval: The number of labels that are printed between tests. To disable this function, set the interval to zero. Press the **Head Test Reset** button to set the Head Test Interval to zero.

Bag Out: Turns the Bag Out Sensor ON / OFF.

Photo / Contact: Toggles between Contact and Photo Optic Bag Out options.

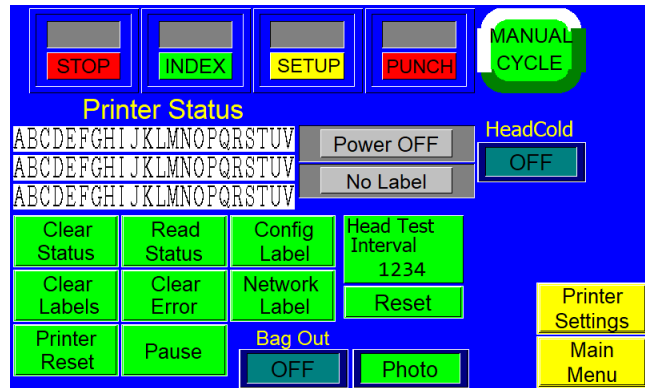

Figure 3- 14

3.17 PLC I/O Screens

The PLC I/O screens are provided for maintenance personnel to determine the status of the PLC and review the mode of outputs and inputs. PLC I/O screen(s) are also used to assist APPI Service Technicians working with your maintenance personnel to troubleshoot the Roll-a-Print in the field. See Figure 3- 15 .

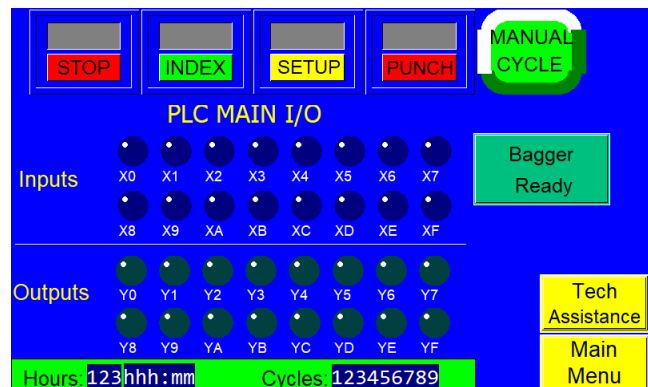

Figure 3- 15

To determine the function of each Input / Output, press the Input or Output area of the I/O Screen to display a brief description of each input or output LED. See Figure 3- 16.

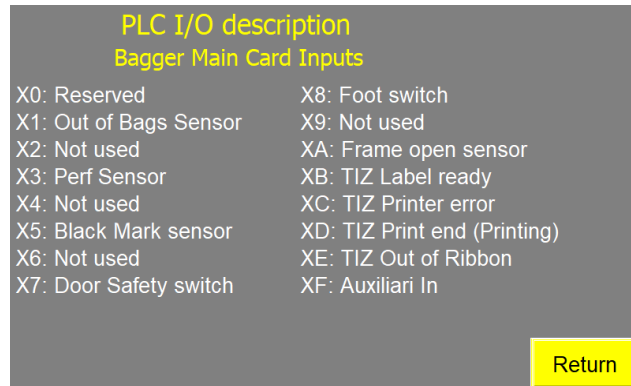

Figure 3- 16

3.18 Alarm History

The Alarm History Screens allow the operator to track all fault messages that stop operation. See Figure 3- 17 . These screens can be accessed by pressing the **Alarm History** button on the **Main Menu** screen. Selecting **Next** and/or **Previous** proceeds to additional Bagger Alarm Data Screen displaying different Alarm categories.

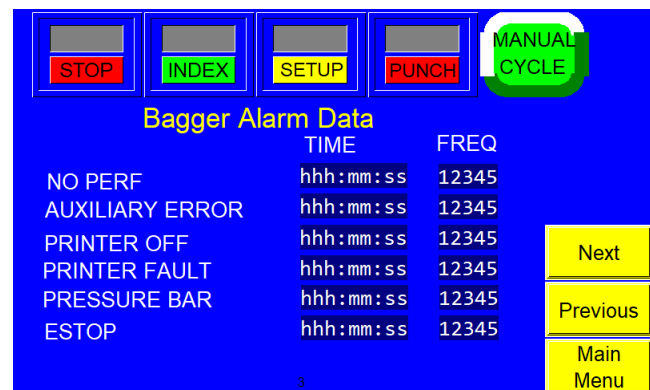

Figure 3- 17

3.19 Production Timers

Production Timers are provided to track Uptime and Downtime. Downtime can be analyzed by viewing the Alarm Data screen which sums all down time associated with each type of fault condition and counts the number of occurrences of each condition. See Figure 3- 18.

Note: Timers, Alarms and Data are automatically saved once daily by the machine, either on the internal or external memory, according to the machine setting. Each save creates a new record in the file.

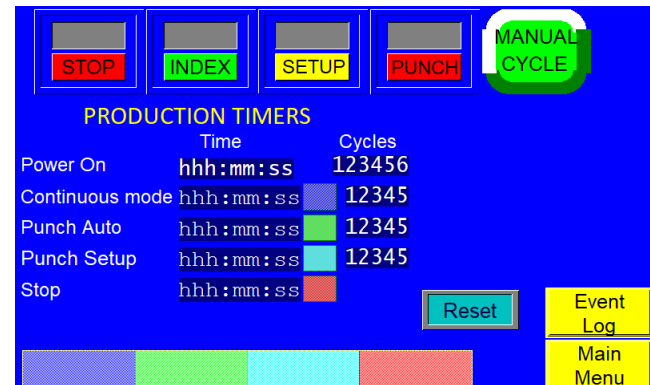

Figure 3- 18

The Production Timer Screen displays the time and frequency of the different modes of operation, including:

- **Power ON**
- **Continuous Mode**
- **Punch Auto**
- **Punch Setup**
- **Stop**

3.20 Bagger Production Graph

APPI provides a simple production graph to chart production throughout the day. See Figure 3- 19

Arrow Keys: Press the left arrow key to scroll back one hour at a time and review past production. Press the right arrow key to check more recent production information.

Reset: Press the Reset button once to reset the production time and twice to reset the graph. Press the Return button to return to the previous screen.

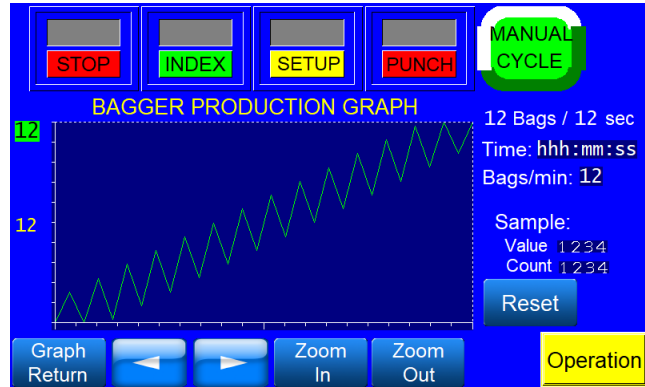

Figure 3- 19

The **Bagger Production Chart Screen** also displays the number of bags indexed per minute and the production time. See this detail in Figure 3- 20.

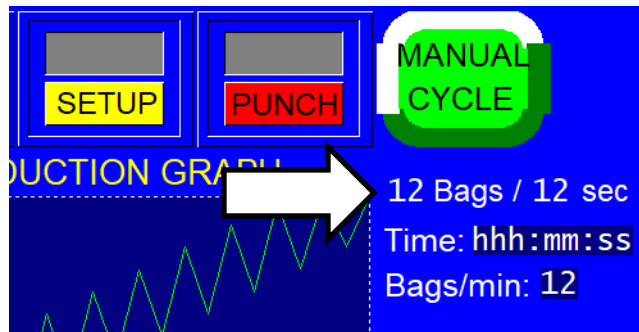

Figure 3- 20

3.21 Perf Registration

The Perf Registration screen allows the operator to set up the perforation. See Figure 3- 21

To determine if the Seal Point is registered, set the Seal Point setting to the lowest possible setting. Then press the **Manual Cycle** button or press the foot switch. The bag should move so that the perforation is approximately 1/8" from the center of the Heater Bar. If the bag perforation is not approximately 1/8" from the perforation, perform the following procedure carefully. If these steps are performed out of order, the bagger will not function properly.

Follow these steps to set up the perforation:

1. Press the **Find Perf** button. The Bagger will advance until the Perforation Sensor finds the perforation, and then the bag will stop.
2. Hold the **JOG+** button until the perforation moves down to the middle of the PTFE sheet area at the heater bar.

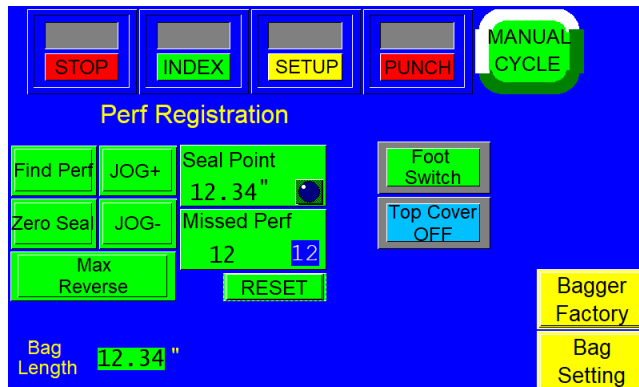

Figure 3- 21

3. Release the **JOG+** button.
4. Push the **Zero Seal** button once.
5. Hold the **JOG-** button until the perforation moves up to just in front of the nip rollers.
6. Push the **Max Reverse** button once.

Note: If these steps are performed incorrectly, repeat from Step 1.

When complete, test the **Seal Point** setting by entering 0.1" and pressing the **Manual Cycle** button. The bag should feed so that the perforation is approximately 1/8" from the center of the heater bar.

Since the procedure set the maximum reverse value as well, enter 6" in the **Max Reverse** setting. If equipped with a standard frame bagger, this setting will be approximately 1.8" when the **Seal Point** setting is 0.1". On a Drop Frame machine, the maximum setting will be approximately 2.7" when the **Seal Point** setting is 0.1". Press the **Manual Cycle** button and ensure that the bag does not reverse too far, to drop inside the machine. After successfully performing the above steps, the **Perf Registration** screen is ready for bag indexing.

Missed Perf: The maximum number of perforations the Sensor can miss before operation stops and an error message is displayed. To adjust this setting, press the **Missed Perf** button, enter the desired value on the numeric keypad and press the **ENT** button.

3.22 Warning and Message Screens

The Roll-a-Print touch screen program features many informational screens that are displayed automatically to alert the operator of situations on the machine. Some messages serve as functional messages that describe the status of equipment or errors, and some provide instructions for operators to follow to bring the bagger back online.

To reset a message screen, clear the condition first (if required) and then press **Return**. See Figure 3- 22 through Figure 3- 25 for examples of these messages.

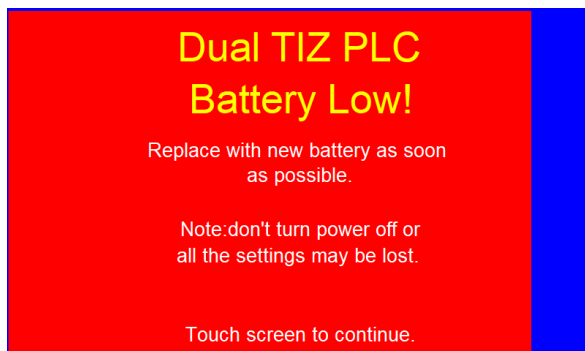

Figure 3- 22

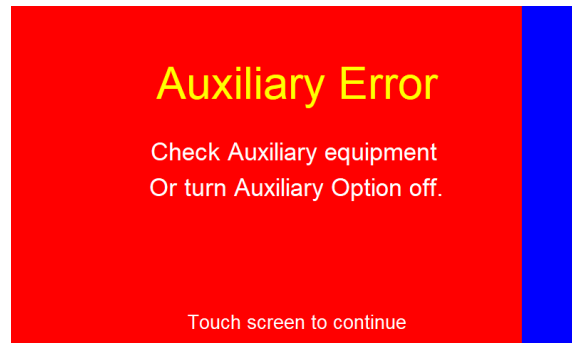

Figure 3- 23

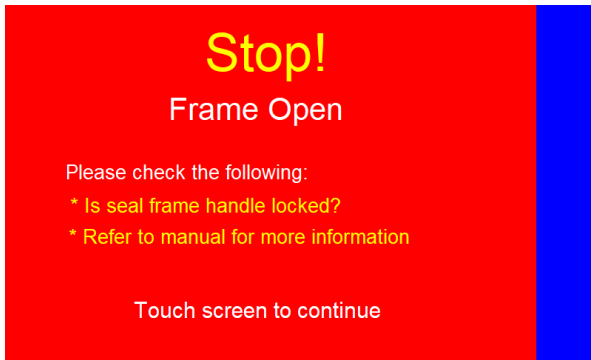

Figure 3- 24



Figure 3- 25

Chapter 4: Adjustments, Maintenance and Troubleshooting

Pinch Roller Alignment / Film Tracking

Roller Web Guides

Print Position (Left / Right Adjustment)

PLC IO Listing

Preventative Maintenance

4.1 Pinch Roller Alignment / Film Tracking

If bags or film are not feeding properly (straight) through the Roll-a-Print, then the pinch rollers may not be aligned. Film weaving may be caused by several factors, including poor tension, roller misalignment or improper threading.

To check the pinch rollers, position a light source inside the machine (near the print head), and from the front of the machine, slowly lower the frame by lowering the handle located on the right front of the RAP. As soon as the rollers are not touching one another, you can see a gap. With the gap at 1/32" or less, see if light is emitted consistently from the gap. Then raise the frame to determine if the rubber roller touches the steel roller at the same time, entirely across the rollers.

If the right side or left side of the rubber roller touches first, then the roller requires alignment. To adjust the rollers, first turn the power off and unplug the machine from the power source. The adjustment block assemblies are located on the front lower corners of the side plates, on each side.

On both the left panel and right panel, loosen the two locking bolts on the upper block of the compression tension assembly. Loosen the nut on the adjustment screw. With the inner frame locked in the UP position, lower the lower roller by turning the adjustment screws counter-clockwise until the lower roller is parallel to the upper roller and leaving 1/16" gap between the rollers. Turn the adjustment screw clockwise alternatively, keeping the lower roller parallel with the upper roller until the rollers come in contact across the width of the rollers. Slightly lower the inner frame and raise again to ensure that when raised again, the rollers touch simultaneously. Then "snug" the upper block bolts and recheck the alignment.

With the rollers slightly touching and parallel, turn each adjustment screw approximately ½ turn clockwise. Then test the compression by putting film between the rollers. Pull the film through the rollers while holding the rubber roller still. If the film pulls out easily, turn the compression adjustment screws 1/2 turn clockwise. Continue this adjustment until the film is slightly difficult to pull out of the rollers.

CAUTION: Over-tightening of the compression adjustment screws may cause damage to the upper (rubber) roller or the motor.

When you are satisfied with the compression, slightly lower the inner frame and slowly raise it until it almost touches the upper roller. If the gap is consistent across the width of the rollers and it appears parallel, lock the inner frame upward and re-tighten the two locking bolts on the upper block of the compression tension assembly. Then re-tighten the nut on the adjustment screws. Replace the covers, plug the cord into the power outlet and turn the main power on.

4.2 Roller Web Guides

Two plastic spring web guides, located immediately prior to and behind the print head assembly, are used for fine adjustment of tracking. Once the web is tracking within +/- 1/8" left to right, the web guides can be used to further assist tracking. Hold the upper roller in place while turning and sliding the aluminum guides close to the bags without touching the bags.

NOTE: If the bags are not tracking properly prior to moving the web guides to the film, the guides could actually cause the bag web to turn or fold over. If this occurs, slide the guides further away from the web and make adjustments to correct tracking.

4.3 Print Position (Left / Right Adjustment)

The Print Head can be moved left to right to adjust for print location. A locking mechanism can be attached to secure the Print Head into position.

4.4 PLC IO Listing

The Main PLC and Expansion PLC IO Listings are provided to assist in troubleshooting the Roll-a-Print.

MAIN PLC				
	INPUT	DESCRIPTION	OUTPUT	DESCRIPTION
	X0	Reserved	Y0	Stepper Pulse CW
	X1	Bag Out Sensor	Y1	Stepper Pulse CCW
	X2	Spare	Y2	Ribbon Drive
	X3	Perf Sensor	Y3	Spare
	X4	Spare	Y4	Spare
	X5	Black Mark Sensor	Y5	Spare
	X6	Spare	Y6	Spare
	X7	Door Safety Switch	Y7	Spare
	X8	Foot Switch	Y8	Reprint
	X9	Spare	Y9	Start Print
	XA	Frame Open Sensor	YA	Printer Pause
	XB	Label Downloaded	YB	Aux Ready
	XC	Printer Error	YC	Spare
	XD	End Print	YD	HV Trigger
	XE	Out of Ribbon	YE	Aux Out
	XF	Aux In	YF	Print Head Solenoid
EXPANSION PLC				
	X20	Spare	Y20	Spare
	X21	Spare	Y21	Spare
	X22	Spare	Y22	Spare
	X23	Spare	Y23	Spare
	X24	Spare	Y24	Spare
	X25	Spare	Y25	Spare
	X26	Spare	Y26	Spare
	X27	Spare	Y27	Spare
	X28-X2F	Spare	Y28F	Spare

4.5 Preventative Maintenance

The following maintenance items should be performed by the operator or maintenance personnel to prolong the life of the equipment. Failure to perform these tasks may result in premature wear, personal injury, or equipment damage.

ITEM	DESCRIPTION	FREQ.
Print head	Clean with a soft white cotton cloth each ribbon roll change	Each roll
Air pressure	Check air pressure to ensure 40 PSI	Daily
Printer rollers	Clean with a soft white cotton cloth until no residue is seen on the cloth	Daily
Pinch rollers	Clean with alcohol	Daily
Aluminum rollers	Clean with alcohol	Weekly
Perforation sensor	Clean with alcohol, inspect for wear	Weekly
Cylinders	Remove air and push in manually to ensure free movement with no binding	Weekly
Springs	Inspect for cracks in springs, ensure free movement	Monthly
Wiring	Ensure no loose contacts or worn shielding	Monthly
Fasteners	Tighten mounting bolts and fasteners	Monthly

Chapter 5: Parts and Drawings

Roll-A-Print 1400 System Layout

Stand Assembly

Dancer Assembly RAP1400

Dancer Assembly

Driven Wind-Up Unit

Main Body Assembly

Air Knife Assembly

IOP Assembly

Electronics Assembly

Zebra Roll-A-Print Assembly

Four Inch Printer Sub-Assembly

Bag Out Detector Assembly

Electronics Assembly (8" Print Head Model)

Electronics Assembly Detail

Eight Inch Printer Assembly

Roll-A-Print 2800 System Layout

Ti-1000Z Inline Thermal Printer

Mounting Assembly

Nip Roll Assembly

Printer Register

Notes

5.1 Roll-A-Print 1400 System Layout

T-ROLL1400

ITEM NO	QTY	PART NO.	DESCRIPTION	PAGE
1	1	TA-T6-60050	STAND ASSEMBLY RAP1400	38
2	1	TA-T6-600051	DANCER ASSEMBLY RAP 1400	39
3	1	TO-T1-WINDUP	DRIVEN WIND-UP UNIT	42
4	1	TA-T6-60000	MAIN BODY ASSEMBLY, RAP 1400	44
5	1	TA-T2Z-1000	ELECTRONICS ASSEMBLY RAP 1400	49
6	1	TA-T2Z-1000RAP	FOUR INCH PRINTER	54
7	1	TA-T6-60052	IOP ASSEMBLY, RAP-1400	48

NOTE: For the 8" Print Head Model (T-Roll 1400-08Z) the Electronics Assembly changes to TA-T2Z1000-08Z (p.45) and the Printer Assembly changes to TA-T2Z8000-08Z (p.48).

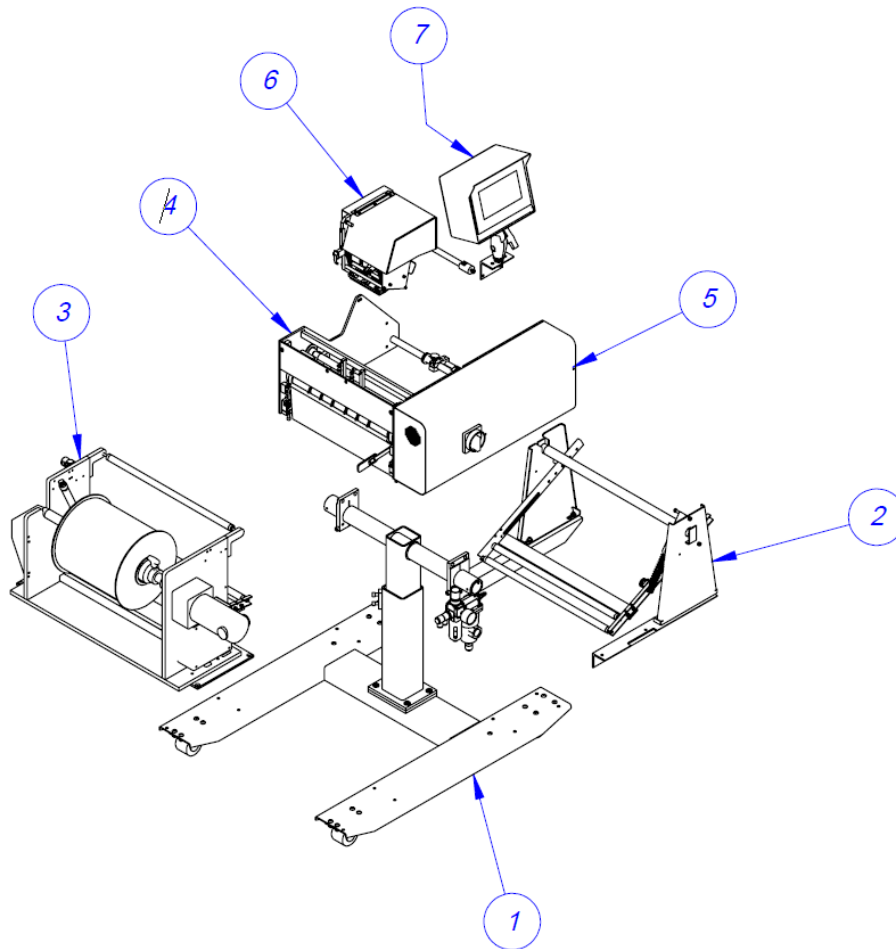

5.2 Stand Assembly

TA-T6-60050

ITEM NO.	QTY	PART NO.	DESCRIPTION
1	1	TP-T1MA00051RAP	LOWER BASE WELDMENT
2	2	TP-110763	CASTER, RIGID
3	2	TP-110756	CASTER, SWIVEL
4	1	TP-T1MA00051-1	LOWER COLUMN
5	1	TP-T1MA00087	CROSS PIPE
6	1	TP-T1MC00019-2	BASE CLAMP
7	1	TP-T1MC00019-1	BASE CLAMP
8	1	TP-T1MC00019-3	DRYER/REG BRACKET
9	1	TP-406260-1	FILTER / DRYER/ REGULATOR ASSEMBLY
10	1	TP-401222	HEX NIPPLE
11	1	TP-401267	DOUBLE ELBOW

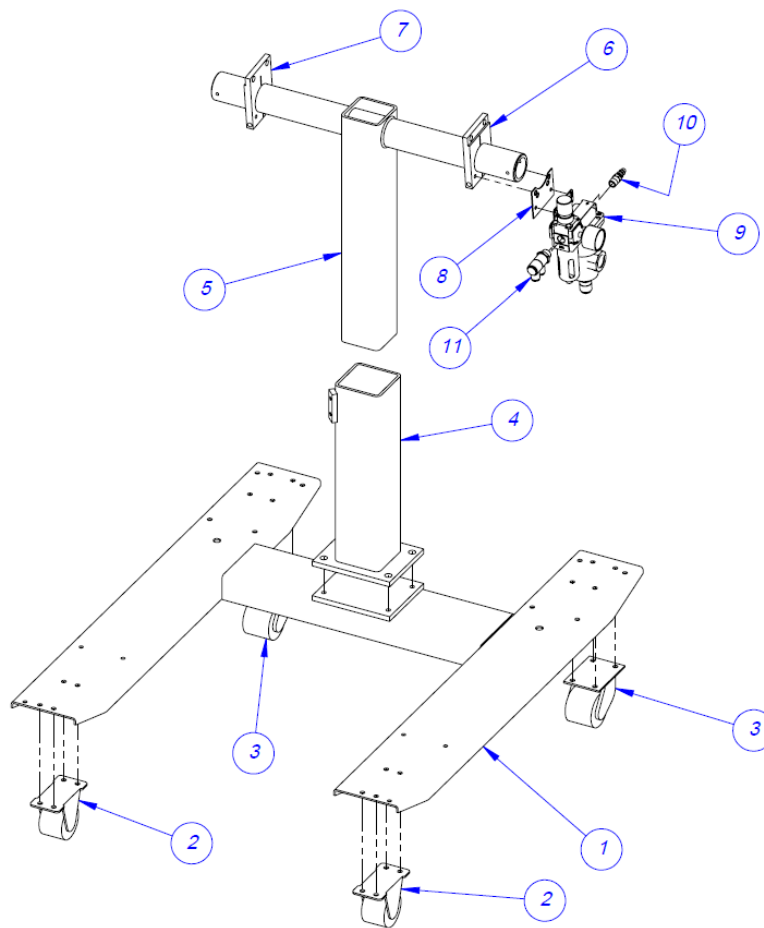

5.3 Dancer Assembly RAP1400

TA-T6-60051

ITEM NO.	QTY.	PART NO.	DESCRIPTION
1	1	TA-T1-10220	DANCER ASSEMBLY
2	1	TP-T6RW0031	DANCER EXTENSION (RIGHT)
3	1	TP-T6RW0032	DANCER EXTENSION (LEFT)

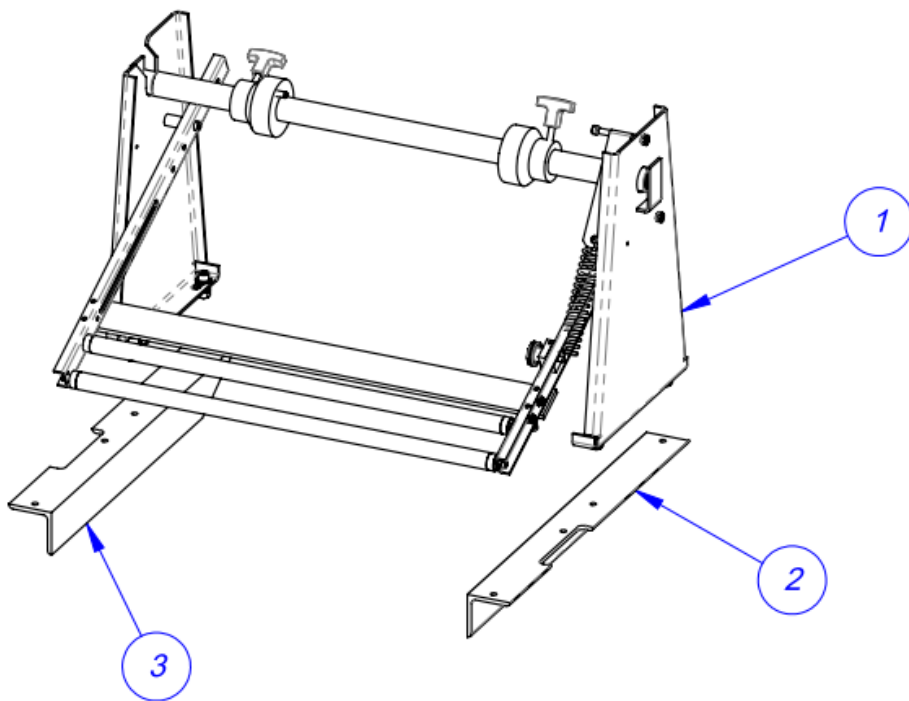

5.4 Dancer Assembly

TA-T1-10220

ITEM NO.	QTY	PART NO.	DESCRIPTION
1	1	TP-T1MA00069-1	DANCER SIDE PLATE
2	1	TP-T1MA00069-2	DANCER SIDE PLATE
3	1	TA-T1-10011	DANCER GUIDE SUB-ASSEMBLY
4	1	TP-T1MA00073	BAG ROLL SHAFT
5	2	TP-504132	CAM FOLLOWER
6	1	TP-T1MA00115	BELT TENSION STRAP & SPRING
7	2	TP-104148	SPACER
8	3	TP-101141	LOCKNUT, HEX #10-24
9	2	TP-T1MA00049	FILM TENSION HUB
10	2	TP-103307	SHOULDER SCREW, 1/4" X 1-1/4" L
11	2	TP-106106	SPRING PIN
12	2	TP-109212-1	"T" KNOB
13	1	TP-103583	SHOULDER SCREW, 1/4" X 1-1/2" L

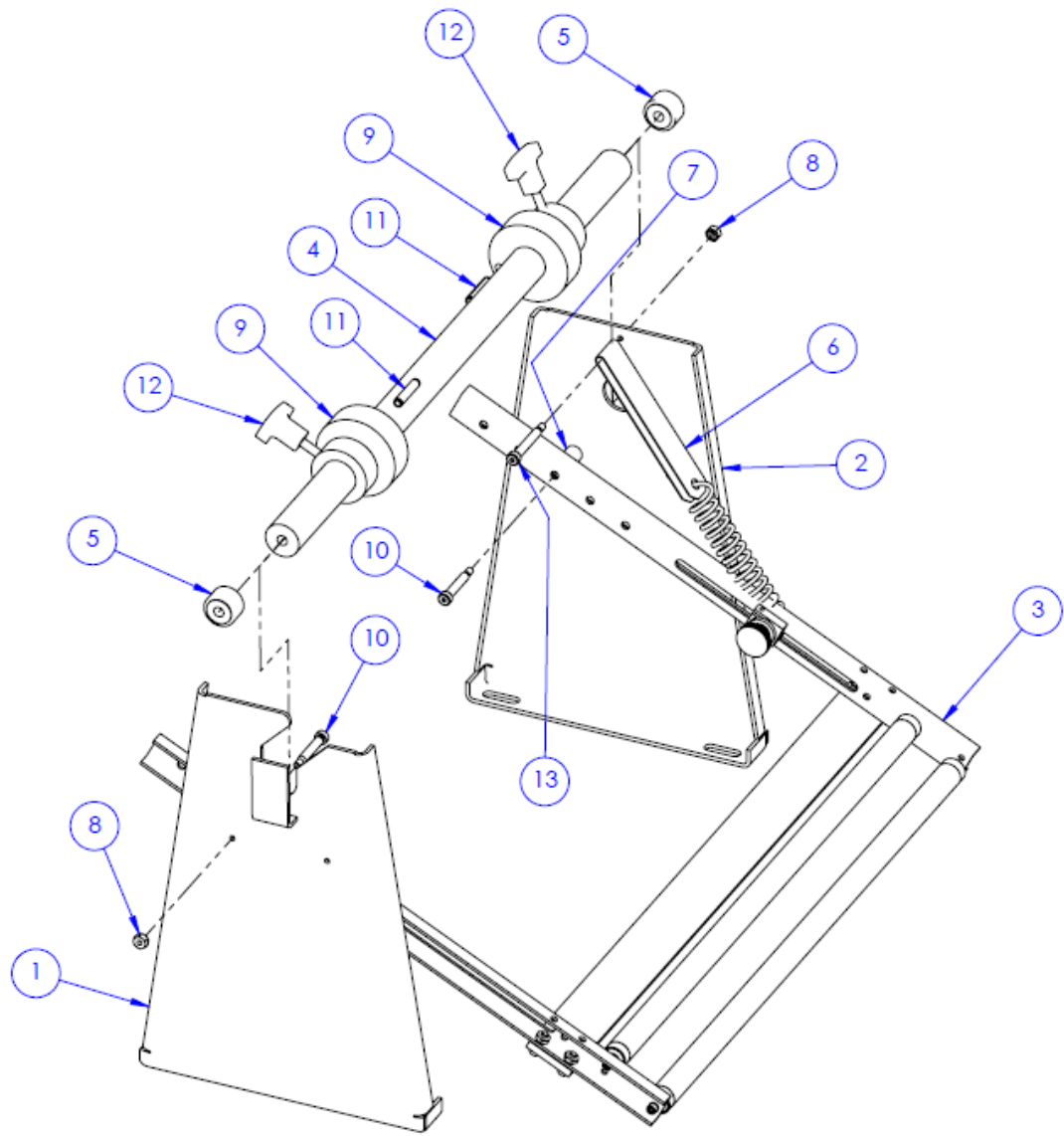

5.5 Driven Wind-Up Unit

TO-T1-WINDUP

ITEM NO.	QTY.	PART NO.	DESCRIPTION
1	1	TP-T6RW0016	BASE
2	1	TP-T6RW0012-1	SIDE PLATE - LEFT
3	1	TP-T6RW0012-2	SIDE PLATE - RIGHT
4	1	TP-406259	MINI-REG ASSEMBLY
5	1	TP-T6RW0017	ROLLER EXTENSION
6	1	TP-T6RW0017	ROLLER EXTENSION
7	1	ASSEMBLY	STANDARD ROLLER
8	2	TP-108099	COMPRESSION SPRING
9	1	TP-T6RW0014	COUPLING
10	1	TA-T6-QC10	QUICK CHANGE ROLL ASSEMBLY
11	1	TA-T6-RW300	DANCER ASSEMBLY
12	1	TP-T6RW0022	WINDUP SHAFT
13	1	TP-T6RW0020	CYLINDER SHAFT MOUNTING BLOCK
14	1	TP-501115	MOTOR
15	1	TP-T6RW0025	BOTTOM COVER
16	1	TP-T6RW0026	TOP COVER
17	1	TP-T6RW0024	RACEWAY
18	1	TP-217006	DRIVE SPEED CONTROL
19	1	TP-T6RW0029	SPEED CONTROL BRACKET
20	1	TP-215022	LIMIT SWITCH, SNAP ACTION
21	1	TP-T6RW0030	LIMIT SWITCH PULLEY
22	1	TP-503124	TOOTH PULLY
23	1	TP-212106	STRAIN RELIEF
24	1	PART OF 217006	POTENTIOMETER
25	1	TP-T6A1058	REWIND MOUNT, RIGHT
26	1	TP-T6A1059	REWIND MOUNT, LEFT
27	1	TP-503107	BELT
28	1	TP-T6RW0013	DANCER BRACKET
29	1	TP-403248	CYLINDER
30	1	TP-404252	ROD CLEVIS
31	1	TP-107177	BUSHING

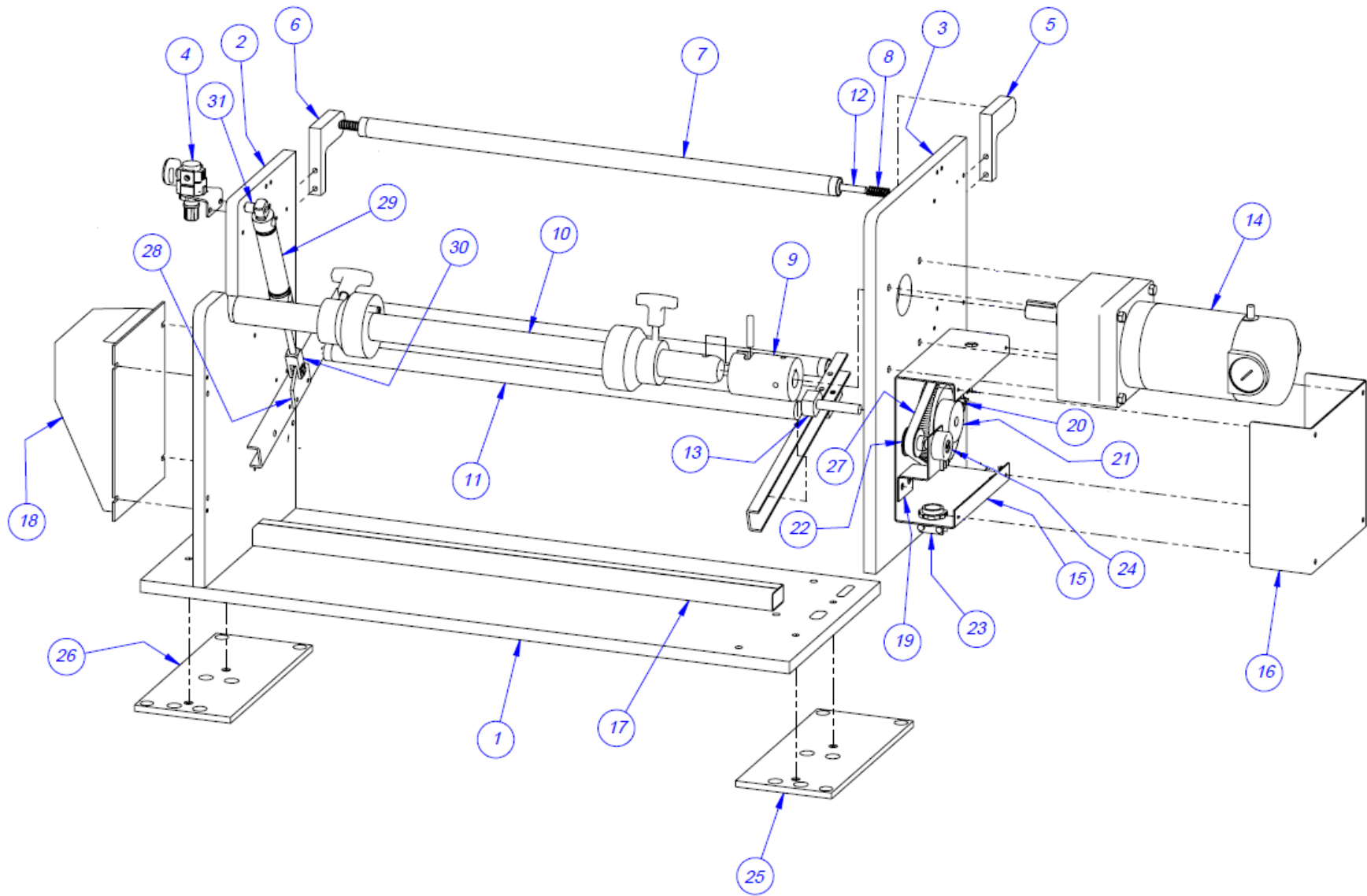

5.6 Main Body Assembly

TA-T6-60000

ITEM NO.	QTY	PART NO.	DESCRIPTION
1	1	TP-T6A1012	SIDE PLATE (LEFT)
2	1	TP-T6A1013	SIDE FRAME (RIGHT)
3	2	TP-T1MC00044	FACE PLATE BLOCK
4	1	TP-T1MC00042NB	FACE PLATE
5	2	TP-T1MC00079	CYLINDER PIVOT SHAFT
6	2	TP-T100054	COVER SUPPORT CLAMP
7	2	TP-T1MC00018-S14	ROLLER MOUNT
8	1	TP-T1MC00118-1	WEB ROLLER BRACKET
9	1	TP-T100119	FILM WEB ROLLER
10	1	TP-T100120	FILM WEB ROLLER SHAFT
11	1	TP-T1MC00118-2	WEB ROLLER BRACKET
12	2	TP-107177	BUSHING
13	2	TP-T1MC00125S14	SENSOR MOUNTING BAR
14	1	TP-T1MC00083	H.V. SENSOR INSULATOR
15	1	TP-BP-1013-S14	MOUNTING BAR
16	1	TP-T100020NB	FINGER PLATE
17	2	TP-T1MC00124-3	H.V. SENSOR MOUNT
18	2	TP-T1MC00124-1	H.V. TANG
19	2	TP-106214	COTTER PIN
20	2	TP-108118	TORSION SPRING
21	2	TP-T6A1006	NIP ROLL MOUNT
22	1	TP-T1MB00013	ALUMINUM ROLLER SHAFT
23	1	TP-T1MB00012	ROLLER
24	2	TP-107227	BUSHING, THRUST NYLON
25	2	TP-504107	BEARING, .500 BORE
26	2	TP-T6A1005	LINK ADJUSTER
27	2	TP-T6A1001	LINK
28	2	TP-T6A1008	CLAMP LINK
29	2	TP-211374	MAGNET, ROUND
30	1	TP-T6A1033	HANDLE
31	1	TP-T6A1015	ROLLER FINGER
32	1	TP-T6A1025	FRONT COVER
33	1	TP-T6A1056	HANDLE

34	1	TP-106134	GROOVED DOWEL PIN
35	2	TP-T6A1004	LINK STOP
36	1	TP-215200	MAGNETIC SWITCH
37	1	TP-T1MC00161	DRIVEN PULLEY
38	1	TP-501165	T-375 MOTOR
39	1	TP-T41027	MOTOR PULLEY
40	1	TP-T100091	BELT TENSIONER
41	1	TP-504132	CAM FOLLOWER
42	1	TP-107342	BEARING, THRUST
43	2	TP-504114	BEARING, 1/2" BORE
44	1	TP-T6A1050	PRINT ROLL
45	2	TP-T6A1002	ADJUSTER BLOCK
46	1	TP-BO-185	BAG-OUT SENSOR CLAMP
47	1	TP-BO-175	BAG-OUT DETECTOR BLOCK
48	1	TP-109212	KNOB
49	1	TP-215005	SWITCH
50	1	TP-215004	SWITCH KNOB
51	2	TP-111010	SPRING CLOSURE COLLAR
52	1	TP-T6A1027	SIDE COVER
53	1	TP-T2Z2005	LATCH BAR
54	1	TP-T1MC00017RAO	MODIFICATION DRAWING
55	2	TP-504113	ROLLER BEARING .750 I.D.
56	1	TP-T2Z2012	COVER PANEL STAND-OFF
57	1	TP-T6A1010	SWITCH MOUNTING BRACKET

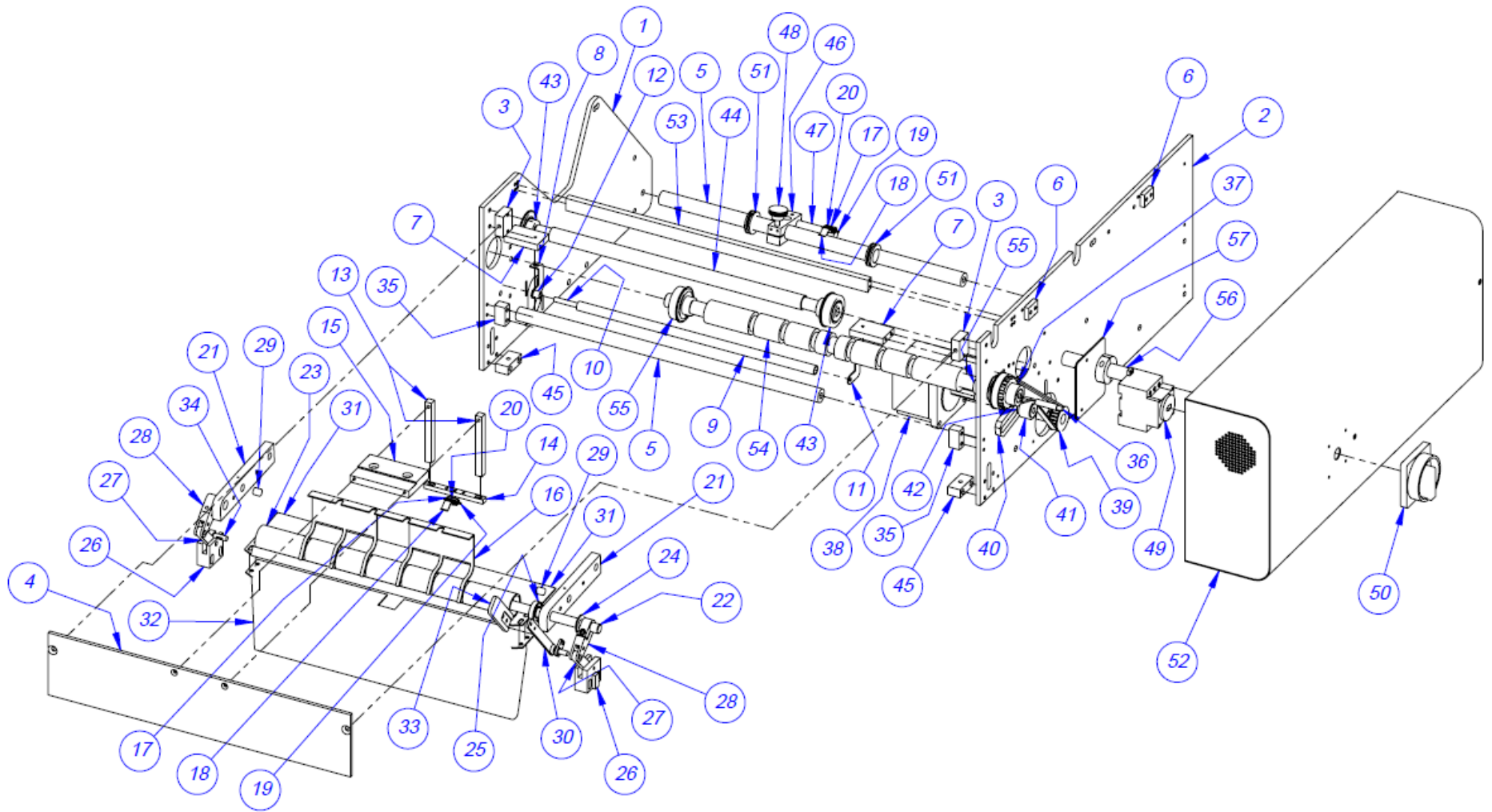

5.7 Air Knife Assembly

TA-T1-10001-S14RAP

ITEM NO.	QTY	PART NO.	DESCRIPTION
1	1	TP-BP-1013-S14	MOUNTING BAR
2	2	TP-T1MC00125S14	SENSOR MOUNTING BAR
3	1	TP-T1MC0083	H.V. SENSOR INSULATOR
4	1	TP-T100020NB	FINGER PLATE
5	1	TA-T100124-3	H.V. SENSOR MOUNT
6	1	TA-T100124-1	H.V. SENSOR ASSEMBLY
7	1	TP-108118	TORSION SPRING
8	1	TP-106214	COTTER PIN

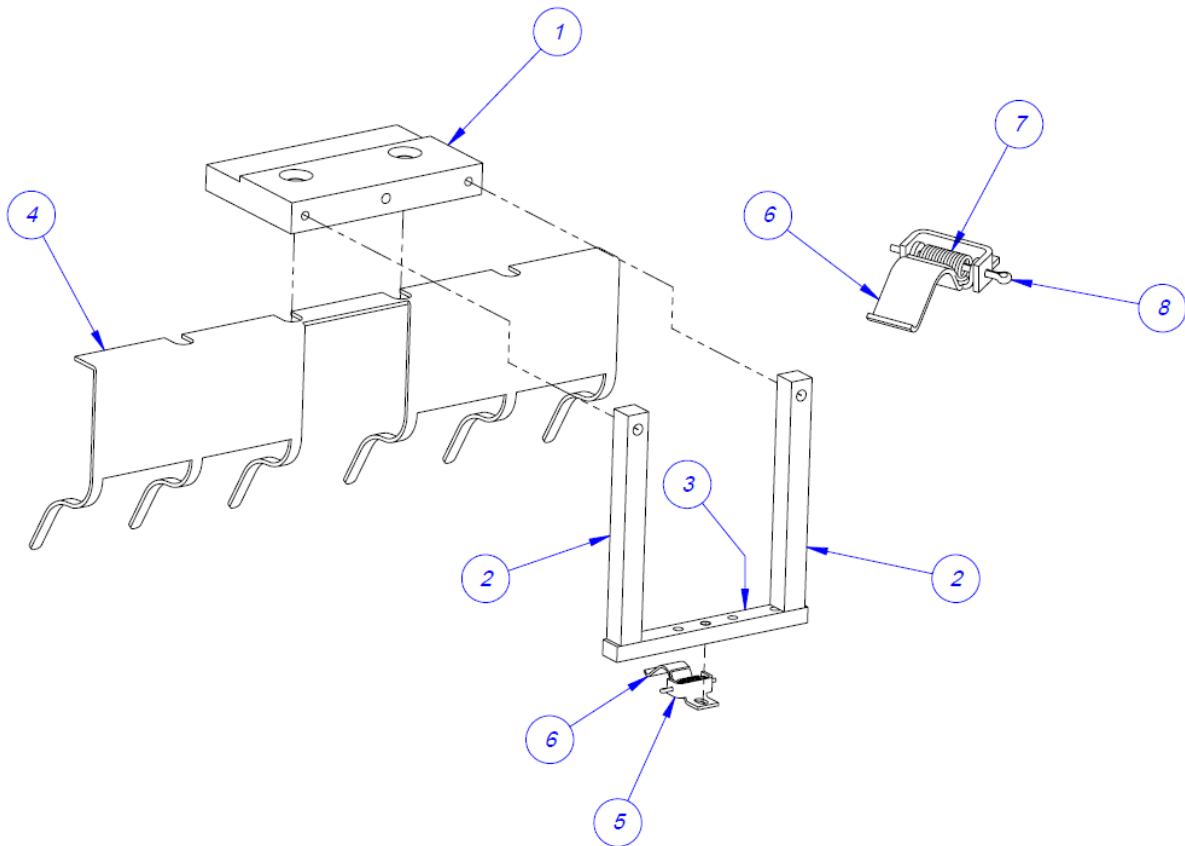

5.8 IOP Assembly

TA-T6-60052

ITEM NO.	QTY	PART NO.	DESCRIPTION
1	1	TA-T10240-IOP	SEVEN-INCH TOUCH SCREEN
2	1	TP-T6MD00109	TOUCH SCREEN MOUNT
3	1	TP-102146	WASHER, 1/2" FLAT
4	1	TP-102159	WASHER, 1/2" LOCK
5	1	TP-101117	NUT, 1/2-13 HEX

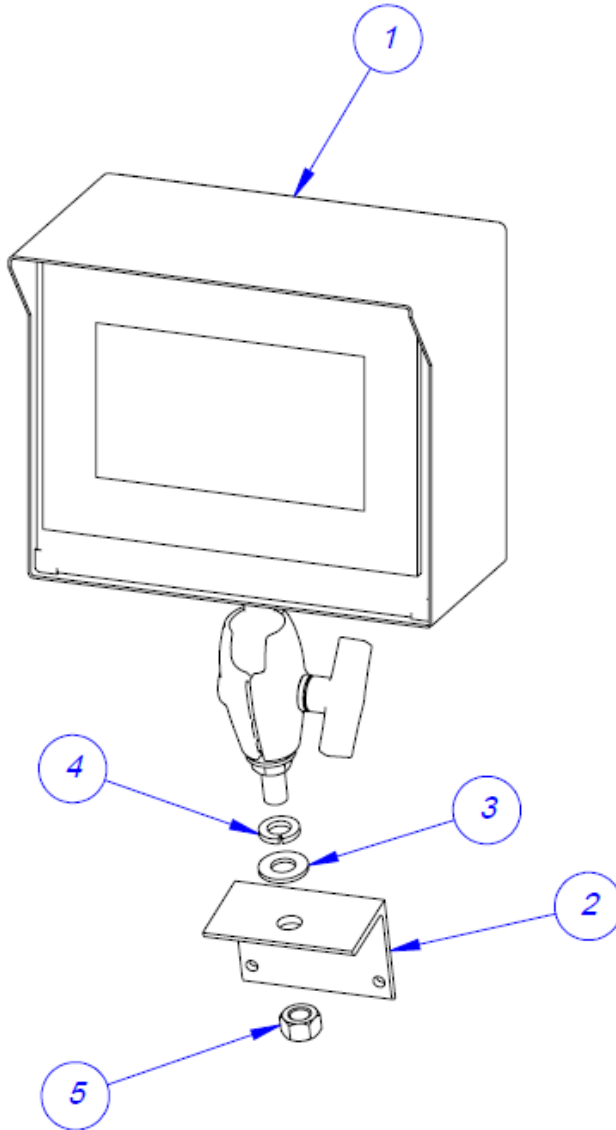

5.9 Electronics Assembly

TA-T2Z-1000RAP

ITEM NO.	QTY	PART NO.	DESCRIPTION
1	1	TA-T2Z-1000	ELECTRONICS ASSEMBLY
2	1	TP-T1MC00021-RAP	TRANSFORMER MOUNTING PLATE
3	1	TP-211386	HIGH VOLTAGE TRANSFORMER
4	1	TP-211386-1	HEAT SHIELD
5	1	TP-T1ME00301	HIGH VOLTAGE BOARD
6	1	TP-501169-1	5-PHASE MOTOR DRIVE
7	1	TP-T6A1009	DRIVE MOUNT

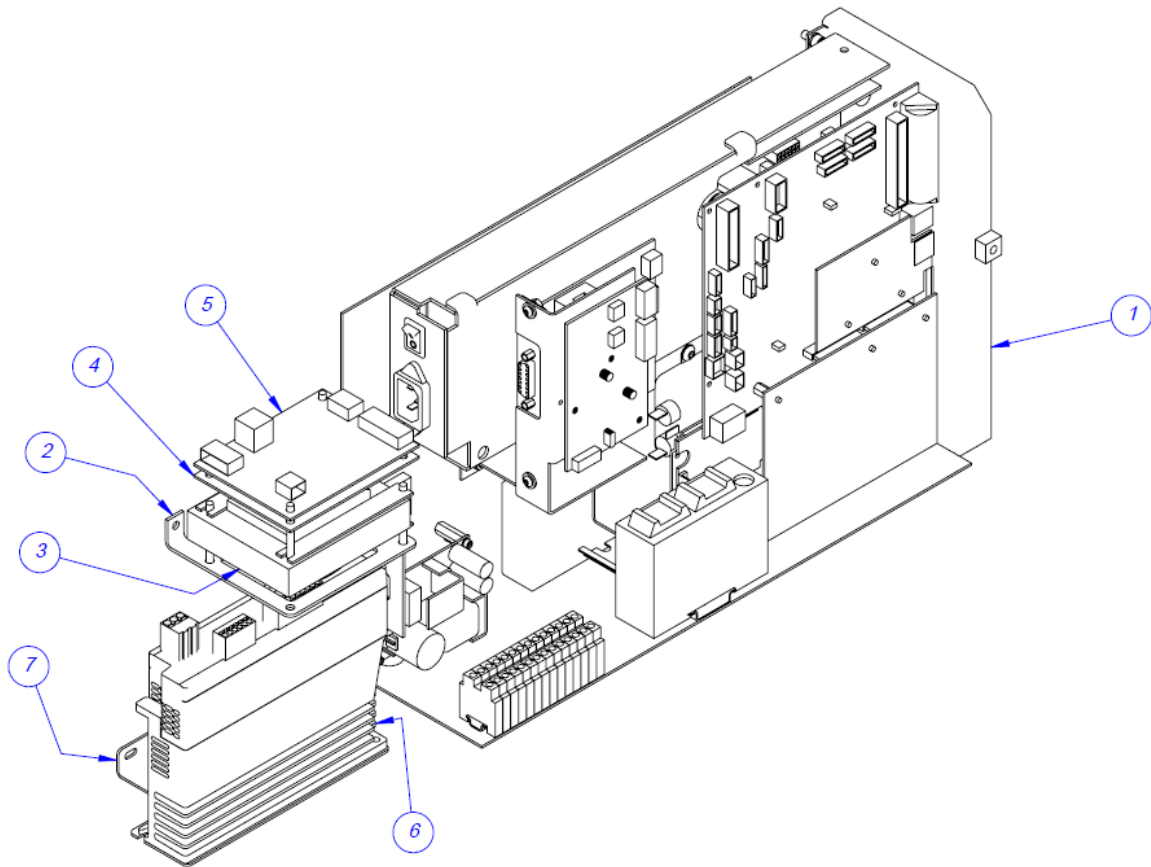

Printer Electronics Assembly (Continued)

TA-T2Z-1000

ITEM NO.	QTY.	PART NO.	DESCRIPTION
1	1	TP-T2Z1005	ELECTRONICS BASE
2	2	TP-212247	9-PIN D-SUB FEMALE
3	1	TP-215384	POWER SWITCH
4	1	TP-218020	DIN-3 RAIL
5	1	TP- 220511,214111,220513	PLC, BATTERY & COMM 2 CAS
6	1	TP-212246	9-PIN D-SUB MALE
7	1	TP-207216, TP-207224	FUSE HOLDER & FUSE
8	1	TP-212410	RECEPTACLE, SNAP-IN QC TABS
9	14	TP-208142	LARGE TERMINAL BLOCK
10	1	TP-218020	DIN RAIL
11	1	TP-212160	5-POS MINI DIN
12	1	TP-112240	POWER CORD STRAIN RELIEF
13	1	V-Z-P1053360-016	LOGIC BOARD
14	1	TP-213361	24VDC, 3AMP POWER SUPPLY
15	1	TP-205108	EMI FILTER, CORCOM
16	1	TP-501156	DC MOTOR DRIVE, DRIVEN PRINT ROLL
17	1	TP-T2Z1007	OVERLAY
18	1	TP-T2Z1004	APPLICATOR BOARD MOUNT
19	1	VP-Z-P1011156	XI4 24-28V APPLICATOR INTERFACE OPTION/MAINT KIT
20	1	VP-Z-57389M	APPLICATOR INTERFACE ASSEMBLY 24V
21	4	TP-214273	STAND-OFF, NYLON, 1/2", #4-40
22	6	TP-214327	SCREW JACK
23	1	TP-T2Z1018	POWER SUPPLY MOUNT
24	1	VP-Z-P1058301	ZEBRA POWER SUPPLY (REV A)

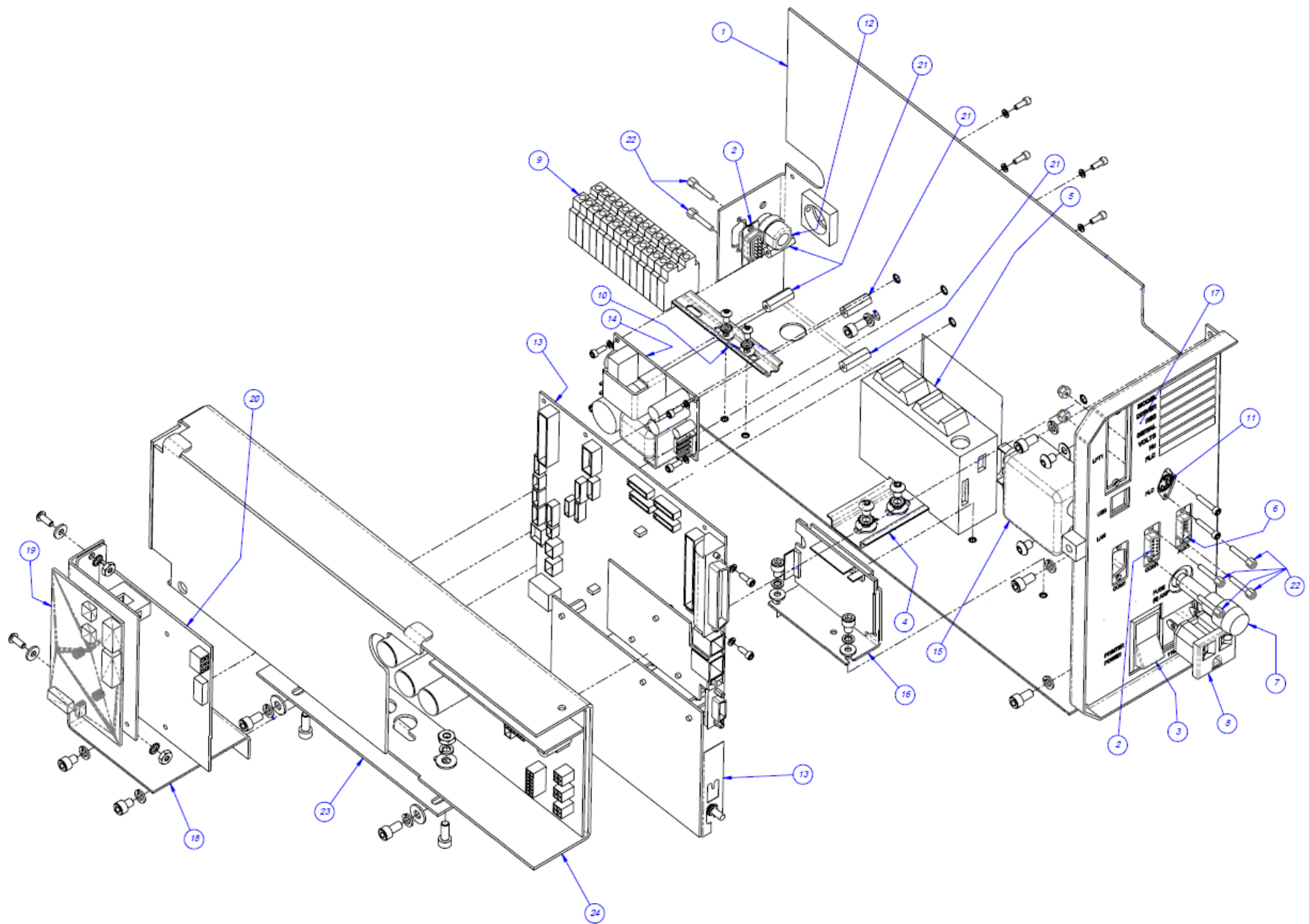

5.10 Zebra Roll-A-Print Assembly

TA-T15-8000RAP

ITEM NO.	QTY	PART NO.	DESCRIPTION
1	1	TA-T15-8000	ZEBRA PRINTER ASSEMBLY
2	1	TP-T2Z8101	HINGE ASSEMBLY
3	1	TP-T2Z8102	LEXAN PRINTER GUARD
4	1	TP-T2Z2010	STOP BAR
5	1	TP-T15M8105	BLADE DRAW LATCH
6	1	TP-T2Z2004	PIVOT SHAFT
7	2	TP-T14M1035	GUIDE ROD HOLDER
8	1	TP-T6A1057	COLLAR STOP
9	1	TP-103519	SCREW, 1/4-20 X 1/4" SET
10	3	TP-101103	NUT, #8-32 MACHINE
11	5	TP-102153	WASHER, #8 LOCK
12	3	TP-102133	WASHER, #8 FLAT
13	3	TP-103212	SCREW, BHCS 8-32 X 1/2" S.S.
14	2	TP-103310	SCREW, SHOULDER
15	2	TP-103117	SCREW, SHCS 8-32 X 3/4"
16	2	TP-103391	SCREW, FHCS 8-32 X 3/4"
17	2	TP-102101	WASHER, #4 INT. TOOTH LOCK WASHER
18	2	TP-103202	SCREW, BHCS 4-40 X 5/16"
19	2	TP-103606	SCREW, 10-32 CONE POINT SET

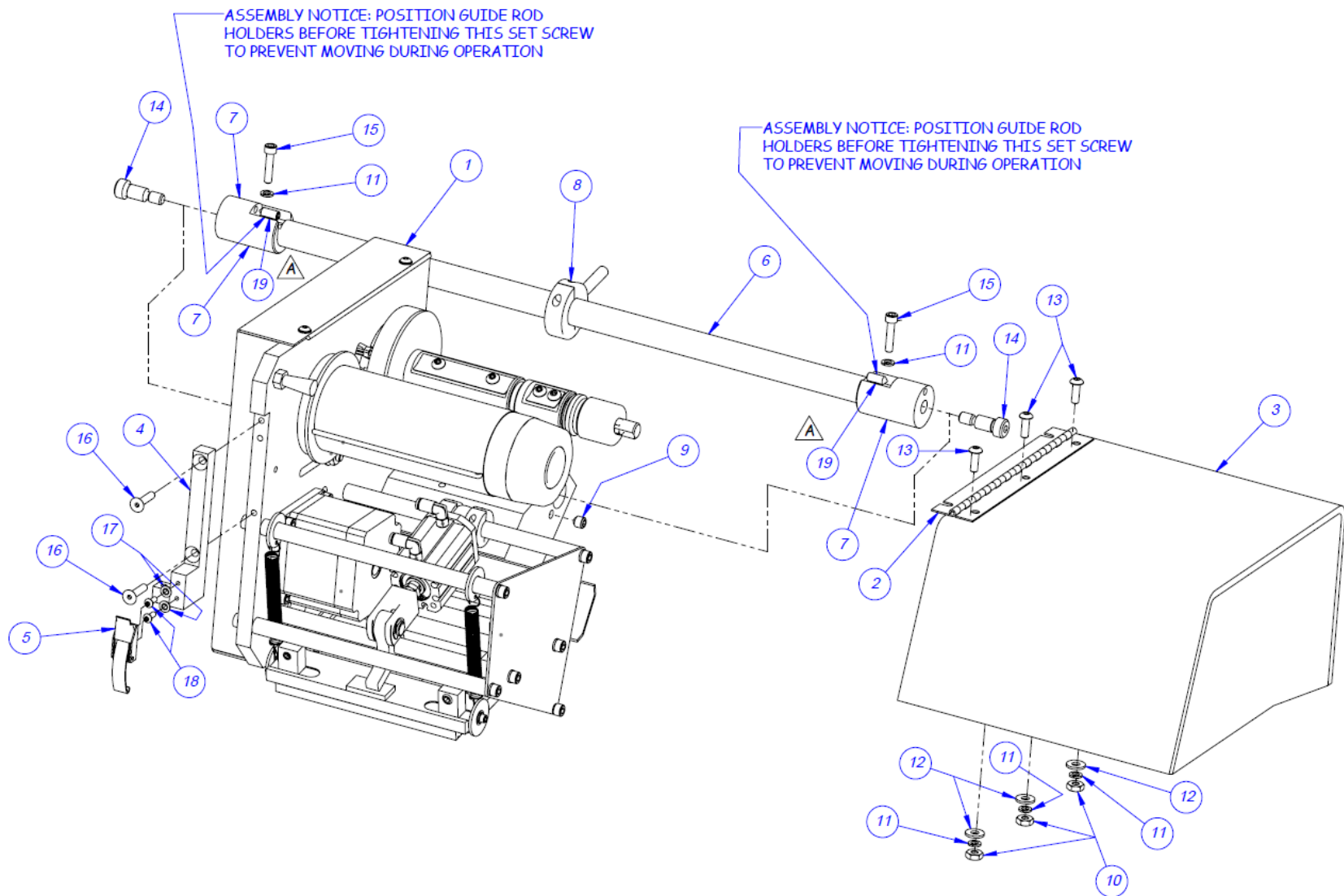

5.11 Four Inch Printer Sub-Assembly

TA-T15-8000

ITEM NO	QTY.	PART NO.	DESCRIPTION
1	1	TP-T15M8001	PRINTER SIDE PLATE
2	1	TP-T15M8002	MOUNTING PLATE PRINT HEAD
3	2	TP-T15M8003	ADJUSTMENT BLOCK
4	5	TP-T15M8004	SUPPORT ROD
5	1	TP-T15M8005	CAM-PRINT HEAD
6	1	TP-T15M8006	CYLINDER MOUNT
7	1	TP-T15M8007	BELT TENSIONER
8	1	TP-T15M8008	BELT GUARD
9	1	TP-T15M8010	LOCATING SPACER
10	1	TP-T15M8011	SENSOR BRACKET
11	2	TP-T15M8012	SPRING MOUNT
12	2	TP-T15M8013	ADJUSTMENT ROD
13	2	TP-T15M8014	ADJUSTMENT ROD BLOCK
14	1	TP-T15M8030	END PLATE
15	1	TP-T15M8031	ROLLER SHAFT
16	1	TP-T15M8032	SHAFT MOUNT
17	1	TP-T15M0036	PIVOT BLOCK
18	1	TP-T15M8038	WEAR SURFACE
19	1	TP-T15M8042	RIBBON TAKE-UP PULLEY
20	1	TP-T15M8043	LOCATING SPACER
21	1	TP-T15M8044	SUPPLY SPOOL SPACER
22	1	TA-Z-41150M	RIBBON TAKE-UP SPINDLE
23	2	TP-108133	SPRING
24	2	TP-108099	COMPRESSION SPRING,.040 GAUGE
25	2	TP-106304	10MM DOWEL PIN
26	2	TP-111107	COLLAR CLAMP
27	1	TP-402260	PNEUMATIC VALVE
28	1	TP-401265	AIR FITTING
29	2	TP-401294	1/8-INCH FITTING
30	1	TP-403140	AIR CYLINDER
31	2	TP-404263	MUFFLER
32	1	VP-Z-P1006058	xi4 RIBBON SUPPLY SPINDLE KIT
33	1	VP-Z-P1004230	PRINT HEAD
34	1	VP-Z-46198M	203 DPI Zebra Motor
35	2	TP-401294-1	MALE CONNECTOR, 1/8" TUBE
36	1	TP-404148	CLEVIS
37	1	TP-402175	BRACKET

38	1	TP-109225	FINGER KNOB
39	1	TP-504138	CAM FOLLOWER
40	1	TP-503113	BELT
41	1	TP-504175	CLUTCH BEARING
42	1	TP-107116	SLEEVE BUSHING
43	2	TP-102119	NYLON WASHER
44	1	TP-104112	NYLON SPACER
45	1	VP-Z-P1006134	ZEBRA RIBBON OUT SENSOR

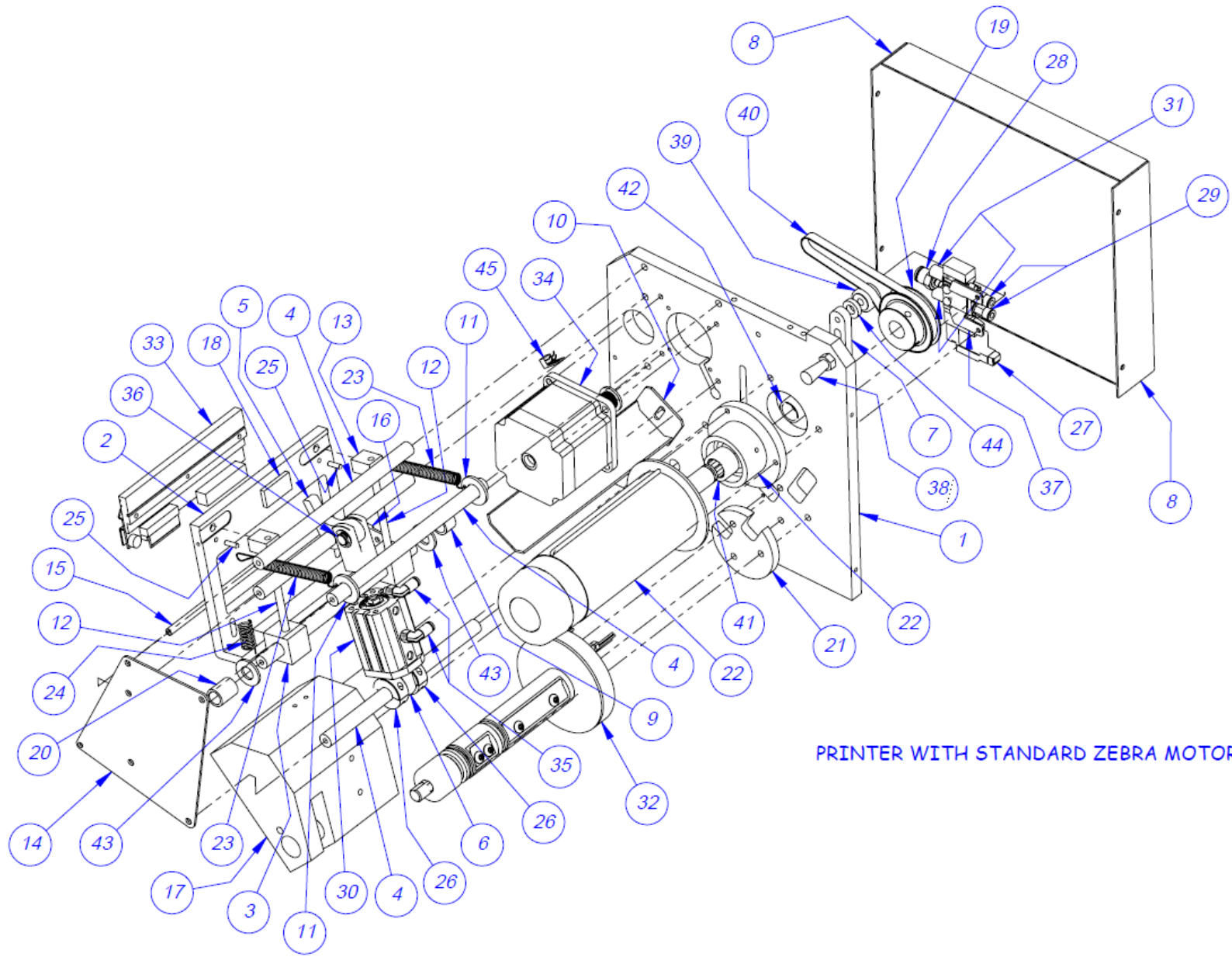

PRINTER WITH STANDARD ZEBRA MOTOR

5.12 Bag Out Detector Assembly

TA-T2Z-BO10

ITEM NO.	QTY	PART NO	DESCRIPTION
1	1	TP-T15M8040	BAG OUT SENSOR BRACKET
2	1	TP-216101	1" DIAMETER REFLECTOR, ADHESIVE BACK
3	1	TP-216155	DIFFUSE REFLECTIVE SENSOR

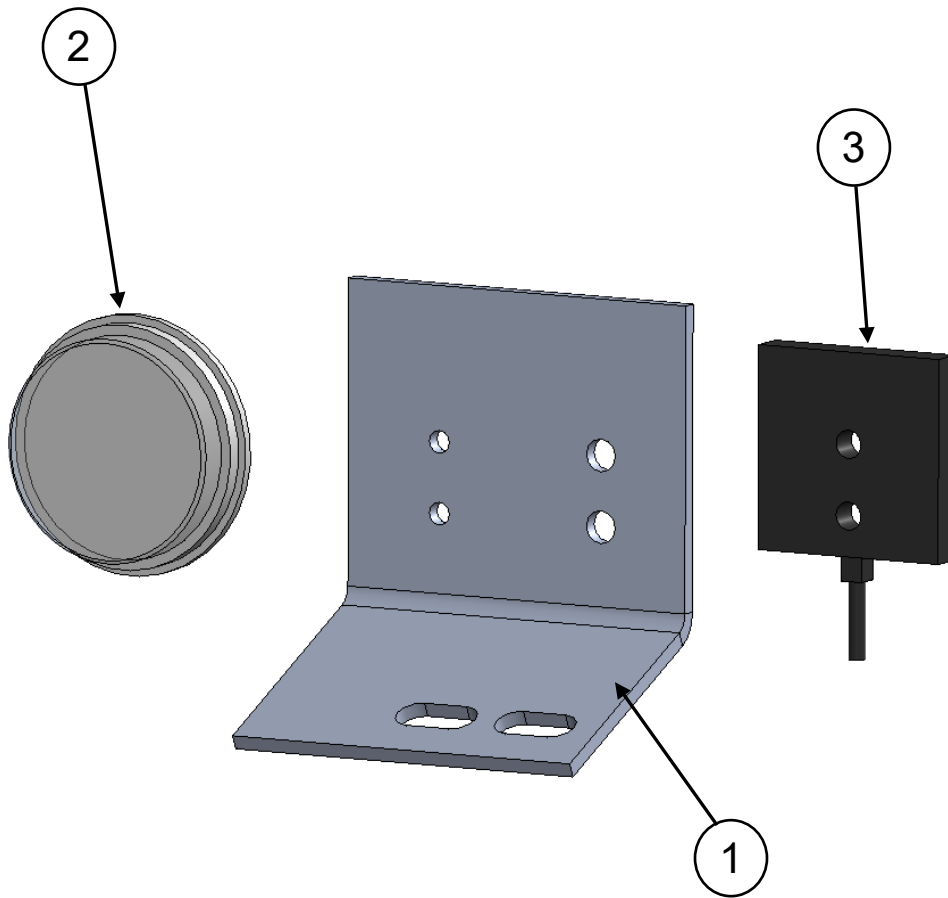

5.13 Electronics Assembly (8" Print Head Model)

TA-T2Z-1000-08Z

ITEM NO.	QTY.	PART NO.	DESCRIPTION
1	1	SEE DETAIL	ELECTRONICS ASSEMBLY
2	1	TP-T1MC00021-RAP	TRANSFORMER MOUNTING PLATE
3	1	TP-211386	HIGH VOLTAGE TRANSFORMER
4	1	TP-211386-1	HEAT SHIELD
5	1	TP-T1ME00301	HIGH VOLTAGE BOARD
6	1	TP-T6A1009	DRIVE MOUNT
7	1	TP-501169-1	5=PHASE DRIVER

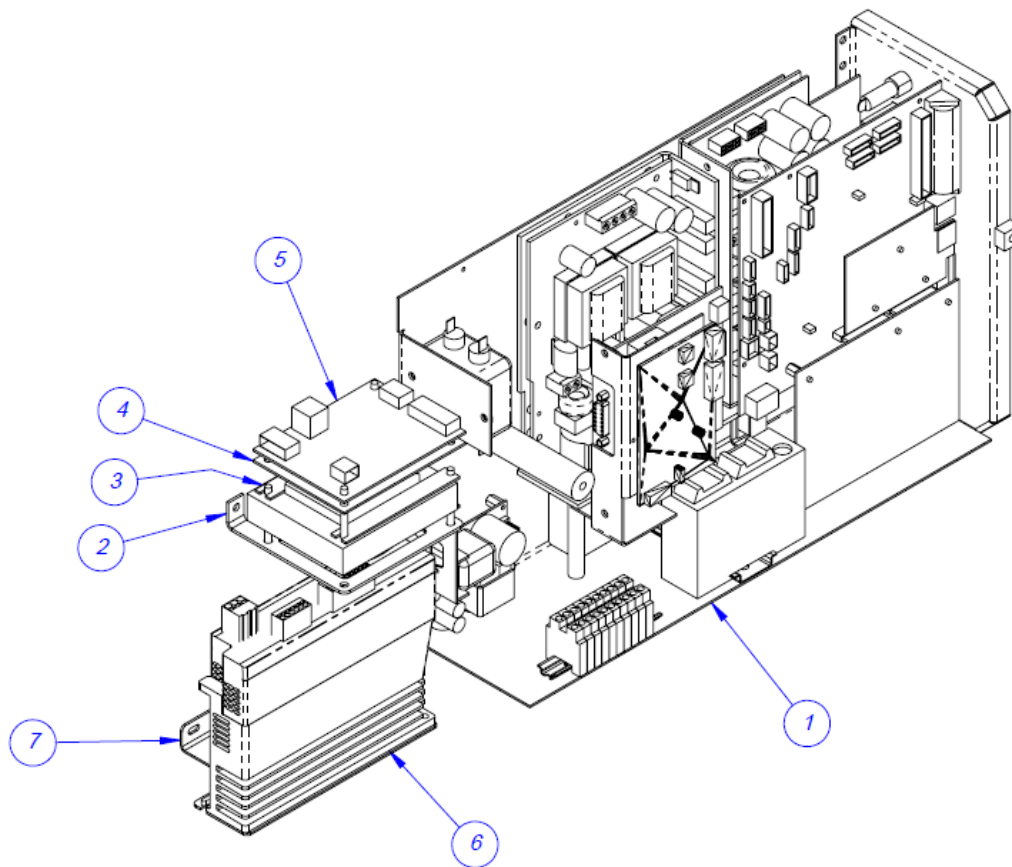

5.14 Electronics Assembly Detail

TA-T2Z-1000-08Z

ITEM NO.	QTY.	PART NO.	DESCRIPTION
1	1	TP-T2Z1005	ELECTRONICS BASE
2	1	TP-215384	POWER SWITCH
3	1	TP-207216	FUSE HOLDER
4	1	TP-212247	9-PIN D-SUB FEMALE
5	1	TP-212160	PLC CONNECTOR
6	1	VP-Z-P1053360-016	XI4 8MB LOGIC BOARD
7	1	TP-212246	9-PIN D-SUB MALE
8	1	TP-212410	AC OUTLET
9	1	TP-205108	EMI FILTER, CORCOM
10	1	TP-213361	24VDC, 3AMP POWER SUPPLY
11	1	TP-218020	DIN 3 RAIL
12	1	TP-208142, TP-218021	DIN RAIL & TERM BLOCK
13	1	(AC)VP-Z-P1007557, (DC)VP-Z-P1040670	AC/DC POWER SUPPLY
14	1	TP-501156	DC MOTOR DRIVE, DRIVEN PRINT ROLL
15	1	TP-T2Z2012	COVER PANEL STAND-OFF
16	1	TP-T2Z1004	APPLICATOR BOARD & MOUNT
17	1	TP-214268	STAND-OFF 3/8"

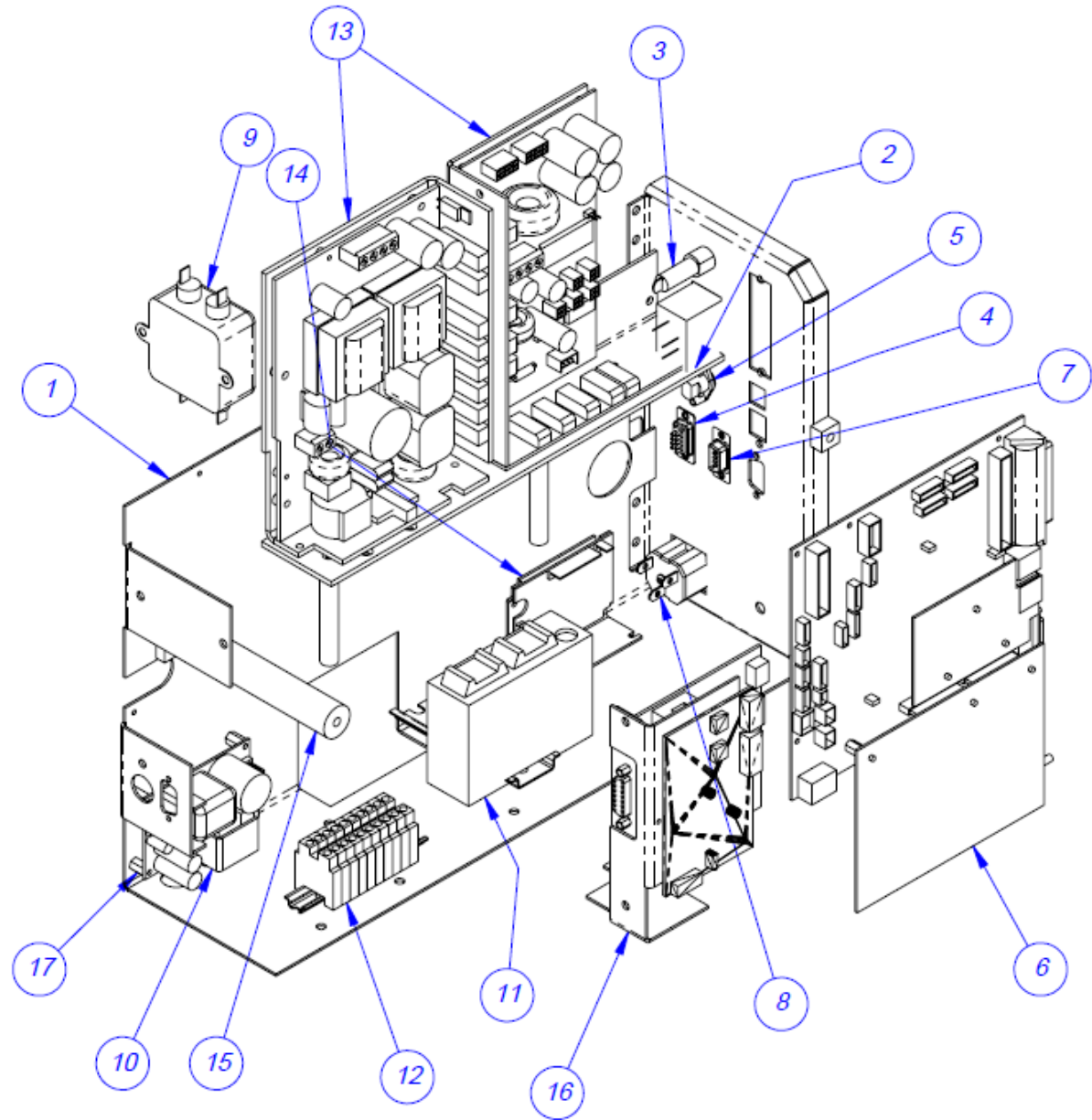

5.15 Eight Inch Printer Assembly

TA-T2Z-8000-08Z

ITEM NO.	QTY.	PART NO.	DESCRIPTION
1	1	TP-T15M8001RAP	PRINTER SIDE PLATE
2	1	TP-T15M8002RAP	MOUNTING PLATE PRINT HEAD
3	2	TP-T15M8003	ADJUSTMENT BLOCK
4	5	TP-T15M8004RAP	SUPPORT ROD
5	1	TP-T15M8005	CAM-PRINT HEAD
6	1	TP-T15M8006	CYLINDER MOUNT
7	1	TP-T15M8008RAP	BELT GUARD
8	1	TP-T15M8010	LOCATING SPACER
9	2	TP-15M8012	SPRING MOUNT
10	2	TP-15M8013	ADJUSTMENT ROD
11	2	TP-15M8014	ADJUSTMENT ROD BLOCK
12	1	TP-T15M8030RAP	END PLATE
13	1	TP-T15M8031RAP	ROLLER SHAFT
14	1	TP-T15M8032	SHAFT MOUNT
15	1	TP-T15M0036	PIVOT BLOCK
16	2	TP-111107	6435K33 COLLAR CLAMP
17	1	TP-402175	BRACKET
18	1	TP-402260	VALVE
19	2	TP-404263	MUFFLER
20	1	TP-401265	AIR FITTING
21	1	TP-403140	AIR CYLINDER
22	1	VP-Z-P1006062	X14 RIBBON SUPPLY SPINDLE MAINT KIT
23	1	VP-Z-G22250	RIBBON TAKE-UP SPINDLE 8"
24	1	VP-Z-P1004238	8" PRINT HEAD, 203 DPI
25	1	TP-T15M8011RAP	SENSOR BRACKET
26	1	TP-404148	CLEVIS
27	1	VP-Z-G31197M	203 DPI ZEBRA MOTOR 8" WIDE
28	1	TP-T15M8042	RIBBON TAKE-UP PULLEY
29	1	TP-T2Z-8500-08Z	MICRO ADJUST ASSEMBLY
30	1	TP-T15M8007	BELT TENSIONER
31	1	TP-504138	CAM FOLLOWER
32	1	TP-T2Z2004	PIVOT SHAFT
33	2	TP-T14M1035	GUIDE ROD HOLDER
34	1	TP-503113	BELT
35	2	TP-108099	COMPRESSION SPRING

36	2	TP-108127	SPRING
37	2	TP-102119	NYLON WASHER
38	1	TP-T15M8043	LOCATING SPACER
39	1	TP-T15M8038	WEAR SURFACE
40	2	TP-401277	ELBOW, 1/4 TUBE
41	1	TP-T15M8040	BAG-OUT SENSOR BRACKET
42	2	TP-106304	10MM DOWEL PIN
43	1	TP-T6A1057	COLLAR STOP

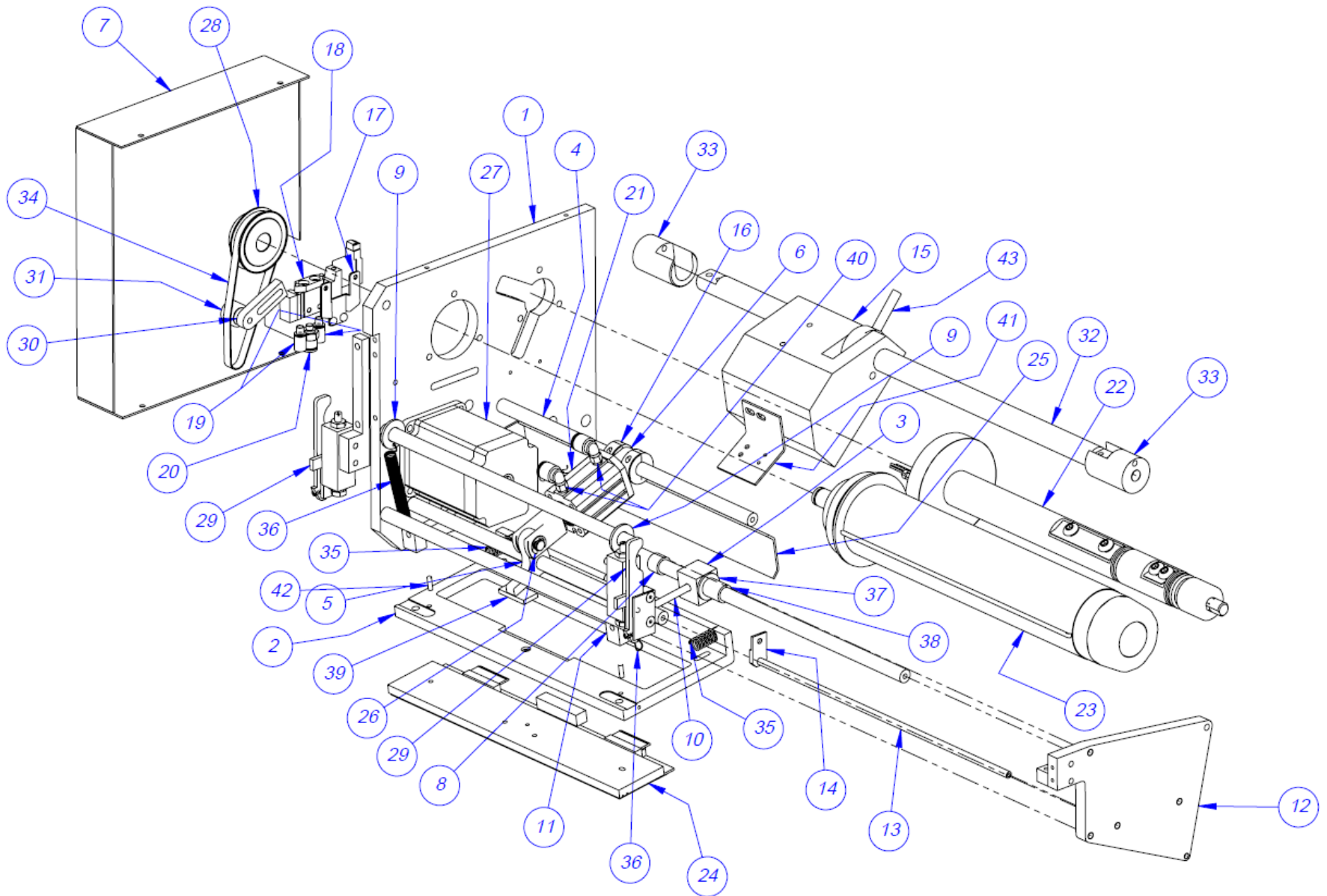

5.16 Roll-A-Print 2800 System Layout

T-ROLL2800

ITEM NO.	QTY	PART NO.	DESCRIPTION	PAGE NO.
1	1	TA-T6-60050	STAND ASSEMBLY	38
2	1	TA-T2Z1000	ELECTRONICS ASSEMBLY	49
3	1	TA-T2Z8010RAP	FOUR-INCH PRINTER	54
4	1	TA-T60052	IOP ASSEMBLY	48
5	1	TA-T60051	DANCER ASSEMBLY RAP1400	39
6	1	TA-T6000	MAIN BODY ASSEMBLY	44
7	1	TO-T1-WINDUP	DRIVEN REWIND UNIT	42
8	1	T-Ti1000Z	INLINE THERMAL PRINTER	66
9	1	TP-T6A1062	WEB ROD	--
10	1	TP-T6A1064	TIE PLATE	--
11	1	TP-T6A1065	TIE SPACER	--

NOTE: The T-Ti1000Z Inline Thermal Printer is inverted when mounted to the Roll-a-Print 1400 to create the Roll-a-Print 2800. The drawings in this manual reflect the T-Ti1000Z printer as it is right-side-up.

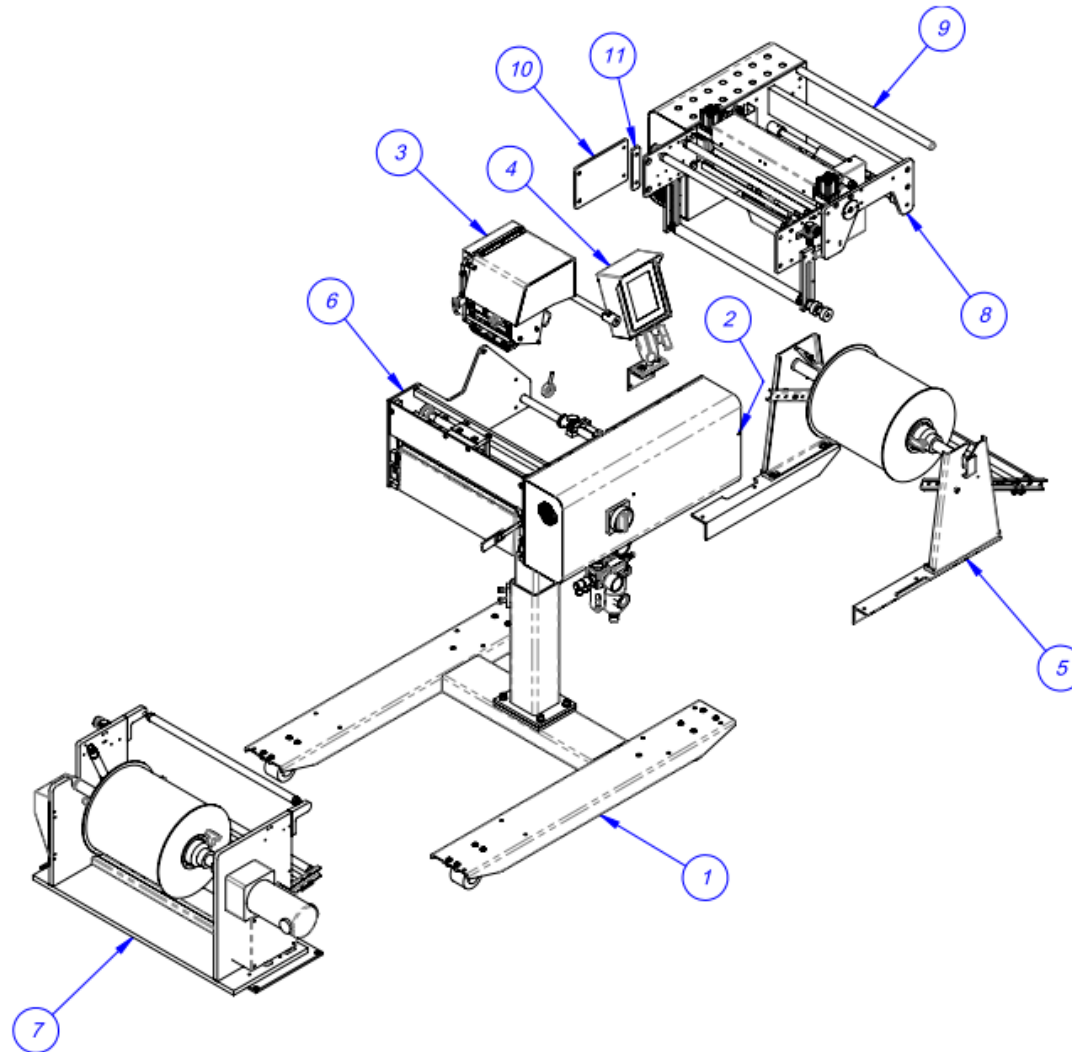

5.17 Ti-1000Z Inline Thermal Printer

T-Ti1000Z

ITEM NO.	QTY.	PART NO.	DESCRIPTION
1	1	TA-T2Z-2000	MOUNTING ASSEMBLY
2	1	TA-T2Z-8000	ZEBRA PRINTER ASSEMBLY
3	1	TA-T2Z-2000-1	PRINTER NIP ASSEMBLY
4	1	TA-T2Z-1000	PRINTER ELECTRONICS ASSEMBLY
5	1	TA-T2Z-4000	PRINTER REGISTER

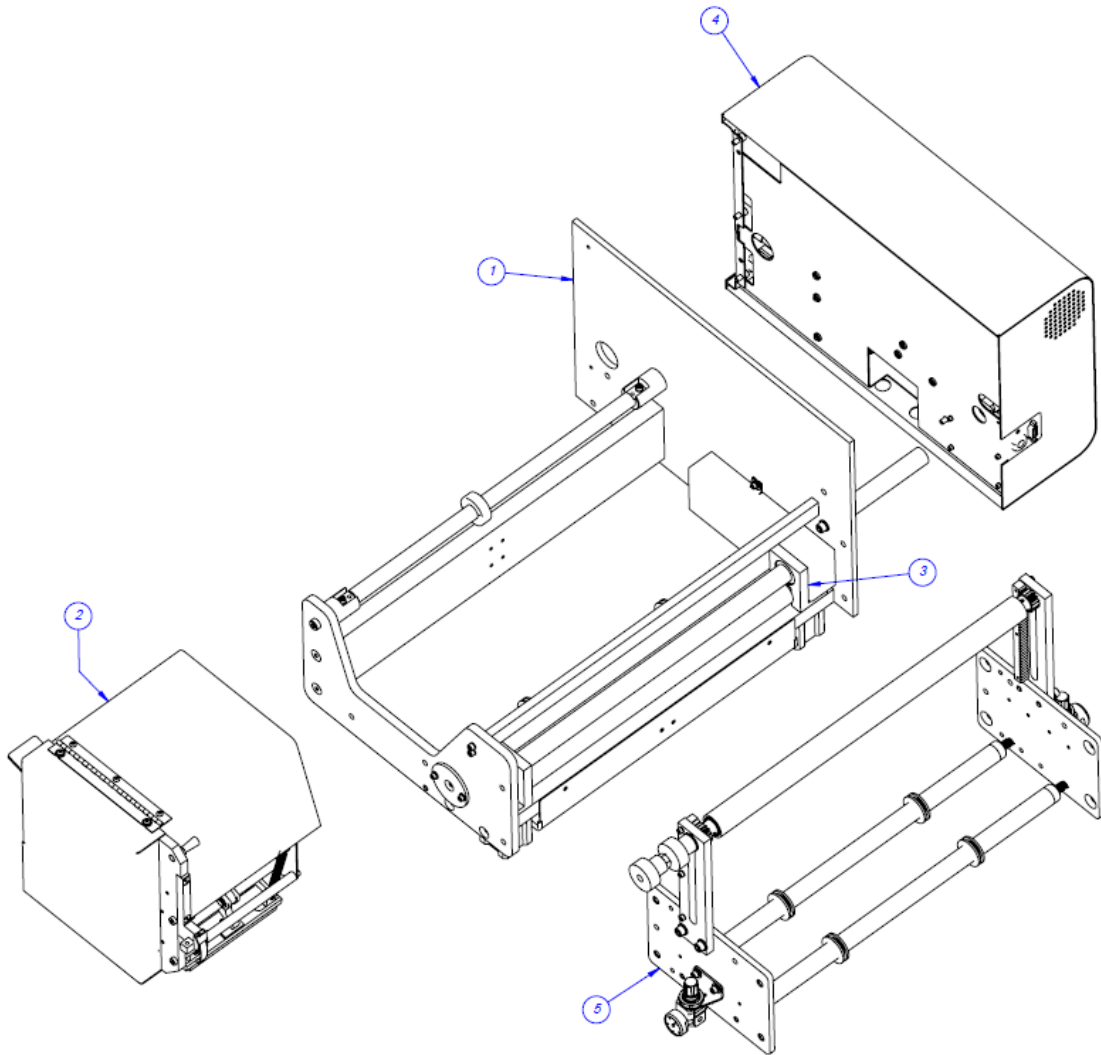

5.18 Mounting Assembly

PN: TA-T2Z-2000

ITEM NO.	QTY.	PART NO	DESCRIPTION
1	1	TP-T2Z2002-1	MOUNTING SIDE PLATE - RIGHT SIDE
2	1	TP-T2Z2002-2	MOUNTING SIDE PLATE - LEFT SIDE
3	1	TP-T2Z2007	SUPPORT BRACE
4	2	TP-T14M1035	GUIDE ROD HOLDER
5	1	TP-T2Z2004	PIVOT SHAFT
6	1	TP-T2Z2005	LATCH BAR
7	1	TP-T2Z2011	BEARING PLATE
8	2	TP-504097	BEARING
9	1	TP-T2Z2006	PRINT HEAD ROLLER
10	1	TP-T1MC00052	STANDARD ROLLER
11	1	TP-T2Z2022	TUBING COVER
12	1	TP-T2Z2013	BELT COVER
13	1	TP-T2Z2012	COVER PANEL STAND-OFF
14	1	TP-T15M8007	BELT TENSIONER
15	1	VP-Z-G46199M	300 DPI ZEBRA MOTOR
16	2	TP-106106	SLOTTED SPRING PIN
17	2	TP-108099	COMPRESSION SPRING
18	2	TP-111010	SPRING CLOSURE COLLAR
19	1	TP-111108	SHAFT COLLAR
20	1	TP-104186	SPACER
21	1	TP-504138	CAM FOLLOWER
22	1	TP-306010	RUBBER EDGE TRIM
23	1	TA-T2Z-2000-1	PRINTER NIP ASSEMBLY

Note: For 300 DPI models, substitute VP-Z-G46199M Motor for Item 15, and omit Item 14 (Belt Tensioner).

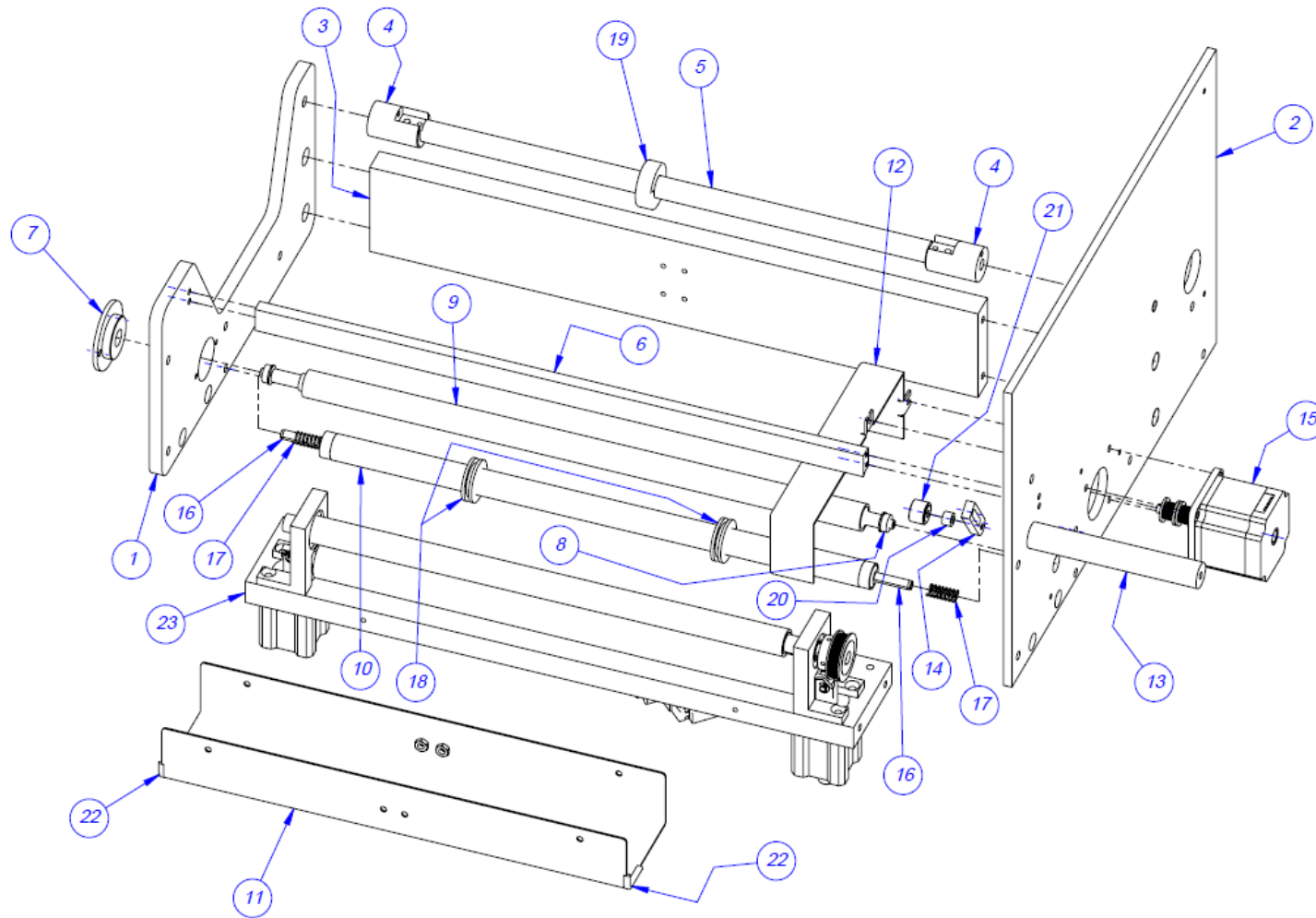

NOTE:
 ITEM 17 "VP-Z-46198M ZEBRA MOTOR" IN THIS ASSEMBLY IS TAKEN FROM ASSEMBLY
 TA-T15-8000 AND REPLACED IN THAT ASSEMBLY WITH MOTOR TP-501155.

THE PARTS THAT MAKE UP THE PRINTER NIP ASSEMBLY TA-T2Z2000-1 ARE ALSO PART
 OF THIS ASSEMBLY. SEE DRAWING TA-T2Z2000-1 FOR THE REMAINING PART NUMBERS

5.19 Nip Roll Assembly

PN: TA-T2Z-2000-1

ITEM NO.	QTY.	PART NO.	DESCRIPTION
1	1	TP-T2Z2016	NIP ROLL SUPPORT BRACE
2	2	TP-403236	AIR CYLINDER
3	2	TP-103533	SCREW, 1/4-28 x 1 SET
4	2	TP-T2Z2029	MODIFIED CLEVIS
5	2	TP-T2Z2028	BEARING HOUSING
6	1	TP-T2Z2027	DRIVEN NIP ROLL
7	2	TP-504129	RADIAL BEARING
8	1	TP-T2Z2019	DRIVEN NIP ROLL
9	2	TP-401277	ELBOW, 1/4 TUBE
10	2	TP-402186	FLOW CONTROL VALVE, #10-32
11	2	TP-401254	UNION TEE, 1/4"
12	1	TP-402175	AIR VALVE BRACKET, SX3000-16-1A
13	1	TP-402255	AIR VALVE WITH CONNECTOR
14	2	TP-504106	BEARING, NICE
15	1	TP-T2Z2025	NIP ROLL DEAD SHAFT
16	1	TP-T2Z2026	ROLLER TUBE
17	2	TP-404263	MUFFLER
18	1	TP-401265	STRAIGHT CONNECTOR
19	1	TP-T2Z2032	SENSOR BRACKET
20	1	TP-216112	PHOTOELECTRIC SENSOR

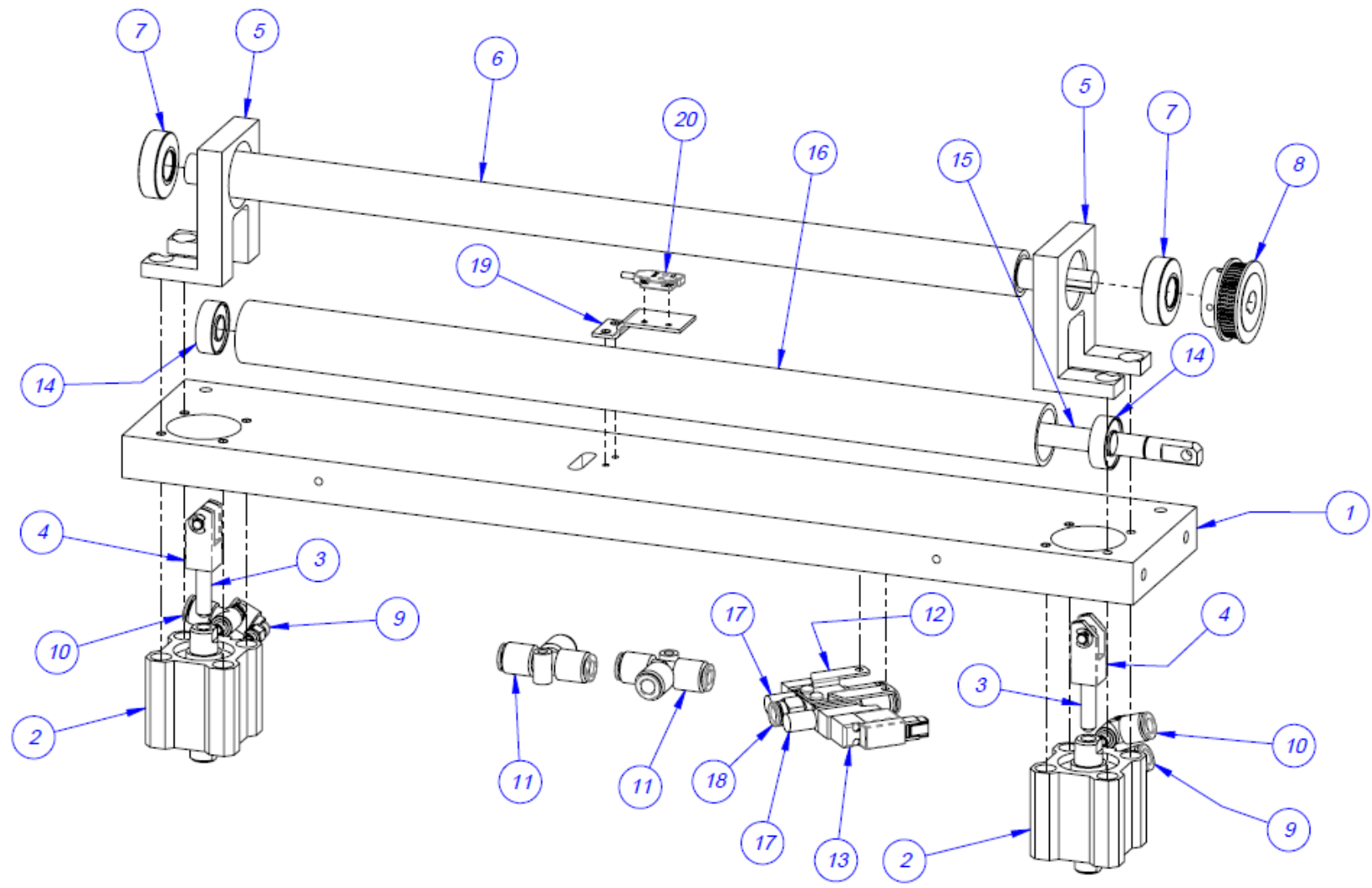

5.20 Printer Register

PN: TA-T2Z-4000

ITEM NO.	QTY.	PART NO.	DESCRIPTION
1	2	TP-T2Z4001	PRINTER MOUNTING BRACKET
2	2	TP-T2Z4002	RACK MOUNT
3	2	TP-406259	MINI-REG ASSEMBLY
4	2	TP-T2Z4003	SHORT GEAR RACK
5	1	TP-T2Z4005	GEAR
6	1	TP-T2Z4004	GEAR
7	2	TP-107108	FLANGED BUSHING
8	1	TP-T2Z4007	ROLLER TUBE
9	2	TP-T1MC00052	GUIDE ROLLER (PRINT REG)
10	4	TP-106106	SPRING PIN
11	2	TP-T2Z4010	BUSHING CAGE
12	4	TP-108099	COMPRESSION SPRING
13	4	TP-111010	SPRING CLOSURE COLLAR
14	1	TP-106109	1/8" X 3/4" SLOTTED SPRING PIN
15	1	TP-T2Z4006	ROLLER SHAFT
16	2	TP-109149	HANDLE, KNURLED STEEL
17	1	TP-102126	WASHER, 3/8" EXTERNAL TOOTH LW
18	1	TP-101123	NUT, 3/8-16 HEX JAM NUT
19	1	TP-102144	WASHER, 3/8" FLAT

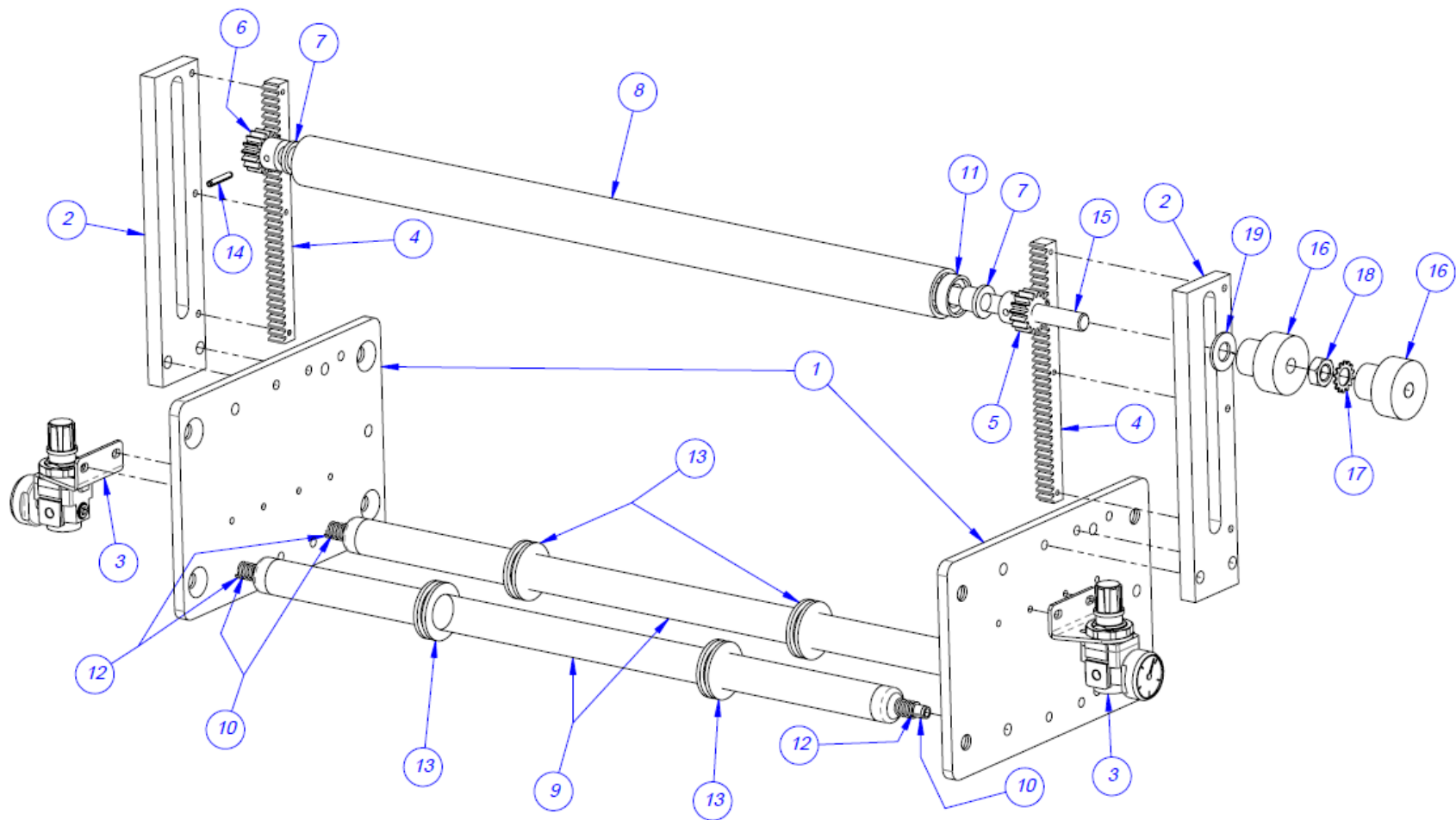

5.21 Notes

Date:

Note:

Date:	Note: