

# T-1000-S14

# Advanced Poly-Bagger™ / US-9000 Net-Weigh Scale

---

Combined Operation Guide, Version 1  
Setup, Operation and Parts Manual



---

1331 Emmitt Road • Akron, OH 44306 • 1-800-754-4403 • fax 330-785-4010 • [www.advancedpoly.com](http://www.advancedpoly.com)

## Acknowledgments

---

Written by: Jen Sprandel  
Reviewed by: Stuart Baker

## Copyright

---

2013 (Version 1) Advanced Poly-Packaging, Inc. (APPI). All rights reserved.

This manual and the program operating the equipment described in it are copyrighted. You may not copy this manual in whole or part without the consent of Advanced Poly-Packaging, Inc.

All information pertaining to the promotion, sale, distribution, operation, and maintenance of the combined US-9000 Scale and the T-1000-S14 Advanced Poly-Bagger including this manual, drawings, schematic, wiring diagrams, video, brochures, specification sheets, figures, charts, or any other information, due to its proprietary design and manufacture remain the property of Advanced Poly Packaging, Inc. Unauthorized duplication, distribution, or disclosure to third parties without the express permission of Advanced Poly-Packaging, Inc. is strictly prohibited.

## Trademarks

---

US-9000 and T-1000-S14 are trademarks of Advanced Poly-Packaging, Inc. Advanced Poly-Packaging, Inc. owns also the following trademarks: Advanced Poly-Bags, Advanced Poly-Bagger, Seal-a-Print, Roll-a-Print, Twin-Seal, Advanced Poly-Pack, Advanced Poly-Bag, Advanced Bag.

## Limited Warranty and Disclaimer

---

Warranty period is 12 months or 1,000,000 cycles whichever comes first. The warranty commences on the date of delivery of the equipment to the Purchaser. APPI warrants to the Purchaser that the equipment is free from defects in workmanship or material under normal use and service. During the warranty period, APPI agrees to repair or replace, at its sole option, without charge to Purchaser, any defective component part of the equipment. To obtain service, Purchaser must return the equipment or component to APPI or an authorized APPI distributor or service representative in an adequate container for shipping. Any shipping charges, insurance, or other fees must be paid by Purchaser and all risk for the equipment shall remain with Purchaser until such time as APPI takes receipt of the equipment. Upon receipt, APPI, the authorized distributor or service representative will promptly repair or replace the defective component and then return the equipment or component to Purchaser, shipping charges, insurance, and additional fees prepaid. APPI may use reconditioned or like new parts or units, at its sole option, when repairing any component or equipment. Repaired products shall carry the same amount of outstanding warranty as from original purchase. Any claim under the warranty must include a dated proof of delivery. In any event, APPI's liability for defective components or equipment is limited to repairing or replacing the components. This warranty is contingent upon proper use of the equipment by Purchaser and does not cover: expendable component part such as Print Heads, thermocouple wire, heater cartridge, rollers, bushings, and the like; or if damage is due to accident, unusual physical, electrical, or electromechanical stress, neglect, misuse, failure of electric power, water damage (from airlines), improper environmental conditions, transportation, tampering with or altering of the equipment, packaging of corrosive, or contaminating products or other products damaging to components, and equipment or components not owned or in the possession of original Purchaser. APPI will not be liable for loss of production, profits, lost savings, special, incidental, consequential, indirect, or other similar damages arising from breach of warranty, breach of contract, negligence, or their legal action even if APPI or its agent has been advised of the possibility of such damages or for any claim brought against the Purchaser by another party. This warranty allocates risks of equipment failure between Purchaser and APPI. APPI's pricing reflects this allocation of risk and the limitations of liability contained in this warranty. The warranty set forth above is in lieu of all other express warranties, whether oral or written. The agents, employees, distributors and dealers of APPI are not authorized to make modifications to this warranty, or additional warranties binding on APPI. Accordingly, additional statements such as dealer advertising or presentations, whether oral or written, do not constitute warranties by APPI and should not be relied upon. Warranty on equipment is considered void when outstanding balances become delinquent (over 30 days late - 60 days after ship date). Equipment Integration to other Equipment: APPI assumes no responsibility for the integration of its products to other products or within a system unless APPI performs the integration, testing and provides the results of the tests to the purchaser in writing. Furthermore, APPI assumes no responsibility for bag sizing whether suggested or recommended.

# TABLE OF CONTENTS

<b>Chapter 1: Introduction</b>	<b>7</b>
1.1 Introduction.....	8
1.2 Overview.....	8
1.3 Special Features .....	8
1.4 System Integration .....	9
1.5 Additional Options.....	9
1.6 Using This Manual.....	11
1.7 Warranty Registration.....	12
<b>Chapter 2: Getting Started</b>	<b>13</b>
2.1 Getting Started .....	14
2.2 Safety, Risks .....	14
2.3 Installation Procedures.....	15
2.4 Air and Power Requirements .....	15
2.5 Assembly Instructions.....	16
2.6 Air and Power Hookup .....	16
2.7 Main Power.....	16
2.8 T-1000-S14 Bag Threading .....	17
2.9 System Cycle Operation .....	17
2.10 Note on Adjustments.....	18
<b>Chapter 3: Touch Screen Operation</b>	<b>23</b>
3.1 Chapter Summary .....	24
3.2 Touch Screen Identification .....	24
3.3 Touch Screen Specifications / Features .....	24
3.4 Touch Screen Contrast Adjustment .....	24
3.5 Touch Screen Program Overview .....	24
3.6 Introduction Screen.....	25
3.7 Main Menu.....	25
3.8 Bagger Operation Screen .....	25
3.9 Scale Operation Screen .....	26
3.10 Bagger Settings Screen .....	28

A. Fill Time .....	28
B. Air Pulse .....	29
C. Seal Point.....	29
D. Seal Time.....	29
E. Reverse .....	29
F. Blow Off .....	29
G. Index Speed .....	29
H. Seal Temperature.....	30
3.11 Scale Settings Screen .....	30
3.12 Scale Piece Sample Screen .....	32
3.13 Bagger Options Menu .....	33
A. LS-10 Load Shelf .....	33
B. CS-10 Compartment Seal .....	34
C. FS-10 Flat Seal Assembly.....	35
D. TS-10 Trim Seal .....	35
E. TS-10 Twin Seal .....	36
F. ES-10 E-Stop Circuit.....	36
G. LC-10 Light Curtain .....	37
H. AF-10 Accumulating Funnel .....	38
I. CF-10 Counting Funnel.....	40
J. DF-20 Part Diverter (Diverting Funnel) .....	42
K. BO-30 Bag Opening Device.....	43
L. ST-10 Stack Light Option .....	44
M. MV-10 Seal Validation.....	45
N. BV-10 BarCode Reader Option.....	45
O. Ti-1000 Inline Printer .....	46
P. Ti-1000Z Printer.....	46
Q. NBO Printer.....	46
3.14 Counters Screen .....	47
3.15 Job Save / Job Load .....	47
3.16 Recipe Management Screen.....	48
3.17 Bagger Auxiliary Options .....	49
3.18 Scale Auxiliary Screen.....	49
3.19 Scale Weight Log.....	50
3.20 Weight/Count History .....	50
3.21 Temperature Graph .....	51
3.22 Bagger Production Chart.....	51

3.23 Production Log .....	51
3.24 Alarm Tracking.....	52
3.25 Technical Assistance.....	53
3.26 Pass Code Setup Screen .....	53
3.27 PLC Info .....	54
3.28 Bagger Options Enable Screen.....	55
3.29 Bagger Solenoid Activation .....	55
3.30 Bagger Factory Settings.....	56
3.31 Scale Factory Settings.....	57
3.32 APPI Factory.....	59
3.33 Printer Status Screen .....	59
3.34 Warning and Message Screens.....	60
<b>Chapter 4: Adjustments, Maintenance and Troubleshooting</b> .....	<b>61</b>
<hr/>	
4.1 Bagger Machine Adjustments .....	62
A. Tracking and Alignment Adjustments.....	62
B. Compression (Nip) Roller Adjustment .....	62
C. Dancer Assembly Adjustments (Roller Shaft).....	65
D. Dancer Bar and Brake Strap Adjustment.....	65
E. Upper Roller Guides .....	65
F. PTFE Adjustment .....	65
G. PTFE Replacement.....	66
H. Pressure Bar Adjustment .....	66
I. Sealer Cylinder Adjustment .....	66
J. Pressure Bar (Rubber) Replacement .....	69
K. Anti-Jam Adjustment.....	69
L. Heater Cartridge Replacement .....	72
M. Replace Thermocouple Wire .....	74
4.2 Scale Adjustments.....	76
A. Bowl Discharge Position .....	76
B. Skivers .....	76
C. Level Switch .....	76
D. Bowl Drive .....	77
E. Erratic Feeding of the Bowl .....	77
F. Dead Spots in the Bowl.....	77
G. Adjustment of the Coil Gap.....	77
H. Spring “Tuning” .....	78
4.3 Bagger Preventative Maintenance and Scheduled Maintenance .....	78

A. Preventative Maintenance Checklist.....	78
B. Scheduled Maintenance Chart .....	79
C. Preventative Maintenance Chart .....	80
D. Spare Parts Kits .....	80
4.4 Bagger Troubleshooting Guide.....	82
A. Troubleshooting Checklist.....	82
B. PLC IO Listing .....	83
4.5 Scale Troubleshooting Guide.....	84
A. Troubleshooting Checklist.....	84
B. PLC IO Listing .....	84
4.6 Electrical Drawings.....	84
4.7 Troubleshooting Notes/Technical Support Information.....	85
Chapter 5: Parts and Drawings	91
<hr/>	
5.1 Electronics Module	94
5.2 Touch Screen Assembly	96
5.3 Stand Assembly	98
5.4 Scale Head Assembly	100
5.5 Dancer Assembly	102
5.6 Bowl Assembly	104
5.7 Chute Assembly	106
5.8 Supply Hopper Assembly	108
5.9 Head Assembly	110
A. Main Frame Assembly.....	112
Upper Roller Assembly .....	114
B. Electrical Panel .....	116
C. Sealer Frame Assembly: Drop Frame.....	118
Pressure Bar Subassembly .....	121
Heater Bar Subassembly.....	123
PTFE Guide Subassembly .....	125
Grooved Roller Mounting Subassembly.....	127
Bag Finger Grounding Subassembly .....	129
Latch Subassembly .....	131
Manifold Subassembly .....	133
D. Flat Load Shelf Assembly .....	135
E. E-STOP Assembly .....	137

This page intentionally left blank.

# Chapter 1: Introduction

---

Welcome

Overview

Special Features

System Integration

Additional Options

Using This Manual

Registration Information



## 1.1 Introduction

Now that you have decided to upgrade your packaging facilities with the combined T-1000-S14 Advanced Poly-Bagger and US-9000 Net-Weigh Scale from Advanced Poly-Packaging, Inc., we thank you for selecting our equipment, materials and service. Where labor reduction and fast changeover are important, the T-1000-S14/US-9000 system accurately feeds product to a vibratory bowl and then to a scale before discharging product directly to the T-1000-S14. The T-1000-S14/US-9000 uses Advanced Poly-Bags (pre-opened bags on rolls), manufactured by Advanced Poly-Packaging, Inc. Extensively equipped with several built-in, ready-to-use options, the T-1000-S14/US-9000 can package various industrial, medical, molded and food products. With a wide range of bag sizes (2" x 3" [standard frame only] to 14" x 30") and mil thickness (1 mil to 5 mil), we hope the T-1000-S14/US-9000 will meet all of your bagging needs.

## 1.2 Overview

The system is designed to lower your packaging costs with high speeds, versatility, reliability and simplicity.

**High Speeds:** This combined system feeds product quickly and consistently from a conveyor to a vibratory bowl before dropping to the scale. The product flow is controlled and monitored for optimal productivity. When the desired weight is achieved, product is “dumped” into a poly-bag that is automatically opened, sealed and torn off at a very high rate of speed. Actual packaging speed depends on the bag size, equipment options, product characteristics and method of loading.

**Versatility:** This system is ideal for numerous short runs with virtually no production loss for job changeovers since all that is required is a roll change and recalling settings from memory.

**Reliability:** Crafted from the highest quality components and materials to withstand the most rigorous manufacturing environment, the rugged frame guarantees long life and usefulness with minimal maintenance.

**Simplicity:** A user-friendly, menu-driven touch screen program allows operators to set up the bag, options and auxiliary equipment, save the settings in memory and recall those settings for repeat runs.

## 1.3 Special Features

The combined T-1000-S14/US-9000 is equipped with the following standard features:

**Energy Conservation and Component Saver:** To extend its life and conserve energy in your plant, this system is programmed to sequentially shut components down when not in use for extended periods. Electric current to the heater bar will discontinue and place the T-1000-S14/US-9000 in the stop mode during a preset period of nonuse. Shortly thereafter, air flow will shut off, preserving compressed air. A screen saver is also provided.

**Pass Code Protection:** As an option, settings screens can be protected from alteration by unauthorized individuals. Once turned on, this function acts as a “screen save” feature. A timer causes the pass code screen to be displayed from the Operation screen. Factory settings are protected by a Level 1 pass code, which should only be provided to authorized maintenance personnel.

**Predetermined Counter:** Preset the T-1000-S14/US-9000 to stop after a predetermined number of bags have been packaged. Set the quantity of finished bags to complete a work order or fill a shipping container. Once the work order is complete or the container is full, the T-1000-S14/US-9000 stops to alert the operator to begin the next work order or to push aside the box to begin filling another. Pressing anywhere on the screen resets the counter and starts the bagging operation again with minimal delay.

**Totalizing Counter:** Reset this counter at the beginning of each shift or day to record packaging production over a period of time.

**Maintenance Counter/Chart:** Periodically check this counter to determine preventative maintenance/component inspection intervals for inspection / maintenance criteria and intervals.

**Continuous Strip Option:** Leave bags connected in a predetermined number of strips of sealed bags that are connected to each other in a strip.

**Communications Port:** Allows for auxiliary communications.

**Anti-Jam Device:** During the loading and sealing operation, this device will detect obstructions and automatically reverse the pressure bar and discontinue the cycle operation.

**Recipe Management System:** The combined T-1000-S14/US-9000 allows for recipe management, a system that allows the operator to create, manage and store “recipes” of past jobs settings from multiple machines operating in a system. These recipes can be saved and applied to future jobs to make operation faster and easier.

## 1.4 System Integration

The combined T-1000-S14/US-9000 is preprogrammed to work automatically with major brand feeders, volumetric fillers, auger fillers and infeed conveyors. As an OEM for numerous equipment manufacturers of infeed systems, we can offer the best available system. However, APPI cannot be responsible for the successful integration of third party equipment, unless approved and integrated by APPI.

**FREE CONSULTATION AND PRODUCT EVALUATION:** We invite you to call to discuss your packaging requirements and our free product packaging analysis.

## 1.5 Additional Options

Although the combined T-1000-S14/US-9000 is equipped with many built-in options, various auxiliary options and equipment can easily be added for special purpose packaging. The following options may be purchased from Advanced Poly-Packaging, Inc:

**AF-10 Accumulating Funnel:** A special purpose funnel that collects and holds product until it is ready to be dropped. A funnel to help contain the product can also be inserted.

**Bag Deflator:** This option quickly mounts to the sealer bar and squeezes the air from the bag while sealing.

**Bag in Bag Option:** A conveyor feeds bagged product to a second bagger to be bagged again.

**Bag Out Sensor:** If the bag material ends, a message will be displayed indicating that the machine is out of bags or that a threading or web breakage issue has occurred.

**Base Height Adjustment:** An electronic mechanism that raises or lowers the base of the bagger, allowing for more versatility and convenience. Without this option, the operator must raise or lower the bagger manually.

**BO-20 Bag Open Detector:** This option will detect whether or not a bag is blown open, or whether or not a funnel is inserted into the bag for validation that the bag is ready to receive product.

**BO-30 Bag Opening Device:** This device enters the bag with one or more “fingers” and pulls the bag open to a stop.

**BV-10 Barcode Verifier:** Verifies that a barcode is readable. If no barcode is detected, or if a barcode is not correctly formatted (as per software settings in the barcode verifier), then a “No Read” message will be displayed.

**CF-10 Counting Funnel:** This option automatically cycles the bagger when a preset number of parts have fallen through the funnel.

**CS-10 Compartment Seal:** Seals the bag twice to create two separate compartments within the same bag.

**DF-10 Diverting Funnel:** This feature is used to count bags from the bagger and divert them for further packaging operations, including counting into cartons.

**E-Stop:** This option can be used to stop the cycle operation of the T-1000-S14 and possibly other auxiliary infeed or outfeed equipment purchased with the T-1000-S14.

**FS-10 Flat Seal Assembly:** Helps decrease / eliminate wrinkles in the seal by pulling the sides of the bag. Increases bag integrity.

**LAN Connection:** Provides for Ethernet communication.

**LC-10 Light Safety Curtain:** If funnels are removed, APPI highly recommends the addition of this option to prevent injuries. This option, when activated, prevents inputs to valves that cause the seal bar to activate. Additionally, the stepper motor stops when blocked.

**LS-10 Load / Support Shelf:** Provides support for heavier packages when dropped into bag. Sizes: 10", 15" or 20" long.

**MV-10 Seal Validation:** Additional components provide a secondary means of detecting a failure or out of range condition for components that affect seal quality.

**NBO Next Bag Out Printer:** An inline printer installed within the T-1000-S14 capable of printing the next bag out in the bagging sequence. This feature prevents mislabeling of pharmaceuticals, prescriptions or high cost items and also allows part numbers or other printing information to be changed with every bag.

**OFS-10 Output Fault Signal with SL-10 Stack Light:** For automatic bagging operations with third party or production equipment, this signal provides a fault when the bagger is inoperative (due to out of bag conditions or other faults).

**PB-20 Dual Palm Buttons:** Decreases the possibility of injury to hands and fingers. The operator must push two buttons simultaneously to actuate the seal bar.

**Photo Eyes:** APPI can provide different types and configurations of sensors to meet the specific needs of your product.

**Roll-a-Print 1400 or 2800 Single or Dual Thermal Inline Printer:** Prints bar codes and graphics directly to the surface of the front or both the front and back of the bag.

**Special Tooling:** Bowls can be custom-tooled to provide for the orientation requirements of special parts.

**Ti-1000 Thermal Transfer Inline Printer:** Print bar codes, graphics, etc. by downloading pre-formatted labels, generated via label software. (PC or Terminal and software required)

**TS-10 Trim Seal Assembly:** Trims excess film from the bag above the seal to enhance the appearance of the package. Great for retail products.

**Twin-Seal™**: Seals the bag a second time, 3/8" from the first seal, for additional bag integrity.

**UC-2400 Vibratory Parts Counter**: Automatic parts counter feeds fasteners, electronic components, injected molded parts and many other types of product, then drops the final count into the bag, carton or infeed conveyor.

**UF-2000 Takeaway Conveyor**: Removes packaged product to a packing station or directly feeds a carton or table, conveying the product from floor level. The conveyor fits perfectly underneath the T-1000-S14 and takes the product away. Small, lightweight and equipped with castors, use this conveyor anywhere in the plant. Designed for 24 hour / 7 days a week operation.

**UF-5000 Infeed Conveyor**: Kit packaging infeed conveyor. Instead of loading parts directly into the bag, load parts into compartments on the conveyor. Packaging kits can be loaded into the compartments by hand or automatically with parts or scales.

**US-4000 Check Weigh Scales**: When you must guarantee the contents of the bags or kits, APPI offers check weigh scales with incredible accuracy, speed and reliability. A history of weighments is standard, along with job / recipe saves.

**US-5000 / 7000 / 9000 Semiautomatic (US-5000) or Automatic Scale (US-7000 and US-9000)**: Feeds a weighed / counted batch of product into bags.

**Vibratory Hopper with Leveling Arm**: A supply hopper, triggered by a level switch designed to keep the bowl filled to a consistent level, provides a greater accuracy of parts flow. The leveling switch may be in the form of a leveling arm, an ultrasonic sensor or a photo optic sensor.

Other options may have been added since the date this list was printed. Please call for additional or custom options pricing.

## 1.6 Using This Manual

This manual functions as one manual for both the T-1000-S14 and the US-9000. Many sections of the manual will apply to both machines. However, certain sections of this manual will only pertain to the T-1000-S14, while other sections will only pertain to the US-9000. These sections will be properly noted.

The following manual conventions are frequently used to assist in understanding important information, to alert the operator of potentially dangerous or damaging practices and to describe the normal functions of the T-1000-S14/US-9000.

- Text Normal text.
- *Italics* Used for emphasis.
- **Boldface** Used to identify heading names and touch screen buttons.
- **CAUTION:** Warning messages. To avoid physical harm, damage to equipment or damage to the product, be sure to read these messages carefully.
- *NOTE:* Identifies important information.

## 1.7 Warranty Registration

This section must be completed and returned to Advanced Poly Packaging, Inc. to register the combined T-1000-S14 Bagger and US-9000 Scale system for Warranty Protection.

Serial Number:

---

(Serial number located on the back panel)

Company Name and Address

Contact Name(s) / Title(s) / Phone Number

<hr/> <hr/> <hr/>	<hr/> <hr/> <hr/>
-------------------	-------------------

Please fax or mail this page to:

Stuart Baker  
Advanced Poly-Packaging, Inc.  
1331 Emmitt Road  
Akron, OH 44306  
USA

Fax # (USA) 330-785-4010

# Chapter 2: Getting Started

---

Safety and Risks

Installation Procedures

Assembly Instructions

Height Adjustment

Air and Power

Bag Threading

Cycle Operation

## 2.1 Getting Started

This chapter describes procedures to receive and set up the combined T-1000-S14/US-9000, including uncrating instructions, environmental, air and power requirements, and assembly instructions. Additionally, this chapter describes safety precautions, how to turn on power to the system and how to properly thread bags through the bagger.

## 2.2 Safety, Risks

Many safety features have been included in the mechanical, electronic and pneumatic systems of this machine. Despite these safety precautions, operators may receive lacerations, minor burns, or crushed or broken bone injuries if they come in contact with the heater bar or any other moving components. Improper use, improper adjustments and neglect of preventative maintenance may result in serious personal injury. No special personal protective equipment is required to operate the equipment, but eye protection, gloves or other protection should be worn, depending on the characteristics of the product being packaged and the method of loading product.

Please carefully read the following precautions to operate the equipment properly and avoid injury:

- Initial setup of the machine must be performed by specialized personnel. Qualified service engineers should uncrate the equipment, assemble the equipment (if required), test and connect power sources, test the equipment for proper operation and otherwise set up the equipment for use.
- Do not attempt to adjust the height without assistance and without supporting the weight of the machine. Attempting to make a height adjustment without assistance could cause the machine to drop suddenly, causing severe injury. APPI offers several optional accessories that can reduce the risk of injury during height adjustments. These accessories include carts, motorized height adjustment components and stabilizing bars.
- Ensure that any height adjustments allow for sufficient movement of the operator. Improper height adjustments could negatively affect operator movement, causing strain, added stress, discomfort and fatigue.
- To avoid injury, do not operate the equipment if funnels, guards, covers or other access panels have been removed. If any of these safety measures have been removed or modified or if any openings have been increased, the operator will have access to moving components and extreme temperature areas that can cause crush, cut or burn injuries to hands or fingers.
- To avoid injury, do not reach under the equipment, guards or elsewhere under the machine. Do not place hands or fingers in the seal area or near the seal bar, heater bar, load shelf or other moving components.
- Do not remove or loosen fasteners on the frame. If loosened, the equipment may drop suddenly, causing injury or damage to the machine.
- Be careful when opening the seal frame as it may drop suddenly, causing injury or damage to the equipment.
- To avoid injury, avoid coming in contact with pinch points including rollers, automatic funnel doors or other moving components.
- To avoid injury, avoid contact with roller "fingers" as they may be sharp.

- Exercise care when adjusting or relocating the touch screen. Movement of the touch screen could cause unexpected movement of the machine and injury to the operator.
- Do not attempt to feed parts that are not suited to the machinery. Doing so could cause jams, damage to machinery and ejection of parts. For example, parts too large for the accumulating funnel may jam and eject when the door closes.
- If control or air pressure settings are set too high, higher noise levels may result from increased part on part contact or part on machinery contact. Limit these settings and add guards or covers to reduce airborne noise.
- Exercise extreme care when clearing jams, replacing materials, changing controls or mechanical settings, and cleaning internal parts. Be sure to de-energize energy sources prior to removing guarding. Failure to do so may result in unexpected movement or flying objects, which could cause crush, cut or eye injuries.
- Maintenance must be performed by specialized personnel. Qualified service engineers must remove guards or covers to gain access to electrical or mechanical areas.
- Maintenance must be performed regularly to ensure that the machine is operating properly and to protect against injury. Routine maintenance includes: periodic inspections, the replacement of worn or damaged components, the tightening of loose bolts or components, and regular cleaning and adjustments. Contact APPI and/or service centers for service support if there is not sufficient maintenance staff at your facility to perform regular maintenance.

## 2.3 Installation Procedures

The combined T-1000-S14 Advanced Poly-Bagger and US-9000 Net-Weigh Scale System is transported as a single unit in a custom crate designed to protect the machine during shipment. It is shipped completely assembled except for a few items that are easily attached during installation with final adjustment for proper placement of the touch screen, dancer assembly, foot switch, funnel and guards. If a printer is purchased with the T-1000-S14/US-9000 system, it will be bolted to the bagger.

**Unpacking:** This system can only be moved using a forklift. After removing the stretch wrapping, remove the outer crate from the skid. Unfasten the base support brace from the skid. Use a forklift to carefully lower the system from the skid. Transport the system to the operating location prior to attaching the touch screen and unfastening the dancer assembly.

**Operating Environment:** The system should be placed in an area free of excessive heat, moisture, dirt, dust, vibrations, air flow or other conditions that may affect the stability of the scale or cause incorrect readings from the load cell. Operating room temperature should range from 50°F to 100°F.

## 2.4 Air and Power Requirements

**Power Requirements:** Provisions must be made for a 110 VAC, 60 Hz line current with ground. The full load current is 12 Amps.

**CAUTION: A qualified electrician should ensure that the power outlets are properly grounded, voltages are as required and amperage capacity is sufficient. If the unit is not properly grounded, it will produce a shock and will not function properly.**

*NOTE: APPI recommends a dedicated 20 Amp circuit for the T-1000-S14.*

**Air Requirements:** At least 2 CFM free air is required, regulated to 60 PSI.



*NOTE: Air should be dry and oil-free.*

*NOTE: Running the machine at a higher PSI setting than 60 PSI will cause excessive wear and may cause damage to components on the machine or parts being packaged. The anti-jam function may also be adversely affected.*

## 2.5 Assembly Instructions

Choose an operating location considering traffic flow, availability of bag supplies, supply of product to be packaged, takeaway of finished packages, placement of auxiliary infeed equipment and placement of takeaway conveyor(s). At the operating location, remove any inner packaging, banding or wires.

**Touch Screen Assembly/Position:** The touch screen has been secured for transportation in a separate box with protective wrapping. Holding the touch screen to prevent it from falling, loosen the set screw located in the clamp collar at the top of the upper column. Pull the shaft from the clamp collar approximately 6" and tighten the collar. Holding the touch screen module, loosen the "ball" clamp lever and position the touch screen.

**CAUTION: To avoid damage to the touch screen module, hold the screen until it is in the desired position and then be sure the screws and ball clamp lever are securely tightened.**

**Dancer Assembly:** The dancer assembly, located on the stand at the rear of the system, is secured with wire ties during shipment. After the removal of the ties, the dancer should be checked to make sure that it will rotate freely in a semicircular path. The shaft assembly may then be inserted into the dancer frame brackets so it is over the brake strap for tension. The shaft assembly should be checked to insure that it rotates freely.

**CAUTION: The seal bar should not come in contact with the funnel during sealing. Raise the funnel to avoid contact.**

**CAUTION: To avoid injury, do not operate the T-1000-S14/US-9000 without a funnel, guard or covers properly positioned. APPI offers a variety of funnels and chutes. Guarding may need to be added to prevent operators from reaching in, around or under the guard or funnels.**

**CAUTION: To avoid injury, do not reach underneath guards while the machine is plugged in.**

## 2.6 Air and Power Hookup

This section describes in detail how to hook up air and power and the air and power requirements.

*NOTE: A qualified electrician should ensure power outlets are the required 110 VAC and properly grounded before hooking up the power.*

The air supply should be fed to the T-1000-S14 with 3/8 ID flexible tubing; this tubing affixes to the coupler adapter (quick disconnect not provided). Connect the air to the regulator by holding the regulator firmly in one hand and pushing the air line connector on the male regulator connector. After connecting air, the regulator should be adjusted so the gauge reads 60 PSI. Insert the power cord into a 110 VAC, 60 Hz, grounded power outlet.

## 2.7 Main Power

The main power switch for the T-1000-S14 and the US-9000 is located on the control module at the base of the machine. To turn the system on, turn both switches from the vertical OFF position to the horizontal ON position. The green Power light on the touch screen will illuminate and the Introduction screen will be displayed. The program version will also be identified. The Introduction screen will only appear for a few seconds until automatically changing to the Operation screen or Main Menu.

*NOTE: If the touch screen does not power up to the Introduction screen, see Chapter 4 for troubleshooting steps.*

## 2.8 T-1000-S14 Bag Threading

The first step to threading the machine is to place a roll of bags on the shaft. Remove one of the chucks from the shaft by loosening the chuck knob and slide the roll of bags over the shaft, locking the chuck pin in the small hole in the core plug. Tighten the knob. Replace the second chuck also locking the chuck pin to the core plug. Remove the tape from the bags so that the bags fall freely and hang down from the top of the roll towards the back of the machine. Insert the right side of the roll shaft in the right side of the shaft holder (circular holder). Then drop the roll shaft in the slot located on the left side of the dancer assembly.

Center the bags on the shaft by loosening the chuck knobs and sliding the roll of bags along with the chucks to the desired location. Ensure the chuck pins remain in the core plug holes when sliding left or right. Pull the bags over the roller immediately above the dancer assembly, then down between the roll of bags and the outer dancer roller. Pull the bags around the outer dancer roller, over the rear "guide" roller and into the back of the T-1000-S14. Push the bags at least halfway through the machine.

From the front of the T-1000-S14, lower the frame by slowly pulling the frame handle forward and downward while holding the guard assembly, supporting the weight of the seal frame assembly.

**CAUTION: You must support the weight of seal assembly while lowering it with the handle. Otherwise, you may drop the seal assembly possibly causing personal injury or damage to the equipment.**

Carefully reach inside and pull the bags through the front of the T-1000-S14 so that one bag is centered on the roller. Ensure only one bag extends through the front of the machine. Slowly raise the frame by pulling forward and upward on the handle while holding the bag in position. Holding the guide roller shaft, slide the roller guides within approximately 1/8" from the sides of the bag to assist the tracking of the web of bags.

**CAUTION: Roller "fingers" may be sharp. To avoid injury when reaching into the T-1000-S14, ensure that you do not come in contact with the roller "fingers."**

*NOTE: The roller guides are for fine adjustments only, after proper tracking has been achieved. If the web of bags is not properly tracking, make proper adjustments. If not tracking properly, the web of bags may "ride" up the side of the guides causing the bags to fold over.*

A threading diagram based on the configuration of the system and the options ordered is provided at the end of this chapter.

## 2.9 System Cycle Operation

If all prior installation procedures have been performed properly, the T-1000-S14/US-9000 should be in its operating location with air and power connected. All guards, funnels and covers should be securely fastened and in position.

Load parts into the hopper. Parts feed from the hopper into the vibratory bowl based on the level sensor in the bowl. The bowl vibrates and drives parts around and upward in the bowl until they exit into the scale hopper. When the desired batch weight is reached and the bagger provides a ready signal, the scale head gate opens and the batch drops into the bag. The pressure bar compresses the front of the bag to the back of the bag and the gripper plate. The seal bar actuates and seals the bag against the pressure pad. The drive rollers reverse to separate the bag at the perforation, the pressure bar and seal bar retract and the bag falls from the bagger.

*NOTE: If the T-1000-S14 is not up to temperature, the machine will not cycle unless the **SETUP / RUN** button is toggled to **SETUP**.*

*NOTE: The web of bags may track right or left for a few feet until “settled” on the web path. The roll of bags or the roller guide may require readjustments or realignment after the first few feet of bags are indexed.*

*NOTE: If bags and parts were delivered with the T-1000-S14 or the bag and part size was known to APPI, the T-1000-S14/US-9000 may be ready to run. Therefore, very few changes to the Settings screen will be required.*

## **2.10 Note on Adjustments**

Upon receipt, it is not unusual for the T-1000-S14/US-9000 to be out of alignment due to shipping and excessive handling. Unless physically damaged, the system will function properly after minor adjustments are accomplished. Refer to Chapter 4 for information on adjustments to the system.

**T-1000-S14/US-9000 THREADING DIAGRAM**  
**SINGLE DANCER**

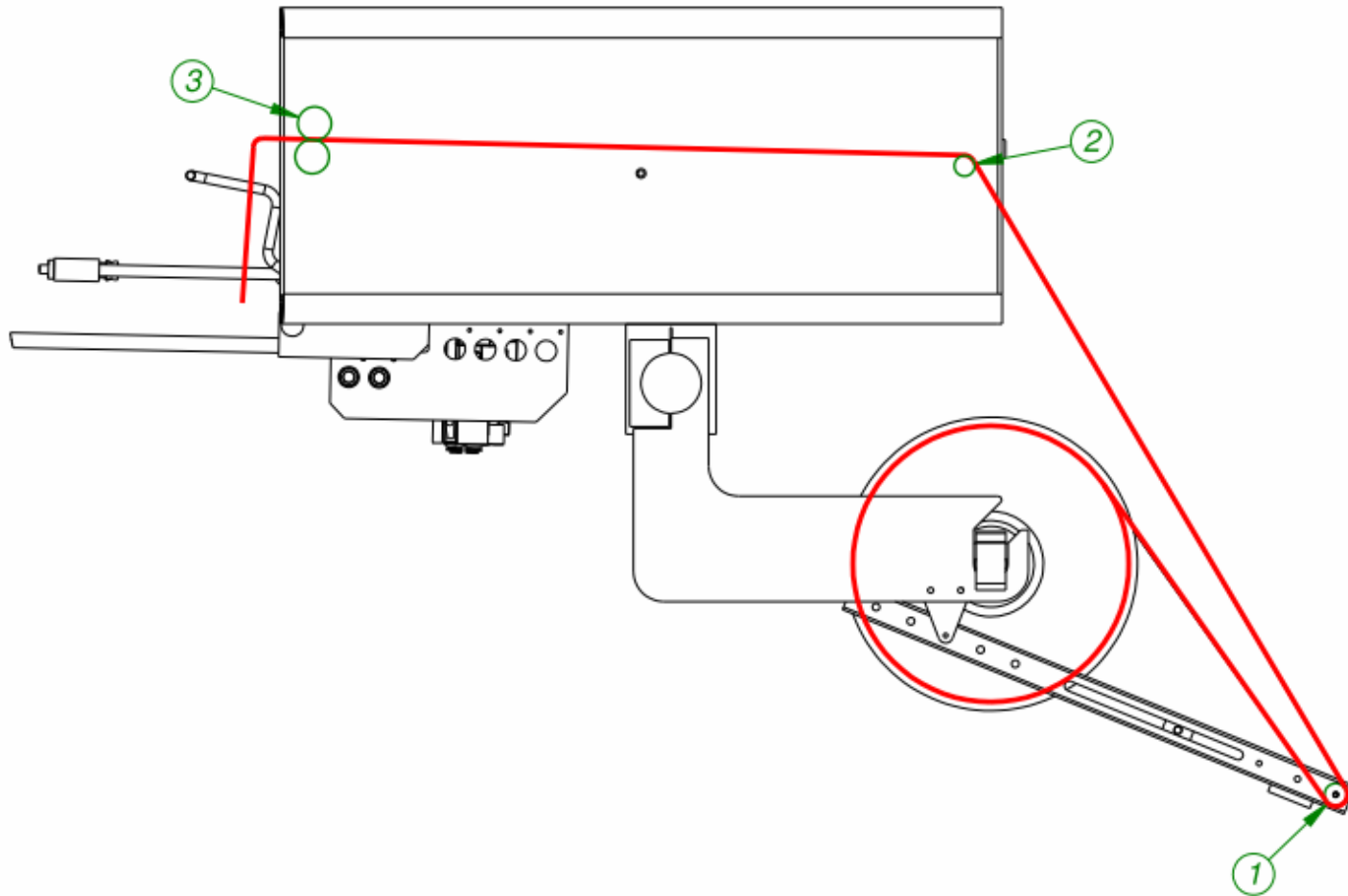

**T-1000-S14/US-9000 THREADING DIAGRAM**  
**SINGLE DANCER WITH TI-1000Z PRINTER**

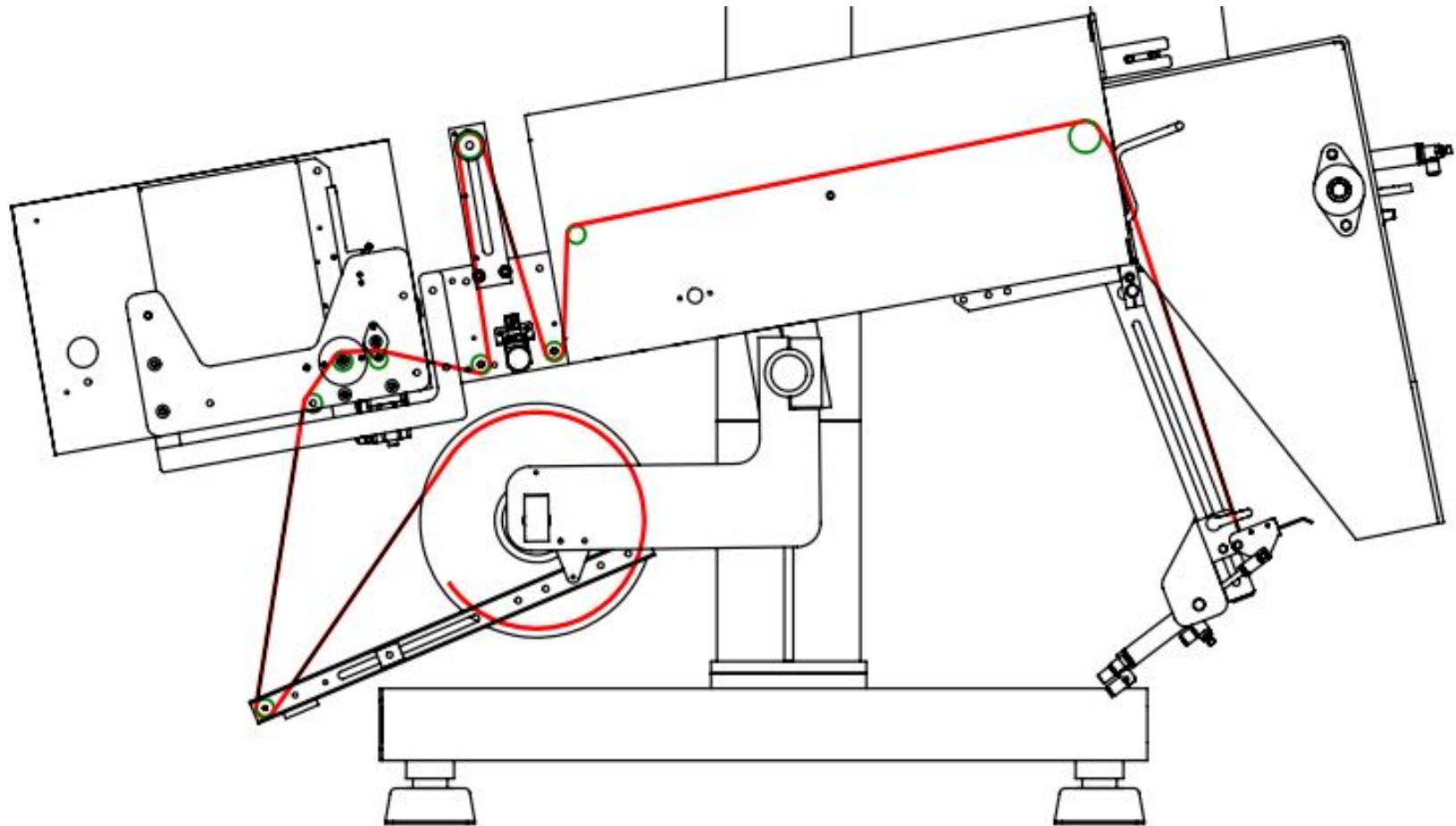

**T-1000-S14/US-9000 THREADING DIAGRAM**  
**SINGLE DANCER WITH NBO PRINTER**

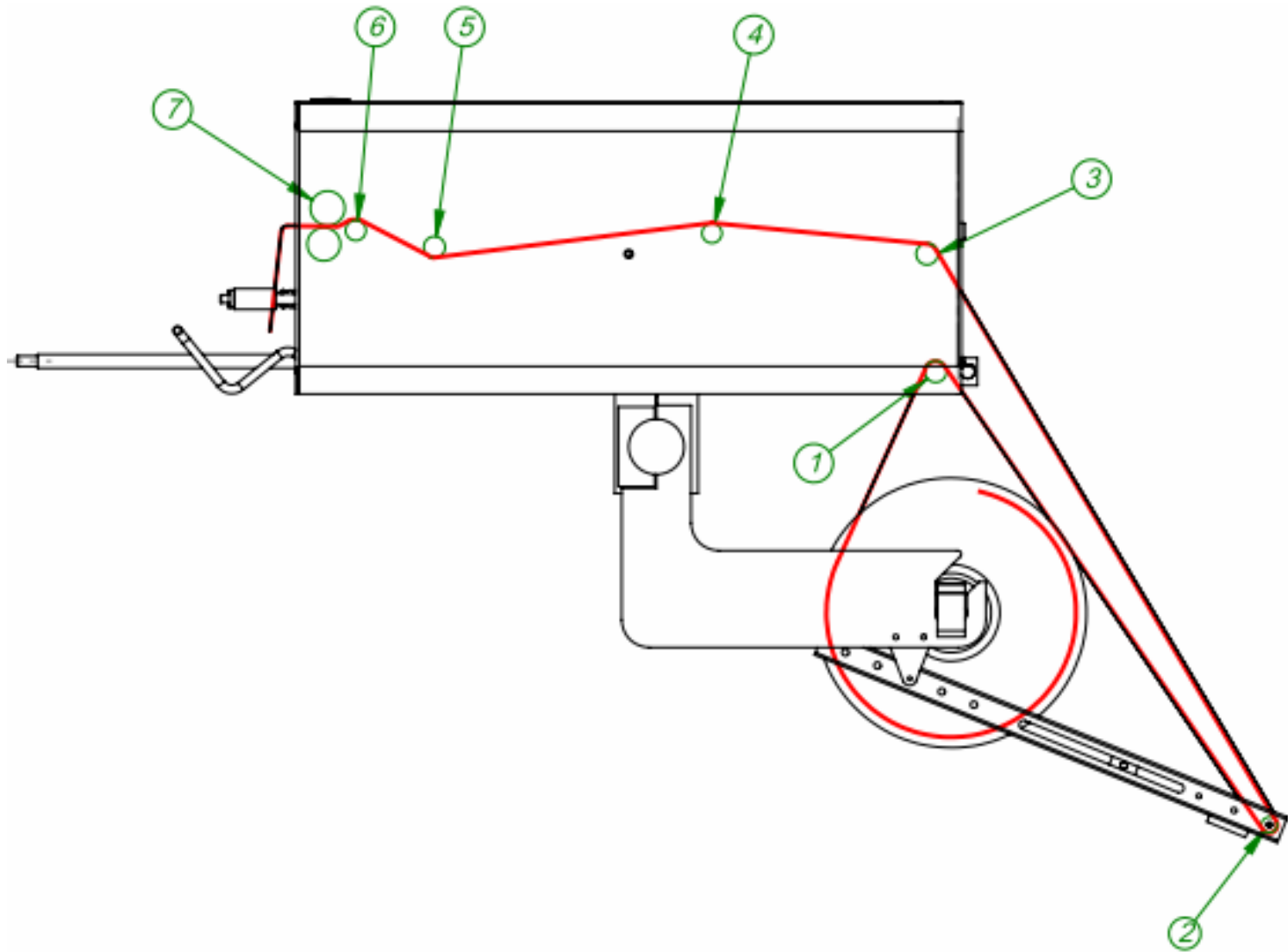

This page intentionally left blank.

# Chapter 3: Touch Screen Operation

---

Summary

Touch Screen Identification

Touch Screen Specifications

Overview

Introduction Screen

Main Menu

Operation Screen

Settings Screen

Piece Sample Screen

Options Menu

Counters

Job Save/Job Load Screen

Recipe Management

Auxiliary Options

Weight Log

History

Temperature Graph

Production Chart

Production Log

Alarm Tracking

Technical Assistance

Pass Code Setup Screen

PLC Info

Options Enable Screen

Solenoid Activation

Factory Settings

APPI Factory

Warning and Message Screens



## 3.1 Chapter Summary

This section describes the identification, operation and adjustments of the touch screen program.

## 3.2 Touch Screen Identification

FRONT PANEL:

1. **System** button
2. **F1** Displays the Help Screen
3. **F2** Increases brightness when **System** button is pressed
4. **F3** Resets screen to midpoint brightness when **System** button is pressed
5. **F4** Decreases brightness when **System** button is pressed
6. **F5** Displays Job Save / Recall screen

BACK PANEL:

1. RS-232 Communication port to PLC
2. Programming (For APPI use only)
3. Power Supply: Power terminal for touch screen operation.

## 3.3 Touch Screen Specifications / Features

<b>Power</b>	24 V DC (+/- 10%)
<b>Operating Environment</b>	0-50°C, 85% RH or less
<b>Display</b>	Color LCD
<b>Resolution (W x H)</b>	640 x 480 dots
<b>Display Area</b>	289 x 216 mm (10.4")
<b>Backlight</b>	CCFL
<b>PLC Connection</b>	RS232

## 3.4 Touch Screen Contrast Adjustment

The contrast of the LCD may be adjusted if the screen is difficult to read. To adjust the contrast press the **System** button located to the right side of the active touch screen area. Then press the **F2** button to increase brightness and the **F4** button to decrease brightness. Pressing **F3** will return the screen to midpoint brightness.

## 3.5 Touch Screen Program Overview

The touch screen program is a user-friendly, menu-driven setup and operation program. Pop-up windows are incorporated for quick and easy setting adjustments. Each time a setting is changed, the settings are saved so that if power is lost, the “job” will be recalled automatically without the need for reprogramming. A general color scheme has been used for consistency with operation:

- **Blue:** Background color used for text information. No “buttons” or functions are blue.
- **Green:** Used for buttons that change settings. Pressing a green button may display a pop-up window or turn a function on/off.
- **Red:** Indicates that a function is off or stopped. Pressing a red button may turn a function on.
- **Yellow:** Used for menu buttons. Pressing a menu button displays another screen and allows for movement throughout the entire program.

Most screens in the combined T-1000-S14/US-9000 program are divided into two sections. The left side of the screen contains controls and settings that affect the operation of the T-1000-S14. The right side of the screen contains controls and settings that affect the operation of the US-9000.

### 3.6 Introduction Screen

When the combined T-1000-S14/US-9000 system is turned on, an Introduction screen is displayed. The Introduction screen is a welcome screen, and it contains a button that will take the operator to the Operation screen. See Figure 3-1.



### 3.7 Main Menu

The Main Menu is initially accessed from the Operation Screen. The Main Menu screen allows the operator to quickly navigate to other areas in the program.

The yellow buttons located at the bottom

of the Main Menu screen are menu command buttons. Pressing a menu command button changes the screen currently displayed on the touch screen. To access another screen, simply press the corresponding menu command button. Menu command buttons appear throughout the touch screen program and are normally located at the bottom of the screen. See Figure 3-2.

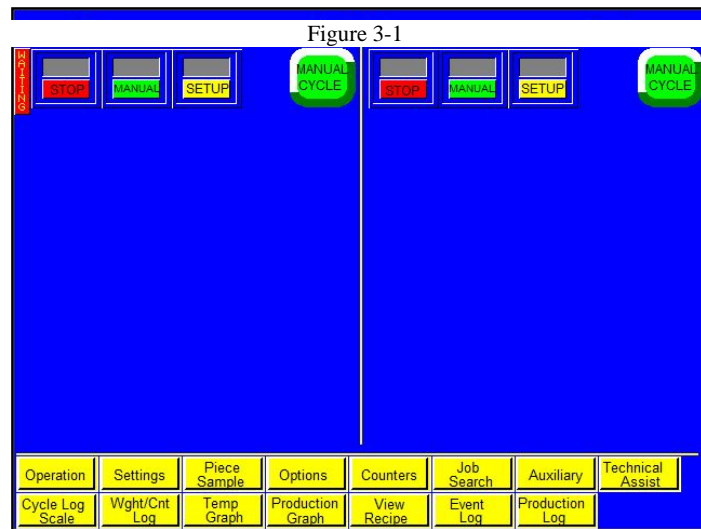

### 3.8 Bagger Operation Screen

The Bagger Operation screen is provided to function with the pass code protection function of the machine. If the pass code function is enabled, the touch screen will default to the Operation screen after a preset amount of time has elapsed. This function prevents unauthorized operators from making setting changes that could affect the operation or performance of the unit.

Since no settings are displayed on the Operation screen, the operator cannot change settings without entering a pass code. See Figure 3-3.

Mode toggle buttons are located at the top of many screens:

- **START / STOP:** This button initiates and halts the operation of the bagger. Toggle this button to START to begin operation.

Figure 3-2

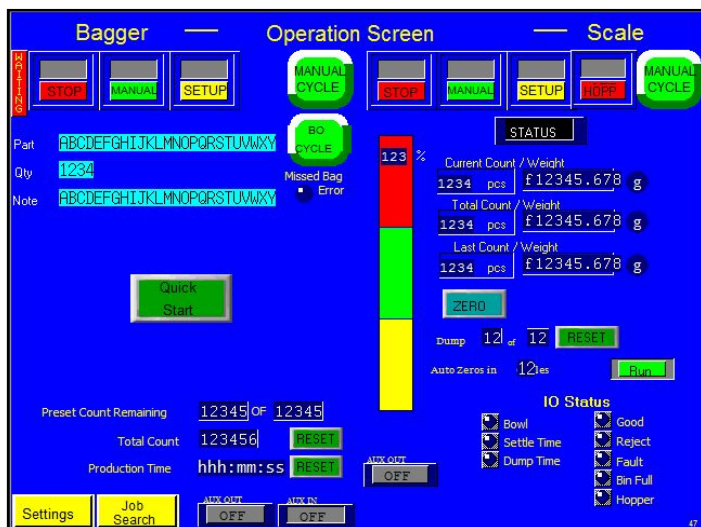

Figure 3-3

Toggle this button to STOP to stop operation.

- **M**  
**ANL / AUTO:** This button can be toggled to enter the machine into either Automatic or Manual mode. Automatic mode allows the machine to cycle automatically. Manual mode requires the operator to press the **Manual Cycle** button or foot switch to cycle the machine.
- **R**  
**UN / SETUP:** This button can be toggled to enter the machine into either Run or Setup mode. Toggle this button to SETUP to stop counters, production timers and auxiliary signals so the equipment can be operated independently. Setup mode deactivates functions and allows the machine to cycle when the heater bar is not up to temperature. Toggle this button to RUN to allow continuous operation.

**Ready / Waiting LED:** This LED displays “Ready” when the heater bar has reached the temperature set point. If “Ready” is displayed in the top left corner of the screen, the T-1000-S14 is ready for full operation. “Waiting” is displayed when the machine is not at temperature. If “Waiting” is displayed, operation will be paused unless the machine is in Setup mode.

The **BO Cycle** button allows the operator to test cycle the Bag Opening Device alone, without initiating other equipment or the T-1000-S14 seal operation.

Pressing the **Quick Start** button turns both the bagger and the scale to Automatic mode and Run mode and resets the dump counter.

**Preset Count Remaining:** Displays the number of cycle operations left before the bagger will stop automatically. The Preset Count counts down from a preset number and stops the machine when the preset number of cycles is reached. To adjust the Preset Count, press the right box and enter a number using the numeric keypad. The left box will then count down from that preset number.

**Total Count:** Displays the total number of cycle operations. Press the **Reset** button to set this counter to zero.

**Production Time:** Displays the amount of time the machine has been turned on and operating. Press **Reset** to set this counter to zero.

*NOTE: For more information regarding the pass code function, refer to the Pass Code Setup section of this chapter.*

**Aux Out:** Displays the status of the bagger’s communication to the auxiliary equipment. When Aux Out displays READY, the bagger is ready to drop bagged product to the auxiliary equipment. When Aux Out displays HOLD, the bagger is still cycling. If Aux Out displays OFF, no auxiliary equipment is present.

**Aux In:** Displays the status of the infeed auxiliary equipment’s communication to the bagger. When Aux In displays READY, the auxiliary equipment is ready to receive product. When Aux In displays HOLD, the auxiliary equipment is still cycling. Aux In displays OFF when no auxiliary equipment is present.

### 3.9 Scale Operation Screen

The Scale Operation screen allows the operator to monitor the operation of the scale, begin operation and stop the system. See Figure 3-3. Mode toggle buttons are located at the top of most screens in the touch screen program:

**START / STOP:** This button initiates and halts the operation of the scale. Toggle this button to START to begin operation. Toggle this button to STOP to stop operation.

**MANL / AUTO:** This button can be toggled to Automatic mode or Manual mode. Automatic mode allows the scale to cycle automatically when the weight is within the acceptable range. Manual mode requires the operator to press the **Manual Cycle** button to cycle the scale.

**RUN / SETUP:** If this button is toggled to **RUN**, auxiliary communication with the bagger turns on and the scale cycles automatically. If this button is toggled to **SETUP**, the scale will only operate if the **Manual Cycle** button or foot switch is pressed. When in Setup mode, counters, production timers and auxiliary signals are stopped so that the equipment can be operated independently. If setting up the scale, the Setup position is recommended.

**HOPPER ON / OFF:** If the machine is equipped with a hopper or hopper/conveyor system, this toggle button must be in the green ON position. To turn the hopper OFF, toggle this button to the red OFF position.

**Manual Cycle button:** Press this button to manually cycle the scale. If the final weight has been reached, the unit should cycle. Before running the scale in a system, the scale should be cycled several times as a stand-alone unit to test for parts flow and weight accuracy. The **Manual Cycle** button can be pressed any time during the sequence. When the scale reaches the final weight, the scale will automatically cycle and the weighing process will begin again.

**Status Display:** When the scale is within the zero range, the Status display will display “STATUS,” which indicates that the scale is idle. If the scale is over the zero range but under the acceptable weight range, “UNDER” will be displayed. If the scale is in the acceptable weight range, then “ACCEPT” will be displayed. If the scale has exceeded the acceptable weight range, then “OVER” will be displayed.

**Current Count / Weight:** Displays the weight or count of the product on the scale. If there is no product on the scale and the weight or count is not zero, press the **Zero** button to zero the scale.

**Total Count / Weight:** Displays the total amount of product cycled through the scale.

**Last Count / Weight:** Displays the count and weight of the previous batch of product.

**Dump:** Displays the remaining number of product dumps out of a preset, total value before the bagger seals the bag. If the desired bag count or weight cannot be achieved by dumping one full batch of parts, multiple product dumps are required. Press the **Reset** button to zero this value. This value can be adjusted on the Scale Settings screen.

**Auto Zero:** Displays the preset number of cycles during which the scale can drift from zero before the scale automatically zeros.

A bar graph is provided in the middle of the screen to illustrate the status of the scale. This graph shows the percentage of parts in the scale compared to the preset value. Input and Output (I/O) LEDs are provided at the bottom of the screen to notify the operator of various operation conditions, such as a rejected part or fault condition.

**Aux Out:** Displays the status of the bagger’s communication to the auxiliary equipment. When Aux Out displays READY, the bagger is ready to drop bagged product to the auxiliary equipment. When Aux Out displays HOLD, the bagger is still cycling. If Aux Out displays OFF, no auxiliary equipment is present.

### 3.10 Bagger Settings Screen

The Bagger Settings screen allows the operator to access, view and adjust the basic machine settings. These settings include Fill Time, Air Pulse, Seal Point, Seal Time, Reverse, Blow Off, Index Speed and Seal Temperature. Bag size, thickness and product characteristics affect these settings. See Figure 3-4. Once set, the operator may save the bagger settings, along with the options settings and auxiliary settings, for later recall. This screen also displays the current, last and average bag length.

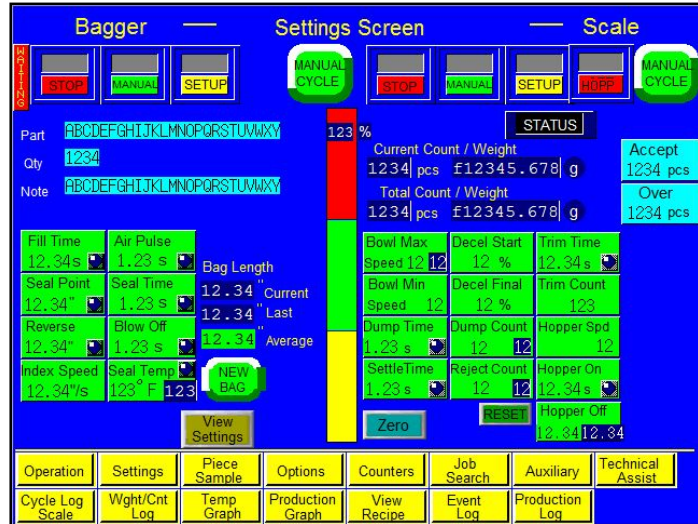

Figure 3-4

All settings will be entered numerically on a keypad. To adjust any value on this screen, press the green button of the setting you wish to change (i.e. **Reverse**) and then enter the desired value on the numeric keypad. Press the **ENT** button to accept the setting change. If a setting is entered incorrectly, press the **CLR** button and enter the correct value. After changing a setting, test cycle the bagger several times to ensure the setting adjustment produces the desired results. Adjust the settings until bags are trimming consistently.

Most entries and adjustments of machine operation settings will occur on the Settings screen. Whenever a new bag size or thickness is introduced, the T-1000-S14 must be set up properly in order to run the bags.

The **New Bag** button is used to start an internal program that calculates average bag length. This information is required so that if a perforation is not detected, the bag will still stop in the correct seal position. Press the **New Bag** button if bags are not consistently stopping at the correct seal point or after switching bag size. To manually adjust the average bag length, press the green numeric button under Average, enter a value on the numeric keypad and press the **ENT** button.

*NOTE: A Feed Error message will be displayed if the perforation is not detected within the accepted bag length range. Once a Feed Error occurs, the bagger will restart to calculate bag length.*

*NOTE: The bag length information displayed on this screen may not exactly match the bag length due to mechanical tolerances in the equipment (i.e. roller diameter fluctuations).*

Press the **View Settings** button to access the View Settings screen, which displays the bag, factory, option and part settings for a specific job and allows the operator to save these settings for future use. Refer to the Job Save/Job Load section of this chapter for more information.

#### A. Fill Time

Fill Time is the amount of time, in seconds, auxiliary infeed equipment or an operator has to load product into the bag before seal operation begins. Fill Time functions differently depending on which mode the T-1000-S14 is operating in: 1) Manual, 2) Automatic or 3) Auxiliary.

- 1) In **Manual** mode with no accumulating funnel, Fill Time delays operation from starting. When the T-1000-S14 is equipped with an accumulating funnel, Fill Time is the amount of time before the bagger begins to seal the bag after the accumulating funnel door has closed.

- 2) In **Automatic** mode with no auxiliary equipment, Fill Time is the amount of time before the seal bar actuates after the bag is blown open. In Automatic mode, a foot switch or other actuator is not required.
- 3) In **Auxiliary** mode, Fill Time is the amount of time a product, automatically loaded into the bag by auxiliary equipment, has to be completely settled in the bag before the seal bar actuates.

A suggested setting for Fill Time is 0.3 seconds.

**CAUTION: To avoid physical harm, DO NOT cycle the equipment in Automatic or Auxiliary mode if the funnel, guards, or covers are removed or out of position. Since the seal bar actuates automatically, operators must keep fingers, hands, and other parts of the body away from the sealing mechanism and all other moving parts.**

## B. Air Pulse

Air Pulse is the amount of time, in seconds, that a burst of air will initially blow the bag open. Wider bags and heavier gauge bags require a longer burst of air to initially open the bag. Narrower and thinner gauge bags require less air to initially open the bag. Adjust the flow control valves located on the right lower side of the seal frame assembly to increase or decrease air through the air pulse tube or blower. To *increase* the volume of air from the air pulse tubes, turn the air pulse valve counterclockwise. Turn the valve clockwise to *decrease* the volume of air. A suggested setting for Air Pulse is 0.3 seconds.

*NOTE: The volume of air set should be the minimum amount and duration required to consistently open the bag.*

## C. Seal Point

Seal Point is the position of the seal, in inches, measured from the top perforation of the bag. Seal Point can be set to the desired or required location. The proper positioning of the seal on the bag varies due to bag size and product characteristics. Wider bags generally require greater sealing area than narrower bags. Additionally, bags packaged with bulky products require a greater sealing area than bags packaged with thinner products. A suggested setting for Seal Point is 1 inch.

## D. Seal Time

Seal Time is the amount of time, in seconds, the pressure (rubber) bar will remain touching the surface of the bag for proper sealing. Sometimes referred to as "dwell time," Seal Time is one of three critical components to obtain a strong seal. Other critical factors include Seal Temperature and Seal Pressure. A suggested setting for Seal Time is 0.3 seconds.

## E. Reverse

Reverse is the distance, in inches, the rollers will reverse the bag into the T-1000-S14, while the pressure bar grips the bag, in order to break the perforation between bags. For wider bags, the reverse distance may need to be increased. A suggested setting for Reverse is 1 inch.

## F. Blow Off

Blow Off is the amount of time, in seconds, that the blow off tube will release a burst of air to remove sealed bags from the machine. The blow off tube, located immediately below the seal bar, decreases the possibility of bags sticking to the PTFE. Increase the Blow Off time if bags are not falling from the machine. A suggested setting for Blow Off is 0.3 seconds.

## G. Index Speed

Index Speed (bag feeding speed) is the speed, in inches per second, at which bags will feed/index into position. Index Speed can be set to improve production. If bags are prematurely breaking at the perforation, reduce the Index Speed. For shorter bags, the speed can be significantly decreased (to

10"/sec, for example). For longer bags, the setting can be increased. A suggested setting for Index Speed is 15"/sec.

## H. Seal Temperature

Seal Temperature is the temperature the heater bar must reach before full operation can begin. When the power is on, the heater bar element receives electrical current. The PLC pulses electrical current to the heater bar element until the temperature setting is reached. Shorter pulses indicate that the machine is maintaining the temperature. The indicator light on the **Seal Temp** button illuminates while the element is receiving current. The longer the light is illuminating, the longer the “pulse” of current and the further away the machine is from the required temperature setting.

If the temperature of the heater bar is not within a preset range around the preset Seal Temperature, “Waiting” will be displayed on the top left screen. If “Waiting” is displayed on the top left corner of the screen, the T-1000-S14 can only be operated in Setup mode. When the heater bar is up to temperature, “Ready” will be displayed on the top left of the screen. If “Ready” is displayed in the top left corner of the screen, the T-1000-S14 is ready for full operation. A suggested setting for Seal Temperature is 333°.

*NOTE: After making adjustments, test the seal strength prior to beginning production. It is normal for the Seal Temperature indicator light to illuminate (pulse) during operation. As the actual temperature approaches the set temperature, the pulses will grow shorter and shorter. From a "cold" start, it takes approximately four minutes for the machine to reach the set temperature.*

### NOTE ON SEAL QUALITY:

Quality seals are achieved by making adjustments to Seal Time, Seal Temperature and Seal Point and by having the proper seal pressure. As an additional seal function, an adjustment of the Cool Time setting may also be required for heavy or bulky products. If too hot, the seal may separate when the pressure bar releases the bag after sealing. Cool Time is considered a factory setting and can be adjusted on the Bagger Factory Settings screen.

If, after making necessary adjustments, the seal quality remains insufficient, additional options may be purchased to enhance seal appearance, integrity or strength. See Chapter 1 for a description of available options such as the FS-10 Flat Seal Assembly, TS-10 Trim Seal Assembly, BD-10 Bag Deflator and LS-10 Load Shelf. Wider seal bars are also available to increase the consistency of seals.

*NOTE: Ensure regulator pressure is set to 80 PSI.*

## 3.11 Scale Settings Screen

The Scale Settings screen contains weight value settings used to control the operation of the scale. The current and total weight is also displayed on this screen.

There are two different settings screens in the touch screen program: one for the scale when it is in Count mode (See Figure 3-4) and one for the scale when it is in Weight mode (See Figure 3-5). In Weight mode, the Settings screen displays the weight of the product. In Count mode, the Settings screen displays the quantity of product. A toggle button on the Factory Settings screen allows for switching between these two modes.

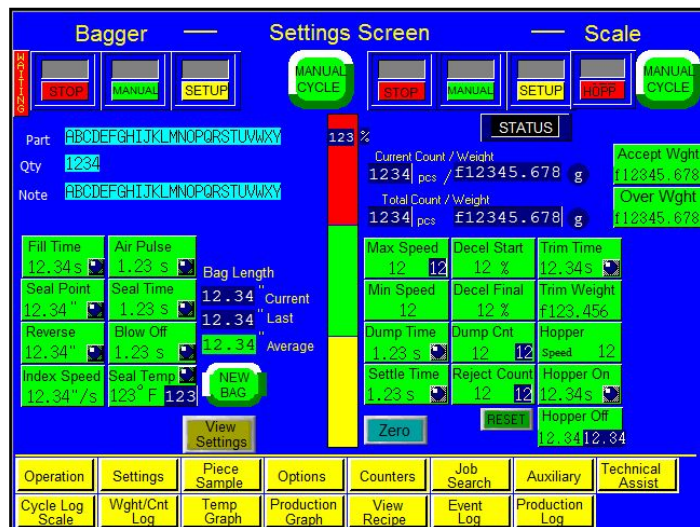

Figure 3-5

**Accept Weight/Count:** The Accept Weight/Count is the minimum weight or count needed to cycle the scale. To set this value, press the **Accept Wght/Accept** button, enter a value in the numeric keypad and press the **ENT** button.

**Over Weight/Count:** The Over Weight/Count is the maximum amount over the Accepted Weight/Count that a batch of product could be and still fall within the range of acceptance. To increase the range of acceptance, enter a value greater than the Accept Weight/Count for the Over Weight/Count. To set this value, press the **Over Wght/Over** button, enter a value into the numeric keypad and press the **ENT** button.

**Max Speed:** The maximum speed the bowl reaches during cycle operation to allow the majority of product to feed directly to the accumulator. To set this value, press the **Max Speed** button, enter a value into the numeric keypad and press the **ENT** button.

**Min Speed:** The minimum speed the bowl reaches during cycle operation to allow the last few parts in a batch to feed to the accumulator and ensure an accurate measurement; the speed of the bowl when the Deceleration Final setting reaches its preset percentage. To set this value, press the **Min Speed** button, enter a value into the numeric keypad and press the **ENT** button.

**Dump Time:** The length of time, in seconds, the scale dispenses parts into the bag. This time should be sufficient to consistently allow all parts to fully exit the scale. To set this value, press the **Dump Time** button, enter a value into the numeric keypad and press the **ENT** button. *NOTE: Increasing the dump time reduces production.*

**Settle Time:** The amount of time, in seconds, provided to allow product or the scale to become motionless before the scale locks the weight and cycles. By increasing the settle time, the accuracy of the scale increases, but the output/productivity decreases. To set this value, press the **Settle Time** button, enter a value into the numeric keypad and press the **ENT** button.

**Deceleration Start:** The percentage of the final count/weight that must be reached for the bowl to begin to transition to the minimum speed. To set this value, press the **Decel Start** button, enter a value into the numeric keypad and press the **ENT** button.

**Deceleration Final:** The percentage of the final/count weight that must be reached for the bowl to operate at minimum speed. To set this value, press the **Decel Final** button, enter a value into the numeric keypad and press the **ENT** button.

**Dump Count:** The number of product dumps required before the bagger seals the bag. If the desired bag count or weight cannot be achieved by dumping a single full tray of parts, multiple product dumps are required. To set this value, press the **Dump Count** button, enter a value into the numeric keypad and press the **ENT** button.

**Reject Count:** The maximum number of consecutive rejects the scale can accept before operation stops and the operator is prompted to make adjustments to the system. For example, if the Reject Count is set to four, and five consecutive measurements produce five consecutive rejects, an information/warning message will be displayed on the screen and operation will stop. To set this value, press the **Reject Count** button, enter a value into the numeric keypad and press the **ENT** button.

**Trim Time:** The amount of time, in seconds, the bowl turns back on for if the weight/count is under the Accept Weight/Count after the product has settled. The bowl will continue this procedure until the Accept Weight/Count is reached. To set this value, press the **Trim Time** button, enter a value into the numeric keypad and press the **ENT** button.



**Trim Count/Weight:** The amount of product that will cause the bowl to stop feeding and initiate the Settle Time. For example, if the Accept Count is set to 60 and the Trim Count is set to 56, the bowl will stop feeding when the count reaches 56. Because product may be dropping into the scale or because of the scale settle time, this function allows the bowl to stop before reaching the Accept Weight/Count and provides for a quantity/weight closer to the Accept Weight/Count. To set this value, press the **Trim Count/Trim Weight** button, enter a value into the numeric keypad and press the **ENT** button.

**Hopper Speed:** The speed of the hopper that feeds product to the bowl. This hopper runs at a constant speed in accordance with the Hopper On and Hopper Off time. To set this value, press the **Hopper Spd** button, enter a value into the numeric keypad and press the **ENT** button.

**Hopper On:** The amount of time, in seconds, the hopper turns on for to run more parts after the level sensor has indicated that there are no parts in the bowl. If parts are detected before the entire Hopper On time has passed, this setting is overridden and operation resumes as normal. To set this value, press the **Hopper On** button, enter a value into the numeric keypad and press the **ENT** button.

**Hopper Off:** The Hopper Off time occurs after the Bowl Feed On time has passed. Hopper Off is the amount of time, in seconds, the hopper waits to ensure parts are detected by the level sensor in the bowl. If parts are detected during the Hopper Off time, normal operation will resume. If parts are not detected during this time, the Hopper On procedure will begin again. To set this value, press the **Hopper Off** button, enter a value into the numeric keypad and press the **ENT** button.

### 3.12 Scale Piece Sample Screen

The average piece weight must be established in order for the scale to count accurately. See Figure 3-6.

*NOTE: Before performing this test, the scale should be empty, clean, in STOP, MANL, SETUP mode and at zero before proceeding.*

To run the test, first press the **Manual Cycle** button to clear the scale. Clean the scale tray, and then press the **Zero** button. Manually count a quantity sufficient to accurately determine the average piece weight. For smaller or lighter products, we recommend a higher quantity for the sample count. Drop product into the tray and then enter the quantity of product using the numeric keypad. Press the **ENT** button. Notice the One Piece weight value on the screen. Then press the **ENT** button again. If the One Piece value did not change, the One Piece weight or average piece weight has been established. As a final test, remove and add one piece at a time, ensuring the quantity changes accordingly.

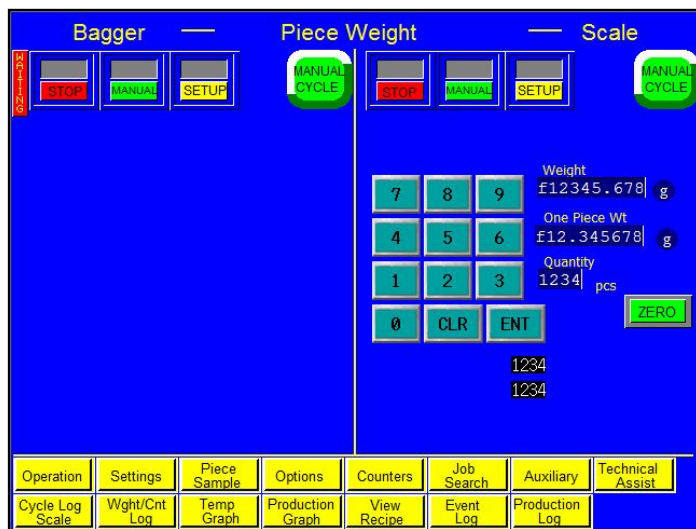

Figure 3-6

*NOTE: A higher batch count will establish a more accurate average piece weight.*

Due to “lot” weight variance, this count setup procedure should be conducted on a regular basis. We recommend performing the sampling procedure during the setup of every new part. If the piece quantity does not accurately display the number of pieces in the tray when one piece is removed, it may be due to varying piece weight. For very light pieces, the Quantity display may be constantly changing. If this occurs, the range may need to be increased.

Additionally, some parts may weigh less than the scale minimal increment. For example, five parts may need to be removed for the scale to decrement by a quantity of five. In this case, removing one part from a batch of 100 will still show 100 pieces in the scale until five pieces have been removed. Then the scale will display 95 pieces. When satisfied with the testing, press the **Operation** button.

### 3.13 Bagger Options

#### Menu

Several options can be added to the T-1000-S14 at the factory and then set up and adjusted from the Bagger Options Menu. If the option was not installed at the factory, then N/A (Not Available) will be displayed to the left of the option button. Otherwise, the area to the left of the option will display ON or OFF. See Figure 3-7.

*NOTE: If options are added in the field, a pass code is required to enable use of the option. Contact APPI for pass codes. Options that have been purchased separately must be installed by specialized maintenance personnel.*



Figure 3-7

To determine if a specific option has been activated, press the **Options** button from the Main Menu. The Bagger Options Menu will be displayed. Press the button of the option you wish to view (i.e. Load Shelf, Trim Seal). If an information screen is shown with an **Activate Option** button at the bottom of the screen, then the option has not been activated yet. Contact APPI Technical Support for information on how to activate the option. If the option has been activated, a settings or operation screen will be displayed after the option button is pressed.

*NOTE: If the option was purchased with the machine, the option will be activated at the factory. Otherwise, contact APPI Service Department for instructions on how to enable options.*

The following sections describe the settings for optional equipment. If your T-1000-S14 is not equipped with these options, please disregard these sections. Most of the listed options are not standard and must be purchased separately.

*NOTE: Due to specialized nature of some options or if your machine has custom programming, setting descriptions may not be included in this manual. Please contact APPI for special instructions.*

#### A. LS-10 Load Shelf

This option is used to support bagged product. It prevents the bag from prematurely tearing off at the perforation when product is inserted in the bag. The Load Shelf allows bagged product to drop onto the shelf, relieving the pressure on the bottom of the bag. See Figure 3-8.

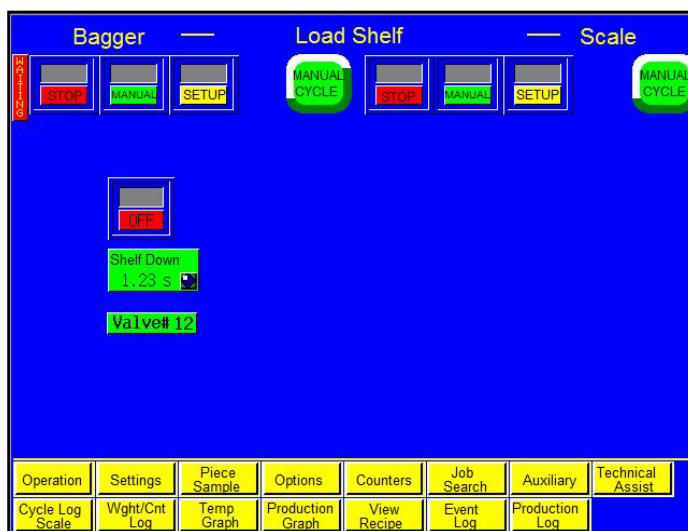

Figure 3-8

**ON / OFF button:** Press to toggle the Load Shelf on and off.

**Shelf Down:** The length of time the shelf is in the down position. To adjust this setting, press the **Shelf Down** button, enter a value into the numeric keypad and press the **ENT** button. Increase the time for longer bags.

*NOTE: Valve # X indicates the Valve Station number assigned to this option. Valve #0 indicates that no valve is assigned to this option. The option will not operate unless a Valve Station number greater than zero is assigned.*

## B. CS-10 Compartment Seal

This option seals the bag a second time to create two separate compartments within the same bag. This option is useful for separating different parts or protecting against damage caused from part contact. Both seal points can be adjusted by the operator to increase or decrease the size of each compartment. See Figure 3-9.

Press the **CS-10 ON/OFF** toggle button to turn this option on and off.

**Fill Time:** The amount of time, in seconds, auxiliary infeed equipment or an operator has to load product into the bag before seal operation begins. To adjust this setting, press the **Fill Time** button, enter a value on the numeric keypad and then press the **ENT** button.

**Seal Point:** The position of the first seal, in inches, measured from the top perforation of the bag. To set the first seal point, press the **Seal Point** button, enter the value on the numeric keypad, and press the **ENT** button.

**Seal 2:** The position of the second seal, in inches, measured from the top perforation of the bag. To set the second seal point, press the **Seal 2** button, enter the value on the numeric keypad, and press the **ENT** button.

**Reverse:** The distance, in inches, the rollers will reverse the bag into the T-1000-S14, while the pressure bar grips the bag, in order to break the perforation between bags. To adjust this setting, press the **Reverse** button, enter a value on the numeric keypad and then press the **ENT** button.

Set the first seal point by pressing the **Seal Point** button on the Compartment Seal screen and entering a value on the numeric keypad. Adjust the first seal point until the desired position is achieved. Then, turn the Compartment Seal option on by toggling the **ON / OFF** button to ON. Adjust the second seal point by pressing the **Seal 2** button and entering a value into the numeric keypad. Adjust the value of the second seal point until the desired position is achieved. Both seal points can be adjusted by the operator to increase or decrease the size of each compartment, but larger parts should be loaded first, in the larger, lower compartment of the bag.

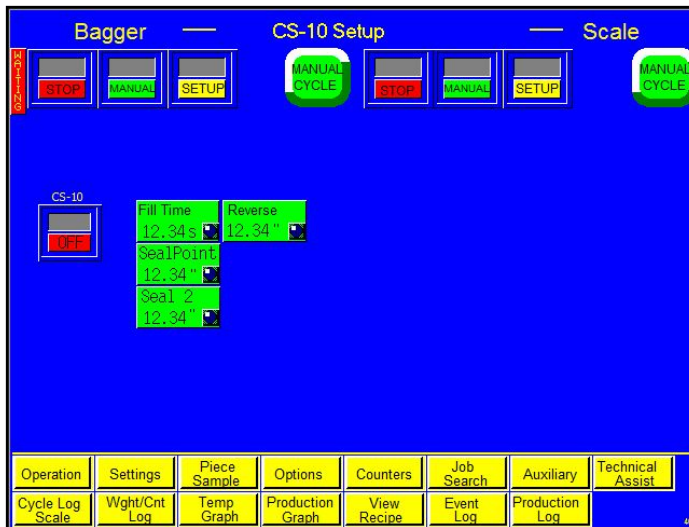

Figure 3-9

### C. FS-10 Flat Seal Assembly

This easy-to-attach option is used to decrease or eliminate wrinkles or folds in the bag when it is sealed. Fingers enter the bag immediately before sealing and flatten the seal portion of the bag by pulling the front and back layer of the bag together. This option is ideal for retail products, bulky products, air-tight packages and products that require a high integrity bag. See Figure 3-10.

On the Flat Seal Setup screen, toggle the **SETUP / AUTO** button to **SETUP**. SETUP mode allows the operator to easily make mechanical adjustments to the fingers along the front plate slots on the T-1000-S14. Once the mechanical adjustment is complete, change the toggle buttons to **ON** and **AUTO** for normal operation of the Flat Seal assembly. In Automatic mode, the fingers will automatically extend into the bag immediately before the pressure bar seals the bag.

Press the **BO-30** toggle button to turn the Bag Opening Device on and off.

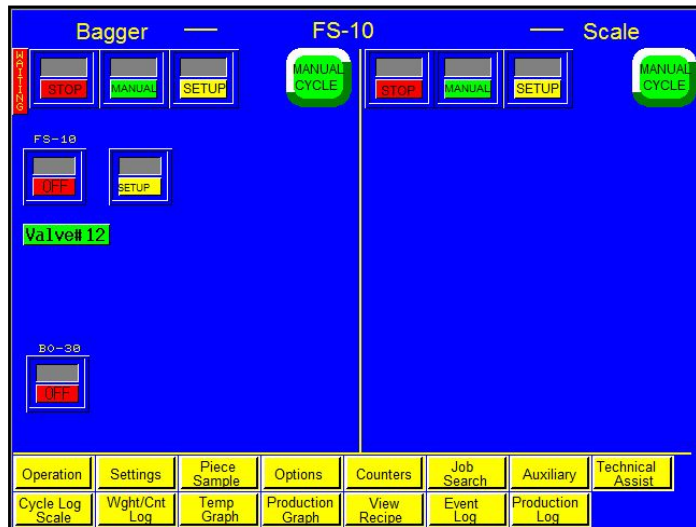

Figure 3-10

*NOTE: Valve # X indicates the Valve Station number assigned to this option. Valve #0 indicates that no valve is assigned to this option. The option will not operate unless a Valve Station number greater than zero is assigned.*

### D. TS-10 Trim Seal

The Trim Seal option removes excess film from the bag above the seal to enhance the appearance of packaged products. The Trim Seal option is ideal for retail products. See Figure 3-11.

*NOTE: To properly “trim off” excess film, the bag length may have to be increased to provide the required finished bag size. We recommend trimming at least 1.5” of film from the bag.*

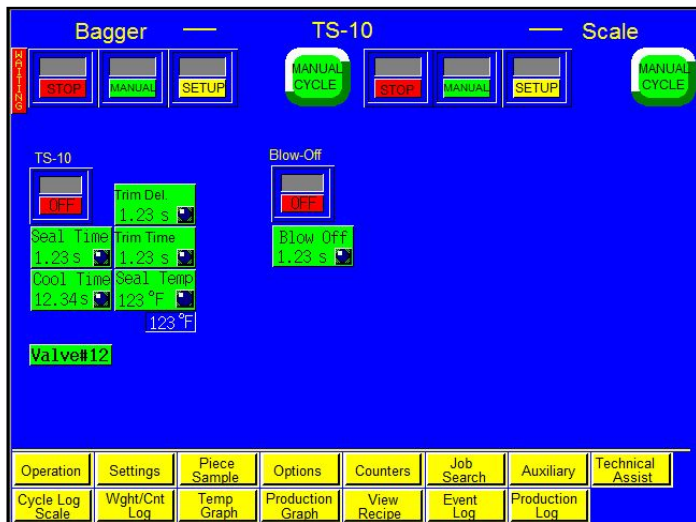

Figure 3-11

**TS-10 ON / OFF button:** Press to turn the Trim Seal option on and off.

**Seal Time:** The amount of time, in seconds, the pressure (rubber) bar will remain touching the surface of the bag for proper sealing. To adjust this setting, press the **Seal Time** button, enter a value on the numeric keypad and then press the **ENT** button.

**Cool Time:** The amount of time, in seconds, the pressure bar is released to ensure the seal is cool enough to be torn off after the pressure bar and heater bar have come in contact with the bag. To adjust this setting, press the **Cool Time** button, enter a value on the numeric keypad and then press the **ENT** button.

**Trim Delay:** The amount of time, in seconds, before the trimming assembly activates after the bag is sealed. To adjust this setting, press the **Trim Delay** button, enter a value on the numeric keypad and then press the **ENT** button.

**Trim Time:** The amount of time, in seconds, the trimming assembly removes excess film from the bag. To adjust this setting, press the **Trim Time** button, enter a value on the numeric keypad and then press the **ENT** button.

**Seal Temperature:** The temperature the heater bar must reach before operation can begin. To adjust this setting, press the **Seal Temp** button, enter a value on the numeric keypad and then press the **ENT** button.

**Blow Off:** The amount of time, in seconds, that the blow off tube will release a burst of air to remove sealed bags from the machine. To adjust this setting, press the **Blow Off** button, enter a value on the numeric keypad and then press the **ENT** button. Press the **Blow Off** toggle button to toggle this feature on and off.

Adjust these settings until bags are trimming consistently.

*NOTE: Operating the TS-10 option may cause production to decrease due to the additional time required for sealing and trimming. The normal trimming function increases maintenance required on the PTFE, heater bar and cylinders.*

*NOTE: Valve # X indicates the Valve Station number assigned to this option. Valve #0 indicates that no valve is assigned to this option. The option will not operate unless a Valve Station number greater than zero is assigned.*

## E. TS-10 Twin Seal

Special programming is available to seal the bag twice and increase the integrity of the bag. See Figure. The Twin Seal can be adjusted on the Bagger Factory Settings screen.

*NOTE: The Seal Point value on the Bagger Settings Screen may need decreased to allow space for two seals on the same bag. The weight of the product, special load shelves or other options, funneling and bag size will affect the operation of this option. Contact APPI Sales Support for more information.*

## F. ES-10 E-Stop Circuit

This option can be used to stop the cycle operation of the T-1000-S14 and possibly other auxiliary infeed or outfeed equipment. The E-Stop is useful for full systems that will run in an automatic operation. Multiple E-Stop buttons may be equipped.

If depressed, the E-Stop button will cut power to the drive motors, turn off air pressure and otherwise stop all moving components within the system. However, due to the wide range of equipment options, E-Stops may function differently from one system to another, depending on the components and safety requirements requested. When the E-



Figure 3-12

Stop is pressed, a message screen will be displayed. See Figure 3-12.

## G. LC-10 Light Curtain

This option is used as a safety device to avoid personal injury by ensuring that fingers or hands are not in the seal area during the cycle operation of the T-1000-S14. This option disables air power when the active area is obstructed. See Figure 3-13.

As an additional safety function, Automatic cycle mode is disabled when the Light Curtain option is activated. However, the foot switch input is not disabled when the Light Curtain option is turned on, so if the foot switch is pressed, the machine will cycle.

**Mode SAFE / AUTO button:** This button allows the operator to control how operation begins when the Light Curtain option is enabled. When this button is toggled to AUTO, the Light Curtain option can be used as a means of initiating the cycle operation of the bagger automatically after the Light Curtain sensing area is cleared. When this button is toggled to SAFE, cycle operation must be initiated manually using a foot switch or the **Manual Cycle** button.

**Message ON / OFF button:** If this button is toggled to ON, a message is displayed every time the Light Curtain area is blocked. The message tells operators to check for an obstruction. Remove the obstruction to continue operation. If this button is toggled to OFF, a message will not be displayed when the Light Curtain area is blocked. See Figure 3-14.

**Min Time:** The amount of time, in seconds, the Light Curtain must be blocked for before the T-1000-S14 can automatically cycle. To set Min Time, press the **Min Time** button, enter a value using the numeric keypad and then press the **ENT** button.

**Fill Time:** The amount of time, in seconds, before the machine cycles after the detection area is clear. For example, if the **Mode** toggle button is set to AUTO and the Fill Time is set to one second, the machine will cycle only after the operator has removed his or her hands and after one second has elapsed. To set Fill Time, press the **Fill Time** button, enter a value using the numeric keypad and then press the **ENT** button.

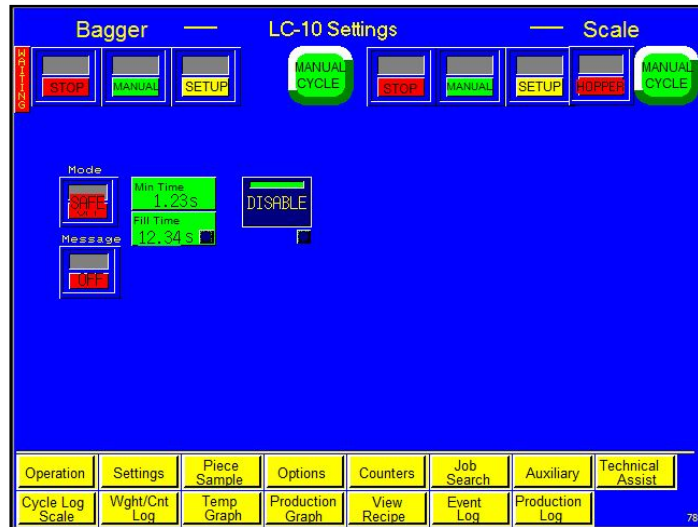

Figure 3-13



Figure 3-14

To enable the Light Curtain option, press the **Enable** button. Once enabled, the Light Curtain cannot be disabled without entering the correct pass code.

If a funnel or chute needs to be added that causes the Light Curtain area to be permanently blocked, and this funnel or chute also prevents the operator from reaching into the seal area, the Light Curtain can be deactivated. To deactivate the Light Curtain, press the **Disable** button on the Light Curtain settings screen. The Light Curtain Pass Code screen will be displayed. See Figure 3-15. A special pass code must be entered in order to deactivate this option. Contact the APPI Service Department for the pass code.

**CAUTION: To avoid personal injury, do not operate the T-1000-S14 when funnels are removed. APPI recommends either the Palm Buttons or Light Curtain to safeguard operators.**

**CAUTION: To avoid injury, do not reach under guards. This may defeat the safety feature of the LC-10 Light Curtain option. The Light Curtain only deactivates the motor and seal/pressure bar when enabled and when the Light Curtain beam is broken from above the seal bar. Reaching from underneath will place your hands or fingers in the seal area.**

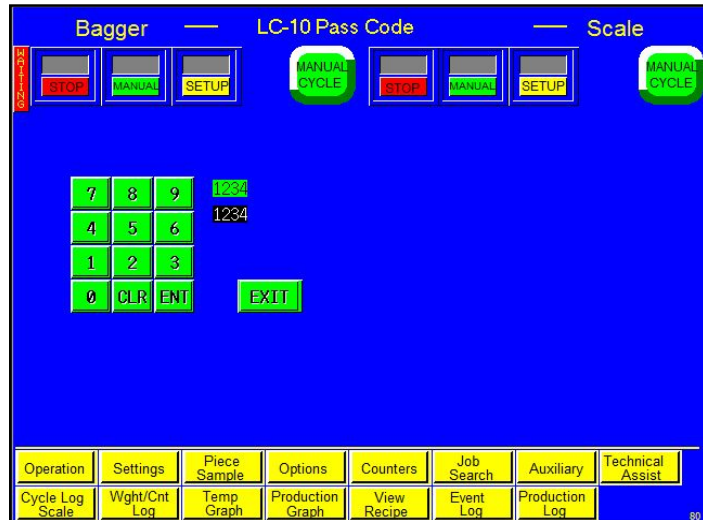

Figure 3-15

## H. AF-10 Accumulating Funnel

This photo optic, preset counting, special purpose funnel has several functions:

- 1) To accumulate a product before dropping the full contents of the accumulator into the bag.
- 2) To contain a product while the bagger is in cycle operation (sealing, tearing off and indexing a bag into position).
- 3) To insert the funnel into the bag and keep product away from the sealing portion of the bag.
- 4) To physically open the bag with a gate that enters the bag while product exits the funnel.

The Accumulating Funnel can provide increased production in both manual and automatic operations. In a manual operation, the operator can insert the product into the funnel without waiting for the bag to be in position and opened. When the bagger is ready to receive the product, the door at the bottom of the funnel will open, drop product and then shut, allowing the funnel to be loaded again. In an automatic operation, increased production can be achieved by allowing counters, fillers, scales and other infeed equipment to feed the funnel without regard for the status of the bagger.

The Accumulating Funnel can be operated in Open mode or Closed mode.

In Open mode, the door is closed only during the sealing operation. The door opens when the bag is in position and will remain open until the bag has been filled. The door will then close until the next bag is in position.

On the Accumulating Funnel (Open Mode) screen, several settings are provided to delay opening or to maintain the opening until product has passed through. See Figure 3-16.

- **Close Delay:** The amount of time, in seconds, before the funnel door closes after parts have settled in the bag.
- **Max Count:** Press the **Max Count** button to adjust the maximum number of parts that can be in the accumulator. Adjusting this number will help avoid overfilling. To disable this function, set the Max Count to zero.
- **Open Delay:** The amount of time, in seconds, before the funnel door opens after the preset amount of parts have settled in the accumulator.
- **Fill Time:** The amount of time, in seconds, before the bagger begins to seal the bag after the accumulating funnel door has closed.

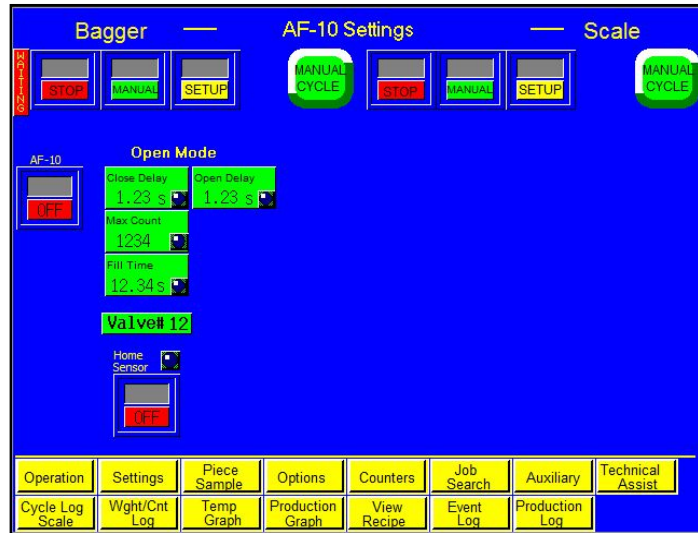

Figure 3-16

Press the **AF-10 ON / OFF** toggle button to turn this option on and off.

**Home Sensor:** The T-1000-S14 is equipped with a sensor that monitors the position of the accumulator door. If the sensor does not detect movement from the door during the appropriate times in the operation sequence, the home sensor LED will illuminate and an error message will be displayed. To turn the home sensor off and prevent the display of an error message, toggle the **Home Sensor** button to OFF. To activate the home sensor, toggle the button to ON.

In Closed mode, the door remains closed until the full batch is in the funnel. When the full batch is in the funnel, the funnel door will open until all product drops from the funnel.

On the Accumulating Funnel (Closed Mode) screen, several settings are provided to delay the opening or to maintain the opening until product has passed through. See Figure 3-17.

- **Open Delay:** The amount of time, in seconds, before the funnel door opens after the preset amount of parts have settled in the accumulator and the bag has blown open.
- **Open Time:** The amount of time, in seconds, the accumulator remains open to allow parts to completely exit the funnel.
- **Fill Time:** The amount of time, in seconds, before the bagger begins to seal the bag after the

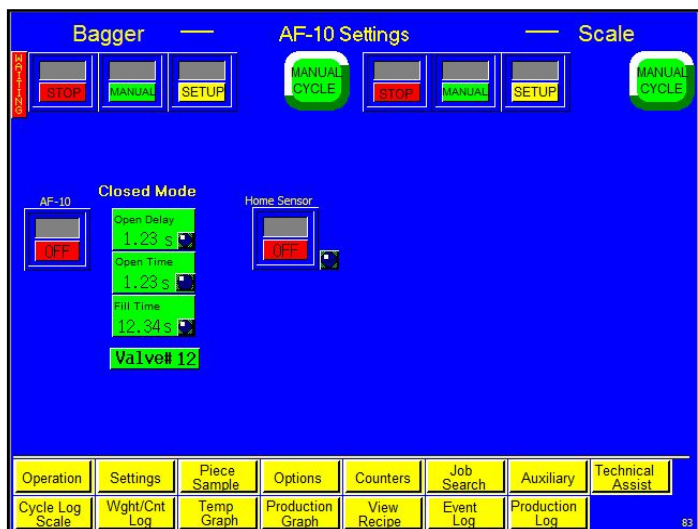

Figure 3-17



accumulating funnel door has closed.

Press the **AF-10 ON / OFF** toggle button to turn this option on and off.

**Door Home Sensor:** This button functions exactly like the **Home Sensor** toggle button on the Accumulating Funnel (Open Mode) screen.

*NOTE: Valve # X indicates the Valve Station number assigned to this option. Valve #0 indicates that no valve is assigned to this option. The option will not operate unless a Valve Station number greater than zero is assigned.*

## I. CF-10 Counting Funnel

This photo optic, preset counting option automatically cycles the bagger when a preset number of parts have fallen through the funnel. See Figure 3-18.

Photo optic eyes may vary depending on the product, so parts should be sent to APPI for testing to determine the correct components. Parts must be separated to be counted accurately through the eye. If two parts fall at the same time, they may be counted as one. Contact APPI Sales Support for additional options, programming or operations for automatic infeed equipment.



Figure 3-18

Press the **CF-10 ON / OFF** toggle button to turn the Counting Funnel on and off.

**Final / Current:** Final displays the total, preset count. Current displays the count the machine is processing. Press the green **Final / Current** button, enter a value on the numeric keypad and press the **ENT** button to adjust the final count. The Final LED will illuminate when the final count is reached.

**Min Size:** This setting affects how parts are counted and is used to filter scrap. Min Size can either be manually set by the operator or automatically set after an eye test is performed. If manually set, Min Size should be set to reflect the minimum size that can be counted as one part. For example, if the Min Size is set to 0.4, a part measured at 0.3 would not be counted, while a part measured at 0.5 would be counted as one part (assuming 0.5 falls below the Max Size setting). If automatically calculated, Min Size is 80% of the Min measurement. To adjust Min Size manually, press the green **Min Size** button on the Counting Funnel screen, enter a value on the numeric keypad and press the **ENT** button.

**Max Size:** This setting affects how parts are counted and is used to count connected parts or parts falling through the eye together as two parts. Max Size can either be manually set by the operator or automatically set after an eye test is performed. If manually set, Max Size should be set to reflect the maximum size that can be counted as one part. For example, if the Max Size is set to 0.8, a part measured at 0.6 would be counted as one part (assuming 0.6 is above the Min Size setting), while a part measured at 0.9 would be counted as two parts. If automatically calculated, Min Size is 160% of the Max measurement. To adjust Max Size manually, press the **Max Size** button, enter a value on the numeric keypad and press the **ENT** button. To adjust Max Size manually, press the green **Max Size** button on the Counting Funnel screen, enter a value on the numeric keypad and press the **ENT** button.

*NOTE: If Min Size is set too close to the actual minimum test value, some parts may not be counted, causing overcounts. If Max Size is set too close to actual maximum test value, one part may be counted as two, causing undercounts.*

**Count Timer:** The length of the time (time out time) the eye does not take a measurement while reading a part. Press the **Count Timer** button, enter a value on the numeric keypad, and press the **ENT** button to adjust the value.

**Message ON / OFF button:** If this function is turned on, a message will be displayed when the final count is reached. This message will inform the operator to stop loading until the bagger is ready to receive the next batch.

**Aux Out:** The **Aux Out** button will display either READY or HOLD (or OFF if there is no auxiliary equipment). When Aux Out displays READY, the bagger is ready to drop bagged parts. When Aux Out displays HOLD, the bagger is still cycling.

To manually open the funnel and drop product into a bag, press the **Open** button. Press the **Reset** button on the Eye Test screen to reset the sample values. When the Max Count has been reached, the Max Count LED will illuminate.

To ensure the accuracy of the count, an eye test must be performed. Press the **Eye Test** button on the Counting Funnel screen to display the Eye Test screen and perform an eye test. See Figure 3-19.

**Parts Length Test (Eye Test):** With the Counting Funnel option turned on, press the **Reset** button on the Eye Test screen. Toggle the **START / STOP** toggle button to STOP. Then, drop parts (samples) individually through the photo sensor / funnel. The Min and Max values at the bottom of the screen will change as parts are dropped through the eye. If parts will be fed automatically, parts should pass through the eye as they would if feeding automatically.

Press the **Accept** button if the Min / Max values do not change after dropping many sample parts. If the Min / Max values continue to change, continue dropping samples until the values do not change. Once the values remain consistent, press the **Accept** button and return to the Counting Funnel screen. Test the settings by dropping one part at a time, ensuring that each count is a value of one. If not counting correctly, return to the Eye Test screen or change the Min / Max Size settings manually. If the eye is blocked for an extended period of time (parts jam), the machine will stop and a message will be displayed. Press the **Reset** button on the Eye Test screen to reset the sample values.

**Min:** The smallest size recorded during a test. .

**Max:** The largest size recorded during a test.

**Time Out:** This setting is automatically calculated based on the “sample” parts values and the eye test results. Time Out displays the period of time the eye does not take a measurement while reading a part.

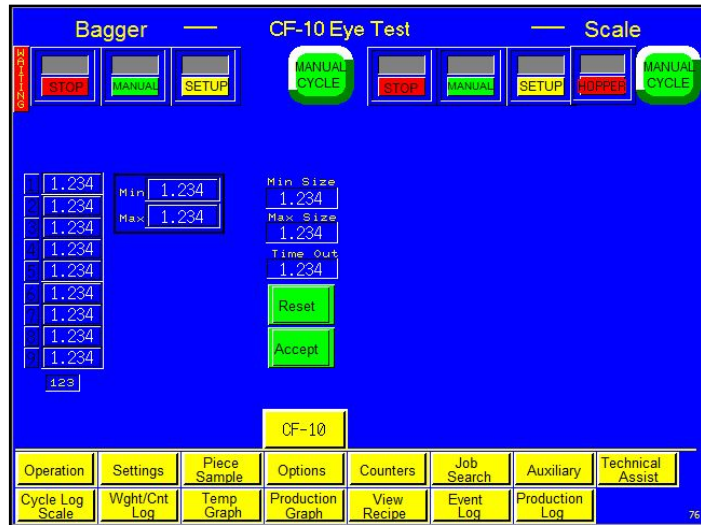

Figure 3-19

*NOTE: While the Eye Test screen only displays the last nine part readings, there is no limit to the number of parts that can be used and tested during an Eye Test.*

## J. DF-20 Part Diverter (Diverting Funnel)

This feature is used to count bags and divert them from the bagger for further packaging operations. See Figure 3-20.

**Final / Current:** Final displays the total, preset count. Current displays the count the machine is processing. Press the green **Final / Current** button, enter a value on the numeric keypad and press the **ENT** button to adjust the final count. The Final LED will illuminate when the final count is reached.

**Flip Delay:** The amount of time, in seconds, before the part diverter will flip after receiving a signal from the sensor.

**Min Size:** This setting affects how parts are counted and is used to filter scrap.

Min Size can either be manually set by the operator or automatically set after an eye test is performed. If manually set, Min Size should be set to reflect the minimum size that can be counted as one part. For example, if the Min Size is set to 0.4, a part measured at 0.3 would not be counted, while a part measured at 0.5 would be counted as one part (assuming 0.5 falls below the Max Size setting). If automatically calculated, Min Size is 80% of the Min measurement. To adjust Min Size manually, press the **Min Size** button, enter a value on the numeric keypad and press the **ENT** button.

**Max Size:** This setting affects how parts are counted and is used to count connected parts or parts falling through the eye together as two parts. Max Size can either be manually set by the operator or automatically set after an eye test is performed. If manually set, Max Size should be set to reflect the maximum size that can be counted as one part. For example, if the Max Size is set to 0.8, a part measured at 0.6 would be counted as one part (assuming 0.6 is above the Min Size setting), while a part measured at 0.9 would be counted as two parts. If automatically calculated, Max Size is 160% of the Max measurement. To adjust Max Size manually, press the **Max Size** button, enter a value on the numeric keypad and press the **ENT** button.

*NOTE: If Min Size is set too close to the actual minimum test value, some parts may not be counted, causing overcounts. If Max Size is set too close to actual maximum test value, one part may be counted as two, causing undercounts.*

**Count To:** The length of the time (time out time) the eye does not take a measurement while reading a part. Press the **Count To** button, enter a value on the numeric keypad, and press the **ENT** button to adjust the value.

**Eye / Count toggle button:** When toggled to **COUNT**, the diverter flips to divert bags after a preset quantity have been cycled. When toggled to **EYE**, the diverter flips and diverts every bag.

To ensure the accuracy of the count, an eye test must be performed. Press the **Eye Test** button to display the DF-20 Eye Test screen and perform an eye test. See Figure 3-21.

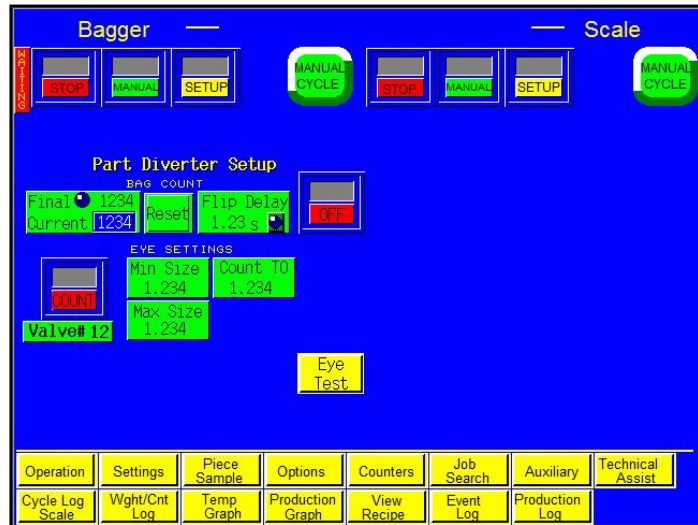

Figure 3-20

**Parts Length Test (Eye Test):** With the Part Diverter option turned on, press the **Reset** button on the Eye Test screen. Toggle the **START / STOP** toggle button to **STOP**. Then, drop parts (samples) individually through the photo sensor / funnel. The Min and Max values at the bottom of the screen will change as parts are dropped through the eye. If parts will be fed automatically, parts should pass through the eye as they would if feeding automatically.

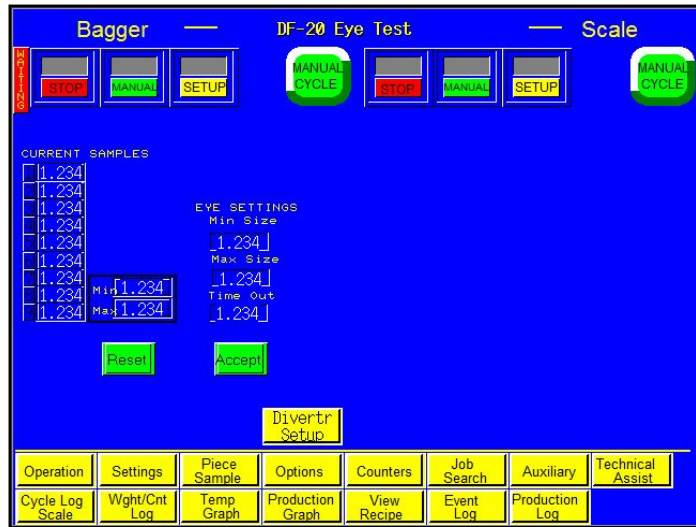

Figure 3-21

Press the **Accept** button if the Min / Max values do not change after dropping many sample parts. If the Min / Max values continue to change, continue dropping samples until the values do not change. Once the values remain consistent, press the **Accept** button and return to the Part Diverter screen. Test the settings by dropping one part at a time, ensuring that each count is a value of one. If not counting correctly, return to the Eye Test screen or change the Min / Max Size settings manually. If the eye is blocked for an extended period of time (parts jam), the machine will stop and a message will be displayed. Press the **Reset** button on the Eye Test screen to reset the sample values.

**Min:** The smallest size recorded during a test.

**Max:** The largest size recorded during a test.

**Time Out:** This setting is automatically calculated based on the “sample” parts values and the eye test results. Time Out displays the period of time the eye does not take a measurement while reading a part. Press the **Accept** button if the Min / Max values do not change after dropping many sample parts. If the Min / Max values continue to change, continue dropping samples until the values do not change. Once the values remain consistent, press the **Accept** button and return to the Counting Funnel screen.

*NOTE: While the Eye Test screen only displays the last nine part readings, there is no limit to the number of parts that can be used during an eye test.*

*NOTE: Valve # X indicates the Valve Station number assigned to this option. Valve #0 indicates that no valve is assigned to this option. The option will not operate unless a Valve Station number greater than zero is assigned.*

## K. BO-30 Bag Opening Device

This optional device enters the bag with one or more “fingers” and then pulls the bag open to a stop. The stop holds the bag open during loading and also validates that there is bag material present in the “gripper.” Air can also be shut off at this point. See Figure 3-22.

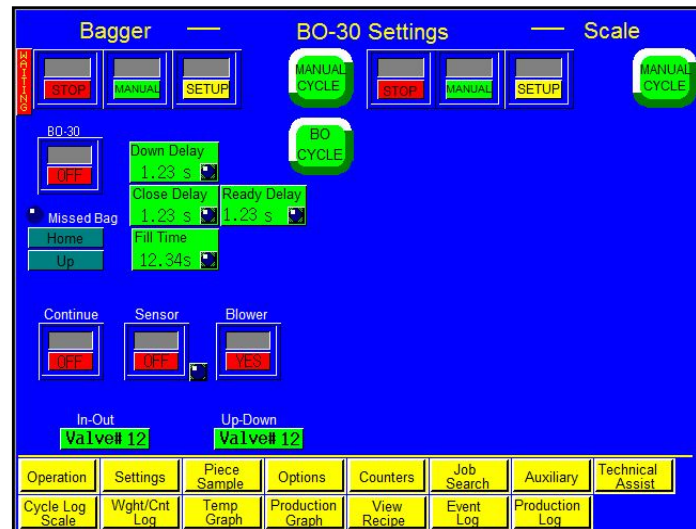

Figure 3-22

Press the **BO-30 ON / OFF** toggle button to turn this option on and off.

There are several settings on the Bag Opener screen that alter operation:

- **Down Delay:** The delay time, in seconds, before the fingers will attempt to enter the bag after the bag is initially blown open.
- **Close Delay:** The amount of time, in seconds, after the fingers have entered the bag before the fingers will pull the bag to the gripper point.
- **Ready Delay:** The amount of time, in seconds, it takes the fingers to cycle before the machine looks for an error.
- **Fill Time:** The amount of time, in seconds, auxiliary infeed equipment or an operator has to load product into the bag before seal operation begins.

*NOTE: It is very important that Ready Delay is set correctly, as the entire operation of the machine is affected by this setting. If Ready Delay is too short, the machine could drop the product before it confirms the bag opening. The bag will not be ready and an error will occur. If Ready Delay is too long, the machine will cycle slower and there will be a loss of production.*

**Continue ON / OFF toggle button:** The **Continue** toggle button can be turned ON to automatically reject an empty bag and continue operation after failed attempts to open the bag. If this option is OFF and an error occurs, an error message will be displayed and the machine will not continue to another bag.

**Sensor ON / OFF toggle:** The T-1000-S14 is equipped with a sensor that monitors the position of the bag opener fingers. If the sensor does not detect movement from the fingers during the appropriate times in the operation sequence, the home sensor LED will illuminate and an error message will be displayed. To turn the home sensor off and prevent the display of an error message, toggle the **Home Sensor** button to OFF. To activate the home sensor, toggle the button to ON.

**Blower YES / NO toggle button:** When this button is toggled to YES, air will be blown into the bag while the product is dropped. When this button is toggled to NO, the air will shut off after the bag is grabbed by the bag opener fingers.

**Missed Bag LED:** Indicates a Bag Opener Error. If the Continue option is on, the machine will move on to another bag and continue operation if this error occurs. If the Continue option is off, an error message will be displayed if this error occurs and operation will stop.

**Home / Away and Up / Down** display the operation of the fingers. When the fingers are withdrawn, Home and Down are displayed. When the fingers are out and the product is in the bag, Away and Up are displayed.

Press the **BO Cycle** button to test cycle the Bag Opening Device alone, without initiating other equipment or the T-1000-S14 seal operation.

*NOTE: Valve # X indicates the Valve Station number assigned to this option. Valve #0 indicates that no valve is assigned to this option. The option will not operate unless a Valve Station number greater than zero is assigned.*

## L. ST-10 Stack Light Option

The ST-10 Stack Light option consists of two or three LEDs designed to notify the operator of various conditions. The two LED option includes a green light and a red light. The green light indicates an operation condition and the red light indicates a stop/fault condition. The three LED option consists of the same red and green light used by the two LED option and a yellow light, which indicates a warning condition.

## M. MV-10 Seal Validation

Seal validation is provided by adding additional components to detect failures or out of range conditions for components that affect seal quality. These components are validated, and alarm outputs are provided with each component. The Seal Validation screen displays these components. See Figure 3-23.

To cause a good seal and to confirm that each component required to obtain the seal is in range, three validations have been added to the T-1000-S14:

1. **Seal Time:** Sensors were added to the seal bar to measure how long the seal bar is engaged to validate that the heater bar is extended within an acceptable time compared to the set Seal Time.
2. **Pressure:** A pressure sensor was added with an alarm output that alerts the operator when the pressure falls out of the set range
3. **Temperature:** A secondary controller was added with an alarm output that alerts the operator when the temperature falls out of the set range in the temperature controller.

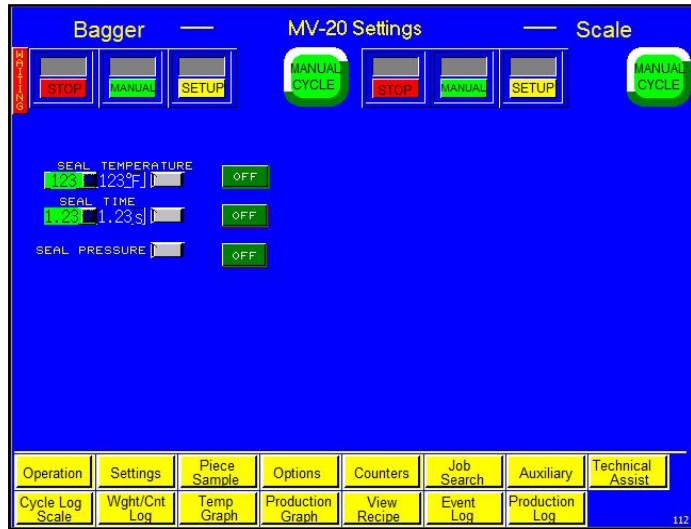

Figure 3-23

Typically, medical companies require seal validation as a secondary means to detect out of range conditions or to stop the operation when the condition exists. A message will be displayed if any of the three validation components are out of range. See Figure.

The pressure sensor may also be added to the T-1000-S14 to validate only pressure, without adding the other two components. For application requiring this validation only, the bagger will not operate unless the sensor provides an output indicating that the pressure is above a minimum allowable setting.

## N. BV-10 BarCode Reader Option

This option validates that a barcode is present and readable. See Figure 3-24.

If no barcode is detected, or if a barcode is not correctly formatted (as per software settings in the barcode verifier), then a NO READ message will be displayed. For each barcode successfully read, the status box will provide a GOOD message.

To turn this option on, toggle the BV-10 ON / OFF button to ON the BarCode Reader screen. Press the **Test** button to send a sync signal to the barcode verifier to turn on the scanner. In this mode, the verifier can be used to scan individual barcodes.

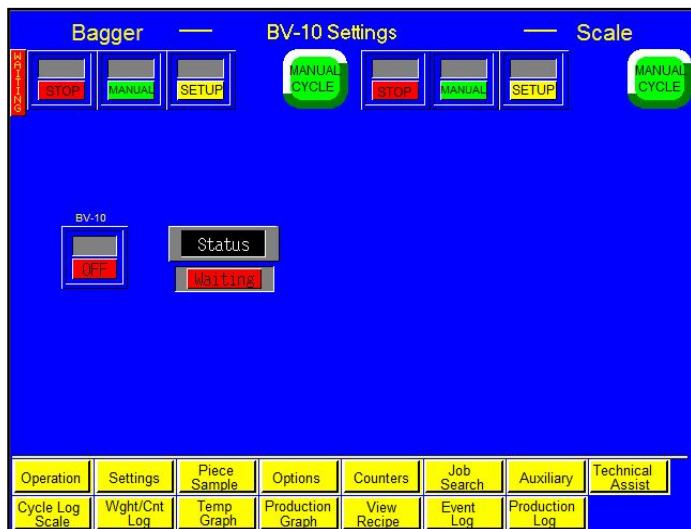

Figure 3-24

## O. Ti-1000 Inline Printer

The Thermal Inline Transfer Printer prints information, graphics images or bar codes directly onto the bag surface. Press the **Ti-1000** button on the Bagger Options Menu to display the Printer Setup screen. Press the **Ti-1000 ON / OFF** toggle button to turn the printer on and off. See Figure 3-25.

**Print Delay:** This setting causes the nip rollers to compress first, thus delaying the print head from lowering. This will ensure that the film is captured and ready to start feeding before the print head lowers. Increasing this delay time will cause loss of production. To change this setting, press the **Print Delay** button, enter a value on the numeric keypad and press the **ENT** button.

This screen also features a status display to indicate whether the Ti-1000 is printing or ready to print. An error indicator will illuminate if a printer error occurs.

## P. Ti-1000Z Printer

The Ti-1000Z Printer prints text, graphics and bar codes formatted in a separate software program directly to the surface of the film using a ribbon foil to transfer ink. The label formats are "downloaded" to the printer from a PC. See Figure 3-26. If you purchased the Ti-1000Z Printer, please refer to the Appendix for further information regarding the operation of this option.

## Q. NBO Printer

The T-1000-S14 Next Bag Out Printer / Bagger prints text, graphics and bar codes just before loading parts to ensure accurate labeling. If you purchased the NBO Printer, please refer to the Appendix for further information regarding the operation of this option.

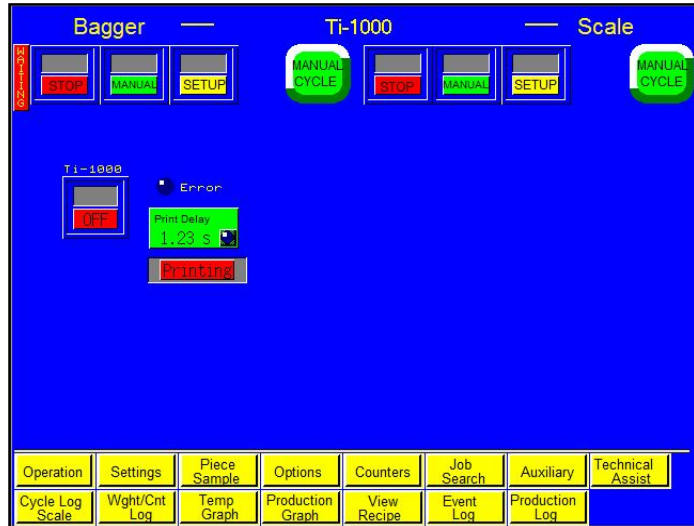

Figure 3-25

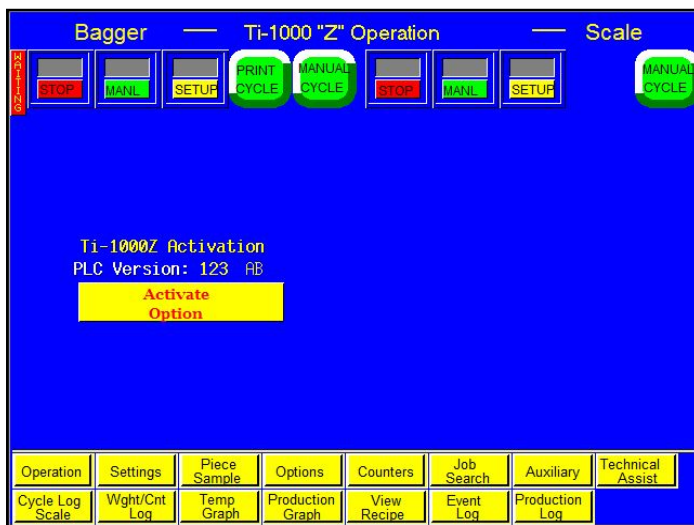

Figure 3-26

### 3.14 Counters Screen

The T-1000-S14/US-9000 is equipped with three internal counters as a standard feature. To access the Bagger Counters screen, press the **Counters** button on the Main Menu. See Figure 3-27.

**Continuous Strip Counter:** This counter allows the T-1000-S14 to seal bags in a strip without separating them at the perforation. For example, if this counter is set to a value of 10, the bagger will produce a strip of 10 connected bags. The bagger will then reverse to separate the eleventh bag. To enter a value for this counter, press the green **Set** button and enter a value using the numeric keypad. Then press the **ENT** button. To reset the counter, press the **Reset** button. To disable the counter, set it to zero.

*NOTE: If the bags should always remain in a continuous strip and never separate, set the Continuous Strip counter to a very large number or change the Reverse setting to zero on the Bagger Settings screen.*

**Preset Count:** This counter stops production after a preset number of cycle operations. When the preset count is reached, a message screen will be displayed and operation will stop. To enter a value for this counter, press the green **Set** button and enter a value using the numeric keypad. Then press the **ENT** button. To reset this counter, press the **Reset** button. To disable the counter, set it to zero.

**Total Count:** To track production, use the Total Count function to count the total number of machine cycles. This counter value is also displayed on the Operation screen. To reset this counter, press the **Reset** button.

### 3.15 Job Save / Job Load

To save settings for future use, press the **View Settings** button on the Bagger Settings screen. The View Settings screen will be displayed. See Figure 3-28.

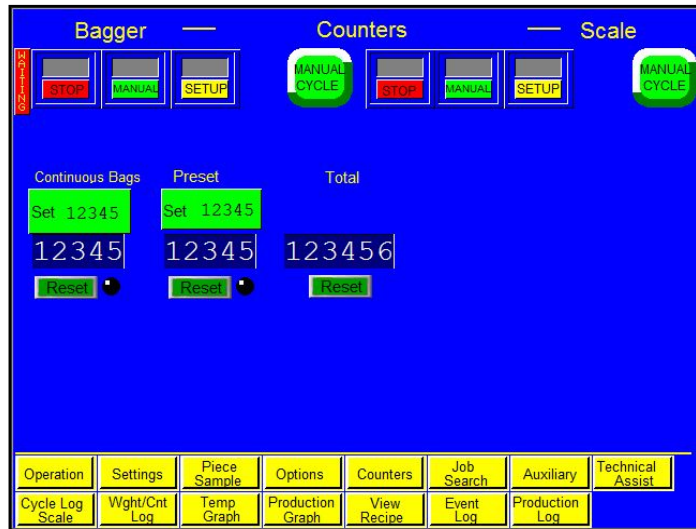

Figure 3-27

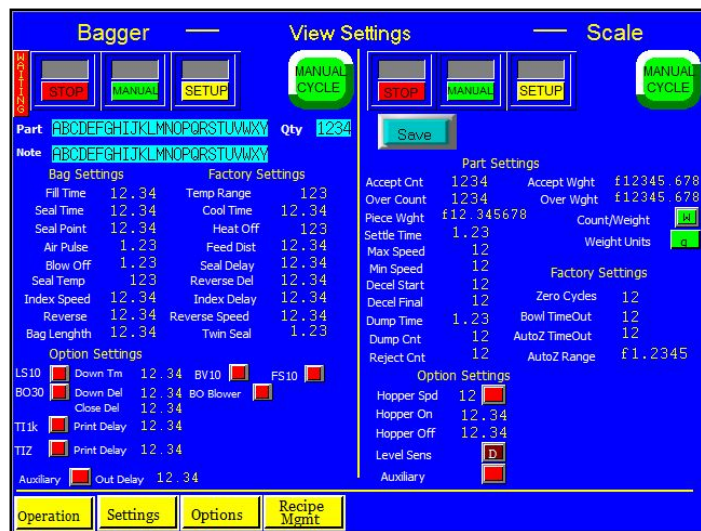

Figure 3-28

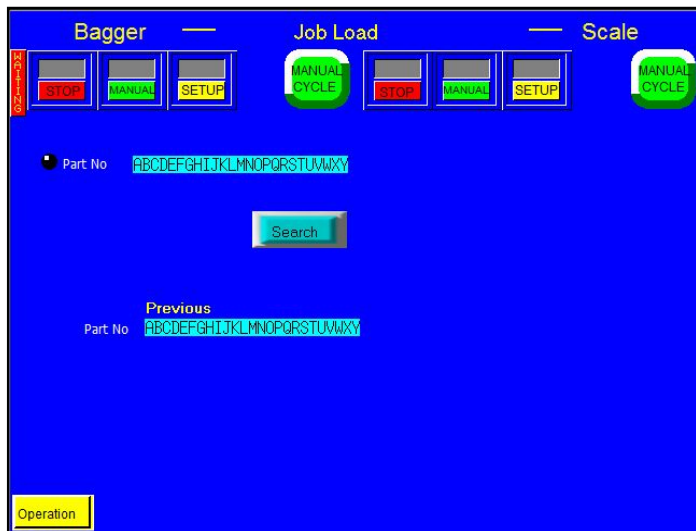

Figure 3-29



The View Settings screen displays the current bag, factory, part and options settings. To save these settings, press the blue **Part** box and enter a part number for the job. To make a note about the job, press the blue **Note** box and enter specific instructions for the job or a description of the product. Press the blue **Quantity (Qty)** box to enter the product quantity. Once this information has been entered, press the **Save** button to save the job.

To search for and load a specific recipe, press the **Job Search** button on the Main Menu. This will display the Job Load screen. See Figure 3-29. Enter the desired job's part number in the blue **Part No** box, and then press the **Search** button. On the following screen, press the desired part number with the correct quantity. See Figure 3-30. This will display the Job Recall screen. See Figure 3-31.

The Job Recall screen allows the operator to view the job settings and any notes that were made about the job. To load the displayed settings, press the **Load** button. The Scale Settings screen will be displayed after the **Load** button is pressed.

### 3.16 Recipe Management Screen

This screen displays a listing of all created recipes. See Figure 3-32. To access the Recipe Management screen, press the **View Recipe** button from the Main Menu.

Recipe settings can be viewed on the Recipe Management screen, but recipes cannot be loaded or saved on this screen. To scroll through the recipe listing, press the red up arrow or the blue down arrow. To view the settings for each recipe, press the yellow left and right arrows.

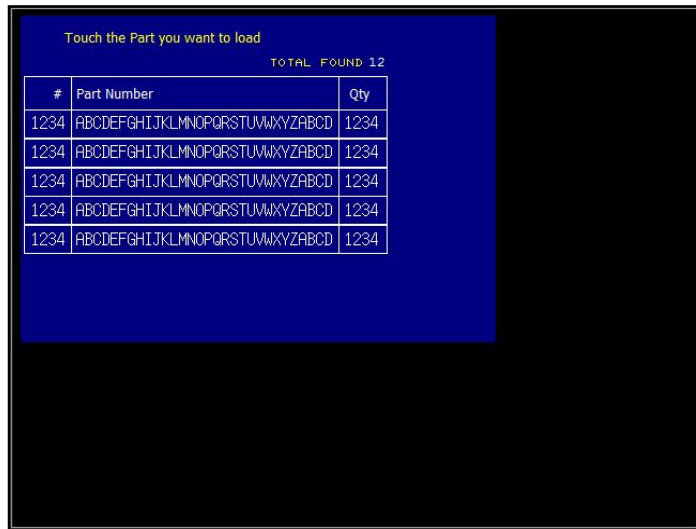

Figure 3-30

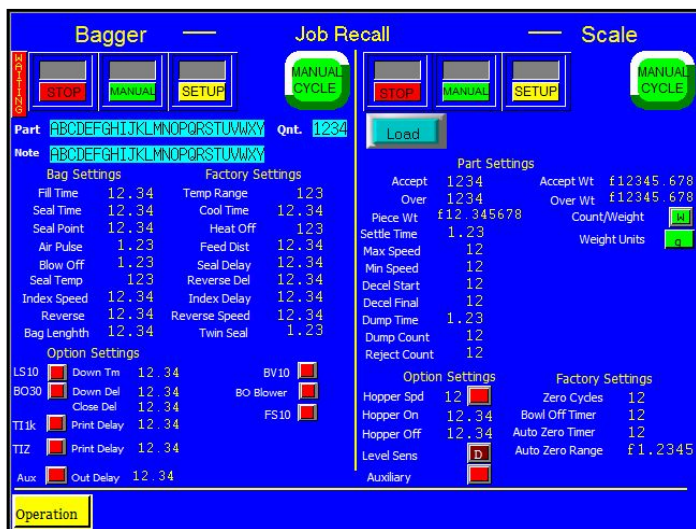

Figure 3-31



Figure 3-32

### 3.17 Bagger Auxiliary Options

The T-1000-S14 touch screen program is preprogrammed to accept most auxiliary equipment signals so that two or more pieces of equipment can “talk” to each other. Occasionally, reprogramming will be necessary to interface auxiliary infeed equipment that is not manufactured by APPI. Additional cabling may be required to transfer the signals between the T-1000-S14 and your existing equipment. See Figure 3-33.

Once the equipment is connected and both systems are running independently, toggle the T-1000-S14 **AUX** toggle button to the ON position to allow the bagger to operate with the scale.

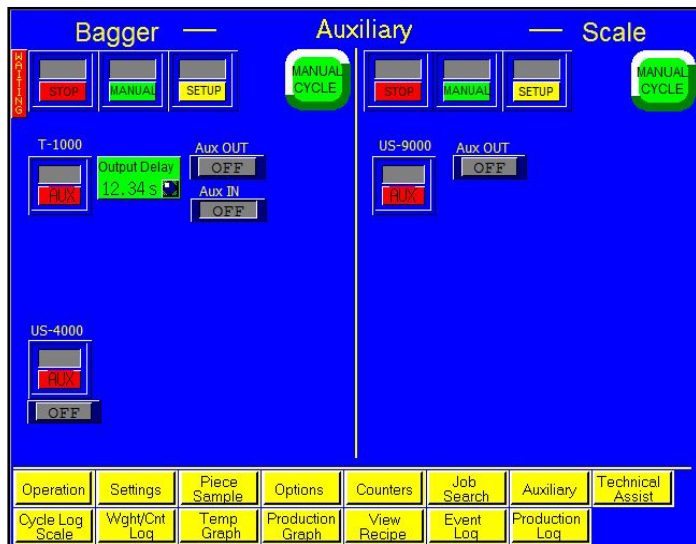

Figure 3-33

**Output Delay:** This setting controls the delay time between the cycling of the auxiliary infeed equipment (i.e. scale, counter, conveyor, other bagger) and the cycling of the bagger. Output Delay is the amount of time, in seconds, before the bagger seals the bag after the auxiliary infeed equipment has cycled and signaled to the bagger to seal. To adjust this setting, press the **Output Delay** Button, enter a value on the numeric keypad, and press the **ENT** button.

**Aux Out:** Displays the status of the bagger’s communication to the auxiliary equipment. When Aux Out displays **READY**, the bagger is ready to drop bagged product to the auxiliary equipment. When Aux Out displays **HOLD**, the bagger is still cycling. If Aux Out displays **OFF**, no auxiliary equipment is present.

**Aux In:** Displays the status of the infeed auxiliary equipment’s communication to the bagger. When Aux In displays **READY**, the auxiliary equipment is ready to receive product. When Aux In displays **HOLD**, the auxiliary equipment is still cycling. Aux In displays **OFF** when no auxiliary equipment is present.

**US-4000:** This toggle button turns on communication between the T-1000-S14/US-9000 system and the US-4000 Check Weigh Scale. If the T-1000-S14/US-9000 system is operating with the US-4000, toggle this button to the green, up position. If the system is not operating with the US-4000, toggle this button to the red, down position. The indicator directly below the toggle button displays the status of the US-4000. When the US-4000 indicator displays **READY**, the US-4000 is ready to receive product. When the indicator displays **HOLD**, the US-4000 is still cycling. If the indicator displays **OFF**, communication between the system and the US-4000 is disabled.

### 3.18 Scale Auxiliary Screen

This screen allows the operator to set up auxiliary communication between the scale and bagger. To allow the scale to operate with the bagger, toggle the **US-9000 AUX** toggle button to the ON position. See Figure 3-33.

**Aux Out:** Displays the status of the scale’s communication to the bagger. When Aux Out displays **READY**, the scale is ready to drop product to a bagger. When Aux Out displays **HOLD**, the scale is still cycling. If Aux Out displays **OFF**, no auxiliary equipment is present.

### 3.19 Scale Weight Log

The Weight Log displays the weight from each cycle of the machine. See Figure 3-34. The operator can use this screen to view past cycle weights, accept values and over values. Press the green reset button twice to reset all values on the screen to zero. Press the up and down arrows to scroll through the log. To access this screen, press the **Cycle Log Scale** button on the Main Menu.



Figure 3-34

### 3.20 Weight/Count History

The Weight/Count History screen keeps a record of all previous cycles. This screen allows the operator to keep an accurate account of all weights and counts. To access the Weight or Count History screen, press the **Wght/Cnt Log** button. See Figures 3-35 and 3-36.

Press the **Reset** button to reset all values on the screen to zero.

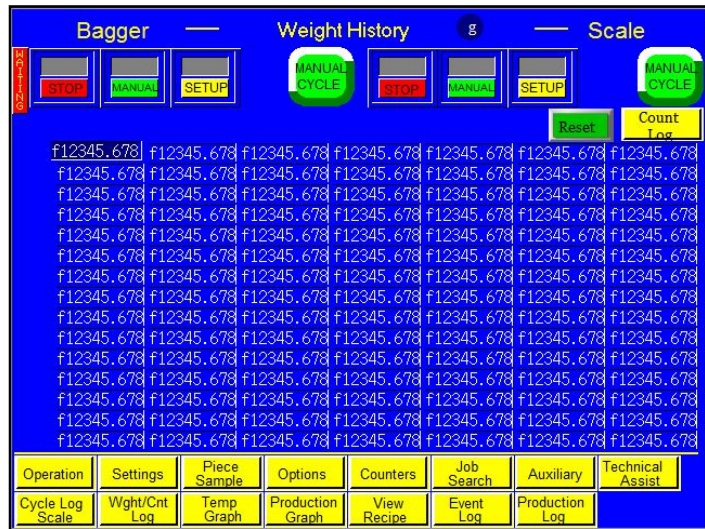

Figure 3-35

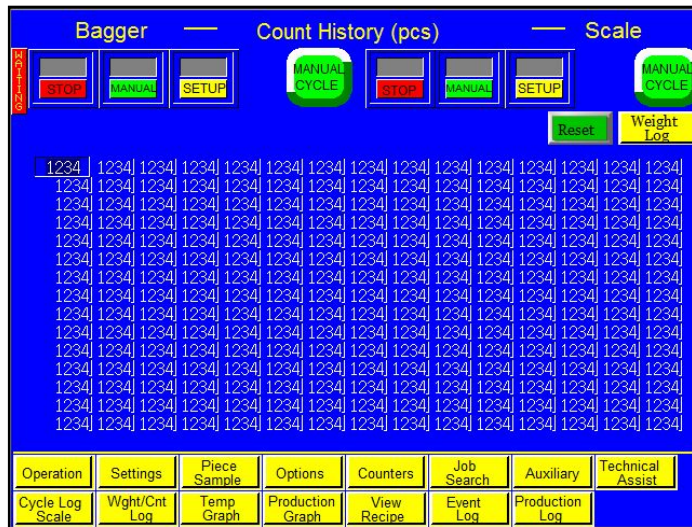

Figure 3-36

### 3.21 Temperature Graph

APPI provides a temperature graph to display the operating temperature during production. This information isolates the problem if bags are found to have weak seals by allowing the operator to review previous operating temperatures. See Figure 3-37.

The left arrow key is used to view prior operating temperatures and the right arrow key is used to view more recent temperatures. Press the **Reset** button to reset the graph.

The bottom graph serves as a detail graph and displays the most current temperature readings.

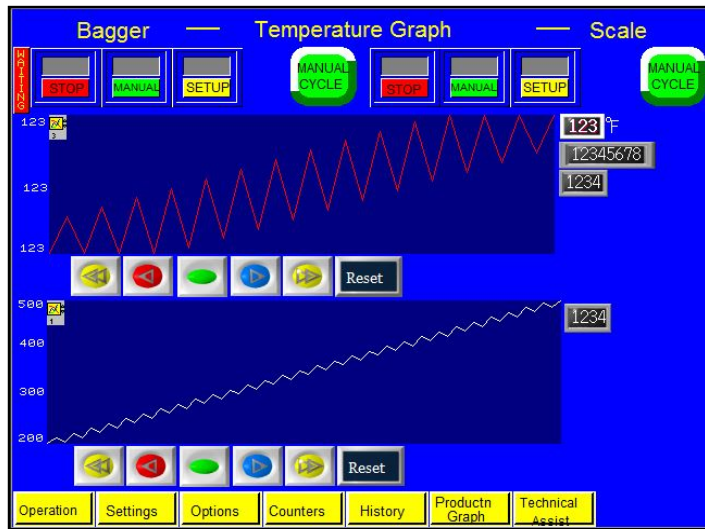

Figure 3-37

### 3.22 Bagger Production Chart

APPI provides a simple graph to chart production throughout the day. See Figure 3-38.

Press the left arrow key to scroll back one hour at a time and review past production. Press the right arrow key to check more recent production information.

Press the **Reset** button once to reset the production time and twice to reset the graph. Press the **Return** button to return to the previous screen.

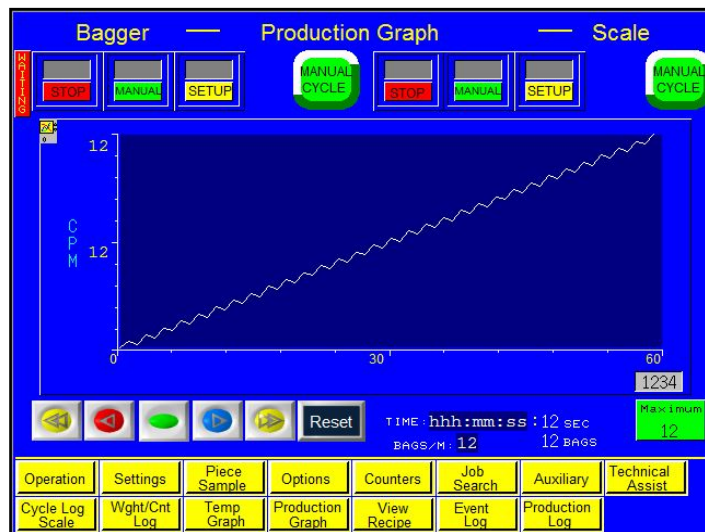

Figure 3-38

The Bagger Production Chart screen also displays the amount of bags indexed per minute and the production time.

### 3.23 Production Log

The Production Log screen displays the time and frequency of a particular operation. See Figure 3-39. It also provides access to the Operation Log and Alarm Data screens.

The colored bar at the bottom of the Operation Mode screen is color-coded to reflect the percentage of time the machine has been in the following modes: Full Operation, Aux Off, Manual Operation, Stop and Setup.

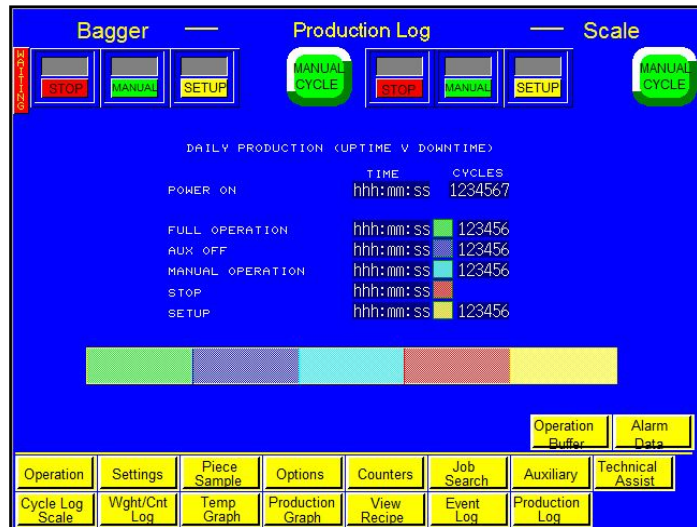

Figure 3-39

Press the **Operation Buffer** button to display the Operation Log screen and view the amount of time the machine has been in Power Up, Auto, Aux Off, Manual, Stop and Setup mode the number of machines cycles completed when the machine was in those modes. See Figure 3-40.

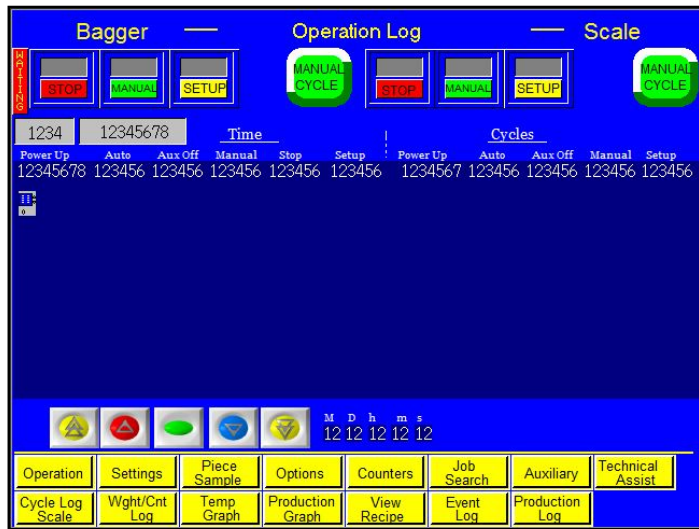

Figure 3-40

Press the **Alarm Data** button to view the Alarm Data screens. These screens keep track of how long and how often a particular warning message has been signaled. See Figure 3-41.

### 3.24 Alarm Tracking

The Alarm Tracking screen provides the start and reset time of a particular warning signal. See Figure 3-42. To access this screen, press the **Event Log** button on the Main Menu.



Figure 3-41



Figure 3-42

### 3.25 Technical Assistance

The Technical Assistance screen provides manufacturer information, factory settings adjustments, functions testing and troubleshooting. It also displays the program version for the PLC controller and touch screen. See Figure 3-43.

The screen is protected from access with a Level 1 pass code. The pass code is set by default (from the factory) to 1001. This code can and should be changed when the system is put into operation.

Several menu options are available from the Technical Assistance screen that will assist with troubleshooting the T-1000-S14/US-9000 and also change settings that affect the operation of the equipment.

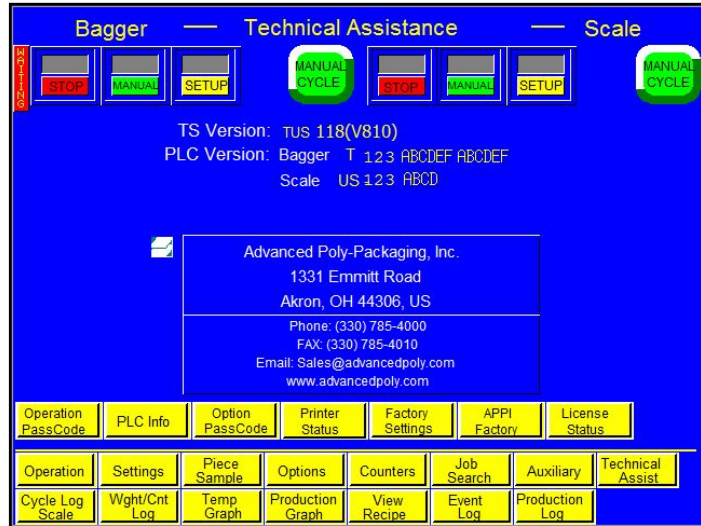

Figure 3-43

*NOTE: Technical assistance sections of the touch screen program should only be accessed by specialized personnel. These sections are provided for troubleshooting and advanced setup by qualified service engineers.*

### 3.26 Pass Code Setup Screen

APPI has included a pass code function in all touch screen equipment to prevent operators from changing settings. See Figure 3-44. There are two pass code levels, described as follows:

1. **Level 1:** This is the highest level pass code. The operator cannot access any of the Technical Assistance screens without first entering this code. The default Level 1 pass code, when shipped from the factory, is 1001. To change this code, press the **Level1 PW** button on the Password Setup Screen, enter a new code on the numeric keypad, and press the **ENT** button.

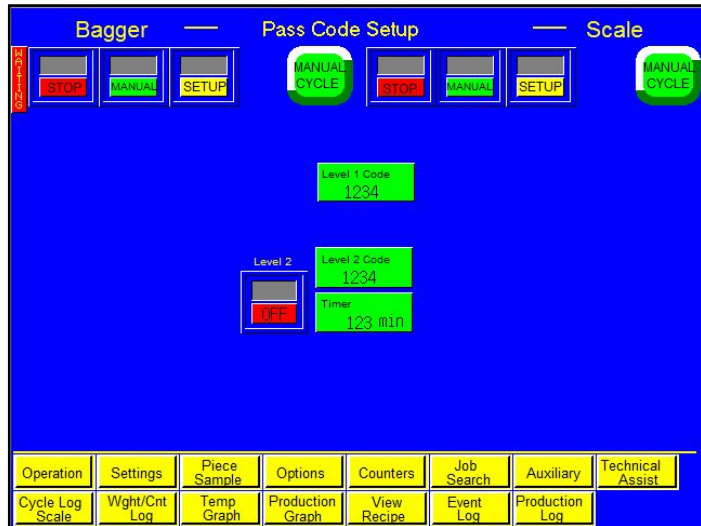

Figure 3-44

2. **Level 2:** This pass code, when the pass code function is enabled, prevents the operator from accessing settings screens that affect the operation of the equipment. If the touch screen defaults back to the Operation screen after a preset amount of time elapses, the operator must enter this code to access settings screens. To change this code, press the **Level2 PW** button on the Password Setup Screen, enter a new code on the numeric keypad, and press the **ENT** button.

Pass codes prevent unauthorized individuals from tampering with settings. When equipment is shipped, APPI uses the following factory set pass codes that should be changed prior to putting the T-1000-S14 into operation:

1. **Level 1 pass code:** 1001
2. **Level 2 pass code:** 1002

To enable the pass code function, press the **Technical Assist** button from the Main Menu. Enter the Level 1 pass code (1001 by default from APPI) on the numeric keypad. Press the **Operation PassCode** button on the Technical Assistance screen to display the Pass Code Setup screen. Then press the **ON / OFF** toggle button to turn the pass code function ON. If the pass codes are changed, ensure that the new codes are written down. Once the pass code function is enabled, the operator will have a programmed amount of time to make changes.

**Timer:** The amount of time, in minutes, the touch screen can remain inactive before the touch screen will automatically default back to the Operation screen. Password Timeout time can be changed on the Pass Code Setup screen by pressing the **Timer** button, entering a value on the numeric keypad and pressing the **ENT** button.

If the codes are misplaced or forgotten, contact the APPI Service Department for assistance. APPI will provide a “factory code” so that the current pass codes can be displayed. Once the factory code is received, press the **F5** function key, located to the right of the touch screen, to enter the factory code. The current pass codes will be displayed.

### 3.27 PLC Info

The PLC I/O screens are provided for maintenance personnel to determine the status of the PLC and to review the mode of outputs and inputs. PLC I/O screens are also used to assist APPI service technicians working with your maintenance personnel to troubleshoot the T-1000-S14/US-9000 in the field. See Figure 3-45.

To determine the function of each input and output, press the LED to display a brief description. The PLC I/O screen also provides the run Hours and Cycles counters. The Hours counter displays the amount of time the machine has been on. The Cycles counter displays the current number of complete cycles. These counters cannot be reset by the operator.

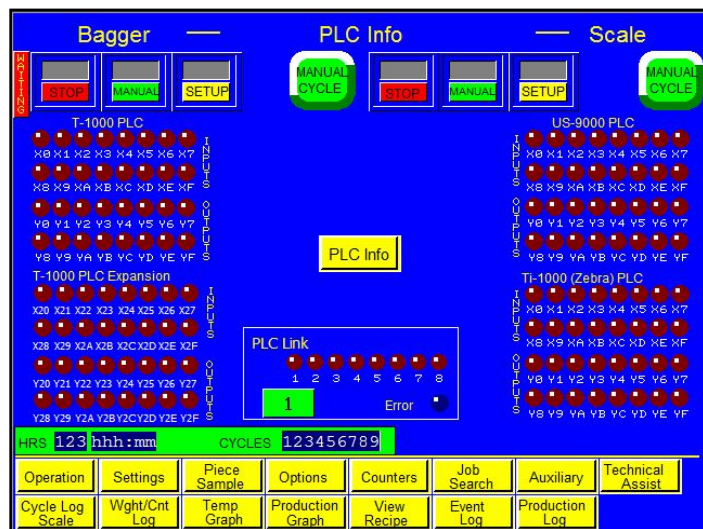

Figure 3-45

The PLC Info screen is accessed by pressing the **PLC Info** button on the Technical Assistance screen.

### 3.28 Bagger Options Enable Screen

The Options Enable Screen is used at the factory to “enable” options for use by the operator. It is accessed by pressing the **Option PassC** button on the Technical Assistance screen. See Figure 3-46.

A status box is located to the left of each option to indicate if the option is available to the operator. If the status box displays ON, the option has been activated. If the status box displays OFF or N/A, the option has not been activated. A password is required to enable inactive options. To obtain the password, the option must first be purchased from Advanced Poly-Packaging, Inc. Contact the APPI Service Department for more information regarding available options for the T-1000-S14 and for instructions on how to activate options.

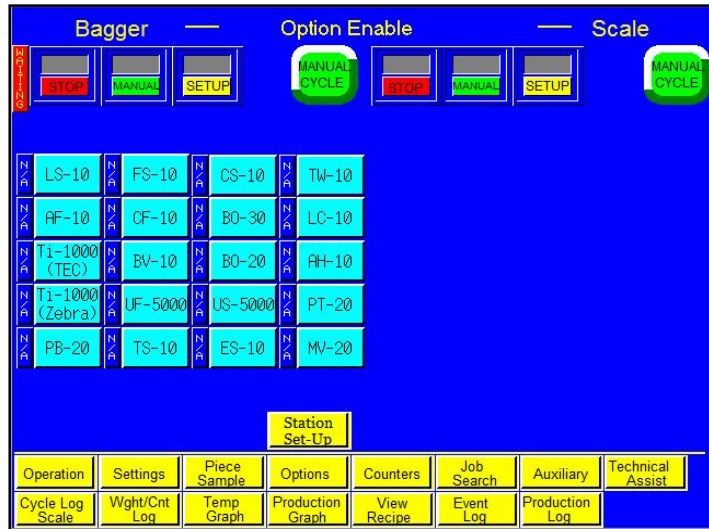

Figure 3-46

### 3.29 Bagger Solenoid Activation

The Solenoid Activation screen allows the operator to set up communications between the bagger and optional auxiliary equipment. See Figure 3-47. This screen is accessed by pressing the **Station Set-Up** button on any option information screen or on the Options Enable screen.

The T-1000-S14 is equipped with a valve station that is wired from a DB25 connector/open ended cable to the PLC. Each wire is pre-assigned to a PLC output, but options are not assigned to a solenoid valve until the machine is ready to ship from the factory.

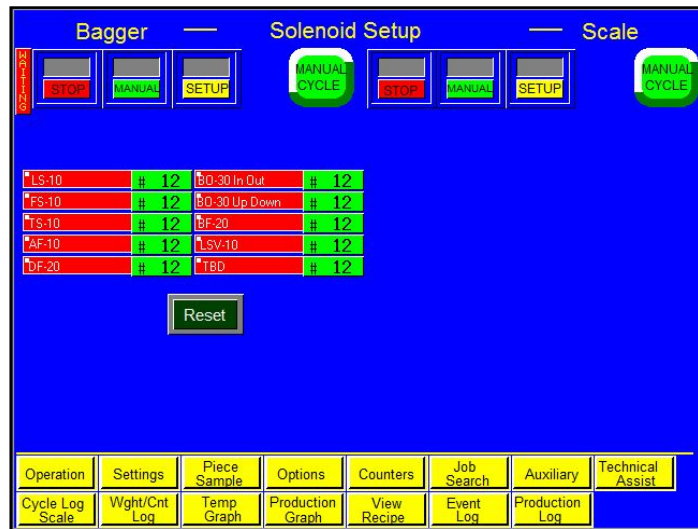

Figure 3-47

Each valve is assigned a “station” number.

Stations 1 through 4 are fixed and are programmed to operate a standard T-1000-S14 in a fixed sequence of operation. However, when options are added, the sequence of operation changes. Additionally, outputs from the PLC to the valve are assigned, depending on the options equipped.

For example, if a LS-10 Load Shelf option is added and the valve station assigned is #6, the Solenoid Activation screen must be accessed and the Load Shelf option assigned to Station #6. To assign an option to a valve station, press the green button to the right of the option and enter the desired number followed by the **ENT** button on the numeric keypad.

*NOTE: Two options cannot be assigned to the same station number. Doing so will display a message screen. The message will also be displayed if the Solenoid Activation screen is exited with two options assigned to the same valve.*

To start over, press the **Reset** button. Contact APPI Technical Support for assistance.



### 3.30 Bagger Factory Settings

The Bagger Factory Settings screen contains additional bagger settings that should only be set by qualified technicians or by the factory. See Figure 3-48. This screen is accessed by pressing the **Bagger Factory** button on the Technical Assistance screen.

**Heat Off:** The amount of time, in minutes, the machine can remain inactive before the heater bar will automatically turn off. The machine will remain on even if the heat is off. To adjust this setting, press the **Heat Off** button on the Bagger Factory Settings screen, enter a value on the numeric keypad, and press the **ENT** button. A suggested setting for Heat Off is 40 minutes.

*NOTE: Once the heat turns off, the machine cannot be operated fully again until the heater bar reaches the preset temperature.*

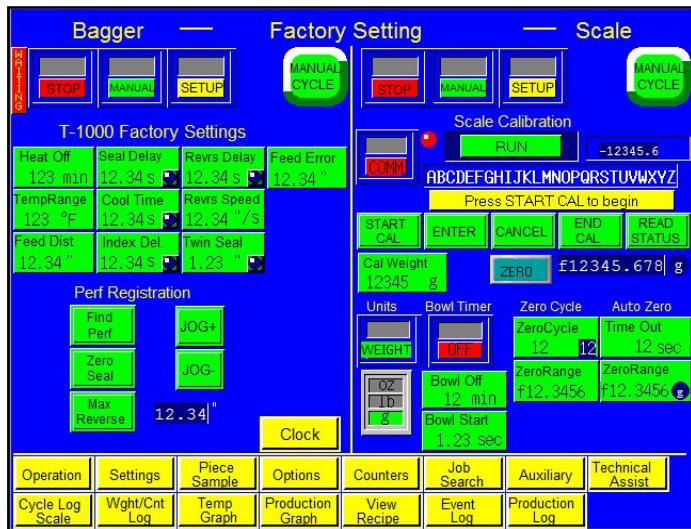

Figure 3-48

**Temperature Range:** The temperature range above and below the Seal Temperature set point the heater bar must reach for the T-1000-S14 to operate fully. For example, if the Seal Temperature is set to 360° and the Temp Range is set to 10°, the temperature would be within the acceptable range if the heater bar temperature was between 350° and 370°. If the temperature is within the acceptable range, the bagger will display “Ready” and the T-1000-S14 can begin normal operation. If the temperature is out of this range, the bagger will display “Waiting” and the T-1000-S14 will only be able to cycle in Setup mode. To change this setting, press the **Temp Range** button, enter a value on the numeric keypad and press the **ENT** button. A suggested setting for Temperature Range is 20°.

*NOTE: It normally takes three to four minutes to bring the heater bar to temperature, depending on the Seal Temperature value and the current temperature of the heater bar.*

**Feed Dist:** The bag length distance, in inches, the perforation sensor does not look for a perforation in the bag when the machine is indexing the bag. To change this setting, press the **Feed Dist** button, enter a value on the numeric keypad and press the **ENT** button. A suggested setting for Feed Distance is 1 inch.

**Seal Delay:** The amount of time, in seconds, before the seal operation begins after the air is turned off. This delay setting allows air to escape the bag. To change this setting, press the **Seal Delay** button, enter a value on the numeric keypad and press the **ENT** button. A suggested setting for Seal Delay is 0 seconds.

**Cool Time:** The amount of time, in seconds, the pressure bar is released from the bag to ensure the seal is cool enough to be torn off after the pressure bar and heater bar have come into contact with the bag. To change this setting, press the **Cool Time** button, enter a value on the numeric keypad and press the **ENT** button. A suggested setting for Cool time is 0 seconds.

**Index Delay:** The amount of time, in seconds, the previous bag has to exit the seal area after it is released and the next bag is fed into place. This delay prevents the next bag from feeding and prevents the seal bar from coming into contact with the previous bag and causing a bag jam. To change this setting, press the **Index Delay** button, enter a value on the numeric keypad and press the **ENT** button. A suggested setting for Index Delay is 0 seconds.

**Reverse Delay:** The amount of time, in seconds, after the bag has been filled and sealed before the bag is reversed. To change this setting, press the **Rev. Delay** button, enter a value on the numeric keypad and press the **ENT** button. A suggested setting for Reverse Delay is 0 seconds.

**Reverse Speed:** The speed, in inches per second, at which the bagger reverses to separate the bag at the perforation. To change this setting, press the **Rev. Speed** button, enter a value on the numeric keypad and press the **ENT** button. A suggested setting for Reverse Speed is 15 inches per second.

**Twin Seal:** The distance, in inches, between the first seal and the second seal. The Twin Seal option seals the bag twice to increase the integrity of the bag. To change this setting, press the **Twin Seal** button, enter a value on the numeric keypad and press the **ENT** button. The Twin Seal option must have been purchased and activated to allow for adjustment of this setting.

**Feed Error:** The amount of acceptable variation, in inches, from the set bag length. For example, if the bag length is 15" and the Feed Error is set to 3", bags with 12-18" lengths would be accepted, but bags with a length of 19" would cause operation to stop and an error message would be displayed. To change this setting, press the **Feed Error** button, enter a value on the numeric keypad and press the **ENT** button. To disable this function, set the Feed Error to zero. A suggested setting for Feed Error is 1 inch.

The Bagger Factory Settings screen also allows the operator to register the perforation. To set up the perforation, follow these steps:

1. Press the **Perf Registr** button on the Bagger Factory Settings screen. The Bag Registration screen will be displayed.
2. Press the **Find Perf** button. The bagger will advance until the perforation sensor finds the perforation, and then the bag will stop.
3. Hold the **JOG+** button until the perforation moves down to the middle of the PTFE sheet area at the heater bar.
4. Release the **JOG+** button.
5. Push the **Zero Seal** button once.
6. Hold the **JOG-** button until the perforation moves up to just in front of the nip rollers.
7. Push the **Max Reverse** button once.

After performing the setup procedure, the bag perforation should now be registered and ready for all bag indexing.

To access the Clock Setup screen and adjust the date and time, press the **Clock** button. See Figure 3-49.

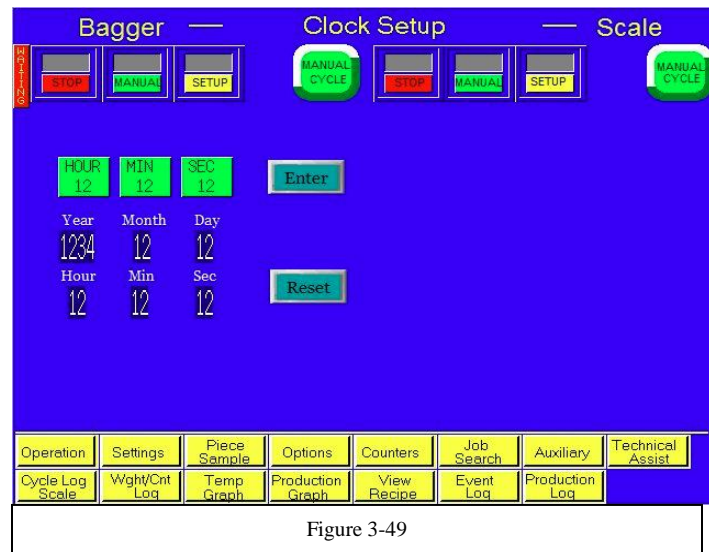

Figure 3-49

### 3.31 Scale Factory Settings

The Scale Factory Settings screen is considered an additional settings screen and should only be accessed by qualified service personnel. See Figure 3-48.

The scale can be calibrated on the Scale Factory Settings screen. The following step-by-step procedure must be followed closely to properly calibrate the scale. A known metric calibration weight (in grams) must be used to properly calibrate the scale. The actual weight may vary, but it should be at least 1000 grams. This weight may vary depending on the magnitude of the load cell. Contact APPI Tech Support to discuss the calibration weight used during this procedure. This weight may also be purchased from APPI.

## CALIBRATION PROCEDURE:

---

1. From the Main Menu, press the **Technical Assist** button.
2. On the Technical Assistance screen, press the **Factory Settings** button.
3. On the Factory Settings screen, press the **Scale Calibration** button.
4. Follow the instructions displayed in the yellow prompt bar.
5. Press the **START CAL** button located near center left of the screen.
6. Wait for the prompt message **New Zero**. When the New Zero message appears, press the **ENT** button.
7. Wait for the **Cal Weight** prompt.
8. Place the sample weight on the scale. The weight must be between 1000 and 9000 grams and must weigh exactly what will be entered in the next step.
9. Press the **CAL WEIGHT** button located under the **ENT** button.
10. Enter the exact Cal Weight that was placed on the scale in the previous step and press the **ENT** button.
11. When the prompt message **Cal OK** appears, press the **ENT** button.
12. When the prompt message **Save?** appears, press the **ENT** button.
13. When prompt message **Exit Setup?** appears, press the **ENT** button.
14. Once the weight displays the same as the sample weight, press the **END CAL** button located on the right center of the screen.

This ends the calibration procedure. **RUN** should now be displayed in the top center of the screen. The scale can now be run with a known weight for testing in operation mode.

The Scale Factory Settings screen features a **Units** toggle button for switching between two modes: Weight mode and Count mode. The **Units** toggle button simply changes how parts are measured on the Settings screen. Toggle this button to Weight to count product based on its weight. Toggle this button to Count to count product based on the quantity.

The Scale Factory Settings screen also allows for switching between different units of measurement, including grams, pounds and ounces. The Zero Cycle and Auto Zero settings can be adjusted on this screen.

**Zero Cycle:** The number of cycles before the scale will automatically zero.

**Zero Range:** The range of weight that is considered zero. This function allows for small amounts of dirt that may fall on the scale due to environmental conditions. For example, if the Zero Range is set to 0.04 grams, the scale will be at zero even if there is 0.04 grams on the scale. However, once the Zero Range value is exceeded (i.e. there are 0.05 grams of dirt on the scale), the scale will not automatically zero. To adjust this setting, press the **Zero Range** button, enter a value on the numeric keypad and press the **ENT** button.

**Auto Zero Settings (Time Out and Zero Range):** The US-9000 is programmed with an auto zero function that allows the scale to automatically zero the scale if two conditions are met:

- 1) The current weight is within the zero range setting.
- 2) The weight has been within the range setting for a preset amount of time (Time Out).

For example, if the Zero Range is set to 0.003 lbs and the Time Out value is 3 seconds, the scale will automatically zero if the scale is not in cycle operation and the current weight displayed is stable at 0.002 lbs. This function allows for more infrequent cleaning of the tray and for environmental conditions that may affect the load cell. However, this function may not eliminate the need to periodically zero the scale manually.

### 3.32 APPI Factory

The APPI Factory displays additional machine information and provides access to more technical assistance screens. This screen should only be accessed by qualified technicians or the factory. To access this screen, a pass code must be entered. See Figure 3-50.

**Default Settings:** Press the **Accept** button under Default Settings to return all the settings back to the original factory settings.

**EEPROM:** Pressing the **Write** button allows the operator to write machine data to the PLC EEPROM. Pressing the **Read** button to retrieve all written data.

**Service Center:** Displays the service center that should be contacted if a problem occurs.

**Frame Type:** Displays the orientation of the machine's frame: horizontal or vertical.

**Frame Size:** Displays the width of the seal frame: 14 inches (S-14) or 18 inches (S-18).

**Temp Units:** Displays whether temperature units will be displayed using the standard system of measurement (Fahrenheit) or the metric system of measurement (Celsius).

The APPI Factory screen allows for adjustment and resetting of the date and time. This screen also displays printer information, such as the type of printer (Next Bag Out or Offline), the type of driver (XiIII or Xi4), the type of drive (Main Drive or Driven Roll) and the printer resolution (200 DPI or 300 DPI).

The **Load Cell** toggle button allows for switching the load cell capacity to greater than or less than 10kg.

Press the **Language Select** button to display the Language Selection screen. This screen allows the operator to change the operating language of the touch screen program.

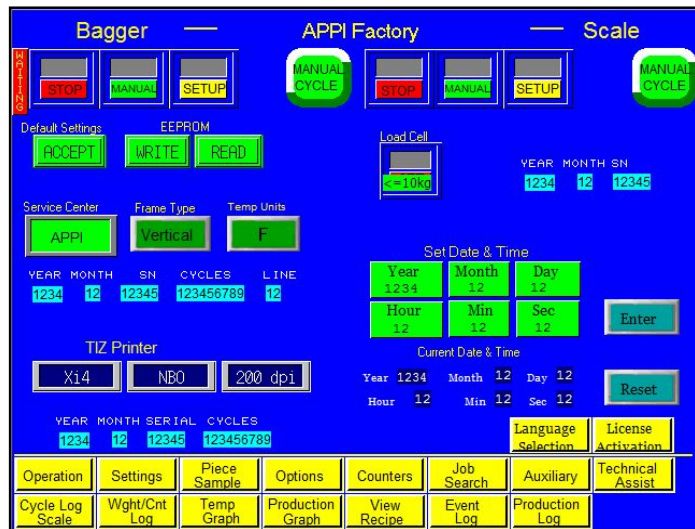

Figure 3-50

### 3.33 Printer Status Screen

If you purchased a printer with the T-1000-S14/US-9000, the Printer Status screen is used to troubleshoot the printer. This screen should only be accessed by qualified technicians or the factory. See Figure 3-51.

The printer sends a status message when turned on and after each print. If an error occurs, the actual error message will be displayed on the Printer Status Screen. To reset the status, press the **Clear Status** button. To recall the status, press the **Read Status** button.



Figure 3-51

**Config Label:** Press this button to print the parameters for the printer.

**Network Label:** Press this button to print the network configuration, including the current IP address.

**Printer Reset:** Press this button to clear labels and start a self test.

**HeadTest Interval:** The number of labels that is printed between tests. To disable this function, set the interval to zero. Press the **Reset** button to set the Head Test Interval to zero.

The Head Cold **ON / OFF** toggle button allows the operator to turn the Head Cold

Warning feature on and off. If the Head Cold Warning feature is on, the machine will automatically stop if the print head gets too cold.

The Bag Out **ON / OFF** toggle allows the operator to turn the Bag Out sensor option on and off. If the Bag Out sensor is enabled, operation stops and an error message is displayed every time the bagger runs out of bags.

### 3.34 Warning and Message Screens

The T-1000-S14/US-9000 touch screen program features many informational screens that are displayed automatically

to alert the operator of situations on the machine. Some messages provide functional messages that describe the status of equipment or errors, and some provide instructions for operators to follow to bring the bagger back online. See Figures 3-52 through 3-54 for examples of messages that indicate the status of the bagger. To reset a message screen, clear the condition first (if required) and then touch the screen.



Figure 3-52

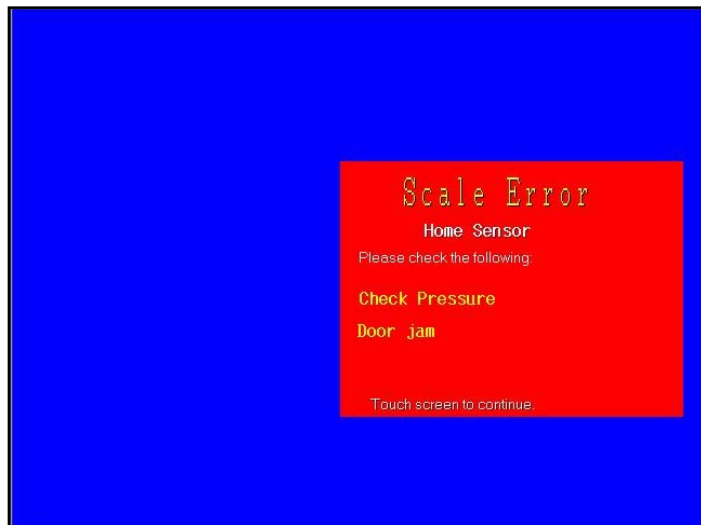

Figure 3-54

# Chapter 4: Adjustments, Maintenance and Troubleshooting

---

Machine Adjustments

Preventative and Scheduled Maintenance

Troubleshooting

Electrical Drawings

## 4.1 Bagger Machine Adjustments

Periodically, the T-1000-S14 will require readjustments or realignments of components to ensure proper operation. Adjustments may be required after transportation, excessive handling or due to normal wear and tear.

**CAUTION: Machine adjustments, electrical troubleshooting and component replacement should be performed by qualified maintenance technicians familiar with safety practices including, but not limited to, equipment lock-out / tag-out, voltages and pneumatics. If you are not familiar with the equipment or have not received training on the T-1000-S14, consult with APPI Technical Support before attempting adjustments or repairs.**

### A. Tracking and Alignment Adjustments

To avoid spillage of product in an automatic loading operation and loss of production in a manual loading operation, make machine adjustments to correct the tracking and alignment of the web of bags.

### B. Compression (Nip) Roller Adjustment

The drive roll compression is the force that exists between the two feed rolls (rubber-covered grooved roll and grooved steel roll). Too little drive roll compression will prevent the bags from tearing off after each sealing operation. Too much drive roll compression will cause extra wear on the drive roll and the motor.

*NOTE: Always clean rollers before adjusting.*

Turn the power switch to the OFF position and unplug the power cord. Remove the left and right side covers. The compression adjustment is located on the lower outside right and left side plates. See Figures 4-1 and 4-2.

Compression adjustment is a two step process. First, the upper and lower rollers are adjusted to make the lower roller parallel to the upper roller. Then, the lower roller is adjusted (raised) for proper compression.

On both the left panel and right panel, loosen the two locking bolts on the upper block of the compression tension assembly. Loosen the nut on the adjustment screw. With the inner frame locked in the UP position, lower the lower roller by turning the adjustment screws counterclockwise until the lower roller is parallel to the upper roller, leaving a 1/16" gap between the rollers. Turn the adjustment screw clockwise alternatively, keeping the lower roller parallel with the upper roller until the rollers come in contact across the width of the rollers. Slightly lower the inner frame and raise again to ensure that when raised again, the rollers touch simultaneously. Then "snug" the upper block bolts and recheck the alignment.

*NOTE: A light source (lamp) positioned to the rear of the T-1000-S14 showing light in the gap of the rollers will assist in judging whether the upper and lower roller are parallel.*

With the rollers parallel and slightly touching, turn each adjustment screw approximately ½ turn clockwise. Then test the compression by putting a bag between the rollers. Attempt to pull the bag between the rollers. If the bag pulls out easily, turn the compression adjustment screws ½ turn clockwise. Continue this adjustment until the bag is slightly difficult to pull out of the rollers.

**CAUTION: Over-tightening of the compression adjustment screws may cause damage to the upper (rubber) roller or the motor.**

When you are satisfied with the compression, slightly lower the inner frame and then slowly raise it until it almost touches the upper roller. If the gap is consistent across the width of the rollers and it appears parallel, lock the inner frame upward and retighten the two locking bolts on the upper block of the compression tension assembly. Then retighten the nut on the adjustment screws. Replace the covers, plug the cord into the power outlet, and turn the main power on.

# LEFT SIDE PANEL COMPRESSION NIP ROLLER ADJUSTMENT

Figure 4-1

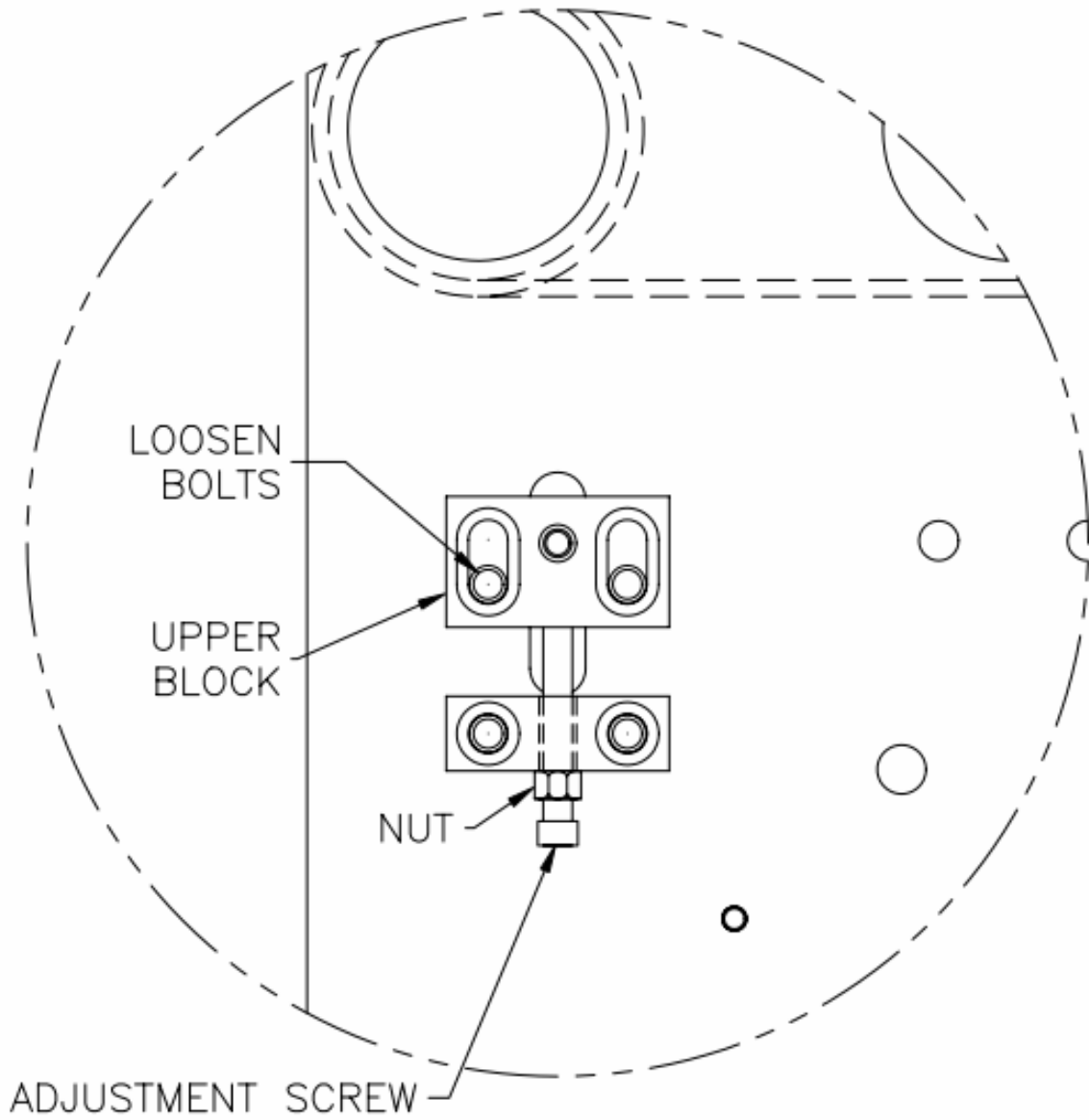



**RIGHT SIDE PANEL COMPRESSION NIP ROLLER ADJUSTMENT**

Figure 4-2

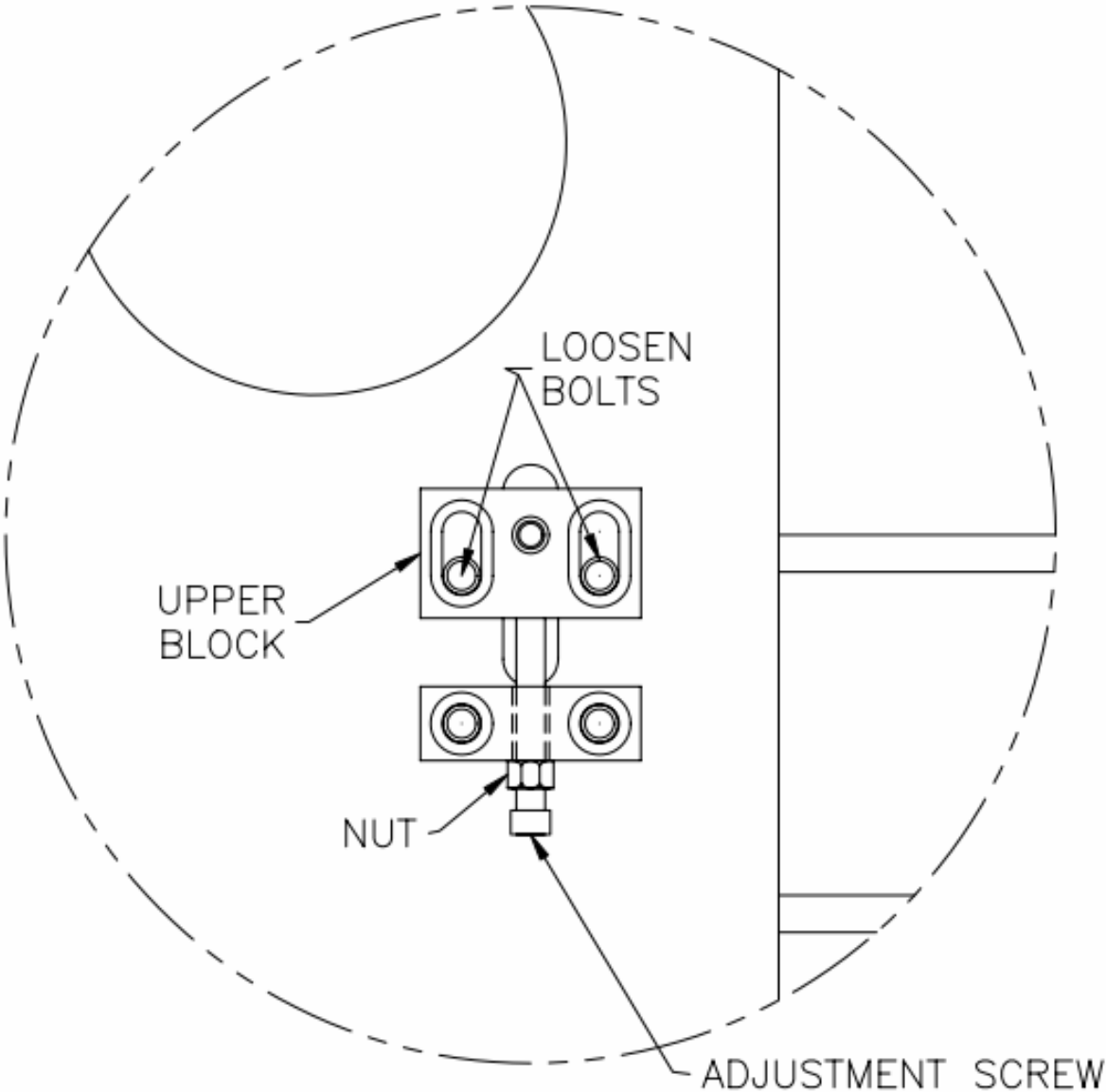

### C. Dancer Assembly Adjustments (Roller Shaft)

A roller shaft, holding in position a roll of bags, will rest on the side plates of the dancer assembly. The roller shaft must be parallel to the upper and lower guide rollers to allow proper tracking through the center of the T-1000-S14. If the roller shaft is not parallel, the web of bags may track to the left or right.

*NOTE: The roller shaft should not be out of alignment unless damaged or jolted in shipment.*

### D. Dancer Bar and Brake Strap Adjustment

The dancer assembly maintains proper bag web tension throughout the stop/start feed motion. Web tension is required for proper tracking. If the tension is insufficient, the web may track left or right. Thinner bags require less tension than thick bags. Web tension is created by the friction of the brake strap along with the weight of the dancer bar pulling downward on the web of bags. Friction of the brake is created by the weight of the bag roll and the spring tension on the brake strap. As the dancer bar rises, spring tension is decreased and friction is decreased. If the web of bags is slack between the dancer roller and nip rollers, there is not enough tension on the bags. If the web of bags breaks prematurely, the tension is too high.

To correct the web tension, the dancer bar or brake strap spring must be adjusted. To increase brake strap tension, relocate the spring on the dancer rail by sliding the block closer to the dancer roller. To decrease tension with the brake strap, move the spring on the dancer bar and slide the block back away from the dancer roller.

The dancer bar pivots on two shoulder bolts that extend from the side plates. The downward force can be adjusted by repositioning the pivot point. To increase tension with the pivot position, move the pivot position away from the dancer roller. To decrease tension, move the pivot position closer to the dancer roller.

*NOTE: For the brake strap to function correctly, the roll shaft must be installed so the strap wraps around the roll shaft. Inspect the dancer bar to ensure that it is parallel to the roller shaft.*

### E. Upper Roller Guides

Two plastic web guides are located on the upper rear roll of the T-1000-S14 and are used for *fine* adjustment of tracking. Once the web is tracking within +/- 1/8" left to right, the plastic web guides can be used to further assist with tracking. Hold the upper roller in place while turning and sliding the plastic guides close to the bags without touching the bags.

*NOTE: If the bags are not tracking properly, the plastic guides could cause the bag web to turn or fold over. If this occurs, slide the guides further away from the web and make adjustments to correct tracking issues.*

*NOTE: If bags have an air relief hole or hanger hole, shift the bag to the right or left of center to avoid having the hole pass directly under the perforation sensor.*

*NOTE: Use the web guides for minor adjustments only. Major adjustment of the guides requires relocation of the bag roll on the bag roll shaft.*

### F. PTFE Adjustment

An anti-stick sheet that prevents the bag from sticking to heater bar surfaces is located immediately behind the front plate. The sheet should periodically be inspected for wear or damage. If holes or tears exist, the rolls can be turned (rotated) to cover the contact surfaces with fresh material.

If a change of sheet is required, turn the main power OFF and unplug the power cord. Lower the inner frame by pulling the handle downward. The rollers are located on the outside lower frame, on the left and right side of the inner frame that extends beneath the side plates. See Figure 4-3.

To adjust the sheet, turn the lower roller clockwise approximately ¼ of a turn using a flathead screwdriver. When fresh material is in place, turn the roller counterclockwise, releasing ALL of the tension on the sheet.

**CAUTION: If sheet tension is not released, the material will tear when the seal bar engages.**

## G. PTFE Replacement

Turn the power to the OFF position and unplug the power cord. Remove the Lexan guard and the four screws that hold the front plate to the inner frame. Pull the front plate from the inner frame and slide the front plate along the guide rods away from the seal assembly. Then slide the rollers and the roller holder away from the heater bar as a unit. Remove and discard the material. Replace the material and rollers with the new material wrapped on the upper roller. Place the rollers on the roller holder, ensuring springs are seated in the grooves on the rollers. Replace the rollers and holder as an assembly (with the unexpanded material on the upper roller). Replace the front plate and tighten the four screws. Adjust the sheet as described in the previous section.

*NOTE: Fiber spacers located behind the front gripper plate may fall when removing the front plate screws.*

## H. Pressure Bar Adjustment

The pressure bar, when actuated by the seal cylinder, is forced against the front plate. The pressure bar must be parallel to the front plate to avoid excessive wear of components. Turn the power to the OFF position and unplug the power cord. Remove the air line from the regulator and remove the top cover. Once the air is removed, the pressure bar can freely be pushed toward the front plate. As the pressure bar approaches the front plate, you can see whether the pressure bar is parallel to the front plate. If it is not, remember which side of the pressure bar touches first, along with the distance of the gap on the opposite side. To make the pressure bar parallel to the front plate, the rear channel that holds the guide rods must be adjusted. Loosen the nuts inside the channel. On the side opposite of the "touching" side, turn the nut located on back side of the channel clockwise the same distance the pressure bar was out of alignment. Tighten the inner-channel nuts and test the pressure bar again by sliding it in and out a few times. Ensure it is parallel to the front plate by slowly pushing it against the front plate. Readjust the nuts on the rear channel as required.

*NOTE: Pressure bar adjustment should only be necessary after rod or bushing replacement.*

## I. Sealer Cylinder Adjustment

Two "speed controls" operate the speed of the cylinder in an "in and out" motion that brings the pressure bar against the front plate (grripper plate). Increasing the speed of the pressure bar will increase production. But if the pressure bar moves in or out too fast, the pressure bar will "bang" and excessive wear will occur. The valve that controls the pressure bar cylinder is located on the main center cylinder on the inner frame. See Figure 4-4.

The adjustment knob (B) controls the speed of the pressure bar INWARD (towards the front plate). The adjustment knob (A) controls the speed of the pressure bar OUTWARD (away from the front plate). To increase the speed of the pressure bar INWARD, turn the knob (B) counterclockwise. To decrease the speed of the pressure bar INWARD, turn the knob (B) clockwise. To increase the speed of the pressure bar OUTWARD, turn the knob (A) counterclockwise. To decrease the speed of the pressure bar OUTWARD, turn the knob (A) clockwise. Adjust the speed of the pressure bar so that it moves in and out rapidly, in a fluid manner, without causing the pressure bar to "bang" in or out.

# RIGHT SIDE PLATE PTFE ADJUSTMENT

Figure 4-3

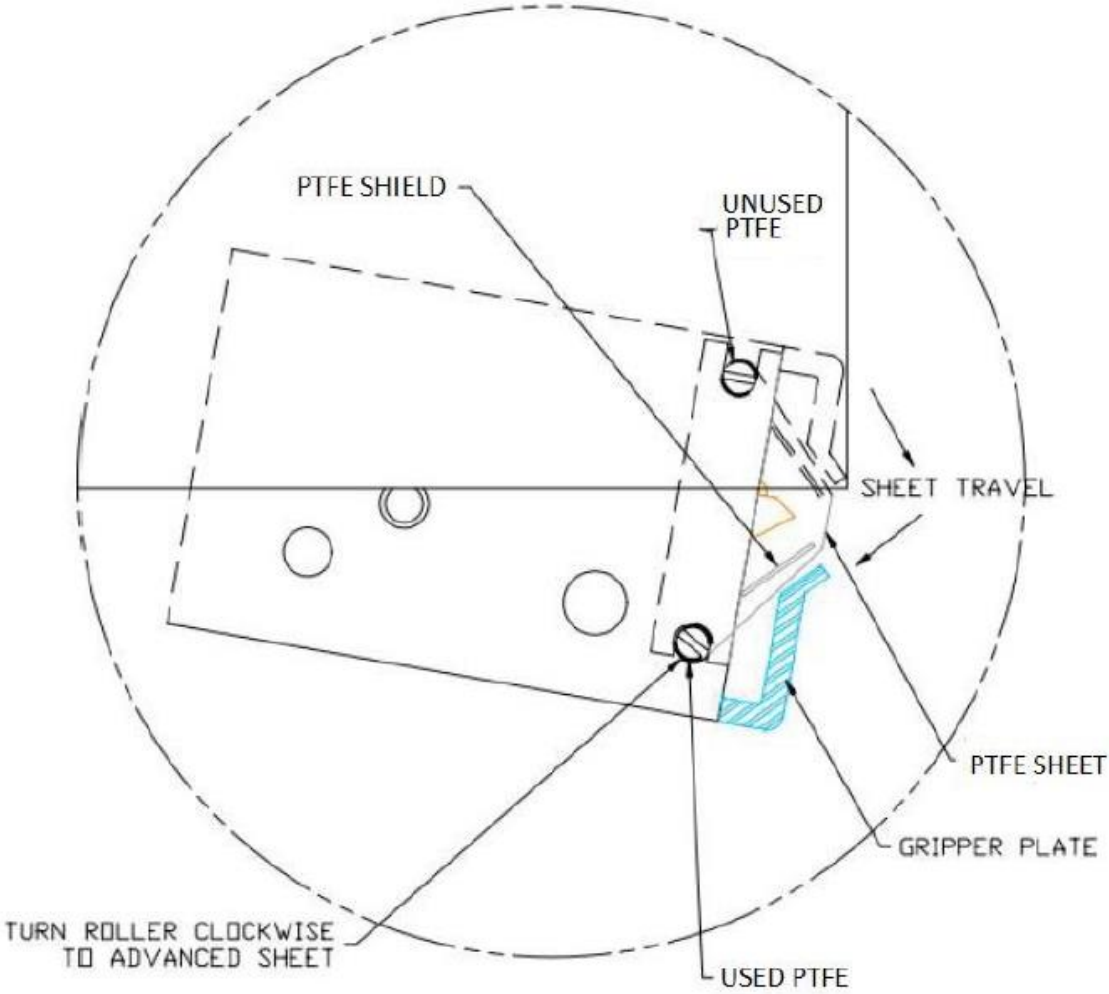

## SEAL CYLINDER ADJUSTMENT

Figure 4-4

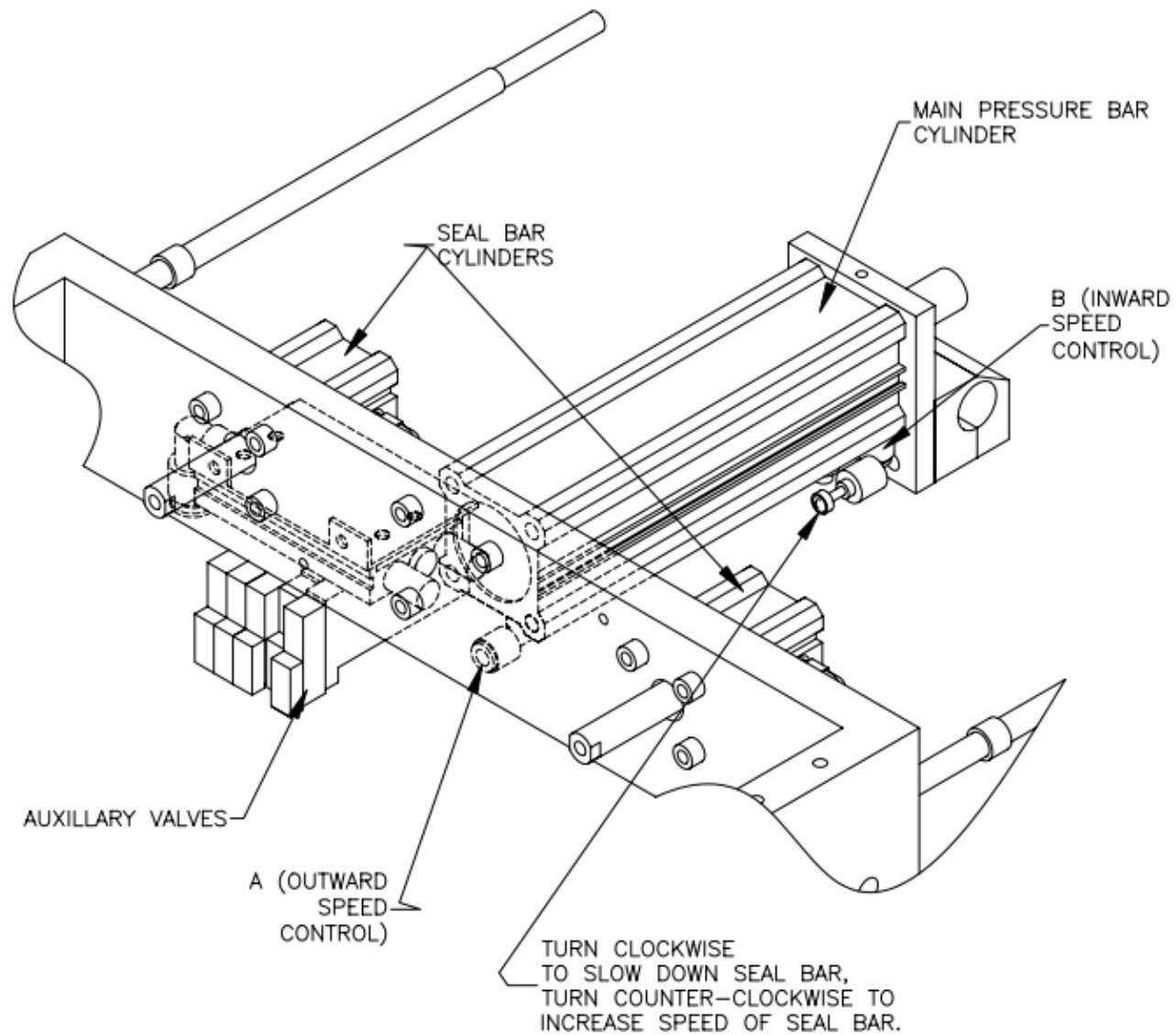

## J. Pressure Bar (Rubber) Replacement

Located along the inside of the pressure bar is a strip of rubber, held on the pressure bar by a channel, pressing on the edges of the rubber. The rubber compresses against the front (gripper) plate holding the bag in place during sealing and bag tear-off. If the rubber becomes brittle, torn, gouged or otherwise worn, it should be replaced to assure strong seals.

To replace the pressure bar rubber, simply pull one end of the rubber from the channel. The rubber will come out of the channel quickly and easily. To install a fresh piece of rubber, press one edge of the rubber into the channel, then the other edge. Work the rubber into the channel in small increments along the length of the channel. See Figure 4-5. If you used PTFE tape to cover the surface of the rubber, place the PTFE on the rubber along its length. If the PTFE extends beyond the rubber, cut off the excess.

*NOTE: PTFE may be added to the pressure bar rubber if the bag sticks to the rubber after loading and sealing. The bag may stick to the rubber if the product and bag are lightweight and if the rubber is dirty.*

*NOTE: Frequently clean the rubber with alcohol to remove buildup of dirt or other contaminants.*

## K. Anti-Jam Adjustment

The anti-jam device is designed to protect the T-1000-S14 from damage when an obstruction is encountered in the seal area (area between the pressure bar and front [gripper] plate). If properly adjusted, the pressure bar will retract if an obstruction is encountered in the seal area. The pressure bar houses springs that cause the rubber and holder to compress. When the rubber holder compresses, a sensor is activated, causing the pressure bar to retract. The sensor is defeated when the pressure bar is approximately 1/8" from the gripper plate. See Figure 4-6. The anti-jam device can quickly be tested while the T-1000-S14 is operating using care, but it should be thoroughly tested by disconnecting air and power and removing covers.

To quickly test the anti-jam device, place a 3/8" diameter flexible poly tube against the front (gripper) plate perpendicular to the seal bar opening. Press the foot switch allowing the pressure bar to compress the poly tube against the front plate. If the pressure bar does not immediately retract and place the T-1000-S14 in the STOP mode, the anti-jam device is not properly adjusted. Test the anti-jam device along the entire length of the pressure bar using the 3/8" poly tubing as a test device.

**CAUTION: To avoid personal injury, do not place fingers or hands into the seal area of the T-1000-S14 while power is ON or air is attached. Do not test the anti-jam device with hands or fingers. Ensure the poly tube that is used for testing is long enough to keep fingers or hands away from the seal area of the T-1000-S14.**

To thoroughly test and adjust the anti-jam device, you must first turn the power to the OFF position, disconnect the air line from the T-1000-S14 and remove the top and left side cover. With the covers removed and air disconnected, turn the power to the ON position.

To test the pressure bar sensor, locate the "X4" LED on the PLC Board and ensure the light is illuminated (ON). Then, compress the rubber and holder into the pressure bar (nylon holder). As soon as the rubber is pressed into the nylon holder, the "X4" LED should turn OFF. The LED should remain off while the rubber is held compressed into the nylon holder. If the "X4" LED shuts off while the rubber bar is pressed into the nylon holder, the pressure bar sensor is functioning properly.

To test the anti-jam override sensor, locate the "X7" LED on the PLC board and ensure that the light is off. Then, standing in front of the T-1000-S14, push the pressure bar slowly towards the front plate, keeping hands and fingers out of the seal area. While pushing the pressure bar towards the front plate, do not compress the rubber into the nylon holder or touch the round nuts on the pressure bar. See Figure 4-6.

## PRESSURE BAR REPLACEMENT

Figure 4-5

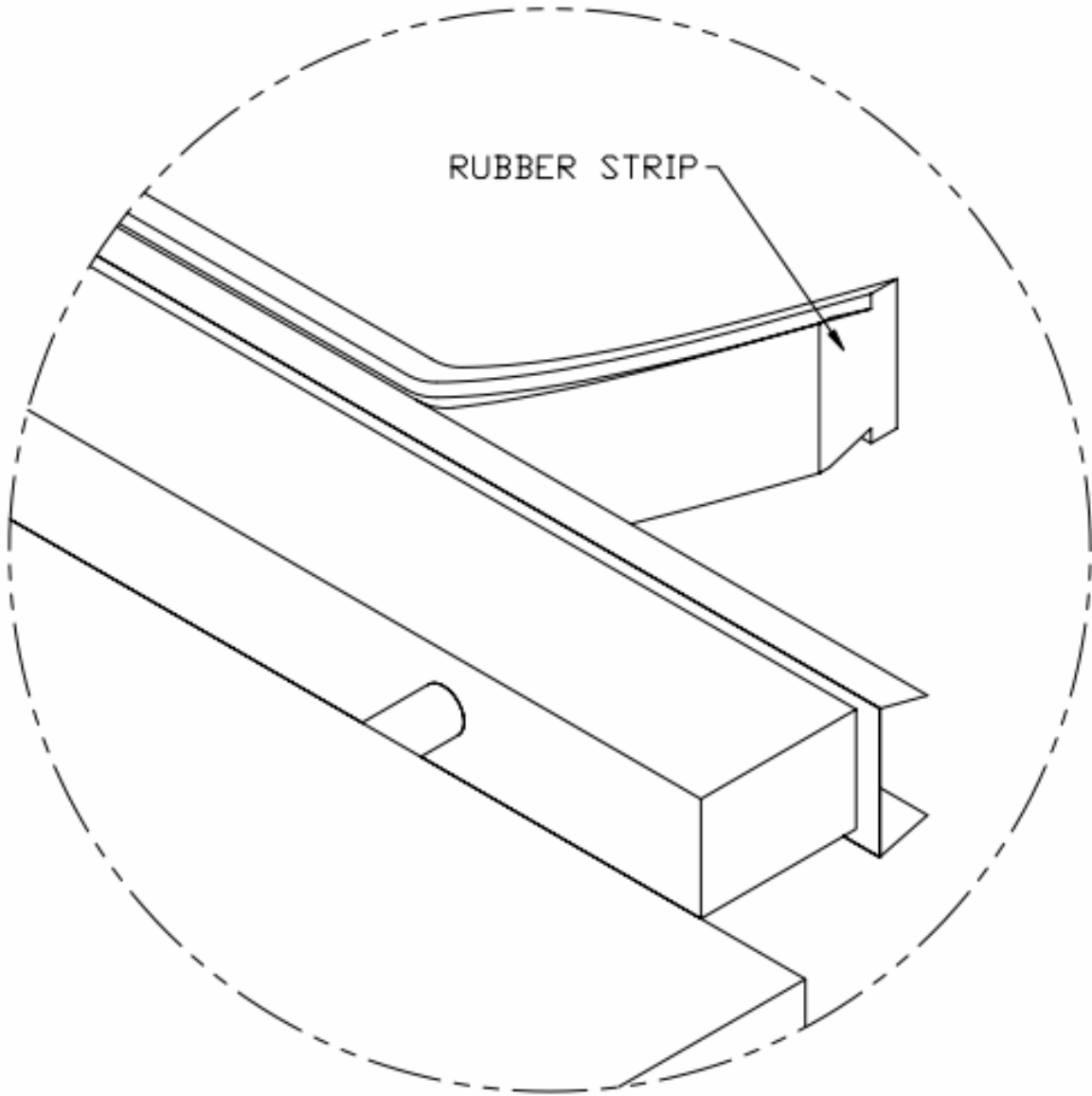

## PRESSURE BAR REPLACEMENT

Figure 4-6

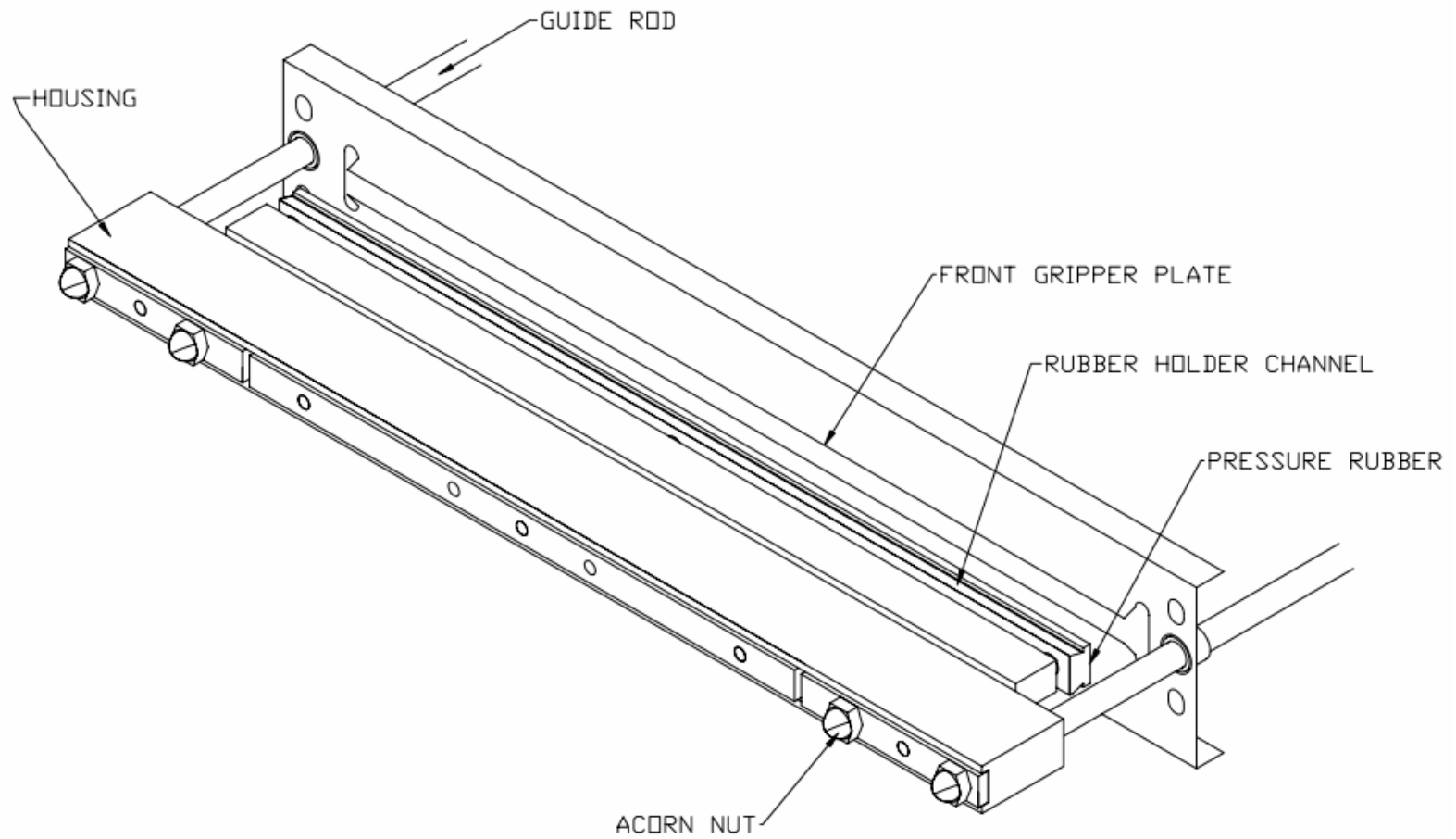



When the pressure bar rubber is approximately 1/8" from the front plate, "X7" LED should illuminate (ON).

If the LED illuminates prematurely (when the rubber is farther than 1/8" from the front plate), the anti-jam override sensor must be adjusted. An aluminum block, located on the right guide rod in the inner frame, houses a magnet. See Figure 4-7. The anti-jam override sensor detects the magnetic field, sending the signal to the PLC. If illuminated prematurely, the "magnetic block" should be moved toward the front of the T-1000-S14 along the guide rod.

If the LED illuminates when the rubber is closer than 1/8" to the front plate or when the rubber is touching the rubber plate (illuminates late), the magnetic block should be adjusted by moving the magnetic block toward the rear of the T-1000-S14 along the guide rod.

To move the magnetic block, loosen the screw on the block that secures it to the guide rod. Loosen the screw just enough to allow the magnet block to slide along the guide rod without pivoting.

After moving the magnetic block, pull the pressure bar away from the front plate and check the illumination of the "X7" LED by pushing the pressure bar slowly toward the front plate. If out of alignment, move the magnetic block in 1/8" increments until properly positioned. In its final position along the guide rod, the magnetic block should be parallel to the side plate.

If the magnetic block, when parallel to the side plate and adjacent to the override sensor, does not cause the LED to illuminate, adjust the override sensor so that the sensor is closer to the magnetic block.

The override sensor is secured to the side-plate with two plastic nuts, one on either side of the side plate. To bring the sensor closer to the magnetic block, loosen the nuts and turn the sensor counterclockwise from inside the frame. Turn the sensor 1/2 turn at a time or until the "X7" LED is illuminated. When illuminated, turn 1/4 turn more.

**CAUTION: To avoid damaging the plastic override sensor, position the sensor so that it does not contact the magnetic block when the pressure bar is moving. To avoid "stripping" the threads of the sensor, do not over tighten the securing nuts.**

When properly positioned, secure the sensor by tightening the securing nuts. When properly adjusted and thoroughly tested, tighten the screw on the magnetic block, replace covers and connect the air line to the regulator.

## L. Heater Cartridge Replacement

A cylinder-shaped cartridge (element), located inside the heater bar, heats the bronze bars that contain it. This cartridge is considered a normal wear item and will infrequently fail, requiring replacement.

To determine if the heater cartridge is bad, use the following troubleshooting steps:

1. Locate the "Y3" indicator on the PLC info screen.
2. Press the **START** button if the T-1000-S14 is in the Stop mode. If "Y3" illuminates in long pulses without increasing the temperature on the Bagger Settings screen, proceed to Step 3.
3. Check resistance value of heater cartridge. It should read between 18-32 Ohms.

*NOTE: If you do not have an Ohms meter, replace the heater cartridge after Step 1.*

To replace the heater cartridge, turn the main power to the OFF position, unplug the power cord and disconnect the air line.

# ANTI-JAM OVERRIDE ADJUSTMENT

Figure 4-7

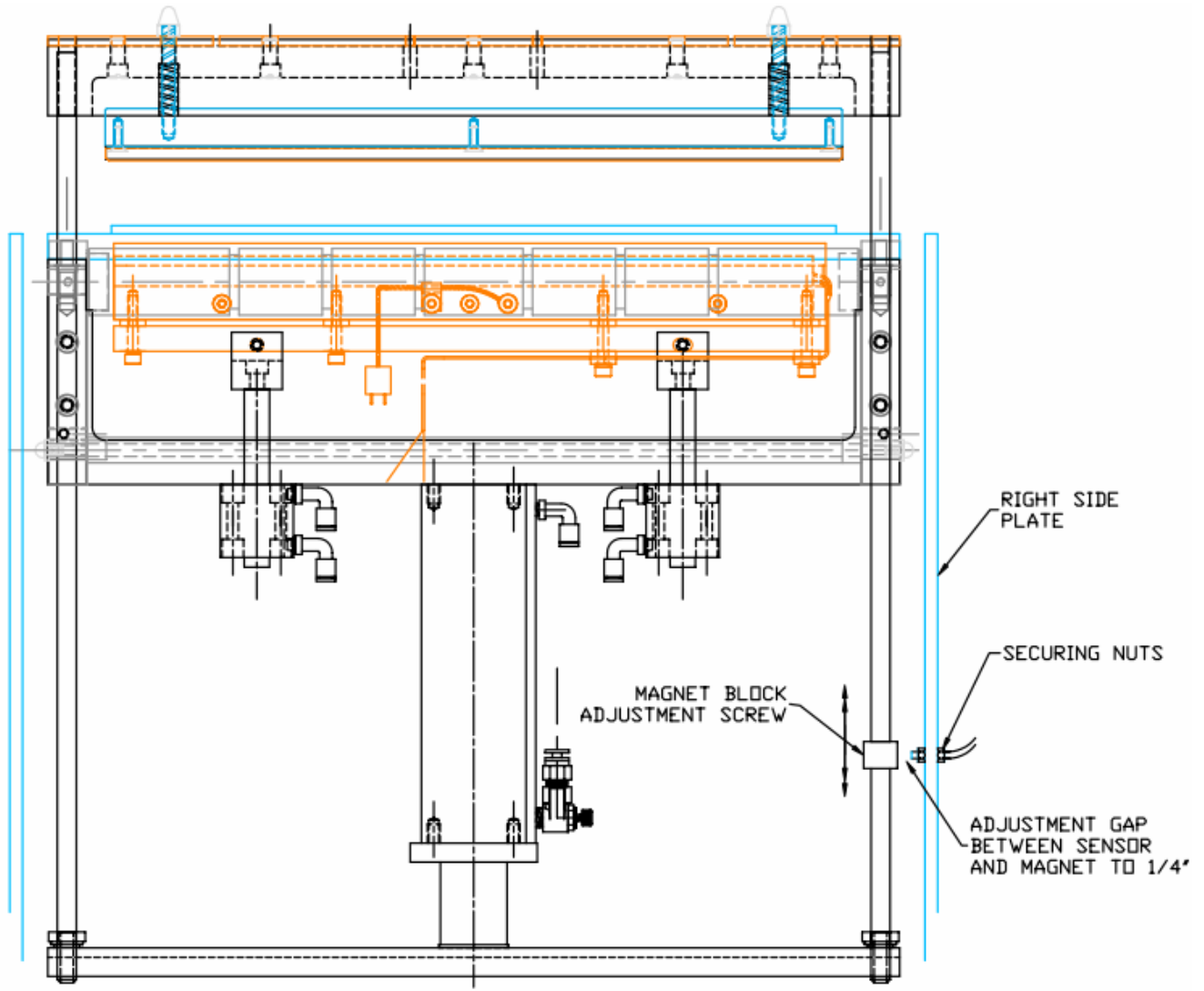

VIEW FROM UNDERNEATH THE INNER FRAME

Disconnect the heater cartridge wire at the connector. From underneath the inner frame, loosen and remove the screws that hold the wire clamp and lower heater bar plate to the upper heater bar plate. See Figure 4-8. Then remove the two remaining screws that hold the lower heater bar plate to the upper heater bar plate. Remove the heater cartridge wires from the wire clamp. Place a new cartridge into the heater bar slot and replace the lower heater bar plate. Place the wires into the wire clamp and secure to the lower heater bar plate. Reconnect the heater cartridge wires, ensuring that the heater bar can extend fully without stretching the heater cartridge wires. Plug the cord into the outlet, turn the power to the ON position and connect the air line to the regulator. Press **START** on the touch screen and verify that the temperature increases.

*NOTE: Heater cartridge wires must make a sharp 90° bend at the end of heater bar. Wires should not extend past the end of the heater bar.*

*NOTE: If the wires rub on the bagger when the heater bar is in or out, the heater cartridge will fall prematurely.*

## M. Replace Thermocouple Wire

A thermocouple wire, brazed to a ring terminal and secured to the bottom of the heater bar, detects the amount of heat the heater bar is emitting. The thermocouple wire is considered a normal wear item and will infrequently fail, requiring replacement.

The thermocouple should be replaced when excessive fluctuations occur or incorrect temperature is displayed in the Bagger Settings menu. The thermocouple should also be replaced when a visual inspection reveals frayed insulation or broken wire. If the above conditions are met, the thermocouple is bad and the current to the heater bar has been turned OFF.

To replace the thermocouple wire, turn the main power to the OFF position, unplug the power cord and disconnect the air line.

Remove the front plate and PTFE assembly. Remove the screws that hold the ring terminal and the jacketed wire clamp. Disconnect the connector and remove the wire. Reverse these steps to replace the wire.

**CAUTION: To avoid stretching or breaking the wire during heater cylinder extension, ensure that the wire is looped and free to bend during heater bar movement.**

Replace the PTFE assembly and front plate.

# HEATER BAR CARTRIDGE REPLACEMENT

Figure 4-8

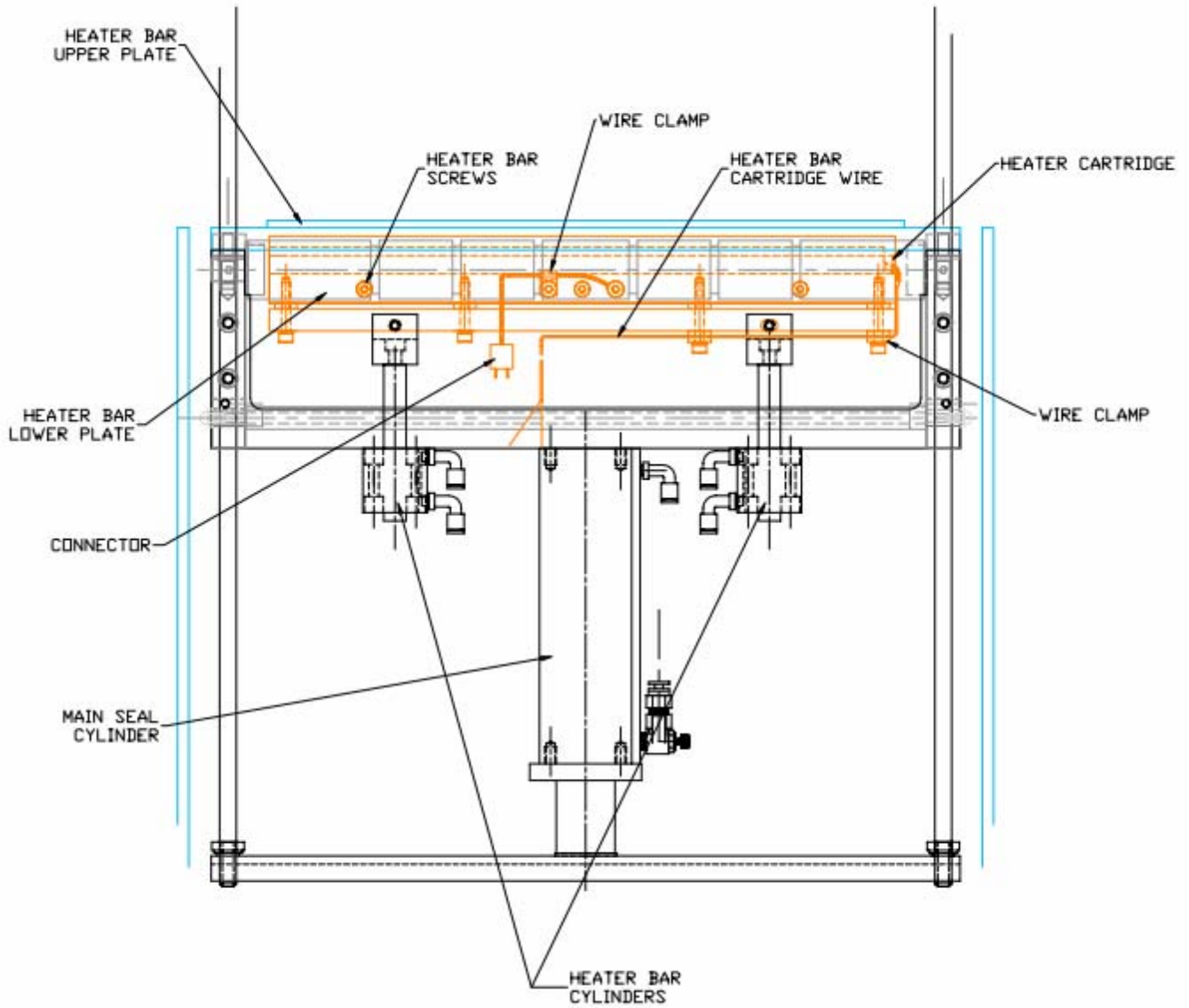

VIEW FROM UNDERNEATH THE INNER FRAME

## 4.2 Scale Adjustments

Periodically, the US-9000 will require readjustments or realignments of components to ensure proper operation. Adjustments may be required after transportation, excessive handling or due to normal wear and tear.

**CAUTION: Machine adjustments, electrical troubleshooting and component replacement should be performed by qualified maintenance technicians familiar with safety practices including, but not limited to, equipment lock-out / tag-out, voltages and pneumatics. If you are not familiar with the equipment or have not received training on the US-9000, consult with APPI Technical Support before attempting adjustments or repairs.**

### A. Bowl Discharge Position

Adjust the bowl by loosening the bolts that hold the base drive to the bottom ring of the bowl and turn the bowl to the desired position. When adjusting the discharge position, care must be taken to insure that the bowl does not contact the weight bucket.

### B. Skivers

Adjust skivers so that parts flow in a consistent, steady, inline pace. Skivers are designed to orient the parts to assist with parts separation.

### C. Level Switch

Vibratory bowls should be consistently fed with parts for best operation. Bowls that are full run slower than empty bowls and inconsistent levels may cause incorrect counts. To maintain a consistent level of parts in the bowl, hoppers or conveyors should be used to feed the bowl. A leveling switch is used to detect the level of parts in the bowl and cause hoppers and conveyors to turn on and feed parts into the bowl.

*NOTE: Hoppers only feed when the bowl is in fast feed mode.*

Several types of level switches may be supplied, depending upon the bowl size and types of parts. If parts are not heavy enough to cause a leveling arm to move, then other types of sensors, such as ultrasonic or photo optic sensors, must be used.

#### **Leveling Arm/Switch Adjustments:**

With a leveling arm, the switch should turn ON when the paddle portion of the arm is approximately 1/2" from the floor of the bowl and should remain ON from 0" to 1/2". Adjust the arm by either resetting the position on the arm on the shaft or by turning an adjustment screw located on the side of the switch.

Some switches also have an LED that when ON, indicates that the switch is ON. The LED should come ON when the paddle is approximately 1/2" above the surface of the bowl. Turn the adjustment screw counterclockwise to raise the paddle before the LED comes on to allow more parts to feed into the bowl before the hopper turns off.

If by turning the screw, the LED does not turn ON at a different paddle position, then the leveling arm must be repositioned. Loosen the screw that holds the shaft of the leveling arm in position and turn the shaft coming out of the sensor block until the LED remains ON when the paddle is touching the bowl up to 1/2" above the bowl. Retighten the screw.

#### **Leveling Switch/Ultrasonic or Photo Optic:**

With a proximity sensor, a proper level of parts may be achieved by moving the sensor closer or further away from the bottom of the bowl. Some sensors have a "training" button which allows for electronic adjustment of sensor to set the level of parts in the bowl. Refer to the manual for these types of switches for further information.

*NOTE: Over filling the bowl will prevent the parts from moving smoothly or may cause the parts to stop flowing.*

## D. Bowl Drive

The drive has several adjustment points to allow for high production parts flow. However, do not advance the drive setting (fast or slow speed) to a higher feed rate than necessary as excessive vibration may decrease the usual output of the feeder. Do not mount external tracks or extensions to the feeder bowl without the manufacturer's approval. Such additions may create dead spots in the feeder bowl or may harm the power unit or decrease the feed rate. Additionally, maintain a gap between the feeder bowl discharge and the scale so that the bowl is not vibrating against the scale housing.

## E. Erratic Feeding of the Bowl

When erratic feeding is observed, first check that the feeder bowl is securely mounted on the drive unit. All mounting screws must be tight. Check the bowl track to be sure there are no physical obstructions causing interruptions in the feed, such as parts stuck under wipers or parts wedged together and jammed between tracks. Check also that coatings on the parts such as mold release compound, oil, dirt or some other foreign matter, may have made the track slippery or sticky, thus preventing the parts drive up the track. A broken spring in any of the spring banks will cause the feed rate to diminish or stop. A broken spring screw will have the same effect. Removal and assembly of each spring bank one at a time will permit examination of springs. A cracked spring will make a dead sound when struck against a hard surface. A broken screw will be self-evident. All drive units are tuned before shipping. Tuning is accomplished by adding springs to the unit until a resonance is established between the driving coils and the mass being driven. A broken spring or loose spring screw destroys this resonance and the feeding ability diminishes or stops.

## F. Dead Spots in the Bowl

Dead spots may occur in either the fabricated or cast bowls and are usually the result of an unequal distribution of mass in the bowl construction caused by tooling. They may also occur when one section of the bowl is not securely fastened to the drive unit, when a weld has broken or when part of the bowl track has loosened. This may be determined by removing the bowl from the drive unit and rotating it 90° from its original position. If the dead spot remains at the same point in the bowl, then it can be assumed that the problem is in the bowl. Dead spots, caused by an unequal mass distribution in the bowl, are generally corrected by adding weight to a selected spot or spots on the outer periphery of the bowl, usually 180° from the dead spot.

## G. Adjustment of the Coil Gap

The XL Series drive units are equipped with two adjustable coils mounted on the base casting and two fixed armatures mounted on the top plate. The air gap between armature and coil is adjusted at the metallic rapping sound develop during feeder operation should not require any further adjustment. Should a continuous metallic rapping sound develop during feeder operation it will indicate that the armature is striking the coil and damage to the feeder unit will occur if not corrected. To adjust the coil for a larger air gap, first back off the two 1/2" socket head cap screws whose centers form a vertical line in the four screw pattern approximately 1/8 of a turn. Then tighten the two 1/2" socket head cap screws whose centers form a horizontal line in the four screw pattern, approximately 1/8 of a turn. This will draw the coil back away from the armature about an additional .009" and should eliminate the metallic rapping sound. Care should be taken to loosen both vertical screws the same amount and tighten the two horizontal screws the same amount so that the surface of the coil remains parallel to the surface of the armature. Normal air gaps run from 0.025" to 0.040". Some units could have as little as 0.015" gap or as much as 0.075" gap. To adjust the coil for less air gap, back off the two horizontal screws and tighten the two vertical screws, the same amount each. Make sure all four screws are tight after making the adjustment.

## H. Spring “Tuning”

The XL Series drive units employ four spring banks for tuning the drive unit. These spring banks usually contain the same number and thickness of springs; however, sometimes due to the bowl construction or bowl tooling, it is necessary to vary the number and thickness of the springs in each bank. When springs of different thicknesses are used in a spring bank, the thickest spring should always be placed so that it is next to the base and top plate castings and the thinner springs toward the screw heads. A smaller diameter and lighter weight bowl will require less or thinner springs or thinner springs than a larger diameter and heavier bowl.

The XL Series drive units are powered by alternating (unrectified) 60 cycle current which energizes the coil at a rate of 120 pulses per second. These pulses cause the coils to magnetize and draw the armature toward them, thereby flexing the springs. The combined spring force must be sufficient to return the armatures to their original or neutral position at the same rate of 120 reactions per second. When this happens, the unit is properly tuned for 60 cycle current. If the power source is 50 cycle, such as used in some European countries, the drive unit must be re-tuned by reducing the number or thickness of springs. If the power source is other than 110/120 Volt, then different coils must be used (240 volt AC coils are available from stock).

## 4.3 Bagger Preventative Maintenance and Scheduled Maintenance

To extend the life of the T-1000-S14, qualified maintenance personnel must perform all required maintenance tasks. Failure to perform scheduled and preventative maintenance may cause excessive wear to components and will void the warranty. For the purpose of this manual, preventative maintenance (PM) tasks are considered periodic tasks that should be performed on a daily, weekly or monthly basis.

Scheduled maintenance tasks are performed when the T-1000-S14 Maintenance Chart Number changes to a higher number. Scheduled maintenance tasks (CHART items) are performed depending on the number of machine cycles and therefore are not considered "periodic" tasks.

### A. Preventative Maintenance Checklist

ITEM	DESCRIPTION	PERIOD
Filter / Air regulator	Drain water from filter	D
Air regulator	Adjust pressure to 80 PSI	D
Anti-jam device	Check operation, adjust as needed (section 4.12)	D
Pressure bar (rubber)	Clean with alcohol	D
Perforation sensor	Clean sensor assembly with alcohol	W
Upper (rubber) roller	Inspect for nicks or cuts; clean with alcohol	W
Lower (alum.) roller	Clean with alcohol	W
Micron filter / Venturi	Inspect for contamination of filter, replace as needed Inspect for blockage / air restriction	M
Wiring / Connectors	Inspect for loose wiring / connectors, tighten as needed	M
Air lines / Valves / Cylinders	Inspect for loose air lines, listen for leaks, tighten or replace poly tubing as needed	M
Compartments / Covers	Remove all covers, clean and blow out compartments with compressed air to remove dust and dirt	M
Side-plates	Clean and wipe down with lightweight oil (based upon environmental humidity conditions)	M
Drive belt	Inspect for wear / fraying, replace if needed	M
Drive belt (right panel)	Inspect for looseness, tighten as required	M
Touch screen cabinet / arms	Tighten set screws	M
Height adjustments screws	Tighten bolts	M

**CAUTION: Unplug power cord and disconnect air line prior to removing guards, funnels or covers. Preventative maintenance must be performed by qualified maintenance personnel.**

Legend for Preventative Maintenance Checklist:

D	Daily
W	Weekly
M	Monthly

**B. Scheduled Maintenance Chart**

ITEM	DESCRIPTION	CHART									
		1	2	3	4	5	6	7	8	9	10
Drive belt (right panel)	Adjust/Inspect for wear replace when necessary	O	O	O	O	O	O	O	O	O	O
Heater element and wiring	Inspect for fraying, cuts, loose connections	O	O	O	O	O	O	O	O	O	O
Pressure bar assembly	Disassemble, clean, inspect springs for wear, breakage (frequency dependent on environment and product)	O		O		O		O		O	
Guide rollers	Inspect for free movement	O	O	O	O	O	O	O	O	O	O
Roller bearings	Inspect for free movement	O	O	O	O	O	O	O	O	O	O
Perf sensor and spring	Inspect for wear, replace when necessary		O		O		O		O		O
Upper rubber roll	Inspect for cuts, unevenness	O		O	O	O	O	O	O	O	O
Lower aluminum roller	Clean with alcohol, inspect for burs	O	O	O	O	O	O	O	O	O	O
Printed circuit boards	Blow off with clean, dry air, inspect for loose wires, connectors	O	O	O	O	O	O	O	O	O	O
Main Seal Cylinder	Listen for air leakage, replace or repair as required	O	O	O	O	O	O	O	O	O	O
Air (blower) filter	Inspect for contamination, replace as necessary	O	O	O	O	O	O	O	O	O	O
Air lines and connectors	Inspect for wear, cuts, leaking, replace as required	O	O	O	O	O	O	O	O	O	O
	INITIALS										

(NOTE: Each chart change represents IMM cycles)



**C. Preventative Maintenance Chart**  
(Options / Auxiliary Equipment)

ITEM	DESCRIPTION	CHART									
		1	2	3	4	5	6	7	8	9	10
	Inspected by: (Initials)										

*Note: Each chart change represents IMM cycles*

**D. Spare Parts Kits**

This section provides two lists of common wear items that may require occasional replacement.

**Level One Spare Parts Kit**

PN: TO-T1-SP10-S14

ITEM	ITEM NO.	DESCRIPTION	QTY
1	TA-T100124-1	HIGH VOLTAGE SENSOR	1
2	TP-215200	SWITCH, MAGNETIC (THREADED BOLT AND NUT)	1
3	TP-T1MA00115	BRAKE TENSION STRAP (DANCER)	1
4	TP-108155	COMPRESSION SPRING, PRESSURE BAR	2
5	TP-111010	COLLARS, SPRING CLOSURE (WEB GUIDE)	2
6	TP-207344	FUSE, 12 AMP, TIME DELAY	2
7	TP-217116	CARTRIDGE, HEATER 800W / 120V	1
8	TP-221416	THERMAL-COUPLE WIRE WITH CONNECTOR	1
9	TP-300500	PTFE SHEET (T-1000-S14)	1
10	TP-306002	SEAL RUBBER STRIP, T-1000-S14-W14	1
11	TP-404266	POLY TUBING, ¼" DIA. (33M ROLL)	10FT
12	TP-404267	POLY TUBING, 3/8" OD DIA. BLUE (20M/RI)	5FT
13	TP-406181	FILTER, 4 MICRON (AIR KNIFE)	1
14	TP-503185	BELT, T-1000-S14	1
15	TP-101131	NUT, ACORN BRASS NICKEL PLATED (¼ – 20)	2
16	D2-5205	¼" TAPE	1 ROLL

## Level Two Spare Parts Kit

PN: TO-T1-SP20-S14

ITEM	ITEM NO.	DESCRIPTION	QTY
1	TP-101131	NUT ACORN BRASS NICKEL PLATED ¼ - 20	2
2	TP-108155	COMPRESSION SPRINGS PRESSURE BAR	2
3	TP-108156	EXTENSION SPRING, PTFE ASSEMBLY	2
4	TP-207344	FUSE 12 AMPS	2
5	TP-215200	SWITCH MAGNETIC	1
6	TP-217116	CARTRIDGE HEATER 800W 120V	1
7	TP-221416	THERMOCOUPLE WIRE WITH CONNECTOR	1
8	TP-300500	PTFE SHEET	1
9	TP-306002	SEAL RUBBER STRIP	1
10	TP-404266	1/4" POLY TUBE	1
11	TP-404267	3/8" POLY TUBE	1
12	TP-406181	FILTER, 4 MICRO (AIR KNIFE)	1
13	TP-503185	MOTOR BELT	1
14	TP-T1MA00115	BRAKE TENSION STRAP (DANCER)	1
15	TP-107160	BUSHINGS 3/8" PTFE COATED	4
16	TP-T1MB00033	SEAL RODS	2
17	TP-T1ME00209	SEAL BAR COILED CABLE HARNESS	1
18	TA-T100124-1	HIGH VOLTAGE SENSOR	1
19	TP-T1MC00017	VULCANIZED RUBBER ROLLER	1
20	TP-501170	MOTOR, VEXTA STEPPER	1
21	TP-T1ME00301	PCB HIGH VOLTAGE BOARD FINISHED	1
22	TP-211386	TRANSFORMER, DUAL VOLTAGE	1
23	TP-214111	BATTER FOR FP SIGMA PLC	1
24	TP-215000	RELAY SOLID STATE 10A G-SERIES	1
25	TP-219455-1	AUX. RELAY UPGRADE (COMPLETE)	1
26	TP-501169-1	5-PHASE MOTOR DRIVER 110 V	1
27	TP-213358	POWER SUPPLY, 25W	1
28	TP-403244	CYLINDER SEAL NCQ2A4OUJA950549	1
29	TP-T1MB00111	RUBBER STRIP HOLDER	1
30	TP-403245	CYLINDER, HEATER BAR	1
31	TP-T1MB00008	HEATER BAR MOUNTING PLATE	1
32	TP-T1MB00010	TIE BAR, T-1000-S14 SEAL BAR	1
33	TP-T1MB00026	GRIPPER PLATE SPACER	2

## 4.4 Bagger Troubleshooting Guide

The items included in this section cover the common causes of trouble that an operator might encounter during the operation of the T-1000-S14. When operating difficulties occur, the best procedure is to observe what is happening, identify the causes and effect the correction. Make only one adjustment at a time, checking the results of each adjustment. If an adjustment does not help or escalates the problem(s), return the settings back to the former position.

**CAUTION: These tests and repairs should be performed only by qualified mechanics or electricians and at their own risk.**

*NOTE: When troubleshooting a T-1000-S14 functioning within a system (i.e. with conveyors, scales, feeders, counters, etc.), always isolate the equipment and operate each machine individually.*

### A. Troubleshooting Checklist

PROBLEM	POSSIBLE CAUSE	CORRECTIVE ACTION
Touch screen does not display	<ol style="list-style-type: none"> <li>1. Power off</li> <li>2. Loose connection</li> <li>3. Fuse blown</li> <li>4. Contrast out of adjustment</li> </ol>	<ol style="list-style-type: none"> <li>1. Plug in power cord / turn on</li> <li>2. Tighten connections</li> <li>3. Replace fuse(s)</li> <li>4. Adjust screen contrast</li> </ol>
No main power light	<ol style="list-style-type: none"> <li>1. Blown fuse</li> <li>2. Bulb out</li> </ol>	<ol style="list-style-type: none"> <li>1. Replace fuse</li> <li>2. Replace bulb</li> </ol>
Pressure bar does not move when foot switch is operated	<ol style="list-style-type: none"> <li>1. Disconnected air line/foot switch</li> <li>2. Power off</li> </ol>	<ol style="list-style-type: none"> <li>1. Hookup air line</li> <li>2. Turn on power</li> </ol>
Pressure bar moves inward but does not reach the front plate (retracts immediately)	<ol style="list-style-type: none"> <li>1. Anti-jam improperly adjusted</li> <li>2. Misalignment of guide rods</li> <li>3. Insufficient air pressure</li> <li>4. Loose / broken ground wire on guide rods</li> </ol>	<ol style="list-style-type: none"> <li>1. Adjust anti-jam (section 4.12)</li> <li>2. Align guide rods (section 4.6)</li> <li>3. Increase air pressure</li> <li>4. Connect / tighten ground wires</li> </ol>
Pressure bar presses against front plate but does not seal bag	<ol style="list-style-type: none"> <li>1. Seal time too low</li> <li>2. Heat (temperature) too low</li> <li>3. Heater cartridge bad</li> <li>4. Insufficient air pressure</li> <li>5. Misalignment of guide rods</li> <li>6. PTFE folded over</li> <li>7. Heater bar not extending</li> <li>8. Seal cylinder bad</li> <li>9. Heater bar cylinder(s) bad</li> </ol>	<ol style="list-style-type: none"> <li>1. Increase in Settings screen</li> <li>2. Increase in Settings screen</li> <li>3. Replace heater cartridge</li> <li>4. Increase air pressure</li> <li>5. Align guide rods</li> <li>6. Turn PTFE</li> <li>7. Check heater bar cylinders / valve</li> <li>8. Replace cylinder / valve</li> <li>9. Replace cylinder / valve</li> </ol>
Bag sticks to PTFE or pressure (rubber) bar	<ol style="list-style-type: none"> <li>1. Seal temperature too high</li> <li>2. Seal time too high</li> <li>3. PTFE in poor condition</li> <li>4. Rubber is dirty / contaminated</li> </ol>	<ol style="list-style-type: none"> <li>1. Decrease temp in Settings screen</li> <li>2. Decrease seal time in Settings screen</li> <li>3. Turn / replace PTFE</li> <li>4. Clean / replace pressure bar rubber</li> </ol>
Bag does not tear off completely	<ol style="list-style-type: none"> <li>1. Bag slipping through rollers</li> <li>2. Compression pressure insufficient</li> <li>3. Drive roller not reversing</li> <li>4. Bag did not index properly</li> <li>5. Seal rubber dirty / worn</li> </ol>	<ol style="list-style-type: none"> <li>1. Clean upper and lower rollers with alcohol to remove slip and dirt build-up</li> <li>2. Adjust roller compression</li> <li>3. Check Reverse setting</li> <li>4. Index another bag for test</li> <li>5. Clean / replace rubber</li> </ol>
Two bags index from rollers	<ol style="list-style-type: none"> <li>1. Bag is folded over</li> <li>2. Perf sensor dirty / damaged</li> <li>3. Perf sensitivity out of adjustment</li> <li>4. Ungrounded outlet causing electrical noise</li> </ol>	<ol style="list-style-type: none"> <li>1. Lower inner frame and straighten bag</li> <li>2. Clean / replace perf sensor</li> <li>3. Contact APPI for perf adjustment</li> <li>4. Plug into "clean" power source</li> </ol>

	5. Auxiliary equipment: noise 6. Seal point value too high	5. Contact APPI for solution 6. Set value lower
Bag does not completely index	1. Perf is sensing hole in bag (vent) 2. Seal position setting too low	1. Reposition bag 2. Increase seal position in Settings screen
Bag web indexing to floor level without stopping on bag	1. Perf sensor not sensing bag 2. Dirty / damaged sensor 3. Perf sensor out of adjustment	1. Contact APPI for adjustment 2. Clean / replace sensor 3. Contact APPI for adjustment
Bags web breaking prematurely in machine	1. Improper web tension 2. Web dragging foreign objects 3. Bag roll side plates bent inward	1. Adjust tension 2. Remove obstructions 3. Repair / remove side-plates

## B. PLC IO Listing

The Main PLC and Expansion PLC IO (Inputs and Outputs) listing is provided to assist in troubleshooting the T-1000-S14.

T-1000-S14 Main PLC				
	Input	Description	Output	Description
	X0	Reserved for Stepper control	Y0	Stepper PulseTrain CW
	X1	Perf Sensor	Y1	Stepper PulseTrain CCW
	X2	Spare	Y2	H/V Trigger
	X3	AF10 Home Sensor	Y3	Heater control
	X4	Jam Detect Sensor	Y4	Air Blower Solenoid
	X5	CF-10 Part Counting Eye	Y5	Air Pulse Solenoid
	X6	Auxiliary In	Y6	Heater Bar Solenoid
	X7	Seal Bar In Sensor	Y7	Seal Bar Out Solenoid
	X8	Foot Switch	Y8	Seal Bar In Solenoid
	X9	Out of Bags Sensor	Y9	Blow Off Solenoid
	XA	Frame Open Sensor	YA	TIZ NBO Print Request
	XB	TI1k Printer Ready	YB	Station #5 Solenoid
	XC	TI1k Printer Error	YC	HV Armed (for 220V)
	XD	Palm Button Left	YD	LC-10 Power Relay
	XE	Palm Button Right	YE	TIZ OFL Print Request
	XF	Aux Fault	YF	Auxiliary Out
T-1000-S14 Expansion PLC				
	X20	UF5K Flight Sensor	Y20	UF5k Run
	X21	UF5K Part Sensor	Y21	UF5k Auxiliary Out
	X22	UF5k Drive Alarm	Y22	Good Bag
	X23	UF5K Aux In	Y23	Med Flat Seal Down Solenoid
	X24	E-Stop	Y24	Med Flat Seal Out Solenoid
	X25	Light Curtain Signal	Y25	Stack Light Red
	X26	DF-20 Eye	Y26	Stack Light Amber
	X27	Spare	Y27	Stack Light Green
	X28	Dumper Home Sensor	Y28	Station #6 Solenoid
	X29	Dumper Out Sensor	Y29	Station #7 Solenoid
	X2A	MV-10 Temperature Alarm	Y2A	Station #8 Solenoid
	X2B	MV-10 Pressure Alarm	Y2B	Station #9 Solenoid
	X2C	BCVer NO Error	Y2C	Station #10 Solenoid
	X2D	BO-30 Bag Open Sensor	Y2D	Base Height UP Solenoid
	X2E	BO-30 Home Sensor	Y2E	Base Height DOWN Solenoid
	X2F	Spare	Y2F	UF5k: Conveyor Drive Alarm Reset

## 4.5 Scale Troubleshooting Guide

The items included in this section cover the common causes of trouble that an operator might encounter during the operation of the US-9000. When operating difficulties occur, the best procedure is to observe what is happening, identify the causes and effect the correction. Make only one adjustment at a time, checking the results of each adjustment. If an adjustment does not help or escalates the problem(s), return the settings back to the former position.

**CAUTION: These tests and repairs should be performed only by qualified mechanics or electricians and at their own risk.**

*NOTE: When troubleshooting a US-9000 functioning within a system (i.e. with baggers, conveyors, feeders, counters, etc.), always isolate the equipment and operate each machine individually.*

### A. Troubleshooting Checklist

Part sensor (eye) not functioning	1. Part dust in eye 2. Eye cables loose/damaged	1. Wipe inside of eye 2. Check eye cables
Bowl not driving well or not at all	1. Bowl overfilled 2. Max Speed/Min Speed values set too low 3. Bowl drive cable loose/damaged	1. Empty bowl 2. Check values on "Settings Screen" 3. Check bowl drive cable
Hopper does not run	1. "Hopper toggle switch" is "off" 2. Part level in bowl too high  3. Hopper cable loose/damaged 4. Level sensor cable loose/damaged 5. Hopper fuse blown	1. Check switch on "Operation Screen" 2. Move parts so level arm can touch the bottom of the bowl 3. Check hopper cable 4. Check level sensor cable 5. Replace fuse #2 on the module
Bowl overfills	1. Gate on hopper raised too high 2. Ramp on front of hopper sloped down too far 3. Hopper running after bowl is full 4. Level sensor cable damaged	1. Lower gate 2. Raise ramp  3. Adjust part level sensor 4. Check level sensor cable

### B. PLC IO Listing

The Main PLC IO (Inputs and Outputs) listing is provided to assist in troubleshooting the US-9000 Scale.

US-9000 Main PLC				
	X0	Spare	Y0	Spare
	X1	Spare	Y1	Spare
	X2	Spare	Y2	Auxiliary Out
	X3	Auxiliary In	Y3	Hopper Drive Enable
	X4	Level Sensor	Y4	Bowl Drive Enable
	X5	Clam Shell Sensor	Y5	Infeed Conveyor
	X6	Spare	Y6	Take Away Conveyor
	X7	Spare	Y7	Spare
	X8	Flip Home Sensor	Y8	Flip Solenoid
	X9	Flip Out Sensor	Y9	Spare
	XA	Custom IF: ToteFull	YA	Custom IF: Good Count
	XB	Spare	YB	Custom IF: Reject Count
	XC	Spare	YC	Custom IF: Machine Fault
	XD	Spare	YD	Spare
	XE	Spare	YE	Spare
	XF	Spare	YF	Scale Fault

## 4.6 Electrical Drawings

Electrical drawings are provided at the end of this chapter to assist in troubleshooting the T-1000-S14/US-9000.



# Electrical Drawing

110 VAC

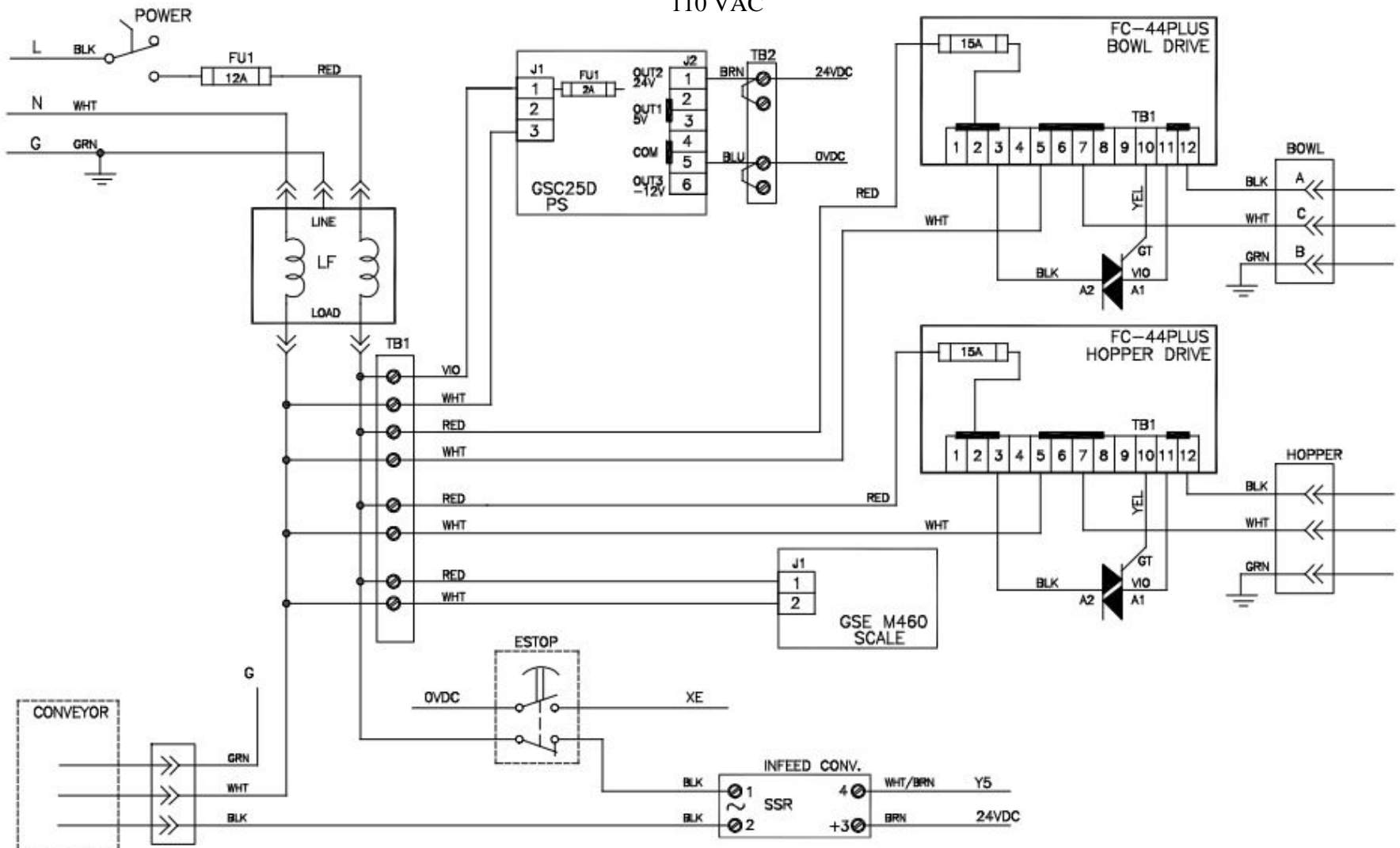

# Electrical Drawing

## COM 4

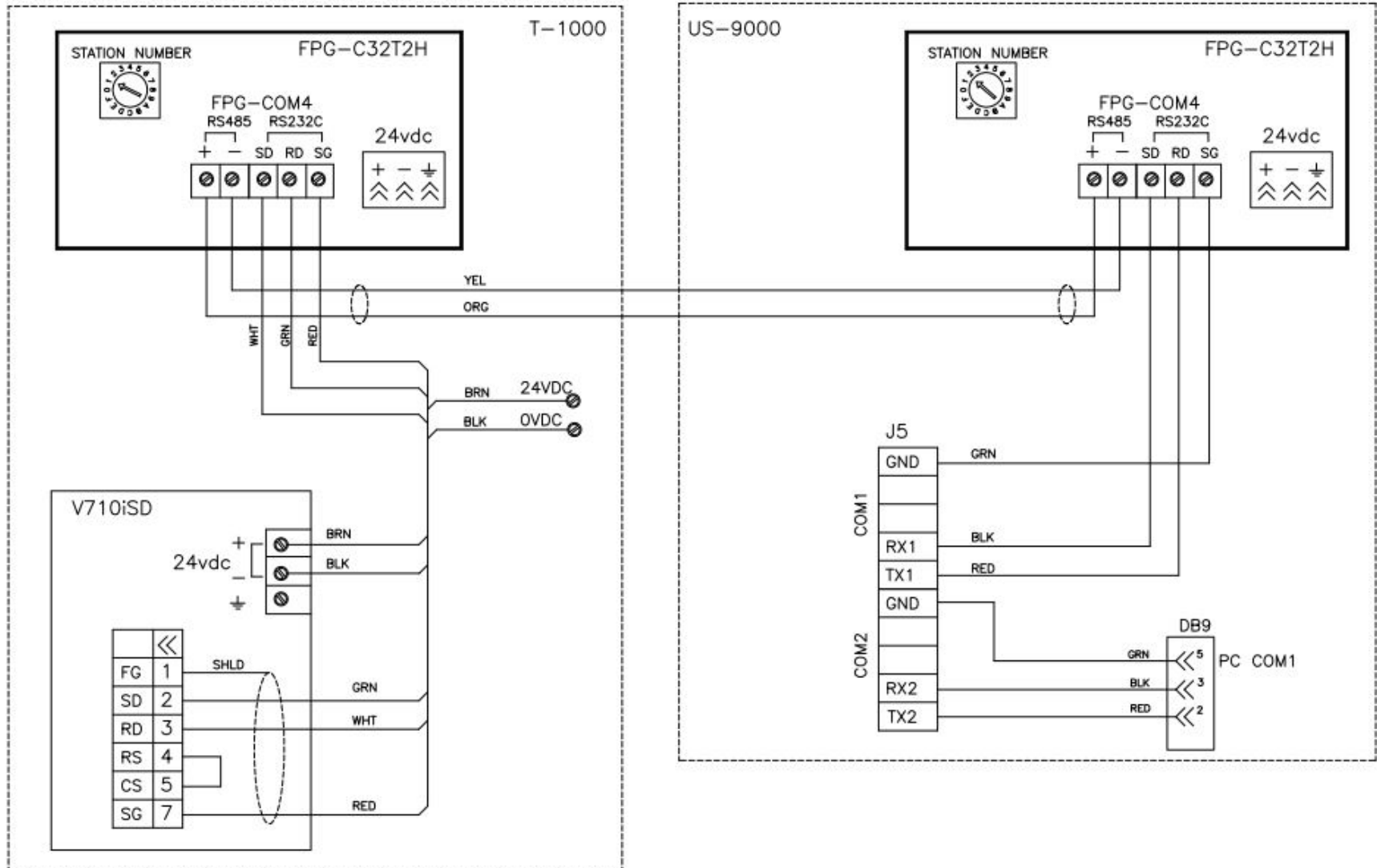



# Electrical Drawing

## ESTOP

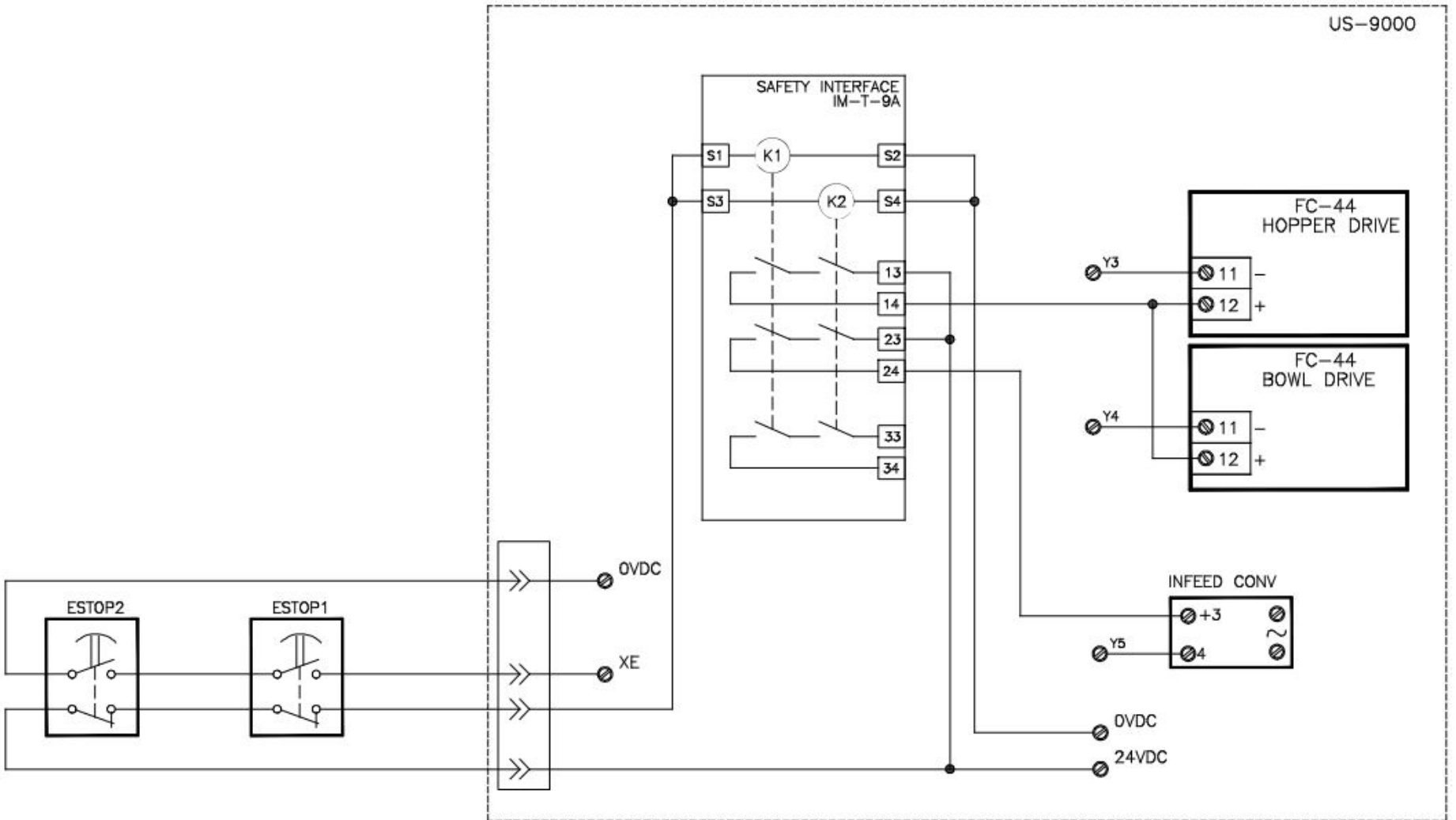

# Electrical Drawing

## LINK3

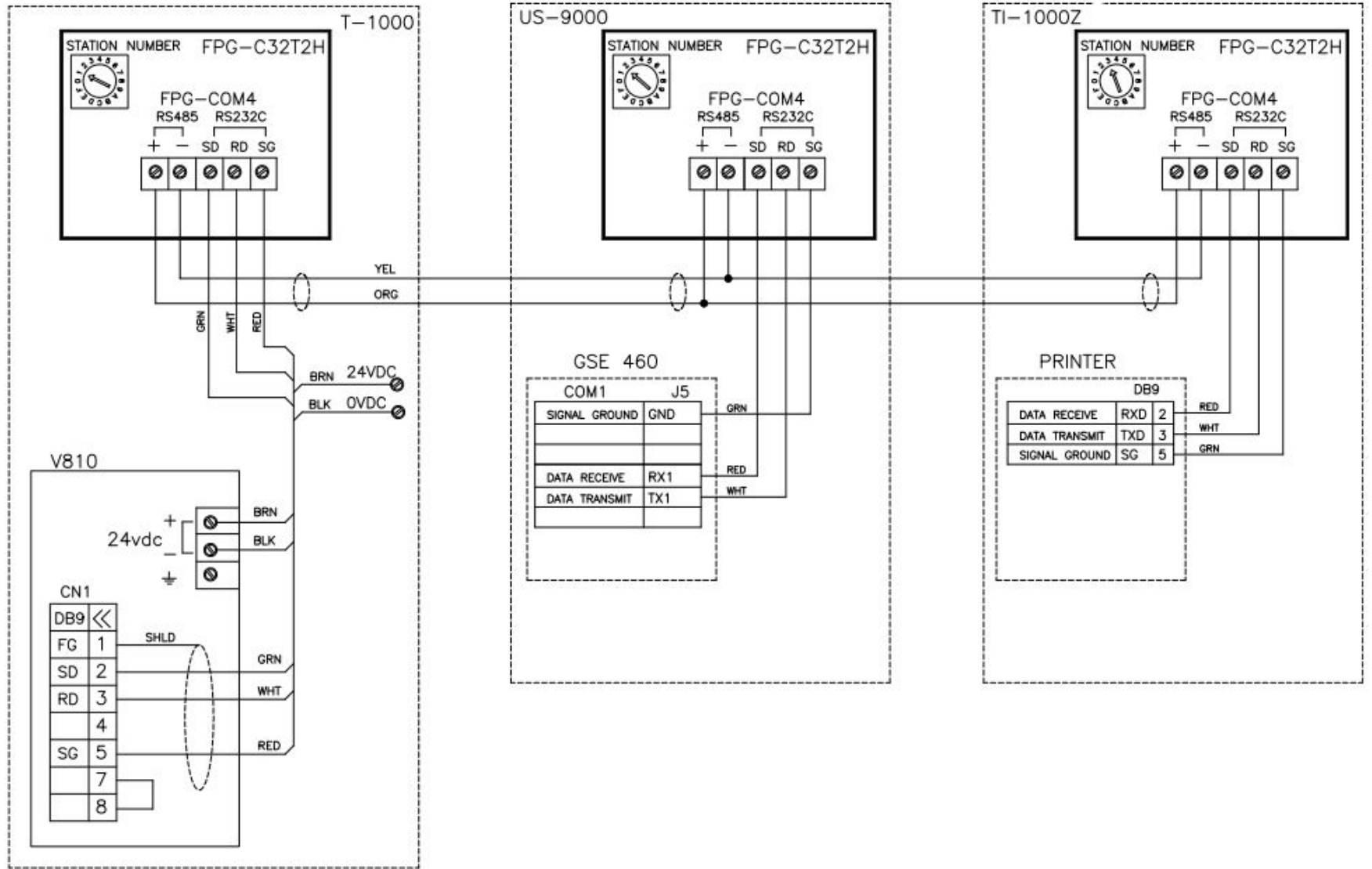

This page intentionally left blank.

# Chapter 5: Parts and Drawings

---

US-9000 Scale Parts and Drawings

Custom Hopper Conveyor Parts Lists and Drawings

T-1000-S14 Bagger Parts and Drawings

## US-9000 Net-Weigh Scale

---

T-US9000

ITEM NO.	QTY.	PART NO.	DESCRIPTION	SECTION NO.	PAGE NO.
1	1	TA-T9-1000	ELECTRONICS MODULE	5.1	
2	1	TA-T9-3000	TOUCH SCREEN ASSEMBLY	5.2	
3	1	TA-T9-4000	STAND ASSEMBLY	5.3	
4	1	TA-T9-5000	SCALE HEAD ASSEMBLY	5.4	
5	1	TA-T9-6000	DANCER ASSEMBLY	5.5	
6	1	TA-T9-7000	BOWL ASSEMBLY	5.6	
7	1	TA-T9-8000	CHUTE ASSEMBLY	5.7	
8	1	TA-T9-9000	SUPPLY HOPPER ASSEMBLY	5.8	
9	1	TA-T10100-S14	HEAD ASSEMBLY	5.9	

**T-1000-S14/US-9000 SYSTEM**

---

CUSTOM SYSTEM



## 5.1 Electronics Module

PN: TA-T9-1000

ITEM NO.	QTY	PART NO.	DESCRIPTION
1	1	TP-MM1-0001	ELECTRONICS BACK PANEL
2	1	TP-MM1-0002	ELECTRONICS PANEL
3	1	TP-MM1-0003	BACK COVER
4	1	TP-MM1-0004	FRONT COVER
5	2	TP-MM1-0005	STAND-OFF
6	1	TP-205108	EMI FILTER, CORCOM
7	1	TP-219455-1	AUXILIARY RELAY
8	1	TP-224001	PCB, SUPPLY HOPPER CONTROLLER
9	2	TP-112240	POWER CORD STRAIN RELIEF
10	1	TP-212410	AC OUTLET
11	2	TP-212248	CONNECTOR, MULTIPOLE RECTANGULAR
12	1	TP-207216, TP-207344	FUSE HOLDER AND FUSE
13	1	TP-212160	5 POS MINI DIM
14	1	TP-218021	DIN RAIL
15	4	TP-214275	STAND-OFF
16	4	TP-212247	CONNECTOR, MULTIPOLE RECTANGULAR
17	1	TP-212167	6 PIN FEMALE
18	1	TP-212229	7 PIN AMPHENOL MALE
19	1	TP-213333	3 PIN FEMALE AMPHENOL
20	1	TP-215005	SWITCH
21	1	TP-215004	SWITCH KNOB
22	4	TP-110766	1 INCH DIA. RUBBER FOOT – ¼-20 x 0.375 STUD
23	1	TP-215015	PLC ANALOG
24	1	TP-213426, TP-213427	24 VOLT POWER SUPPLY
25	1	TP-220511	PLC, FPG-C32T2H GREY
26	2	TP-214285	STAND-OFF 1-1/2" LONG 6-32
27	13	TP-208142	LARGE TERMINAL BLOCK
28	1	TP-T10MM1006	OVERLAY
29	1	TP-208141	SMALL TERMINAL BLOCK
30	1	TP-750102	SCALE CONTROLLER MO 460
31	1	TP-501111	DRIVE
32	1	TP-216160	SAFETY RELAY

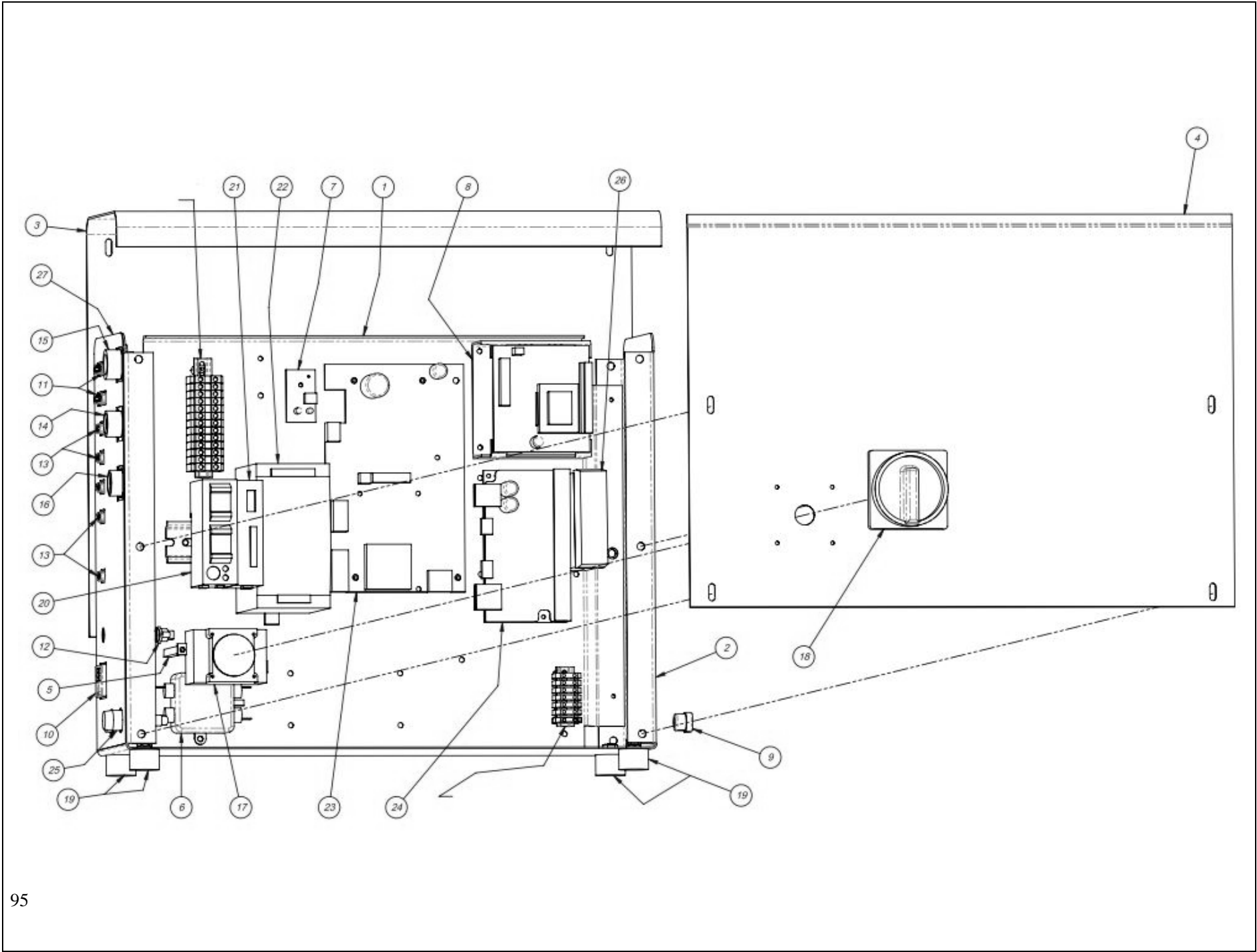



## 5.2 Touch Screen Assembly

### CUSTOM ASSEMBLY

ITEM NO.	QTY	PART NO.	DESCRIPTION
1	1	TP-T9MA3001	10" IOP HOUSING
2	1	TP-T9MA3302	BACK PLATE
3	1	TP-T1MD00039-3	INSERT COVER PLATE
4	2	TP-T1MD00109-1	IOP MOUNT
5	1	TP-T4MA5123	CLAMP BLOCK
6	1	D9-140743-1204	TOUCH SCREEN MOUNT
7	1	TP-220361	10" TOUCH SCREEN
8	2	TP-111215	JOINING TEE
9	1	TP-T1MD00109	MOUNTING BAR
10	1	D9-156415-107	LEVEL SENSOR MOUNT
11	1	D9-156415-108	LEVEL SENSOR MOUNT
12	1	D9-156415-109	LEVEL SENSOR "L" BRACKET
13	4	TP-109155	KNOB
14	1	TP-216142	PROX SENSOR

**DANCER ASSEMBLY**

PN: TA-T9-6000

**Pending**

### 5.3 Stand Assembly

---

PN: TA-T9-4000

ITEM NO.	QTY	PART NO.	DESCRIPTION
1	1	TP-T9MA4001	H-FRAME
2	4	TP-110740	SEISMIC VIBRATION DAMPENING MOUNTS
3	1	TP-T9MA4002	LOWER POST
4	1	TP-T9MA4003	BAGGER SUPPORT POST
5	1	TP-T9MA4004	INNER POST
6	1	TP-T9MA4007	TOP PLATE
7	2	TP-T9MA9001	HOPPER BLOCK

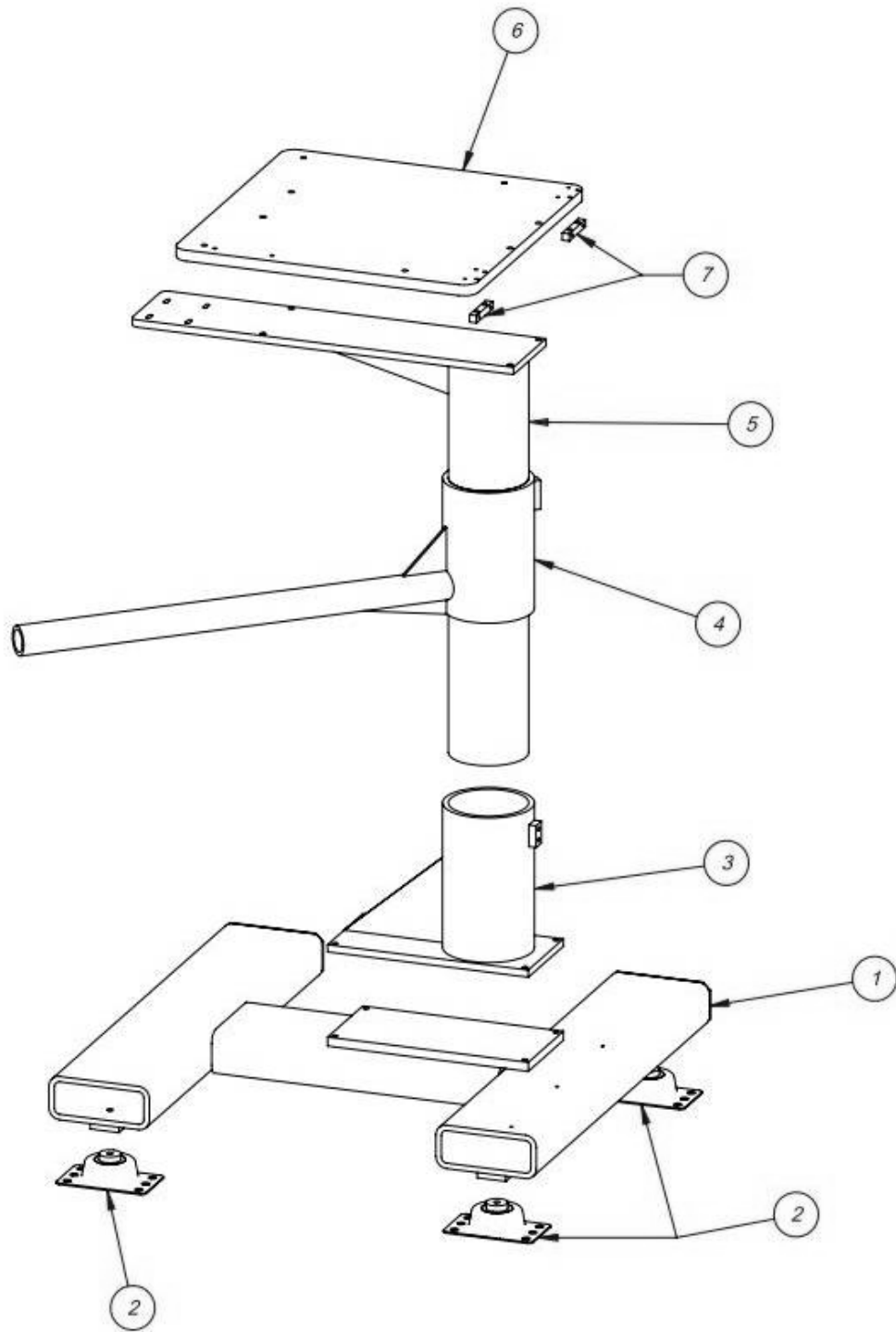

## 5.4 Scale Head Assembly

TA-T9-5000

ITEM NO.	QTY	PART NO.	DESCRIPTION
1	1	TP-T9MA5004	SCALE BASE
2	1	TP-750002	LOAD CELL
3	1	TP-T9MA5005	LOAD CELL SHROUD
4	1	TP-T9MA5006	LOAD CELL COVER
5	4	TP-110761-1	VIBRATION ISOLATOR
6	1	TP-T9MA5017	HOPPER BRACKET
7	1	TP-T9MA5009	CYLINDER MOUNT
8	1	TP-T9MA5015	CYLINDER BRACKET
9	1	TP-T9MA5020	HOPPER CLAMP
10	1	TP-T9MA5019	SCALE BASE
11	1	TP-T9MA5012	RAM
12	1	TP-403148	CYLINDER
13	1	SEE NEXT PAGE	SCALE HEAD

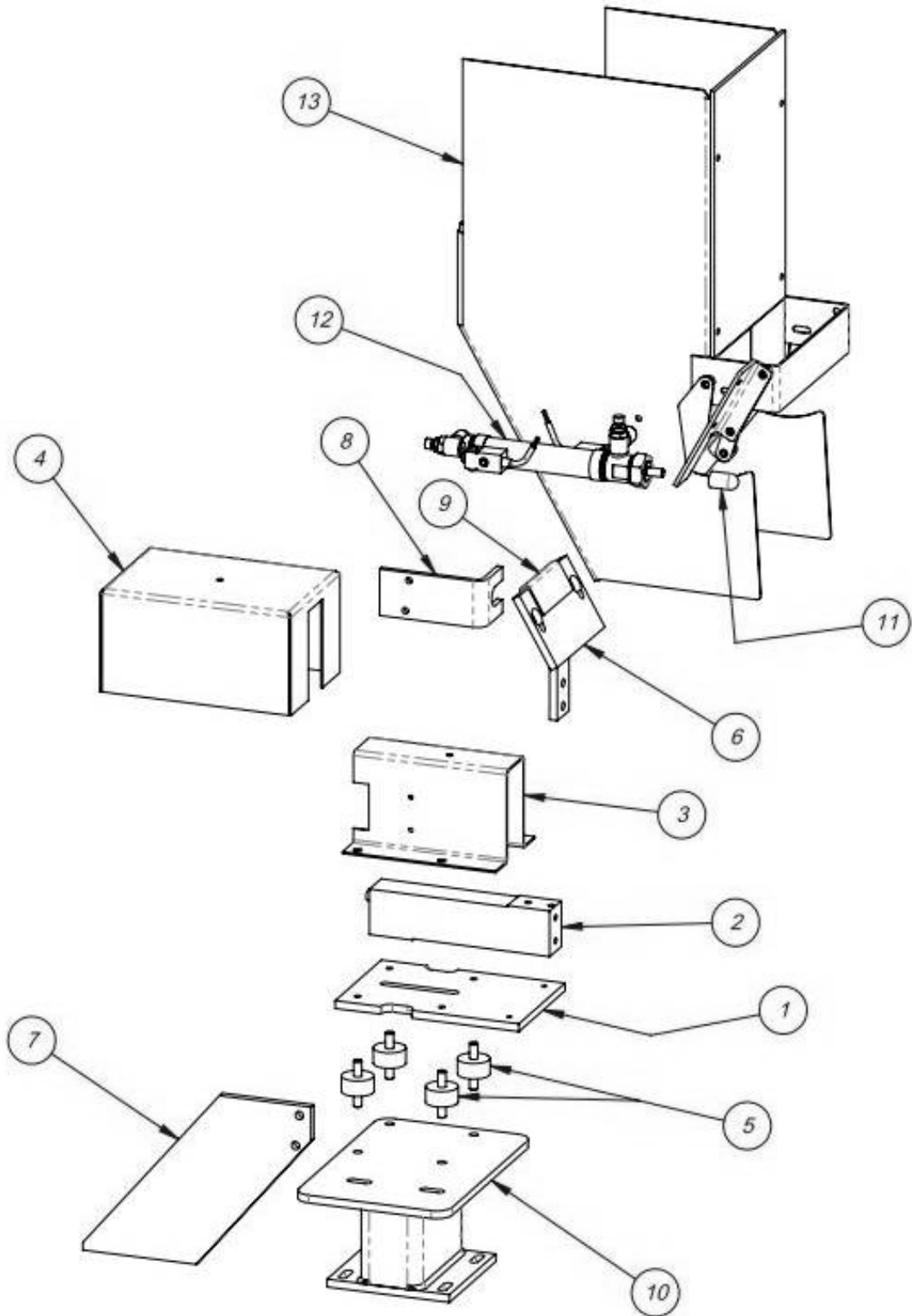

## 5.5 Dancer Assembly

PN: TA-T9-6000

ITEM NO.	QTY	PART NO.	DESCRIPTION
1	1	TP-T9MA6001	DANCER ARM (LEFT)
2	1	TP-T9MA6002	DANCER ARM (RIGHT)
3	1	TP-T1MA00073	BAG ROLL SHAFT
4	2	TP-T1MA00049	FILM TENSION HUB
5	2	TP-T9MA6003	ARM ANCHOR
6	2	TP-T9MA6004	ARM CLAMP
7	2	TP-504132	CAM FOLLOWER
8	2	TP-T1MA00072	DANCER TENSION BAR
9	1	TP-T1MA00081	DANCER TENSION BAR CROSS BRACE
10	1	TP-T9MA6004	TENSION ADJUSTER
11	2	TP-T1MA00090	DANCER GUIDE ROLLER SHAFT
12	2	TP-T1MA00089	DANCER ROLLER
13	1	VARIES PER BAG SIZE	ROLL OF BAGS

**SCALE HEAD ASSEMBLY, CONTINUED**

CUSTOM ASSEMBLY

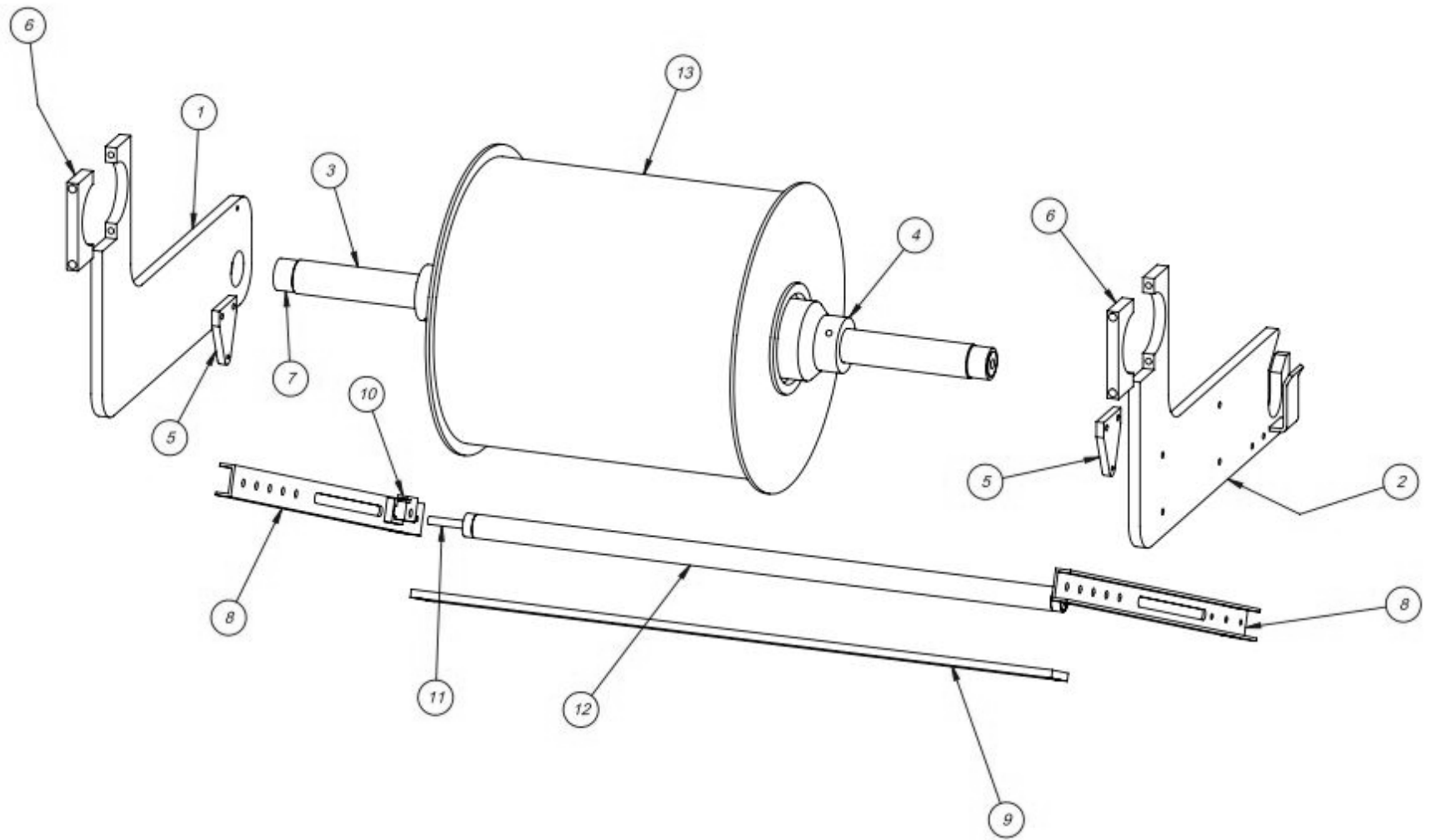



## 5.6 Bowl Assembly

TA-T9-7000

ITEM NO.	QTY	DESCRIPTION
1		
2		
3		
4		
5		
6		

**Pending, under review.**

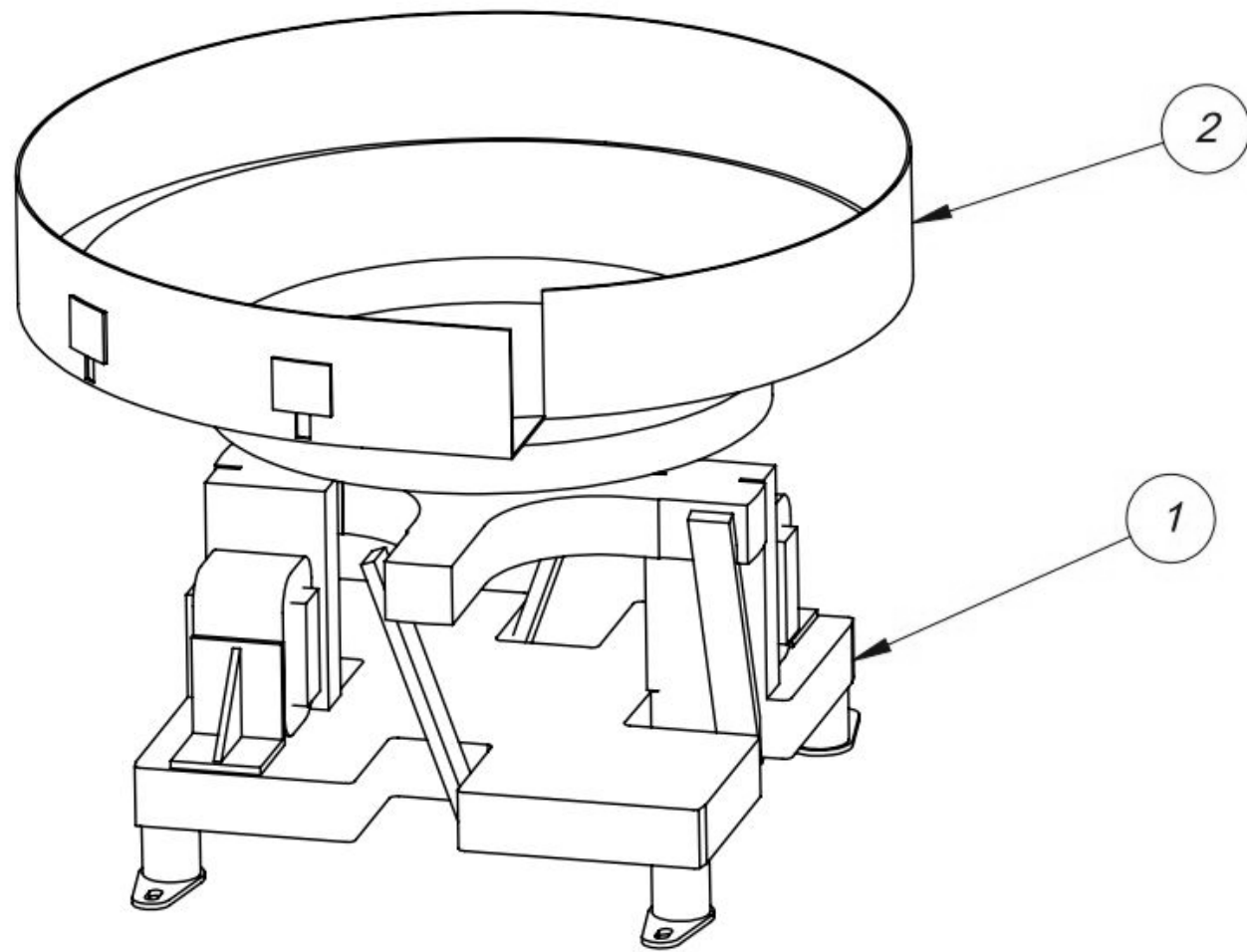

## 5.7 Chute Assembly

---

PN: TA-T9-8000

ITEM NO.	QTY	PART NO.	DESCRIPTION
1	1	TP-T9MA8001	CHUTE
2	1	TP-T9MA8002	LEXAN TOP
3	1	TP-T9MA8003	LEXAN FRONT
4	1	TP-T9MA8004	CHUTE MOUNT
5	1	TP-T9MA8005	CHUTE ADJUST MOUNT

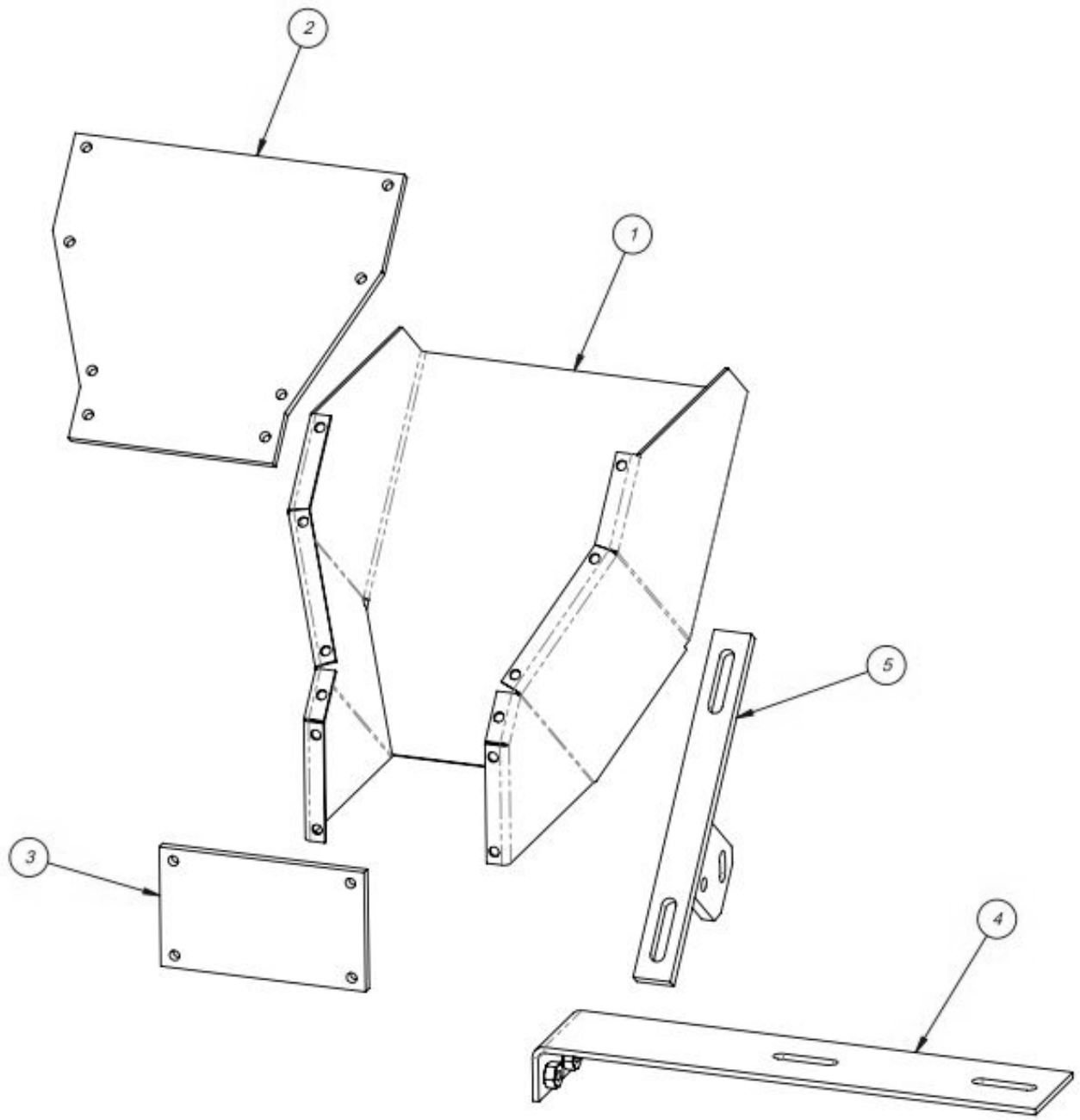

## 5.8 Supply Hopper Assembly

PN: TA-T9-9000

ITEM NO.	QTY	PART NO.	DESCRIPTION
1	1		
2	1		
3	1		
4	1		
5	1		

Pending, under review

Pending, under review.

## 5.9 Head Assembly

---

PN: TA-T10100-S14

ITEM NO.	QTY.	PART NO.	DESCRIPTION	PAGE NO.
1	1	TA-T10250-S14	MAIN FRAME ASSEMBLY	
2	1	TA-T10270-S14	ELECTRICAL PANEL	
3	1	TA-T10280-S14	SEALER FRAME ASSEMBLY	
4	1	TA-T10018	FLAT LOAD SHELF ASSEMBLY	

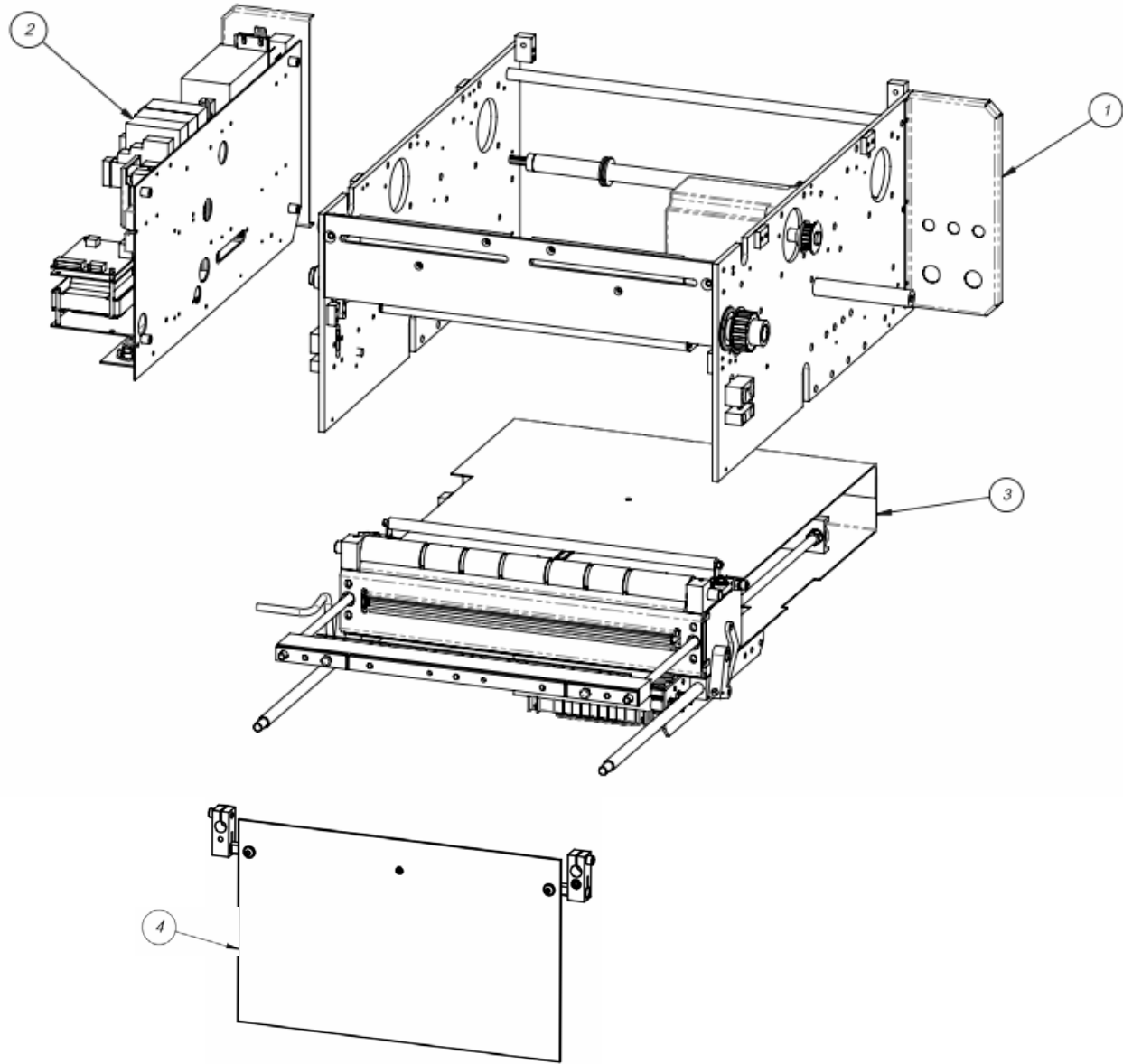



## A. Main Frame Assembly

PN: TA-T10250-S14

ITEM NO.	QTY	PART NO.	DESCRIPTION
1	2	TP-T1MC00001S14NB	SIDE FRAME
2	2	TP-T1MC00044	FACE PLATE BLOCK
3	1	TP-T1MC00042NB	FACE PLATE
4	1	TP-T1MC00079	CYLINDER PIVOT SHAFT
5	1	TP-T1MC00056	REAR CROSS SUPPORT SHAFT
6	4	TP-T1MC00054	COVER SUPPORT CLAMP
7	2	TP-T1MC00099	REAR COVER SUPPORT
8	2	TP-T1MC00058	LATCH ADJUSTER BLOCK
9	2	TP-T1MC00059	LATCH LOCK BLOCK
10	1	TP-T1MC00163-2	GUIDE BLOCK - RH
11	1	TP-T1MC00163-1	GUIDE BLOCK - LH
12	2	TP-504113	BEARING
12	1	TP-T1MC00017	RUBBER ROLLER
14	2	TP-T1MC00082	COVER STAND-OFF
15	2	TP-T1MC00052	GUIDE ROLLER
16	4	TP-106106	SPRING PINS
17	4	TP-108099	COMPRESSION SPRING, 0.040 GAUGE, 0.359 OD
18	4	TP-504101	BEARING
19	2	TP-111010	SPRING CLOSURE COLLAR
20	1	TP-501170	S14 STEPPER MOTOR
21	1	TP-T14M1027	MOTOR PULLEY
22	1	TP-T1MC00161	DRIVEN PULLEY
23	2	TP-111142	CLAMP, COLLAR
24	2	TP-215200	MAGNETIC SWITCH, T-1000-S14 MACHINE OPEN SENSOR
25	1	TP-T1MD00010S14	PNEUMATICS BACK PANEL
26	1	TA-T10002-S14	UPPER ROLLER ASSEMBLY
27	1	TP-502104	BELT 210XL037

### FLAT LOAD SHELF ASSEMBLY

TA-T10018

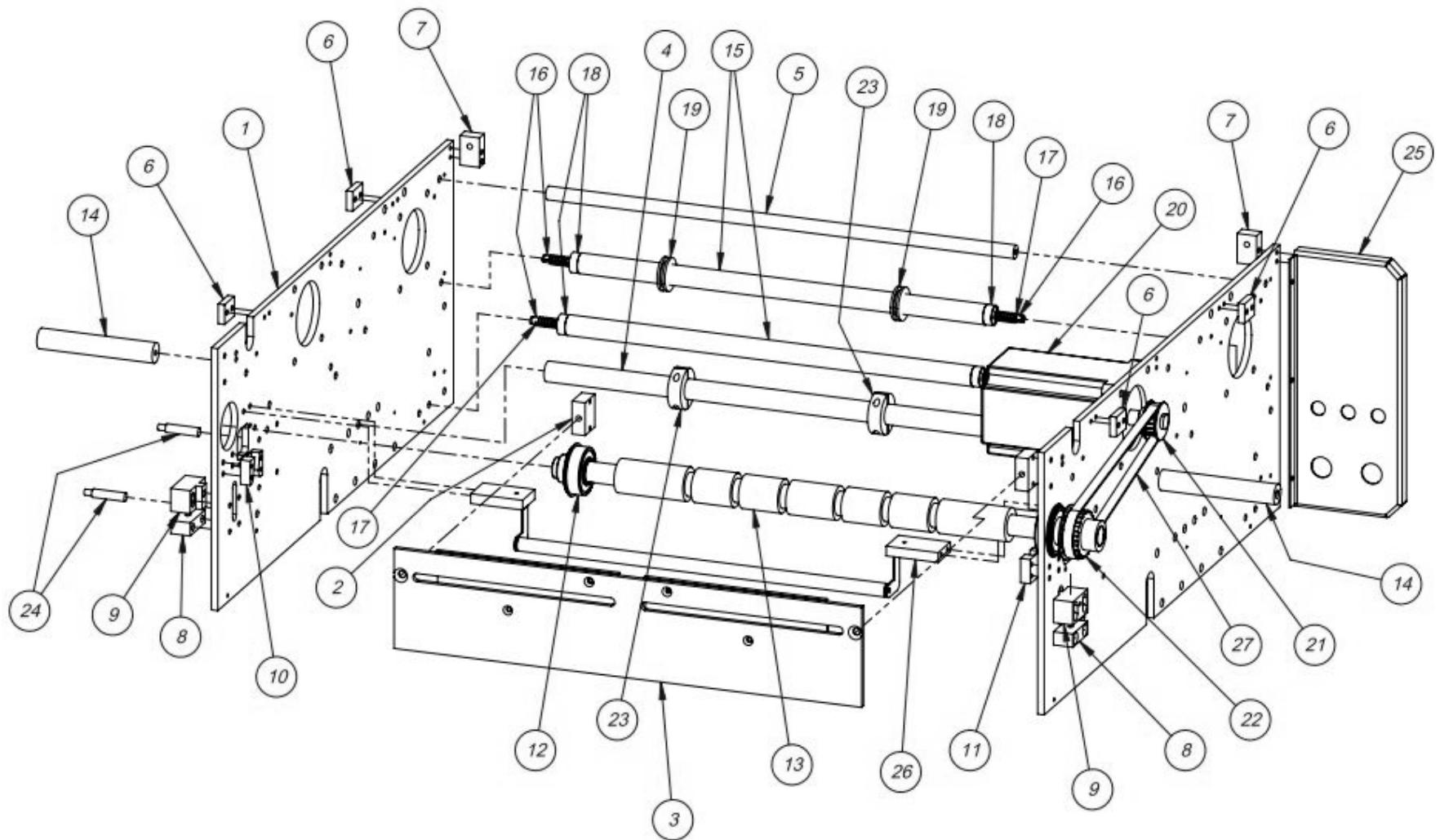

## Upper Roller Assembly

---

PN: TA-T10002-S14

ITEM NO.	QTY	PART NO.	DESCRIPTION
1	1	TP-T1MC00119	FILM WEB ROLLER
2	1	TP-T1MC00120	FILM WEB ROLLER SHAFT
3	2	TP-107177	¼ ID, 3/8 OD, 0.375 LONG BUSHING
4	2	TP-T1MC00018S14	ROLLER MOUNT
5	1	TP-T1MC00118-1	FILM WEB ROLLER BRACKET LEFT
6	1	TP-T1MC00118-2	FILM WEB ROLLER BRACKET RIGHT

## MAIN FRAME ASSEMBLY

---

PN: TA-T10250-S14

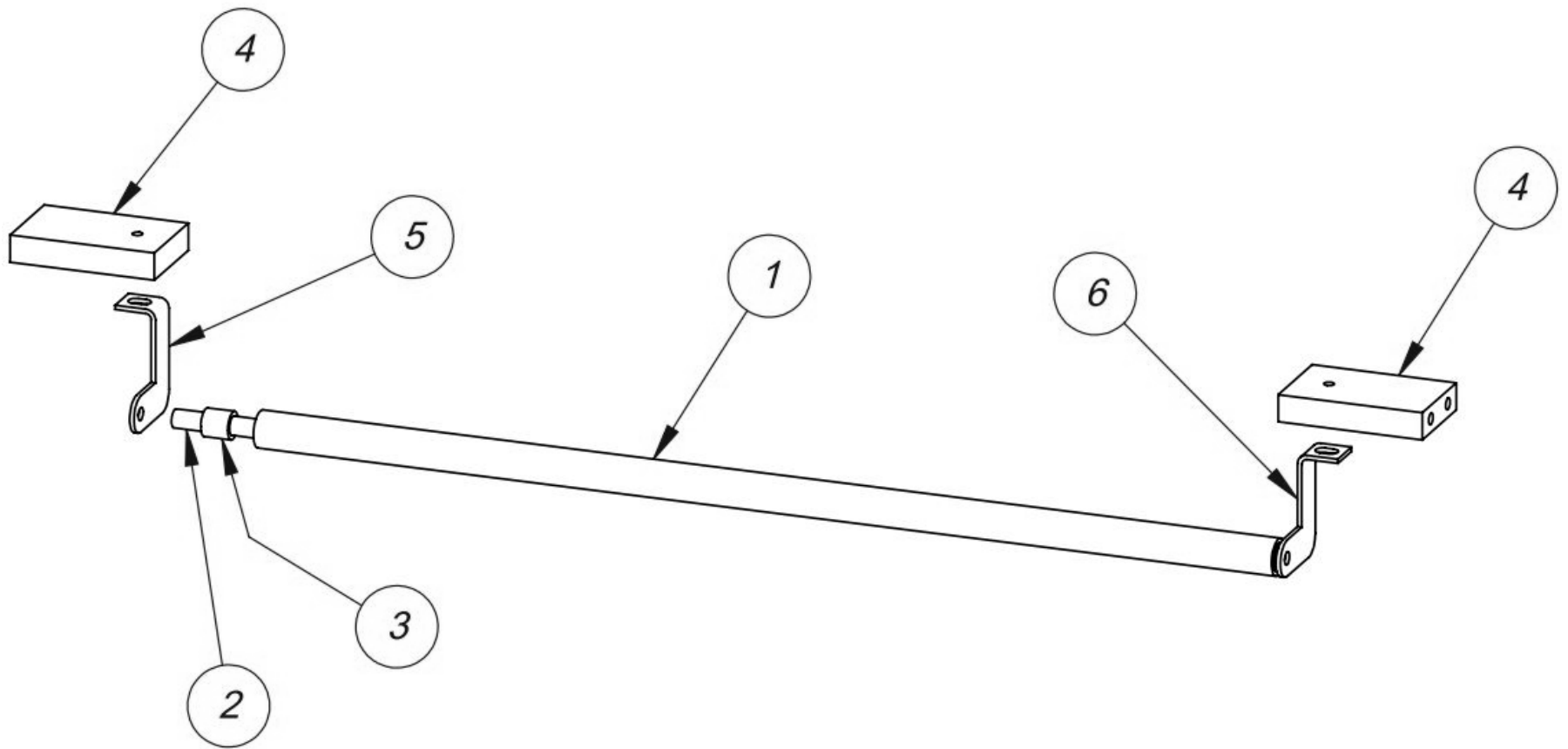

## B. Electrical Panel

PN: TA-T10270-S14

ITEM NO.	QTY	PART NO.	DESCRIPTION
1	1	TP-T1MC00006-S14	ELECTRONICS MOUNTING PANEL
2	1	TP-205108	EMI FILTER, CORCOM
3	1	TP-207216, TP-207344	FUSE HOLDER AND FUSE
4	1	TP-212167	6 PIN CIRCULAR FEMALE
5	2	TP-212247	9 PIN D-SUB FEMALE
6	1	TP-212410	AC OUTLET
7	1	TP-213361	24VDC, 3 AMP POWER SUPPLY
8	1	TP-215000	SOLID STATE RELAY
9	1	TP-215000A	COVER
10	1	TP-211386	HIGH VOLTAGE TRANSFORMER
11	1	TP-215384	POWER SWITCH
12	1	TP-501169-1	5 PHASE DRIVER
13	4	TP-214268	STAND-OFF 0.38"
14	1	TP-215004	SWITCH KNOB
15	1	TP-215005	SWITCH
16	1	TP-T1MC00021	TRANS MOUNTING PLATE
17	1	TP-212160	5 POS MINI DIM
18	1	TP-T1MC00002S14	ANGLE MOUNT (5) PHASE DRIVER
19	1	TP-T1MC00016S14	ELECTRONICS MOUNTING BRACKET
20	1	TP-212248	25 PIN D-SUB FEMALE
21	1	TP-220511, TP-214111, TP-220513	PLC, BATTER AND COMM 2 CAS
22	1	TP-220514	PLC, FPO-E32T-A EXPANSION I/O
23	1	TP-T1MO00228	T-1000-S14 EURO DISCONNECT SWITCH MOUNTING PLATE
24	2	TP-T1MO00229	STANDOFF
25	1	TP-212166	6 PIN MALE
26	1	TP-212338	10 PIN FEMALE
27	1	TP-220508	PLC ANALOG MODULE
28	1	TP-212242	3 PIN SOCKET WITH ANGLE BRACKET
29	1	TP-215115, TP-215116	AUX RELAY AND SOCKET
30	1	TP-112242	POWER DIST. STRAIN RELIEF, 7/8 HOLE
31	1	TP-218020	DIN RAIL
32	1	TP-218021	DIN RAIL
33	2	TP-214279	STANDOFF 1"
34	19	TP-208142	LARGE TERMINAL BLOCK

### UPPER ROLLER ASSEMBLY

PN: TA-T10002-S14

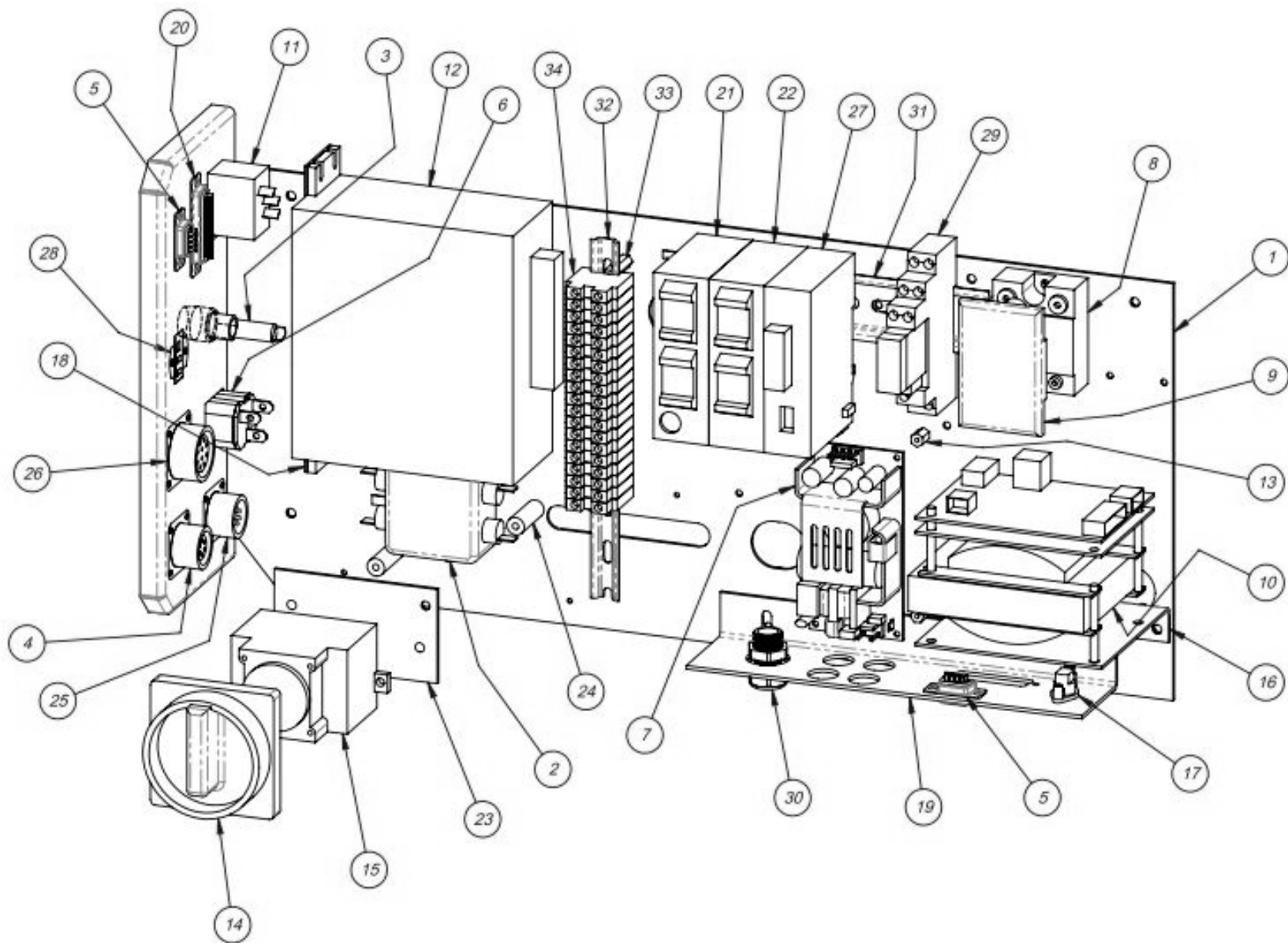

## C. Sealer Frame Assembly: Drop Frame

PN: TA-T10280-S14

ITEM NO.	QTY	PART NO.	DESCRIPTION
1	1	TP-403244	CYLINDER
2	1	TA-T10005	PRESSURE BAR SUBASSEMBLY
3	1	TA-T10006	HEATER BAR SUBASSEMBLY
4	1	TA-T10009	PTFE GUIDE SUBASSEMBLY
5	1	TA-T10012	GROOVED ROLLER MOUNTING SUBASSEMBLY
6	2	TP-403245	CYLINDER
7	2	TA-T10019	LATCH SUBASSEMBLY
8	1	TP-T1MB00005	FRONT GRIPPER PLATE
9	1	TP-T1MB00010	SEALER ROD TIE
10	1	TP-T1MB00016	SEAL CYLINDER MOUNTING BLOCK
11	2	TP-T1MB00022	GUARD ROD MOUNTING BLOCK
12	2	TP-104210	SPACER 3/8LG, 1/2 DIA, 0.252 HOLE
13	2	TP-T1MB00033	SEAL GUIDE ROD
14	2	TP-T1MB00057	HEATER BAR YOKE
15	1	TP-T1MB00062	L.H. LATCH HANDLE
16	1	TP-T1MB00063	LATCH SHAFT
17	1	TP-T1MB00107	MAGNETIC SENSOR HOUSING
18	2	TP-T1MB00144-1	SHIELD MOUNTING ROD
19	1	TP-T1MB00164	PIVOT CLAMP
20	1	TP-T1MB00200	SEALER FRAME
21	1	TP-T1ME00209	SEAL BAR COIL CABLE (NOT SHOWN)
22	4	TP-107160	PTFE COATED BUSHING
23	2	TP-107227	BUSHING, THRUST NYLON
24	2	TP-107228	BUSHING, NYLON FLANGE
25	3	TP-211374	MAGNET, ROUND
26	1	TP-T1MD00275NB-1	BOTTOM INTERNAL GUARD
27	1	TP-T1MD00276NB-1	NBO INTERNAL GUARD
28	2	TP-402186	FLOW CONTROL, #10-32
29	2	TP-401277	ELBOW 1/4" TUBE x #10-32
30	2	TP-107127-1	BRONZE BUSHING
31	2	TP-401257	ELBOW 1/4" TUBE x 1/8 NPT
32	2	TP-T1MB00027	GRIPPER SPACER
33	2	TP-T1MO00023	DROP FRAME SPACER
34	1	TP-T1MO00129	DROP FRAME FACE PLATE
35	1	TA-T10020-S14	MANIFOLD ASSEMBLY
36	1	TA-T10017	BAG FINGER GROUNDING ASSEMBLY
37	1	TP-403507	SEAL FRAME STRUT

*NOTE: If you purchased the T-1000-S14 with a Standard Frame instead of a Drop Frame, your part numbers for the Standard Sealer Frame Assembly are the same as those listed above, with the exception of Item 12 TP-104210*

### **SEALER FRAME ASSEMBLY: DROP FRAME**

PN: TA-T10280-S14





*Spacer, Item 33 TP-T1MB00023 Drop Frame Spacer and Item 34 TP-T1MO00129 Drop Frame Face Plate. Those three parts are not included in the Standard Frame Sealer Frame Assembly.*

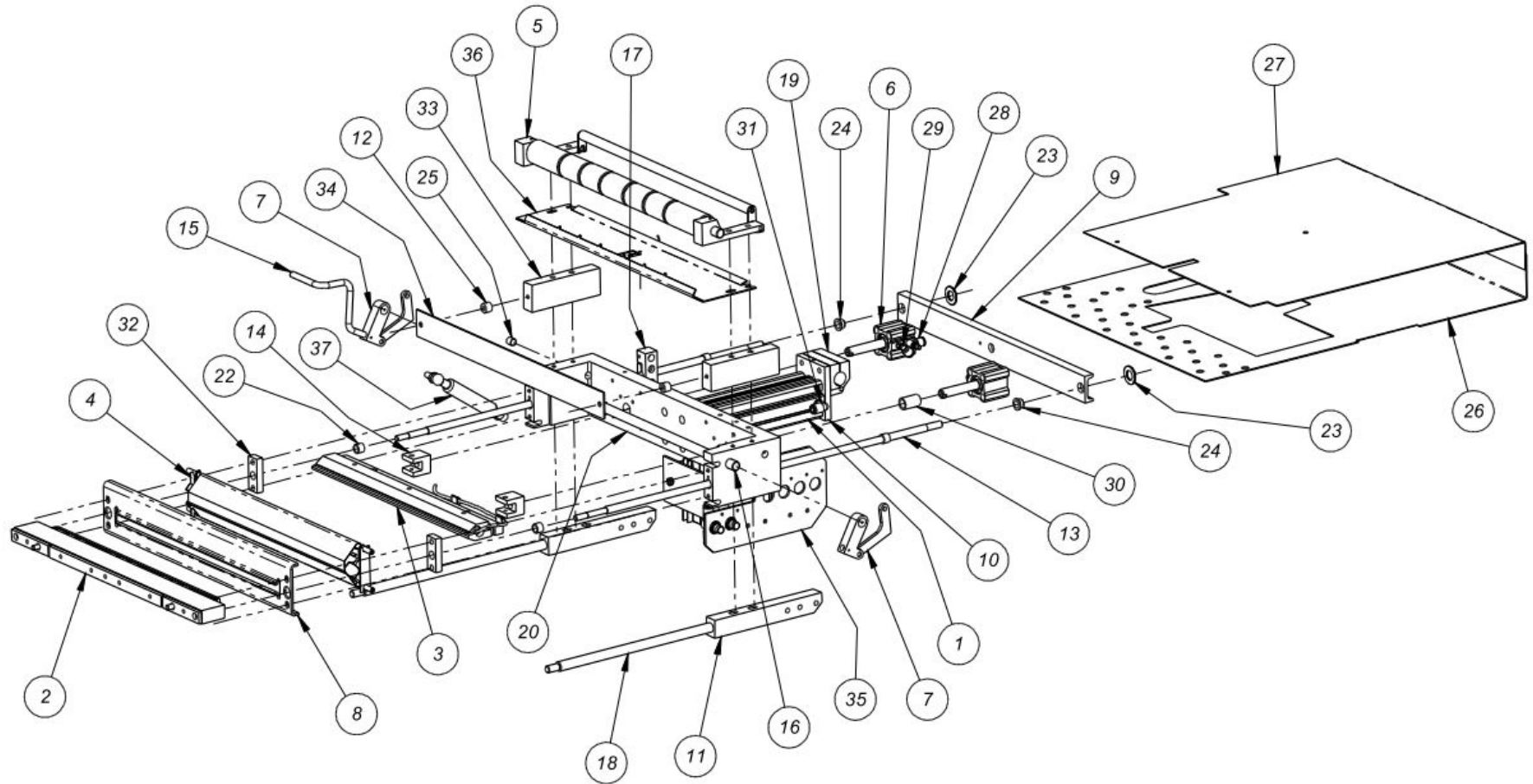

*NOTE: Items 26 and 27 shown above are used in baggers with a 5.25" bag pass through. For baggers with a 4.25" bag pass through, Item 26 will be TP-T1MD000275 and Item 27 will be TP-T1MD000276. For baggers with a 6.25" bag pass through, Item 26 will be TP-T1MD000275-2 and Item 27 will be TP-T1MD000276-2. For baggers with a 7.25" bag pass through, Item 26 will be TP-T1MD000275-3 and Item 27 will be TP-T1MD000276-3.*

## Pressure Bar Subassembly

PN: TA-T10005

ITEM NO.	QTY	PART NO.	DESCRIPTION
1	1	TP-T1MB00029	ANTI-JAM PRESSURE HOUSING
2	1	TP-T1MB00030	ANTI-JAM CONTACT STRIP
3	1	TP-T1MB00031	ANTI-JAM PRESSURE PAD
4	2	TP-T1MB00068	ANTI-JAM CONTACT STRIP
5	1	TP-T1MB00111	RUBBER STRIP HOLDER
6	1	TP-306002	RUBBER SEAL
7	4	TP-300001	RUBBER BUMPER
8	2	TP-106093	¼ - 20 x 2" STUD
9	2	TP-108155	COMPRESSION SPRING

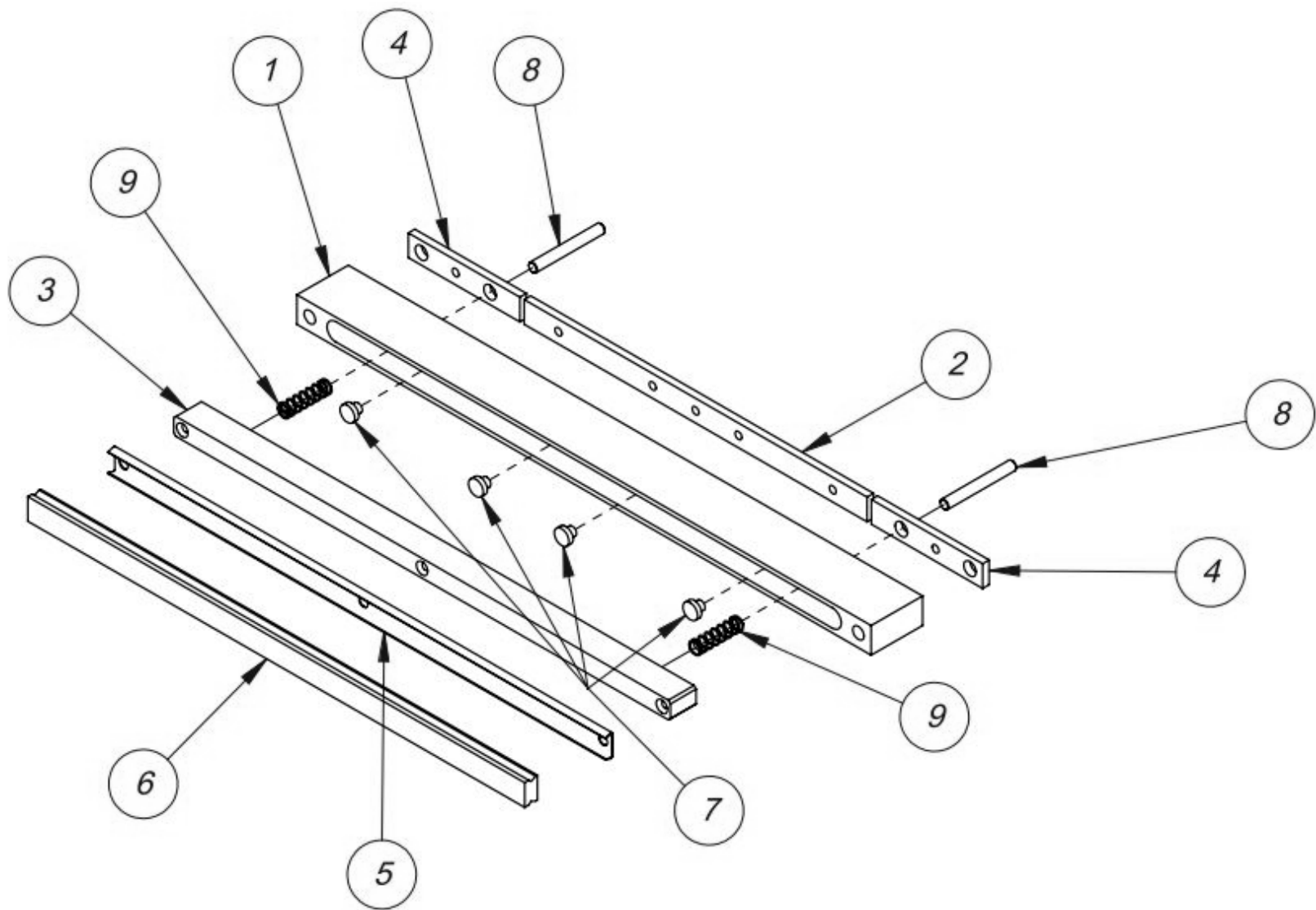

**PRESSURE BAR SUBASSEMBLY**  
PN: TA-T10005

## Heater Bar Subassembly

PN: TA-T10006

ITEM NO.	QTY	PART NO.	DESCRIPTION
1	1	TP-T1MB00008	HEATER BAR MOUNTING PLATE
2	1	TP-T1MB00009-1	1/8" SEAL BAR*
3	1	TP-T1MB00006	HEATER BAR CLAMP
4	1	TP-T1MB00024	HEATER CARTRIDGE CORNER HANGER
5	1	TP-T1MB00145	WIRE TIE DOWN
6	1	TP-T1MB00159	HEATER CARTRIDGE WIRE LEAD CLAMP
7	4	TP-104124	SPACER
8	1	TP-217116	CARTRIDGE, HEATER
9	1	TP-221416	THERMAL-COUPLE WIRE

*\*NOTE: Depending on your order, Item 2 could also be TP-T1MB00009 Heater Seal Bar, TP-T1MB00009-2 1/4" Seal Bar, TP-T1MB00009-3 Three Point Seal or TP-T1MB00009-5 3/8" Seal Bar.*

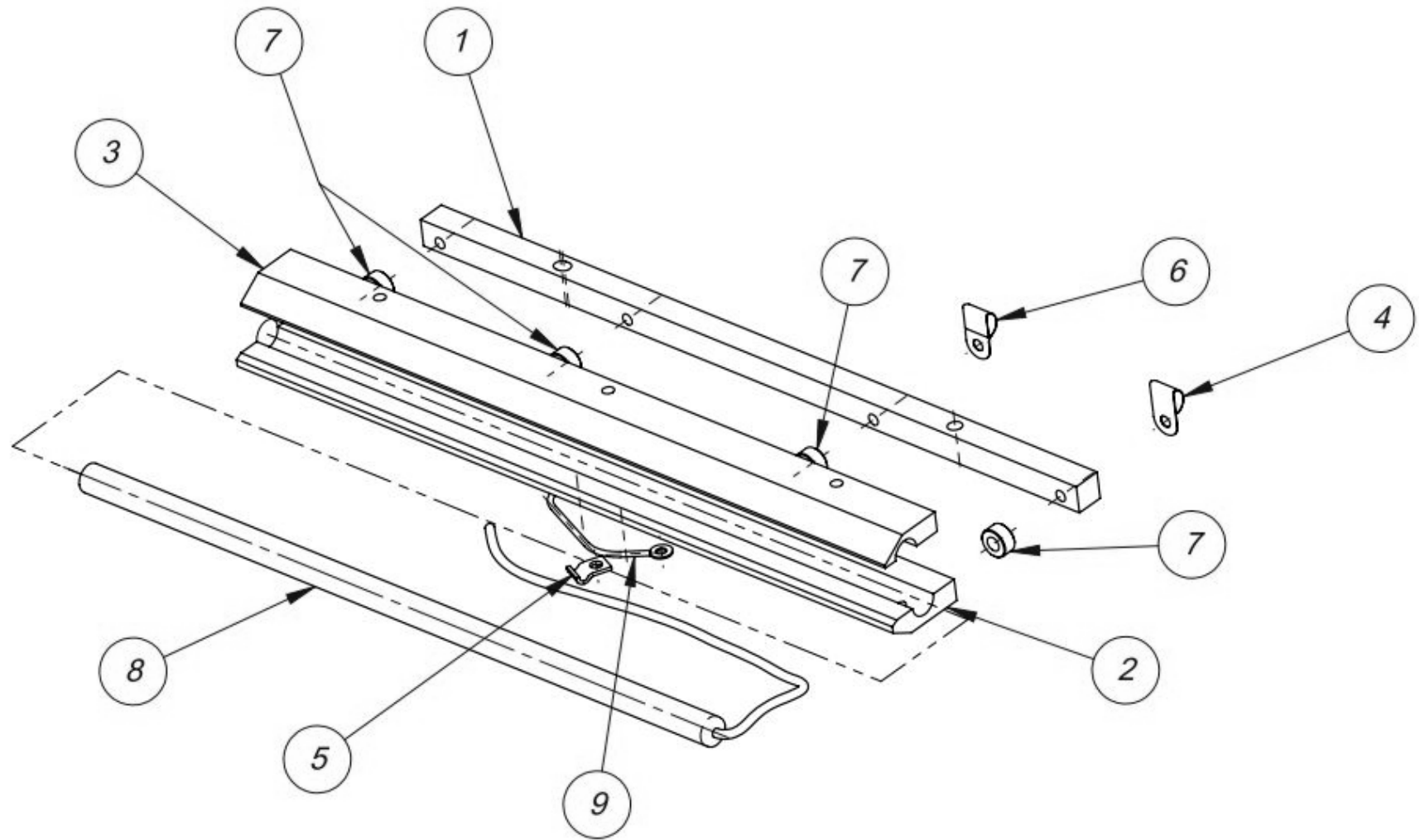

**HEATER BAR SUBASSEMBLY**  
PN: TA-T10006

## PTFE Guide Subassembly

PN: TA-T10009

ITEM NO.	QTY	PART NO.	DESCRIPTION
1	1	TP-T1MB00034	PTFE FINGER
2	2	TP-T1MB00040	PTFE ROD
3	2	TP-108089	EXTENSION SPRING
4	1	TP-300500	PTFE

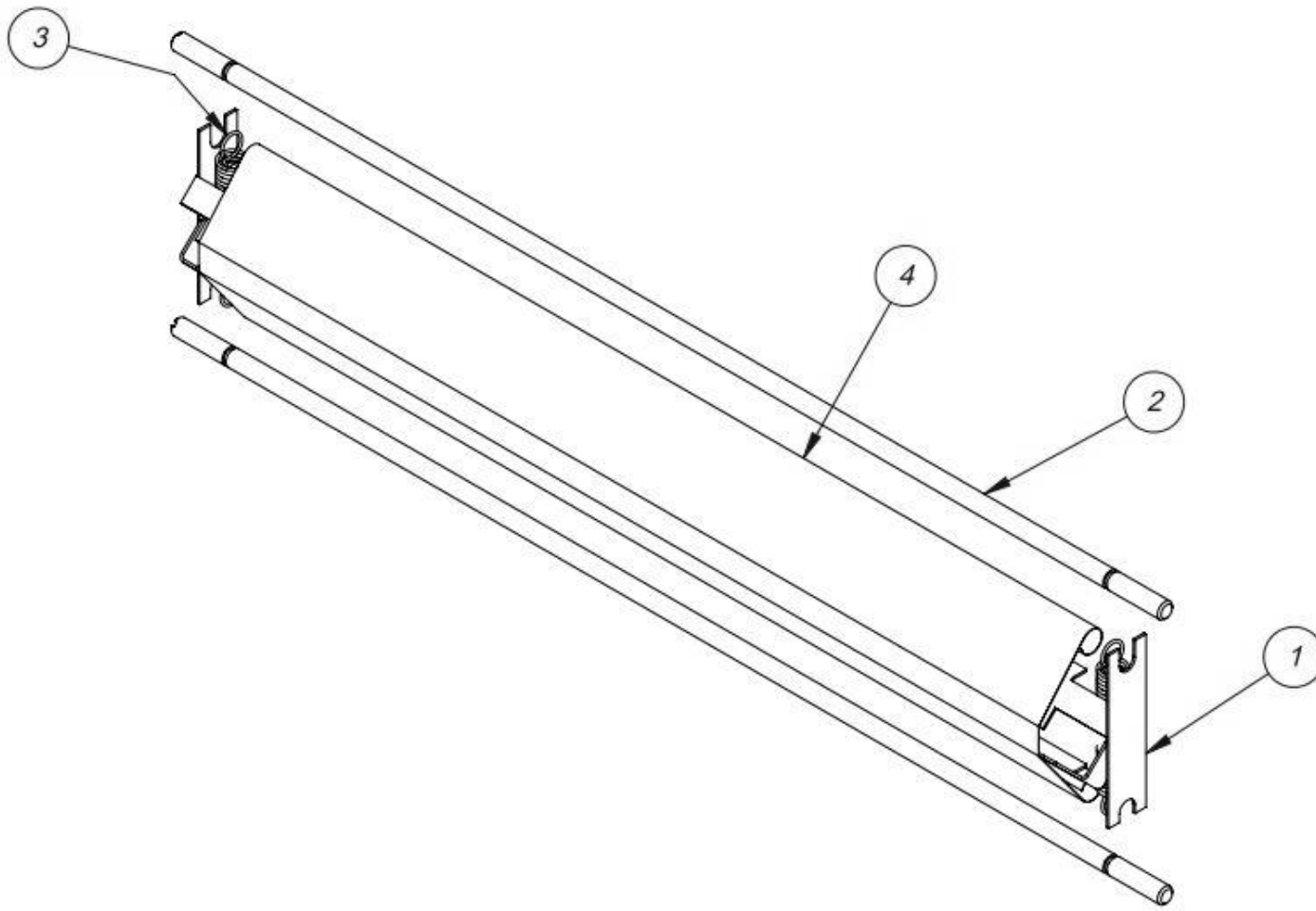



## Grooved Roller Mounting Subassembly

---

PN: TA-T10012

ITEM NO.	QTY	PART NO.	DESCRIPTION
1	1	TP-T1MB00013	ALUMINUM ROLLER SHAFT
2	2	TP-T1MB00004NB	ROLLER MOUNTING BLOCK
3	1	TP-T1MB00012	ROLLER
4	2	TP-107227	BUSHING, THRUST NYLON
5	2	TP-504107	BEARING, 0.500 BORE, 1.125 OD, 9/32 WIDE
6	1	TP-T1MB00155	FILM WEB TENSION ROLL
7	1	TP-T1MB00156	FILM WEB TENSION SHAFT
8	2	TP-T1MC00121	REAR ROLLER CLIP
9	2	TP-107163	¼ ID x 3/8 x 0.250 BUSHING

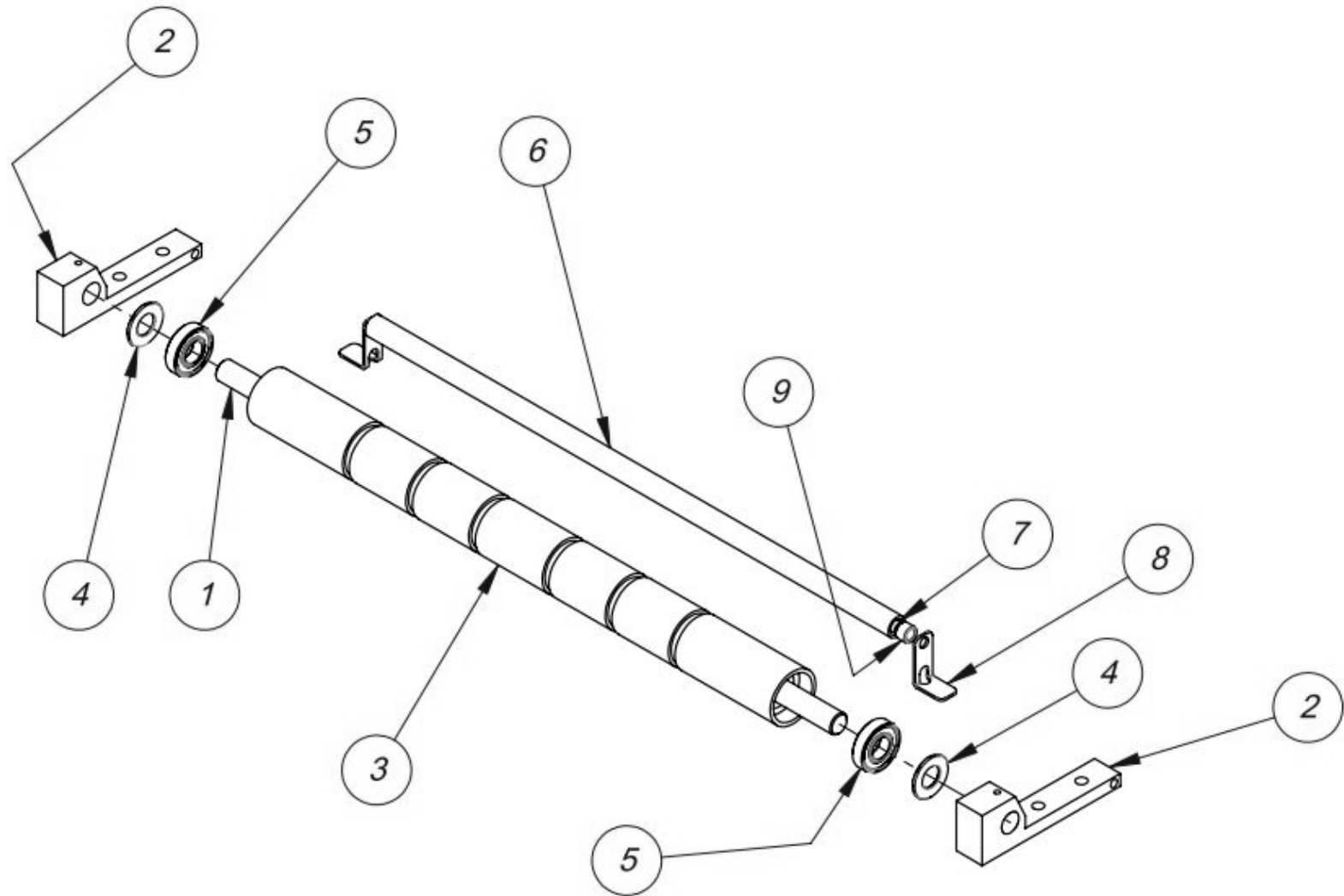

**GROOVED ROLLER MOUNTING SUBASSEMBLY**  
PN: TA-T10012

## Bag Finger Grounding Subassembly

---

PN: TA-T10017

ITEM NO.	QTY	PART NO.	DESCRIPTION
1	1	TA-T100124-3	GROUNDING SENSOR
2	1	TP-T1MB00028	GROOVED METAL ROLLER FINGER
3	1	TP-T1ME00325	GROUNDING SENSOR WIRE ASSEMBLY

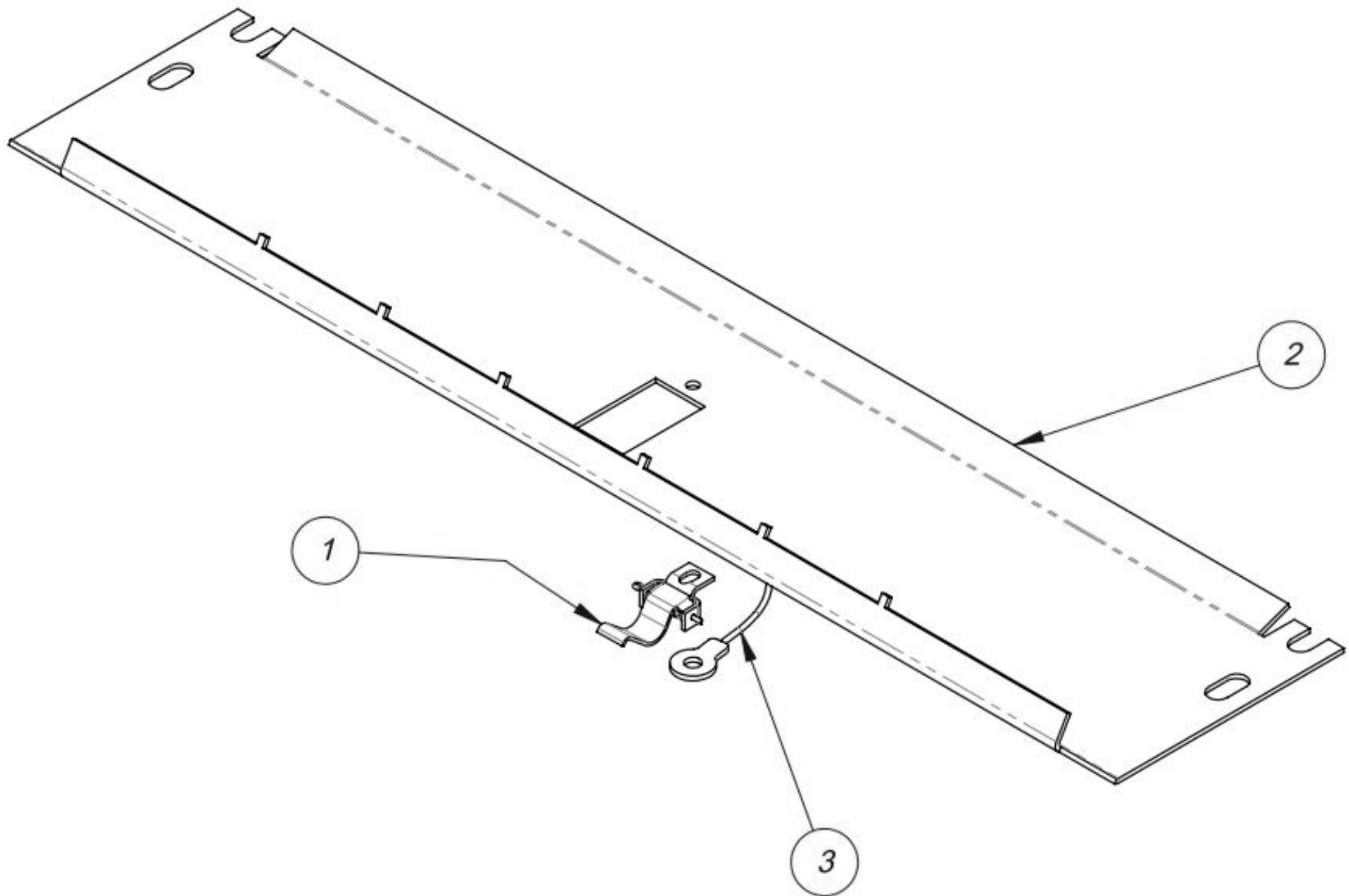

**BAG FINGER GROUNDING SUBASSEMBLY**  
PN: TA-T10017

## Latch Subassembly

---

PN: TA-T10019

ITEM NO.	QTY	PART NO.	DESCRIPTION
1	1	TP-T1MB00060	LATCH LOCK
2	1	TP-T1MB00061	LATCH CAM
3	1	TP-106135	DOWELL PIN

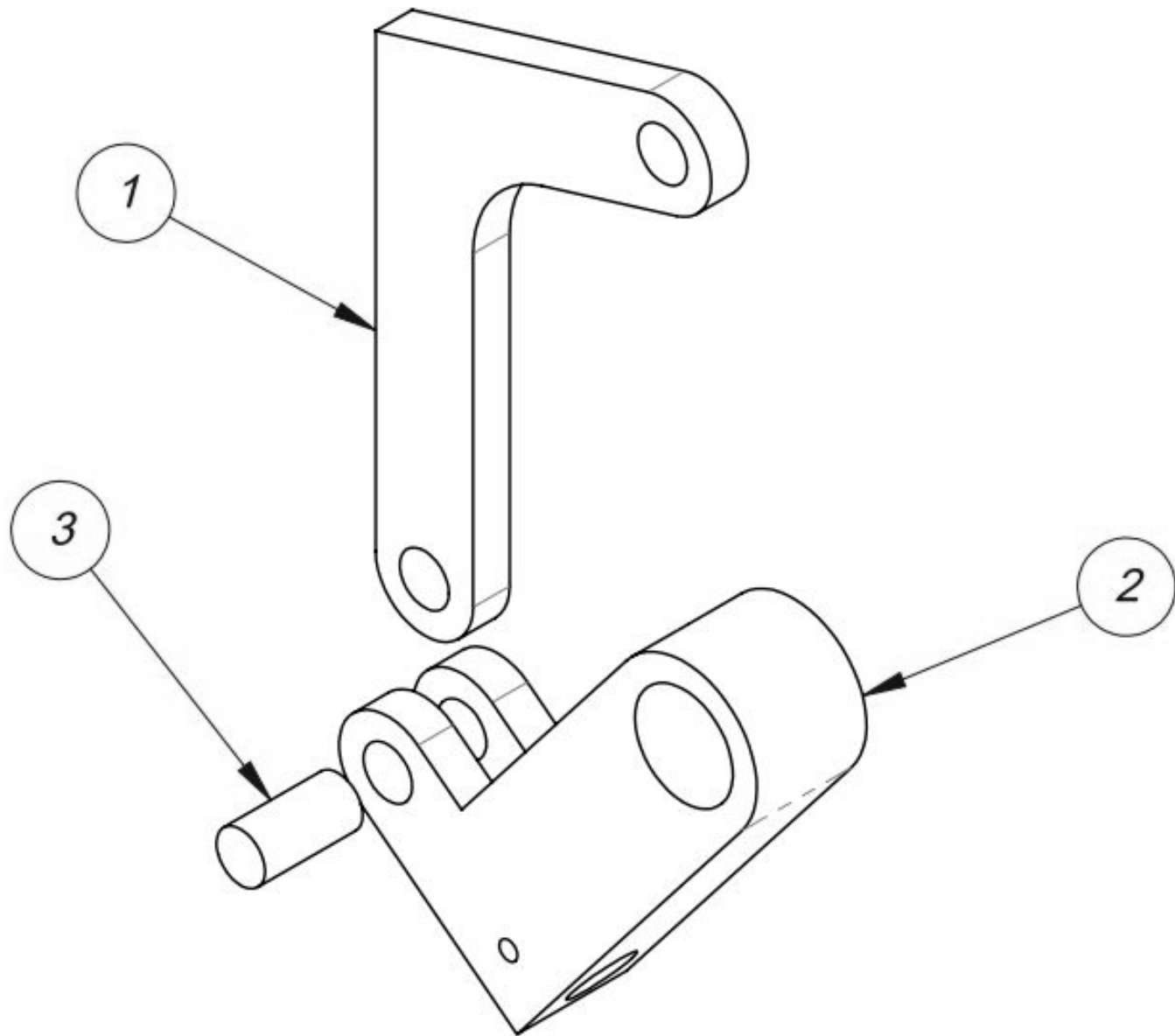

**LATCH SUBASSEMBLY**  
PN: TA-T10019

## Manifold Subassembly

---

PN: TA-T10020-S14

ITEM NO.	QTY	PART NO.	DESCRIPTION
1	1	TP-T1MC00015S14	MANIFOLD BRACKET
2	2	TP-402104	IN-LINE FLOW CONTROL, AS2051F-07
3	1	TA-T10025-S14	PNEUMATIC VALVE ASSEMBLY

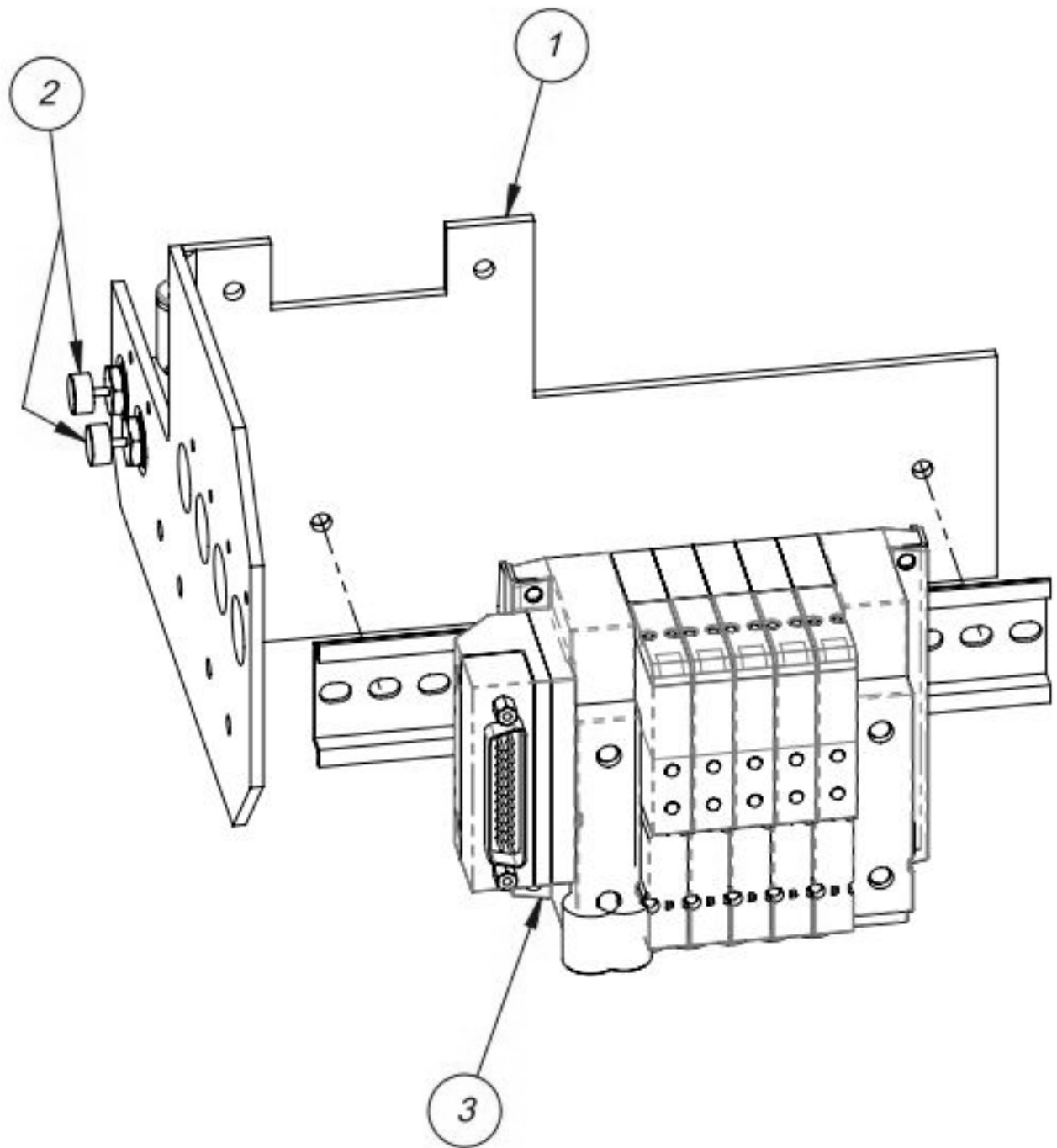



## D. Flat Load Shelf Assembly

---

PN: TA-T10018

ITEM NO.	QTY	PART NO.	DESCRIPTION
1	1	TP-T1MB00074-2	LOAD SHELF BRACKET (RIGHT)
2	1	TP-T1MB00074-1	LOAD SHELF BRACKET (LEFT)
3	1	TP-T1MB00075	9" FIXED LOAD SHELF
4	1	TP-T1MB00076	LOAD SHELF ROD

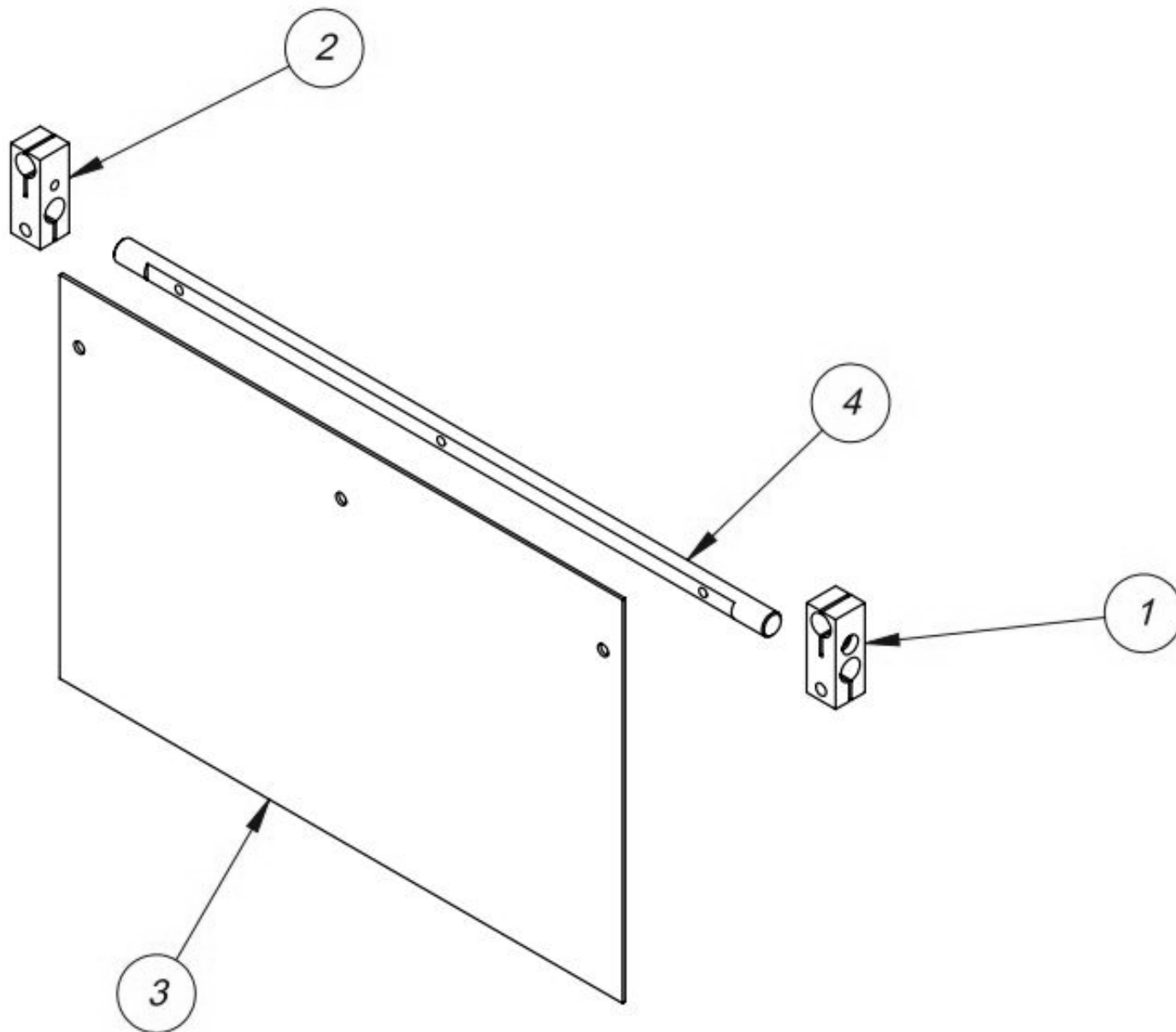

**FLAT LOAD SHELF ASSEMBLY**  
TA-T10018

## **E. E-STOP Assembly**

---

### OPTIONAL ASSEMBLY

ITEM NO.	QTY	PART NO.	DESCRIPTION
1	1	D9-156415-206	E-STOP MOUNT
2	1	TO-T1-ES10	E-STOP SWITCH

