

# US-5500 Semiautomatic “Kit” Net-Weigh / Counting Scale With Partition “Light” Table

---

Operation Guide, Version 3

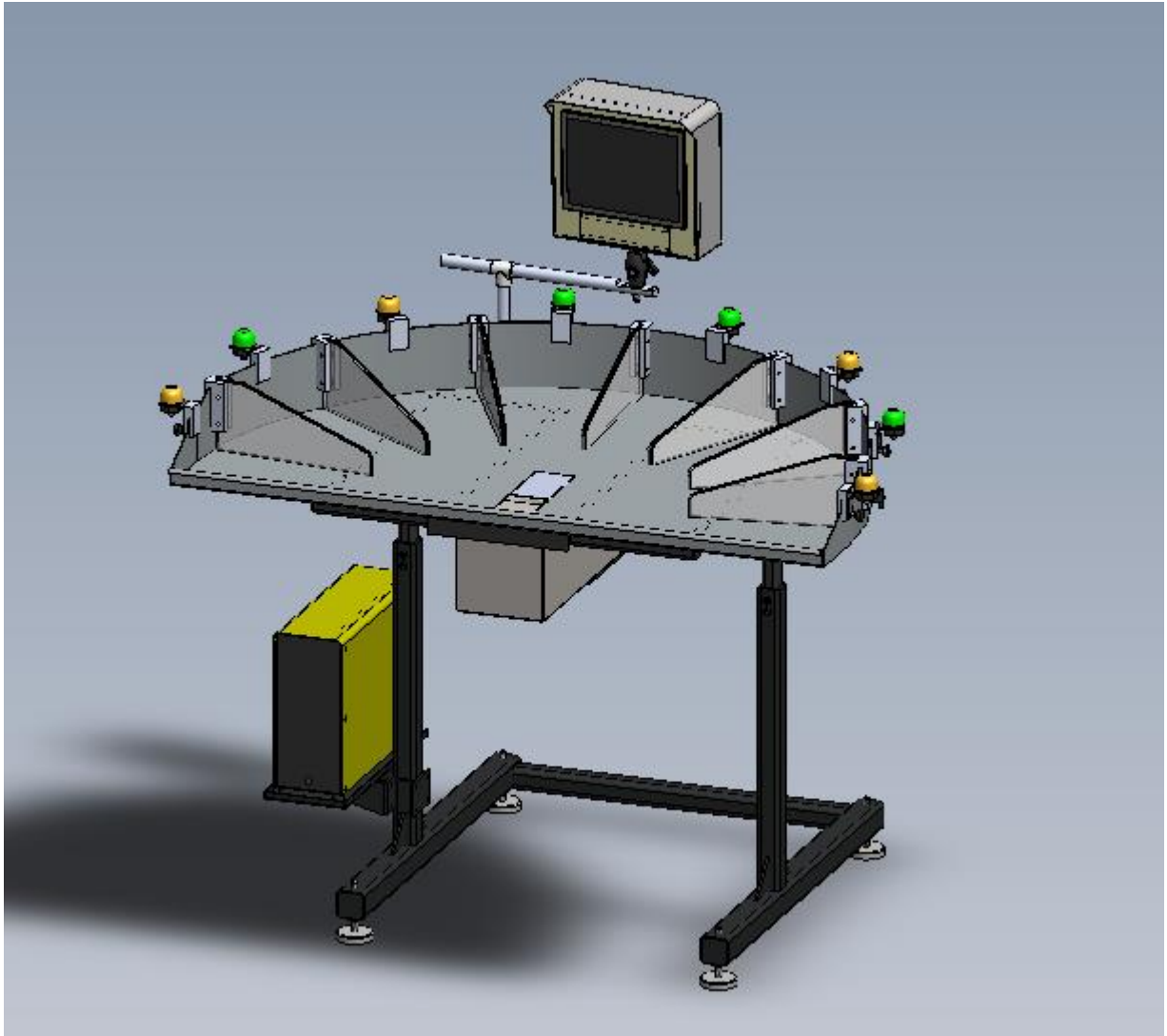

 **Advanced  
Poly-Packaging, Inc.**

1331 Emmitt Road • Akron, OH 44306 • 1-800-754-4403 • fax 330-785-4010 • [www.advancedpoly.com](http://www.advancedpoly.com)

## Acknowledgments

---

Written By: Annie Braddock

Reviewed By: Stuart Baker

## Copyright

---

Version 3 (2014), Version 2 (2006), Version 1 (2001) Advanced Poly-Packaging, Inc. (APPI). All rights reserved.

This manual and the program operating the equipment described in it are copyrighted. You may not copy this manual in whole or part without the consent of Advanced Poly-Packaging, Inc.

All information pertaining to the promotion, sale, distribution, operation and maintenance of the T-1000 ADVANCED POLY-BAGGER including this manual, drawings, schematic, wiring diagrams, VHF video tapes, brochures, specification sheets, figures, charts, or any other information, due to its proprietary design and manufacture remain the property of Advanced Poly Packaging, Inc. Unauthorized duplication, distribution or disclosure to third parties without the express permission of Advanced Poly-Packaging, Inc. is strictly prohibited.

## Trademarks

---

Ultra-Scale is a trademark of Advanced Poly-Packaging, Inc. Advanced Poly-Packaging, Inc. owns also the following trademarks: T-1000, Advanced Poly-Bags, Advanced Poly-Bagger, Seal-a-Print, Roll-a-Print, Twin-Seal, Advanced Poly-Pack, Advanced Poly-Bag, Advanced Bag.

## Limited Warranty and Disclaimer

---

Warranty period is 12 months or 1,000,000 cycles whichever comes first. The warranty commences on the date of delivery of the equipment to the Purchaser. APPI warrants to the Purchaser that the equipment is free from defects in workmanship or material under normal use and service. During the warranty period, APPI agrees to repair or replace, at its sole option, without charge to Purchaser, any defective component part of the equipment. To obtain service, Purchaser must return the equipment or component to APPI or an authorized APPI distributor or service representative in an adequate container for shipping. Any APPI. Accordingly, additional statements such as dealer advertising or presentations, whether oral or written, do not constitute warranties by APPI and should not be relied upon. Warranty on equipment is considered void when outstanding balances become delinquent (over 30 days late - 60 days after ship date). Equipment Integration to other Equipment: APPI assumes no responsibility for the integration of its products to other products or within a system unless APPI performs the integration, testing and provides the results of the tests to the purchaser in writing. Furthermore, APPI assumes no responsibility for bag sizing whether suggested or recommended. Shipping charges, insurance, or other fees must be paid by Purchaser and all risk for the equipment shall remain with Purchaser until such time as APPI takes receipt of the equipment. Upon receipt, APPI, the authorized distributor or service representative will promptly repair or replace the defective component and then return the equipment or component to Purchaser, shipping charges, insurance and additional fees prepaid. APPI may use reconditioned or like new parts or units, at its sole option, when repairing any component or equipment. Repaired products shall carry the same amount of outstanding warranty as from original purchase. Any claim under the warranty must include a dated proof of delivery. In any event, APPI's liability for defective components or equipment is limited to repairing or replacing the components. This warranty is contingent upon proper use of the equipment by Purchaser and does not cover: expendable component part such as thermocouple wire, heater cartridge, rollers, bushings, and the like; or if damage is due to accident, unusual physical, electrical or electromechanical stress, neglect, misuse, failure of electric power, water damage (from airlines), improper environmental conditions, transportation, tampering with or altering of the equipment, packaging of corrosive or contaminating products or other products damaging to components, and equipment or components not owned or in the possession of original Purchaser. APPI will not be liable for loss of production, profits, lost savings, special, incidental, consequential, indirect or other similar damages arising from breach of warranty, breach of contract, negligence, or their legal action even if APPI or its agent has been advised of the possibility of such damages or for any claim brought against the Purchaser by another party. This warranty allocates risks of equipment failure between Purchaser and APPI. APPI's pricing reflects this allocation of risk and the limitations of liability contained in this warranty. The warranty set forth above is in lieu of all other express warranties, whether oral or written. The agents, employees, distributors and dealers of APPI are not authorized to make modifications to this warranty, or additional warranties binding on APPI. Accordingly, additional statements such as dealer advertising or presentations, whether oral or written, do not constitute warranties by APPI and should not be relied upon. Warranty on equipment is considered void when outstanding balances become delinquent (over 30 days late - 60 days after ship date). Equipment Integration to other Equipment: APPI assumes no responsibility for the integration of its products to other products or within a system unless APPI performs the integration, testing and provides the results of the tests to the purchaser in writing. Furthermore, APPI assumes no responsibility for bag sizing whether suggested or recommended.

# US-5500 Kit Scale Operation

---

## Contents

- 1. Introduction..... 3
- 2. Access to Factory Settings ..... 3
- 3. Scale Factory Settings Screen: ..... 4
  - 3.1 Auto Zero Setup..... 4
  - 3.2 Calibration Procedure ..... 5
  - 3.3 Load Cell Comm Button: ..... 6
- 4. Kit Setup Screen ..... 6
- 5. Piece Count Setup: Kit Scale Operation ..... 8
- 6. US-5500 Bagger Settings..... 9
- 7. Step Operation Screen..... 11
- 8. Weight History..... 12
- 9. Scale Error Messages..... 13
- 10. US-5500 “Kit” Net Weigh Scale: Quick Setup Procedure ..... 13
- 11. Quick Setup Chart..... 14
- 12. Notes regarding Quick Setup Procedure:..... 14
- 13. US-5500 Level 1 Spare Parts Kit..... 15
- 14. Parts / Parts Drawings..... 15
- US-5500 System Layout ..... 16
- Stand Assembly ..... 17
- Partition & LED Light Subassembly ..... 18
- Scale Head Assembly ..... 19
- Touch Screen Assembly ..... 21
- US-5500 Module..... 22
- US-5500 Module..... 23
- 15. Electronic Schematics / Drawings ..... 25
- 16. Notes ..... 29

## 1. Introduction

The US-5500 "Kit" Net Weigh system is a versatile semiautomatic bagging system which provides for fast bagging of kits or one type of part per bag, in counts up to 10,000 pieces. If your company bags a wide variety of parts with multiple parts of various counts in bags, the US-5500 Kit Packaging System is an excellent solution for your company. Controlled through a 10" touch screen, the user friendly program setup screens allow you to sample parts quickly, change kit contents, save new kit settings and recall previously run kits. Because high capacity memory cards are available, you could store many kit settings for recall with minimal setup time. This manual addendum provides detailed and quick setup procedures for the US-5500 Kit Scale Bagging System. You should first read the T-1000 Operation Manual to become familiar with all safety and operation requirements before proceeding to setup the US-5500 system.

## 2. Access to Factory Settings

The US-5500 is considered an option to the T-1000 and is controlled via the T-1000 touch screen, scale controller, PLC and PLC expansion cards. Special screens are provided which control the operation of the US-5500. However, before the US-5500 screens are available for access, the Option must be enabled in the touch screen operator program. You must contact APPI Technical Support, if the scale screens are not activated.

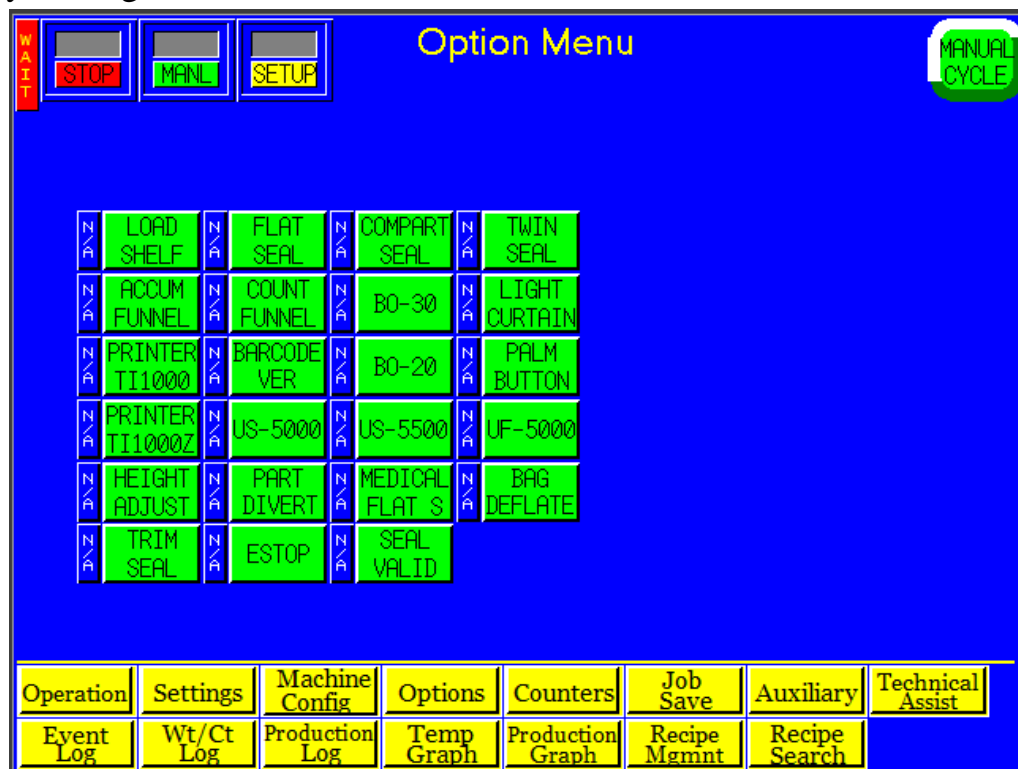

Figure 1

To determine if the screens have been activated, select Options from the Main Menu, See Figure 1. Then, press the US-5500 button. If the US-5500 Information screen is shown with an Activation button at the bottom of the screen, then the US-5500 programming has not yet been activated. Contact APPI Technical Support for information on how to activate the option.

If activated, the next step is to select the method of operation that best suits your products and applications. These settings are pass code protected in the Technical Assistance portion of the screens and are typically not changed, once set.

To gain access to the Technical Assistance: Scale Factory Settings, press the Tech Assist button from the Main Menu. You will be prompted for a Pass Code. See Figure 2.

The default Level 1 pass code is 1001. Once this is entered, the code can be changed to prevent access to unauthorized individuals. Select Pass Code Setup from the Technical Assistance Screen to change the Level 1 or Level 2 pass codes. See Figure 3.



Figure 2

### 3. Scale Factory Settings Screen:

The Factory Setting Screen allows the user to access the Bagger Factory Settings, Scale Factory Settings, and Scale Calibration in one location. Please refer to the following section for details.

#### 3.1 Auto Zero Setup

An information screen is provided for the Auto Zero function. See Figure 4 and Figure 5.

*Note: The Kit packaging operation method can be selected*

*for Single part operation also. However, due to the increased complexity of the screens and operations when packaging kits, additional training may be required for Kit packaging operations.*

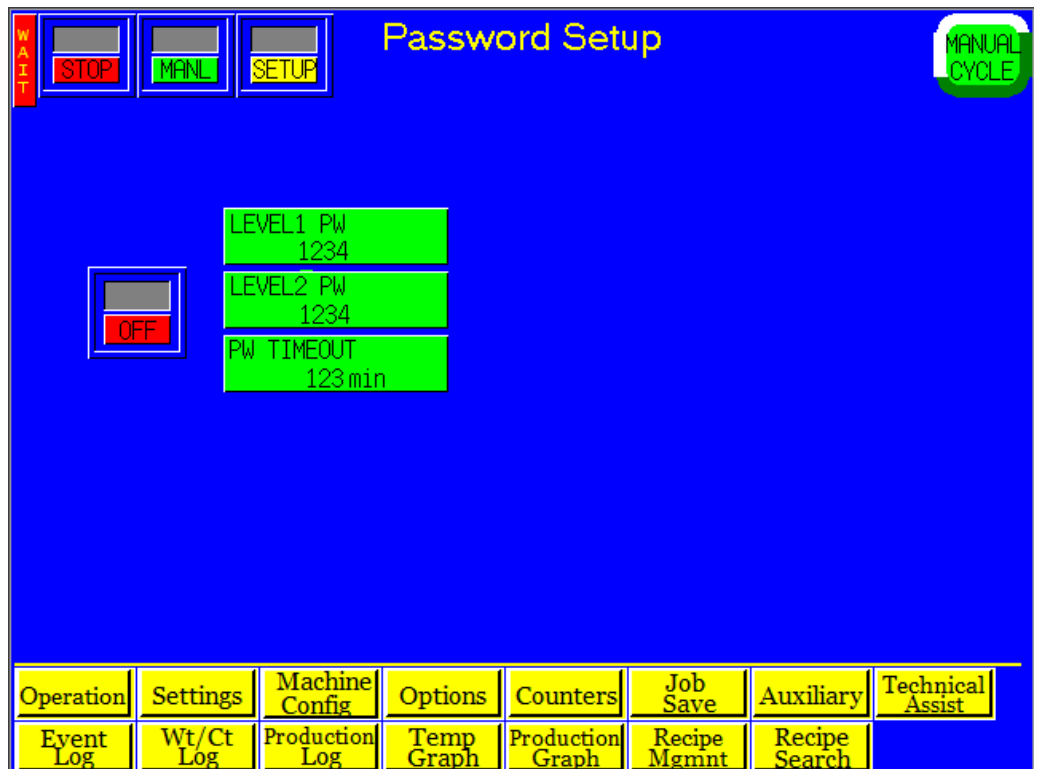

Figure 3

Time Out timer setting and Zero Range setting: The US-5500 is programmed with an auto zero function that allows the scale to automatically zero the scale if the two conditions are met: 1) Current weight is in the range setting and 2) Weight has been within the range setting for a preset time (Time Out). For instance, if the Zero Range is set to .003 lbs and the Time Out value is 3 seconds, the scale will

automatically zero if the scale is not in cycle operation and the current weight displayed is stable at .002 lbs. This function allows for more infrequent cleaning of the tray or environmental conditions which may affect the load cell. However, this function may not eliminate the need to periodically manually zero the scale.



Figure 4

### 3.2 Calibration Procedure

To calibrate the scale, a Calibration Screen is provided from the Factory Setting page. See Figure 5.

The scale should only be calibrated when a known weight weighs incorrectly on the scale. If running in the kit operation mode, the accuracy of the weight is not critical since a sampling method is used to determine the average piece weight.

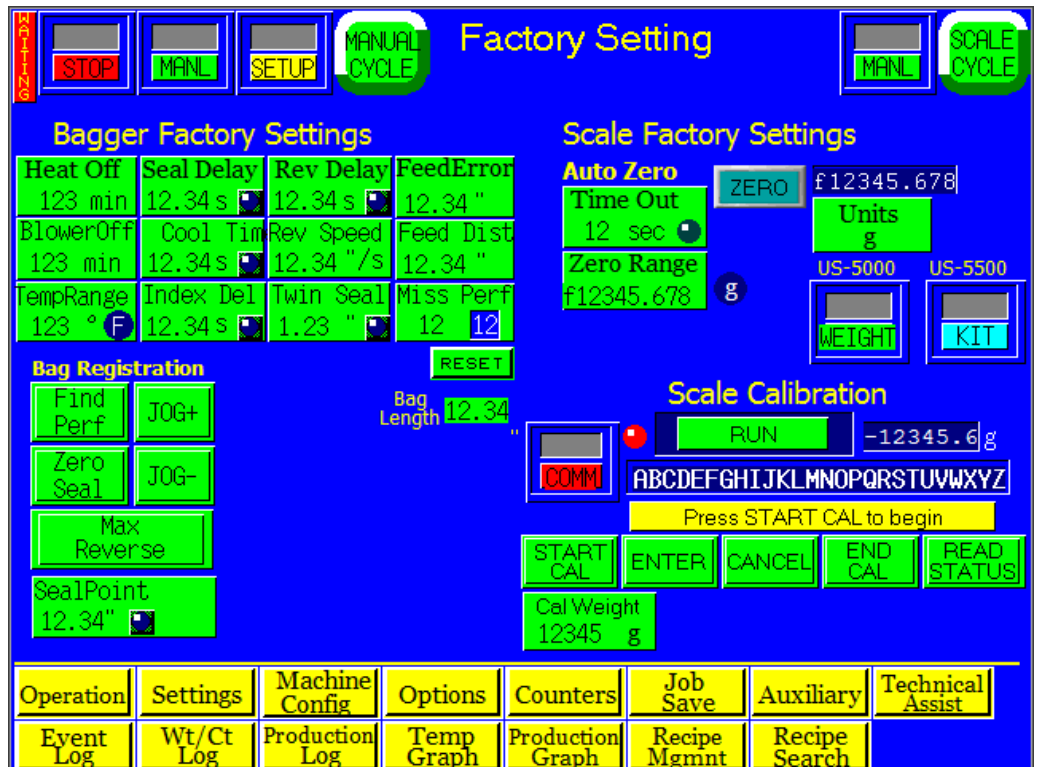

Figure 5

The following step by step procedure must be followed closely to properly calibrate the scale. A known metric calibration weight (in grams) must be used to properly calibrate the scale. The actual weight may

vary, but it should be at least 1000 grams. This weight may vary depending on the magnitude of load cell. Contact APPI Tech Support to discuss the calibration weight used during this procedure. This weight may also be purchased from APPI.

Procedure to Calibrate the US-5500:

Steps:

1. Press both START/STOP and RUN/SETUP toggle buttons, located at the top left side of the screen to place the unit in the Stop Mode.
2. Clean out the scale tray and remove any debris with a cleaning solution. Press the Zero button.
3. Press the Cal Weight button and enter the weight stamped on your weight (1000 grams, for instance), followed by the <ENT> button.
4. Press the <START CAL> button, read and follow the instructions displayed in the status bar.
5. When prompted, place the Cal Weight on the tray.
6. When complete, press the END CAL button.
7. Test the results by placing the Weight on the scale to ensure it measure the proper weight.
8. When satisfied the known weight reads accurately, toggle both START/STOP and RUN/SETUP buttons to the START position.

### 3.3 Load Cell Comm Button:

To assist with troubleshooting of the communication between the load cell and the PLC, the Load Cell Communication button is provided from the Factory Setting page. To check the communication between the Load Cell and the PLC, toggle the **COMM** button from red to green. The LED light on the right side of the **COMM** button will turn green if there is communication between the Load Cell and the PLC. If there is no communication between the Load Cell and the PLC the LED light will display red, even if the **COMM** button is green. For further information, please contact APPI technical assistance. See Figure 5.

## 4. Kit Setup Screen

Like the example below(See Figure 6), touch the light blue area to: Enter the Kit #, The Bag size, The Bin the parts will be picked from, The name of the part, The dump count (“0” if you want it to wait for the total weight),And the # of allowable Counted parts Over. Touching the Average Wt. blue box takes you to a sample screen where the correct count is placed in the tray, the correct number of parts is then entered on the calculator input. (Press ENTand SAVE). Go back to the Setup Screen and do the same for any additional Bin lines. When finished press the Calculate button on the right. SAVE it if it is a job you will run often. Press the RUN KIT button and it will take you to the Run Screen to run the kit. At the top of the screen put the top 3 buttons in Start, Run, and Auto. The 1st Bin Light should light up, put in the correct number of parts, it should dump into the bag, and the next bin light should light up. When all parts have been dumped into the bag, the bagger will cycle and drop away a good kit, then the 1st Bin light should light up again to start the filling of the next bag.

The Kit# is the Key Field which saves all settings. Before writing to the memory card, the Kit# database is scanned to ensure that no duplicate items are saved. Therefore, to prevent having duplicate entries, the Kit# must be a unique number.

To enter numeric data into Kit Setup Screen, press the field to display a number keypad. Once you have entered the data correctly, press the <ENT> button.

To setup a new kit, we recommend entering one line at a time and sampling each part before proceeding to the next part.

The first column in the detail settings section, below the Kit# and Bag PN header section, is the Seq# (or Bin#). If your kit contains six various parts, then you will enter a value from 1 to 6 in column 1. You should not have duplicates numbers. When running the program, the scale will cycle the various parts in the kit in this order. If your kit contains only two different parts, then you should have a number 1 and a number 2 in the first

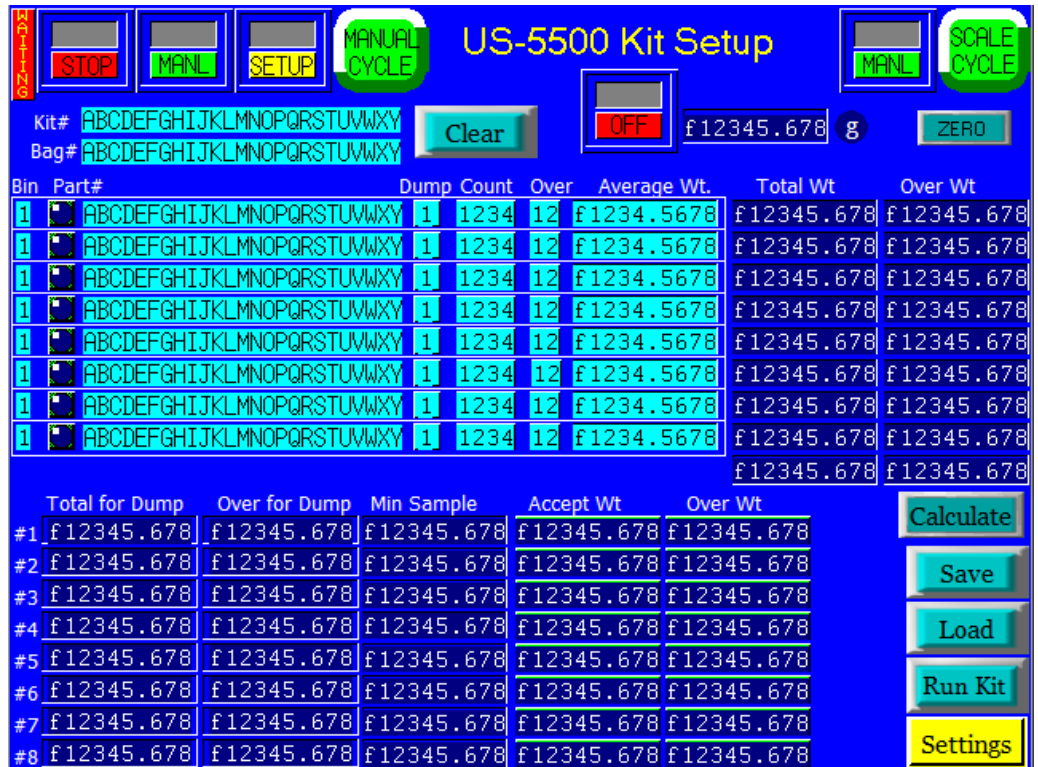

Figure 6

two rows of the detail section. Additionally, all the remaining Seq#s must be set to 0. Entering a 0 in the Seq# bypasses that line.

The second column of the detail settings section, labeled Part#, allows you to enter a numeric value, up to 6 digits. This number does not need to be unique and is only used for the operator to reference which part should be loaded.

The third column, labeled Count, allows you to enter a quantity for each part number in the kit, up to a four digit numeric value.

The fourth column, labeled Over, allows you to enter a value which you authorize an operator to “give away”. By entering an over value of 1, for instance, with a desired count of 10, allows the scale to cycle with a range of 10 to 11 parts. If no overages are authorized, then enter 0 in the Over column.

The fifth column, labeled Dump, allows you to toggle between Dump-NO to Dump-Yes. After the correct quantity of parts (within the acceptable range) has been weighed, the scale tray with either tilt forward, dumping the parts, or simply zero (not dump). Current Bin and Total weight is discussed in the following sections.

*Note: Although the data format indicates that the Dump value is numeric in the format above, the touch screen allows for toggling from Yes to No.*



The sixth and final column is a menu button labeled Sample. Pressing this button will display a Piece Count Setup screen which will allow the scale to calculate the Average (One) Piece Wt. Once complete with the Piece count Setup, discussed in the next section, you will return to the Kit Setup Screen where all settings can now be saved by pressing the Job Save button.

Additionally, once all settings are completed and the Kit is saved, you can press the Run button, located on the bottom right of the screen, to start the kit program sequence.

## 5. Piece Count Setup: Kit Scale Operation

The average piece weight must be established for the scale to accurately “count” the parts. The scale should be in Stop, Manual or Setup mode prior to performing this step. Press the Sample button from the Kit Setup Screen to start the Piece Count setup routine. See Figure 7. The scale tray should be empty, clean and the scale at Zero before proceeding. Press the

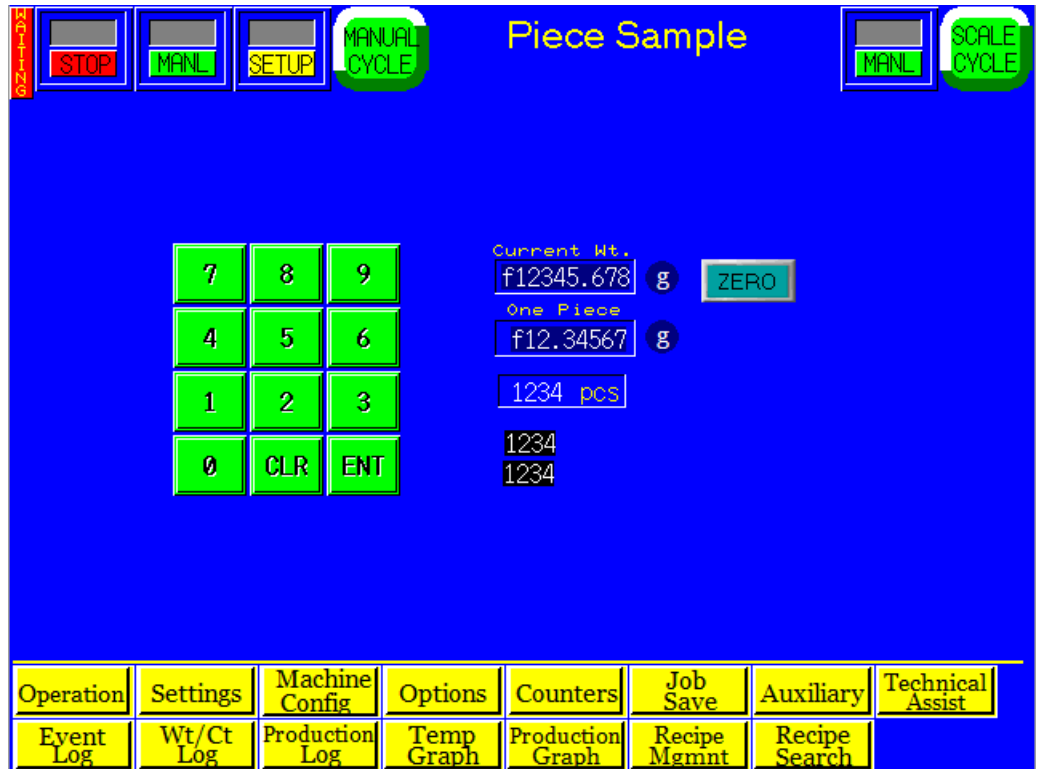

Figure 7

Scale Cycle button to clear the scale. Clean the scale tray, then press the Zero button. Manually count a quantity sufficient to accurately determine the average piece weight. For smaller or lighter products, we recommend a higher quantity for the sample count. Enter the value of the batch count using the number keypad and press Enter. Notice the One Piece weight value on the screen. Then press the Enter key again. If the One Piece value did not change, the One Piece weight or "Average Piece Weight" has been established. As a final test, remove and add one piece at a time ensuring the Quantity changes accordingly.

*Note: A higher batch count will establish a more accurate Average (One) Piece weight.*

Due to "Lot" weight variance, this count setup procedure should be conducted on a regular basis. We recommend performing the sampling procedure during the setup of every new part. If the piece Quantity does not accurately display the number of pieces in the tray when one piece is removed, it may be due to varying piece weight. For very light pieces, the Quantity display may be constantly changing. If this occurs, the range may need to be increased to allow for the scale accuracy increments. Some parts may weigh less than the scale minimal increment. For instance, you may need to remove 5 parts for the scale to decrement by a quantity of 5.

*Note: To avoid injury, the system should be in the Stop Mode before attempting to clean the scale tray.*

From this screen, you can also test that the Auto Zero functionality of the scale does not Ensure that the final batch weight is not within or close to the Auto Zero Range. If the scale zeroes with the parts in the

scale, the Auto Zero range setting must be adjusted. Additionally, the Auto Zero timer can be changed to prevent the scale from automatically zeroing during the cycle operation.

When satisfied with your testing, press the Save button.

## 6. US-5500 Bagger Settings

The US-5500, when set to the Kit mode of operation, has all timers for the scale located on one screen. Dump time, settle time, fill time, air pulse, seal point, seal time, reverse, blow off, index speed and seal temperature can be adjusted from this screen. See Figure 8.

STOP/START toggle button: The system must be in START position to run the bagger and/or scale.

MANL/AUTO toggle button: If running in the footswitch mode or if you are setting up the scale, the MANL position can be selected. To have the scale automatically cycle when the weight/count is in the acceptable weight range, toggle the button to AUTO.

**Caution: When the scale is in AUTO, the scale tray will tilt forward automatically. To avoid injury, do not reach into the tray area when the scale is in this mode unless the scale has gone into an OVER condition. An OVER condition disables the Auto cycle operation.**

SETUP/RUN toggle button: If setting up the scale or bagger, the setup position is recommended. This setup mode stop cycle counters from running and allows for bagger setup without operating the scale.

Status display: When the scale is in the zero range, the Status display will display “Status” which indicates that the scale is idle. If over the zero range, the UNDER status will be displayed. If in the acceptable weight range, then ACCEPT status will be displayed. If the weight/count has exceeded the acceptable weight, then OVER status will be displayed. When the scale is in the OVER status, the scale must be cycled using the MANL or SCALE CYCLE button. Additionally, you may press the footswitch to cycle the machine.

SCALE CYCLE button: Press the Scale Cycle button to cycle the scale. This will also cause the scale tray to tilt forward dispensing the product.

Current Weight / Current Pieces displays the weight or count (pieces) of the product in the tray. If no product is in the tray and the weight is not zero, press the ZERO button to zero the scale.

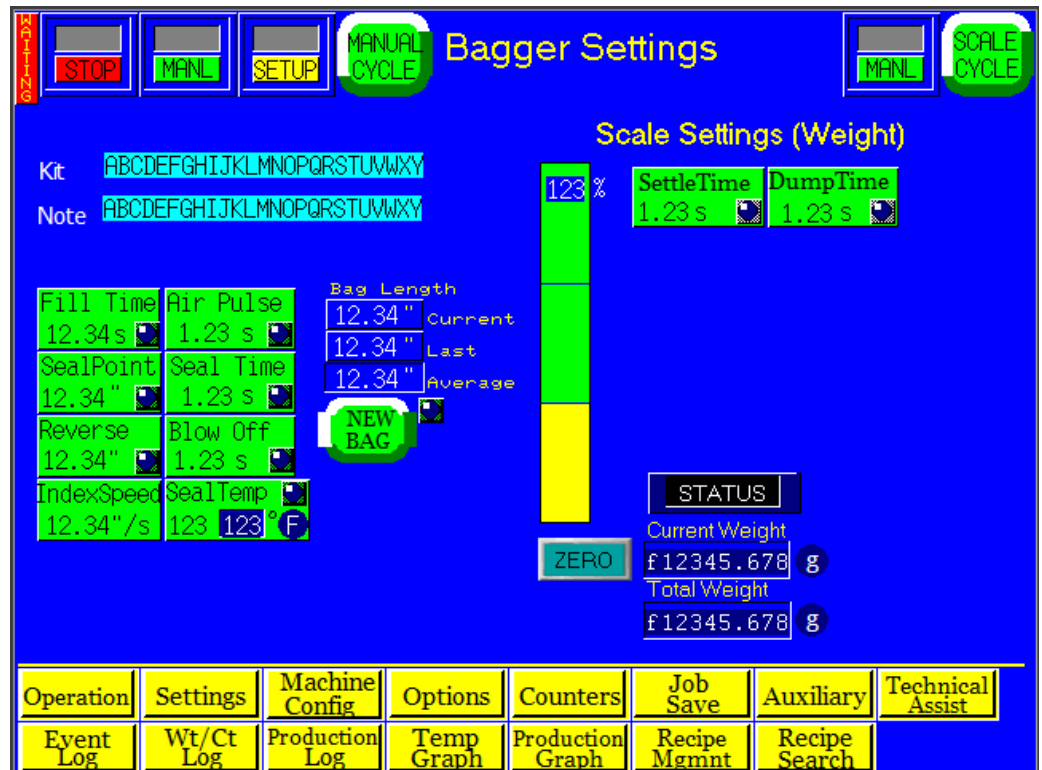

Figure 8

**Dump Time:** This timer is how long the tray actually tilts forward, dispensing the parts into the bag. This time should be sufficient to consistently allow all parts to fully exit the scale tray. A typical setting for the Dump Time is 0.5 seconds. A time setting too low will cause all parts not to be fully exit the tray causing an undercount or underweight in the bag. A time value high will cause decreased production.

**Settle Time:** This timer is how long the scale must be in the Accept Weight or Count mode before the scale can start the cycle operation. A typical Settle Time setting is 0.3 to 1 second, depending on the product. A time setting value too low will cause inaccurate weights/counts. Additionally, a time value too high will cause decreased production.

**Fill Time:** This is the time between when the scale completes it dump cycle and when the bag starts to seal. This timer value should be sufficient for the product to fully and consistently enter the bag before the bag is sealed. A typical setting is between 0.2 and 0.6 seconds. A time setting too low will cause the seal bar to seal on the product. A setting too high will cause decreased production. This timer value can also be changed on the Bag Setup Screen.

**Air Pulse:** The amount of time that a burst of air will *initially* blow the bag open. Wider bags and heavier gauge bags require a longer burst of air. Additionally, to increase the *volume* of air from the air pulse tubes, turn the Air Pulse valve counter-clockwise. Flow control valves are located on the right lower side of the seal frame assembly to increase or decrease air through the air pulse tube or blower.

Typical setting for Air Pulse is 0.2 seconds for smaller bags and 0.4 seconds for larger bags. If the index speed is lower (6-15"/Sec), the Air Pulse may need to be longer.

**Seal Point:** Seal point is measured from the top of the bag and can be set to the desired or required location.

The proper positioning of the seal on the bag varies due to bag size and product characteristics. Wider bags or bulky products require greater sealing area. Typical settings for Seal Point: .8 inches for narrower bags, 1.2" mid-size widths and 1.5" for wide bags.

<New Bag> button is used to start an internal program which calculates an average bag length. The perf is used for registration. If a perforation is not detected, the bag will stop in the correct seal position based on the average bag length measurement. A Feed Error message will be displayed if the perf is not detected within a range of acceptance of bag length.

**Seal Time:** Seal Time is the time the heater bar comes in contact with the rubber strip, which is mounted on the pressure bar. Seal time is one of three critical components to obtain a good quality seal. Other critical factors include seal temperature and seal pressure. After adjusting Seal Time, test for good seals and adjust if necessary.

Typical settings for Seal Time with temperature set to 400 degrees F: 0.3 seconds for thinner bags (1.5 mil), 0.4 seconds for medium thicknesses (2 to 3 mil) and .7 for heavier thicknesses (4 mil). However, the set temperature will affect the required seal time. If adjusting pressure or temperature, test various seal times until satisfied with the seal quality.

Reverse: The distance the bag reverses can be set to cause the perforation to break between the bags. For wider bags, the reverse distance may need to be increased. A typical setting is 1".

Blow Off: A blow off tube is provided to decrease the possibility of bags sticking to the PTFE. Increase the blow off time if bags are not falling from the machine. Typically, the blow off time is set to .15 to .25 seconds.

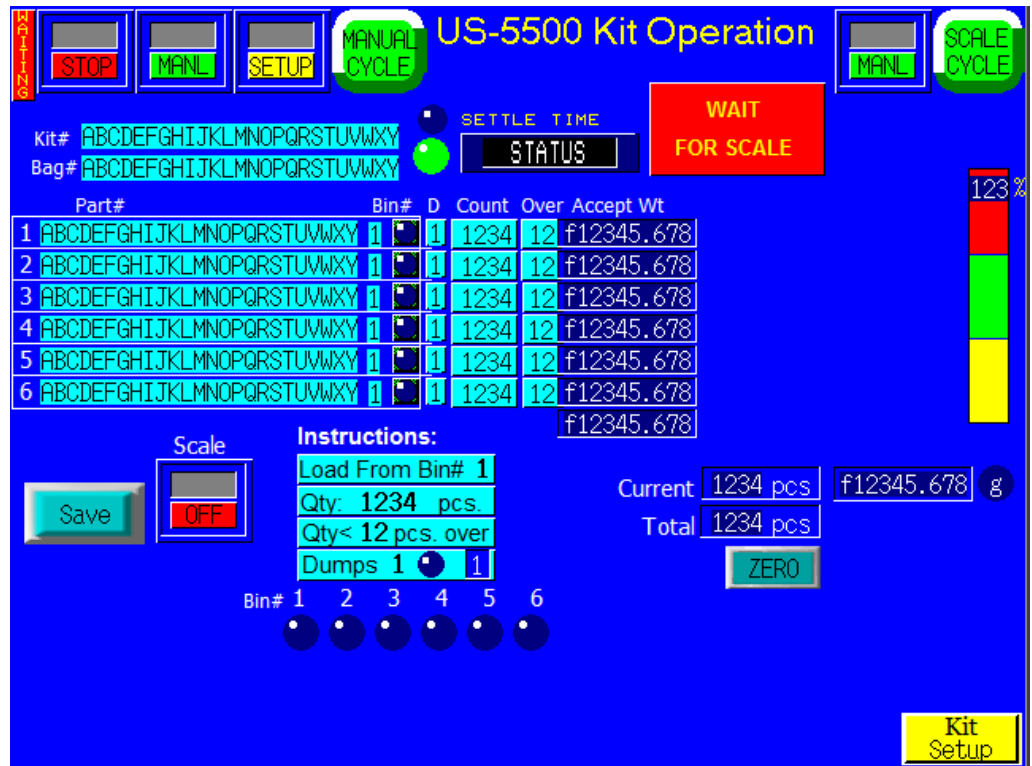

Figure 9

Index Speed: Bag feeding (index) speed can be set to improve production. If bags are prematurely breaking at the perforation, reduce the index speed. For shorter bags, the speed can be significantly decreased (to 10"/Sec, for instance). The typical setting is between 15 and 25" per second.

Seal Temp: Electrical current is pulsed to the heater element to maintain a constant temperature. Waiting LED is displayed if the temperature is not within the set range. The typical temperature is setting is between 360 and 440 degrees depending on film thickness.

Test the timers by pressing the Scale Cycle button.

## 7. Step Operation Screen

The US-5500 Step Operation screen automatically runs through a programmed sequence of operation when the Run button is pressed on the Kit Setup Screen. Depending on the number of various types of parts in the kit, the Operation Screen may be refreshed up to six times. The Kit Operation Screen provides text instructions to the operator, flashing messages, status, weight/count data and graphs to inform the operator as to the proper sequence of loading and status of counts. See Figure 10.

Two message blocks are provided which advise the operator to "Start Loading" or wait. Also, specific instructions are given indicating the sequence or bin to load from, the part number and quantity. Also, dump information is provided so that the operator will know in advance if the scale tray will dump when this part has been loaded properly.



## 9. Scale Error Messages

Several message screens may display during the cycle operation of the scale. These faults must be cleared before continuing operation. See Figure 12 and Figure 13.

The screens describe the problem and a possible solution. Otherwise, contact APPI Technical Support for assistance.

Refer to the T-1000-S14 manual for other fault messages.

## 10. US-5500 “Kit” Net Weigh Scale: Quick Setup Procedure

The following procedure is provided as a step by step method of operation. Before proceeding with this procedure, ensure that the bagger is setup with proper size bags in the loading position, funnels and guards are in place, and air and power is attached to the machine. Also, all timer settings should be already set and tested. See Chapter 2, 3 and previously in this addendum for more information regarding the US-5500 and T-1000 bagger setup.

### Procedure Steps: New Kit Setup

1. From the Main Menu, press the Options menu button, then the US-5500 menu button.
2. Reset the values by entering 0 in Kit Part Number field and press Job Load. (See Note 1)
3. Enter the Kit # by pressing the Kit # field, entering the values (up to 10 digits) on the keypad and press the <ENT> button. Enter the Bag PN in the same method.
4. Create your kit by entering the data, one row at a time for the Bin#, Part#, Count, Over, Dump (Yes/No). Before going to the next line, press the <Sample> button.
5. Press the <Scale Cycle> button to dump and clear the scale. Press the <Zero> button.
6. Count out the required quantity of parts (or a higher quantity) and place the batch in the scale tray. Enter the Qty of parts that are in the scale and press the <ENT> button to determine the Average Piece Weight.
7. Verify that the setting is correct by removing one part at a time and adding one part at a time to decrement or increment the Quantity. Press the <Save> button to continue. (See Note 2)
8. Repeat Steps 4 through 7 to setup the remainder of the parts in the kit.
9. Review all settings on the Kit Setup Screen for accuracy. (See Note 3)
10. Clear the Scale by pressing the <Scale Cycle> button.
11. Clear the bagger by pressing the <Manual Cycle> button.



Figure 12



Figure 13

12. Press the <Job Save> button. (See Note 4)

13. Press <Run> to start the kit bagging operation. Then press the AUTO toggle button to go from MANL to Auto. (See Note 5)

14. If an error occurs or the operation stops, press the <Kit Setup> button and check all settings and press the <Run> button when ready to start again. (Note 6)

A setup chart has been included to assist you, if you wish to write down all the settings, prior to starting the setup procedure above.

## 11. Quick Setup Chart

Kit #			Bag PN		
Seq #	Part #	Count	Over	Dump (Circle One)	Sample Qty
				Yes / No	
				Yes / No	
				Yes / No	
				Yes / No	
				Yes / No	
				Yes / No	

## 12. Notes regarding Quick Setup Procedure:

Note 1: Kit # 0 has been save with all field blank for easy setup of a new kit. Loading Kit #0 should reset all values on the Kit Setup Screen to 0. However, you can enter any setting you want as a default setting and save the setting as Kit #0. If you load Kit #0 and there are values, press each field and enter 0, then press Job Save to save the settings for easy setup of a cleared screen job.

Note 2: To increase the accuracy of the scale, ensure you count out the test sample batch carefully. The higher the quantity, the more accurate the average piece weight value will be.

Note 3: When reviewing the Kit Setup Screen settings for accuracy, ensure that the following is considered:

a) Confirm that for each Part# line, a unique number precedes each Part#. This number represents the sequence of loading (SEQ#) or bin location.

b) If a line is not used, confirm that the Seq# is to 0 (bypass).

c) The highest Seq# will be last Part# loaded. Confirm that the Dump setting is Yes for this Part#.

Note 4: If after pressing the Job Save button a message is displayed prompting you to overwrite or cancel, this means that the Kit# already exists in the database. See your database manager or setup supervisor before proceeding.

Note 5: You can operate the scale from MANL by pressing the footswitch or MANL cycle button from the touch screen. The scale will not cycle unless in the Setup mode or the count is in the range (Accept weight). In the Auto mode, the scale will automatically cycle when Accept is achieved. If an Over condition occurs, remove the parts from the tray and press the footswitch or MANL cycle button to continue.

Note 6: Each time you press the <Run> button, the first Seq# line will be cycled. Therefore, if an error occurs, you should clear the scale and cycle the bagger prior to pressing the Run button.

### 13. US-5500 Level 1 Spare Parts Kit

The following list of recommended spare parts kit is provided. To order this kit or individual parts, please contact Customer Service.

Qty:	Part Number:	Description:
1	TP-7500052	Load Cell, 10kg
1	TP-402255	Valve
1	TP-403008	Cylinder
2	TP-107131-1	Flange Bearing

### 14. Parts / Parts Drawings

The following pages describe and illustrate parts for the US-5500 Kit Scale.

Contact APPI Customer Service to order parts for your system.

Please reference APPI part numbers.



# US-5500 System Layout

T-US5500

ITEM NO.	PartNo	DESCRIPTION	QTY.
1	TA-T4-2000	STAND ASSEMBLY	1
2	TA-T4-5000	SCALE HEAD ASSEMBLY	1
3	TA-T4-6000	TOUCH SCREEN ASSEMBLY	1
4	TP-T4MA5413	MOUNTING BRACKET	1
5	TP-T7M5025	MODULE SUPPORT SHELF	1
6	TA-T4-1000-BOX	US-5500 MODULE	1
7	ASSEMBLY OF PARTS	PARTITION ASSEMBLY	7
8	ASSEMBLY OF PARTS	LED LIGHT ASSEMBLY	8

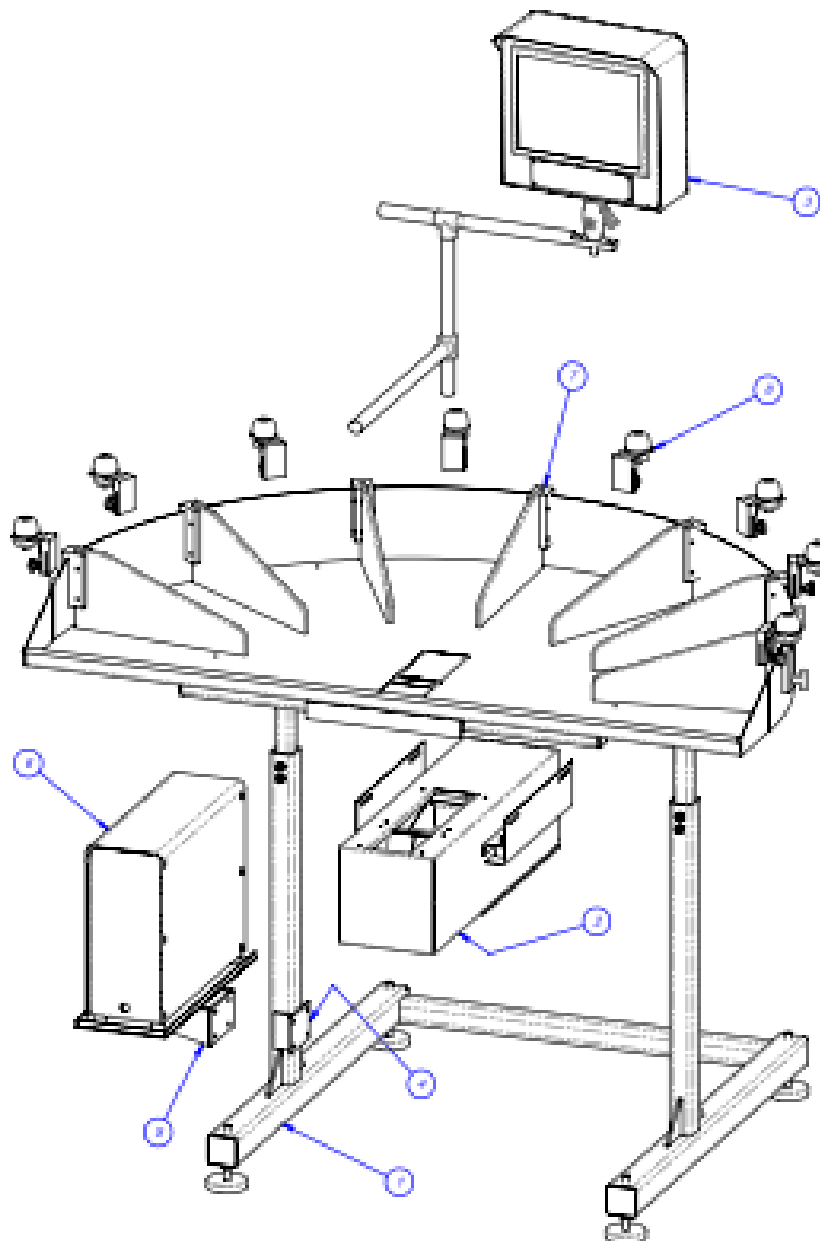

# Stand Assembly

TA-T4-2000

ITEM NO.	PartNo	DESCRIPTION	QTY.
1	TP-T4MA5401	LOWER STAND WELDMENT	1
2	TP-T4MA5402	UPPER STAND	1
3	TP- 110764	ADJUSTABLE PAD	4
4	TP- T4MA5123	CLAMP BLOCK	1
5	TP-T4MA5403	SORT TABLE TOP	1
6	TP-T4MA5409 -1	PARTITION TRAY - OPEN SCALE & SORT	1
7	TP-T4MA5409-2	PARTITION TRAY - OPEN SORT	1
8	TP-T4MA5409-3	PARTITION TRAY - OPEN SCALE	1

*NOTE: Items 6, 7, and 8 are interchangeable based on model. Item 6 is used for the Sort-and-Weigh Model, Item 7 is used for the Sort Table Model and Item 8 is used for the Weigh Model.*

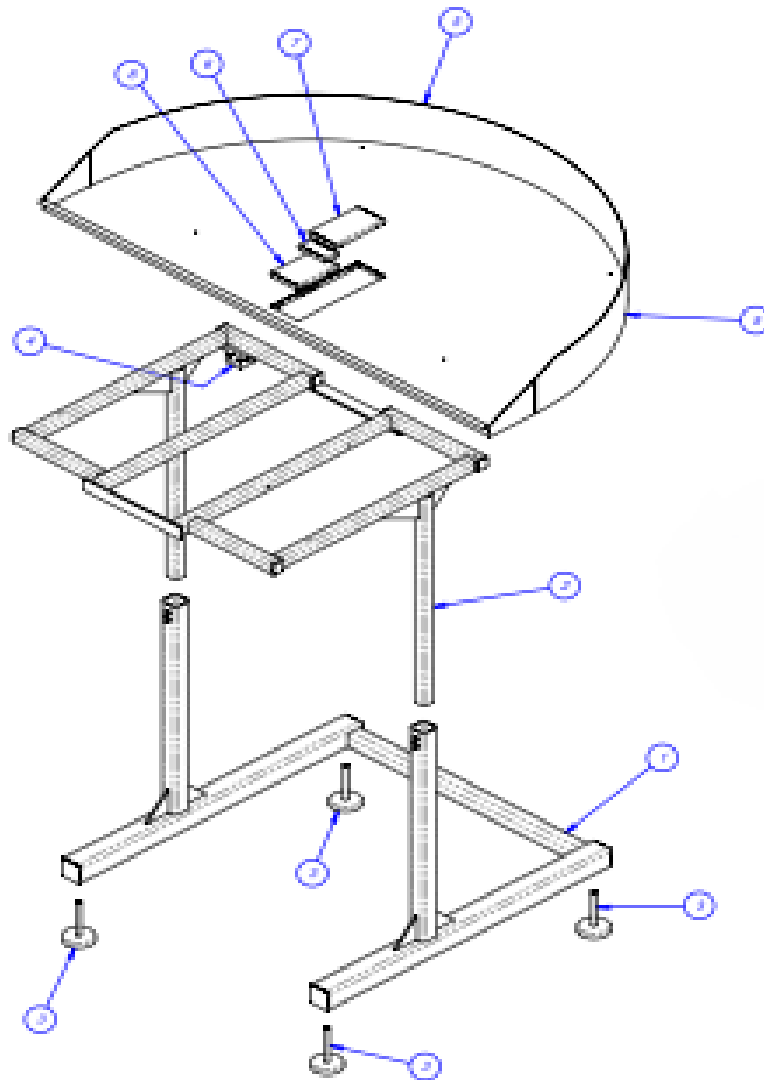

## Partition & LED Light Subassembly

### Stand Sub Assembly

Partition Assembly			
ITEM NO.	PartNo	DESCRIPTION	QTY.
1	TP-T1MPT3006	PARTITION CLAMP	1
2	D9-107633-1502	PARTITION	1
3	TP-109212-1	T KNOB	1

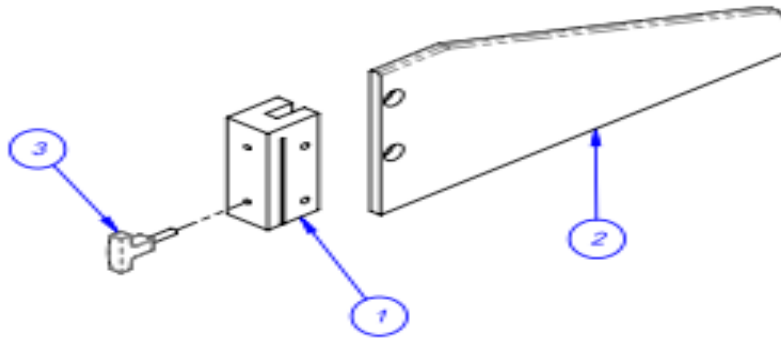

LED Light Assembly			
ITEM NO.	PartNo	DESCRIPTION	QTY.
1	TP-T4MA5130	LIGHT MOUNTING BLOCK	1
2	TP-216157	EZ-LIGHT MOUNT	1
3	TP-216156	EZ-LIGHT	1
4	TP-109212	1/4-20 x 1.00" THREADED KNOB	1

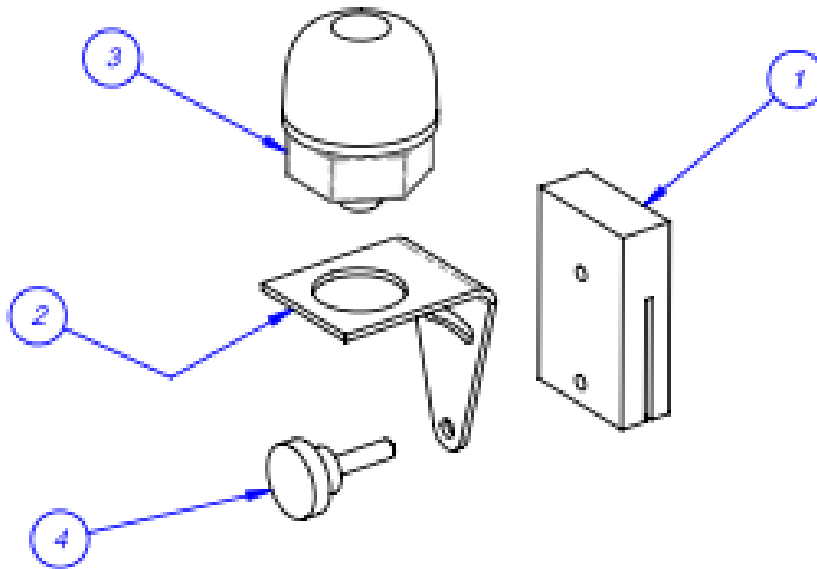

## Scale Head Assembly

TA-T4-5000

ITEM NO.	PartNo	DESCRIPTION	QTY.
1	TP-T4MA5114	BASE PLATE	1
2	TP-T4MA5106-1	LOAD CELL MOUNT LOWER	1
3	TP-T4MA5106	LOAD CELL MOUNT UPPER	1
4	TP- 107131-1	BRASS FLANGE BEARING	2
5	TP-T4MA5105	LOAD CELL PIVOT SHAFT	1
6	TP-T4MA5102-1	SCALE HEAD FRAME	2
7	TP- 7500052	LOAD CELL 10 kg	1
8	TP-T4MA5129	BACK PANEL HINGE	2
9	TP-T4MA5115	BACK PANEL	1
10	TP-T4MA5118	SCALE HEAD ENCLOSURE	1
11	TP-T4MA5112	SCALE HEAD TRAY (STANDARD)	1
12	TP-110761-1	VIBRATION MOUNT	4
13	TP-T4MA5404	UPPER SCALE MOUNT	2
14	TP-T4MA5405	LOWER BRACKET	2
15	TP-403008	AIR CYLINDER	1
16	TP-403282	CYLINDER BRACKET KIT	1
17	TP-504102	SEALMASTER, CTFD SERIES RODEND	1
18	TP-402187	FLOW CONTROL, 1/4 NPT	2
19	TP-T4MA5122	MATERIAL STOP	2
20	TP-402184	FLOW CONTROL	2
21	TP-402173	BRACKET	1
22	TP-402255	VALVE	1
23	TP-111107	CLAMP ON COLLAR	2
24	TP-406259	MiniReg, Bracket, Guage	1
25	TP-401265	1/4" FITTING	1
26	TP-401256	BULK-HEAD FITTING	1
27	TP-404263	MUFFLER	2
28	TP-401277	ELBOW, 1/4" TUBE x #10-32	2
29	TP-T4MA5411	PRODUCT STOP	1
30	TP-T4MA5410	SCALE HEAD ENCLOSURE CHUTE	1

# Scale Head Assembly

TA-T4-5000

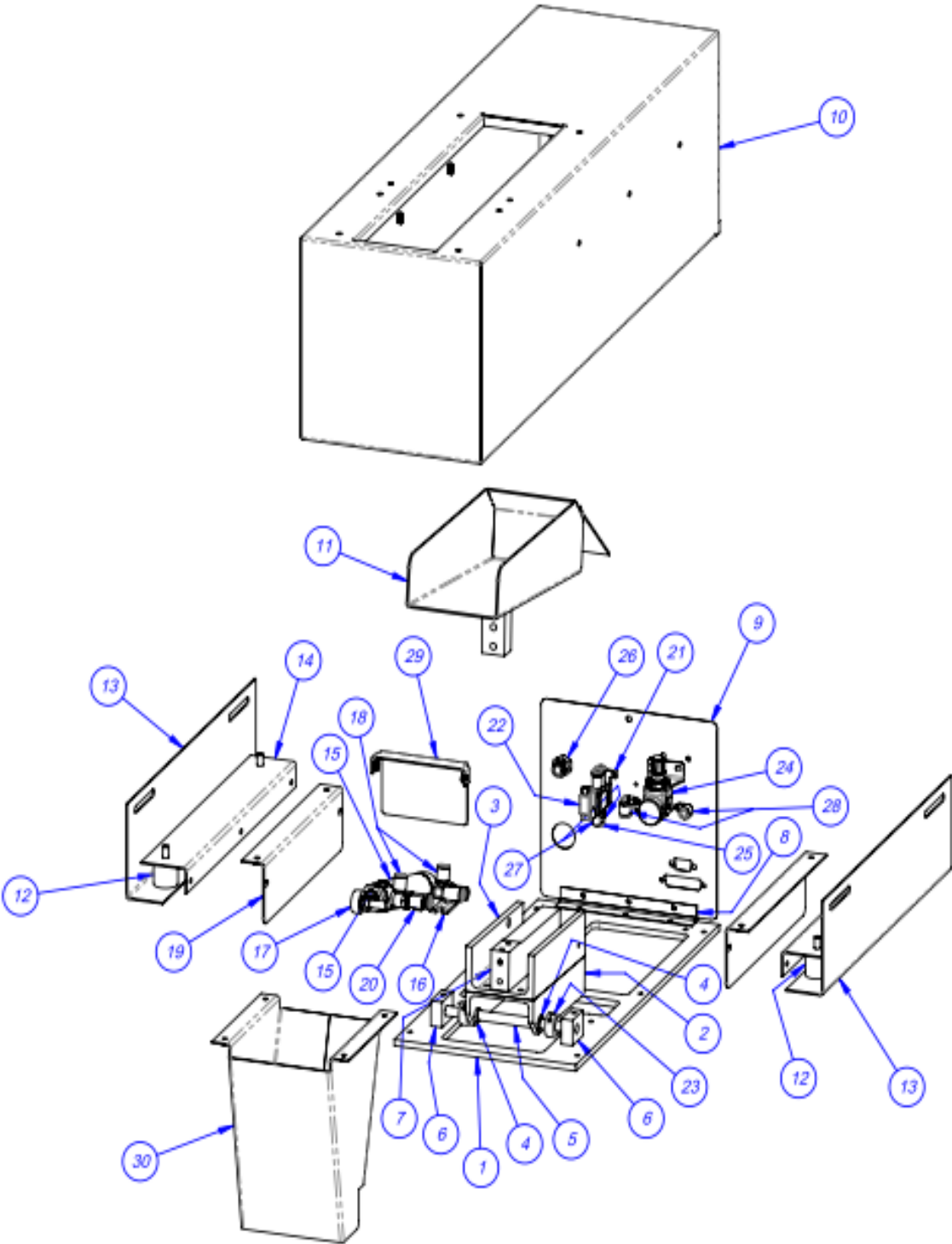

# Touch Screen Assembly

TA-T4-6000-1

ITEM NO.	PartNo	DESCRIPTION	QTY.
1	TP-T1MD00109	MOUNTING BAR	1
2	TP-111215	JOINING TEE	2
3	TP-T1MD00094	BASE TELESCOPE	1
4	TP-T1MD00109-1	MOUNTING BAR	1
5	TP-111131	BALL GRIP POSITIONING ARM	1
6	TP-111125-2	SOCKET ARM	1
7	TP-IOPBOLT	MODIFIED BOLT	1
8	TP-T9MA3001	10" IOP HOUSING	1
9	TP-T9MA3002	BACK PLATE	1
10	TP-T1MD00039-3	IOP FRONT PLATE	1
11	TP-220361	10" TOUCH SCREEN	1

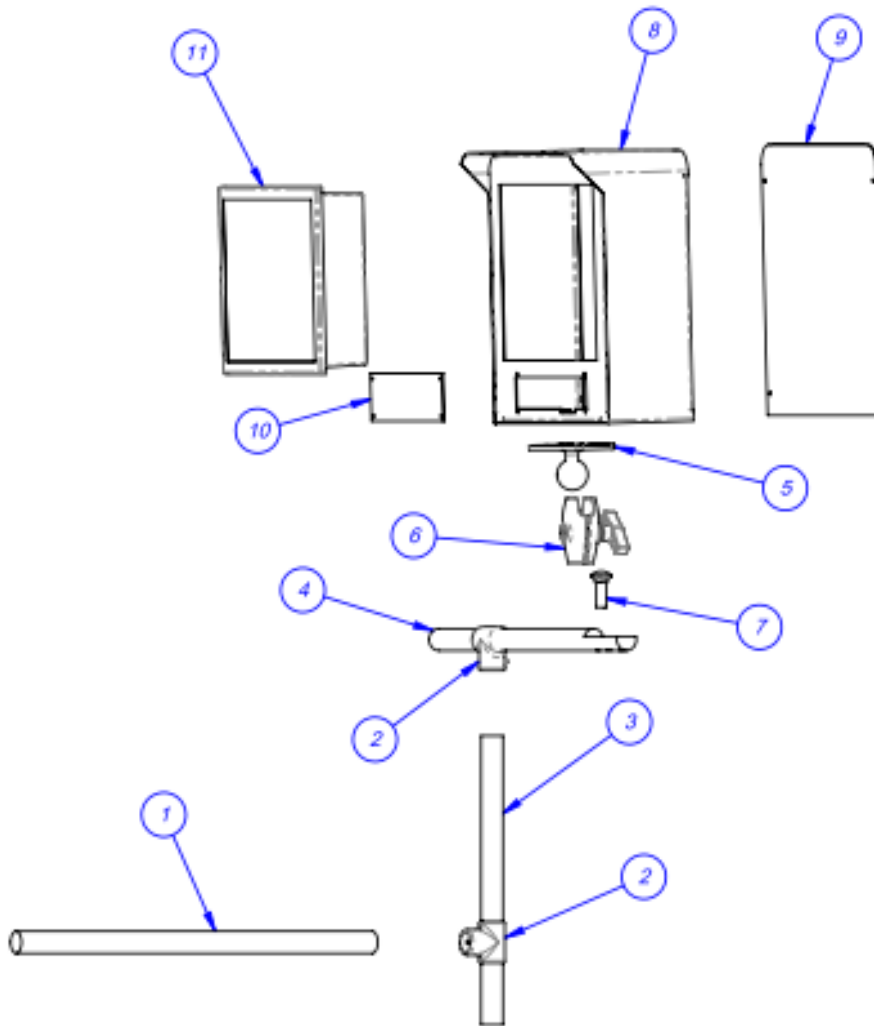

US-5500 Module

TA-T4-1000-BOX

ITEM NO.	PartNo	DESCRIPTION	QTY.
1	TP-MM1-0002	ELECTRONICS PANEL	1
2	TP-MM1-0001	ELECTRONICS BACK PANEL	1
3	TP-MM1-0003	BACK COVER	1
4	TP-MM1-0004	FRONT COVER	1
5	TP-MM1-0005	STAND-OFF	2
6	TP-T10MM1006	OVERLAY	1
7	TP-205108	EMI FILTER, CORCOM	1
8	TP-	DIN RAIL	1
9	TP- 208142	LARGE TERMINAL BLOCK	34
10	TP-214272	3/4" 6-32 STANDOFF	4
11	TP-218021	DIN RAIL	1
12	TP- 750102	SCALE CONTROLLER MO 460	1
13	TP-214275	STAND-OFF	4
14	TP- 213361	24VDC, 3AMP POWER SUPPLY	1
15	TP-214273	STAND-OFF, NYLON, 1/2", #4-40	4
16	TP-215005	SWITCH	1
17	TP-215004	SWITCH KNOB	1
18	TP-218020	DIN RAIL	1
19	TP- 220511	PLC, FPG-C32T2H GREY	1
20	TP-220504	PLC, FPO-E32T-A Expansion I/O	1
21	TP-215116	RELAY SOCKET	1
22	TP-110766	1 INCH DIA. RUBBER FOOT - 1/4-20 x .375 STUD	4
23	TP-212410	AC OUTLET	1
24	TP-212248	CONNECTOR, MULTIPOLE RECTANGULAR	1
25	TP-207216 , TP207344	FUSE HOLDER & FUSE	1
26	TP-212160 5	POS MINI DIM	1
27	TP-212247	CONNECTOR, MULTIPOLE RECTANGULAR	2
28	TP-212167	6 PIN FEMALE	1
29	TP-TP-212229	7 PIN AMPHENOL MALE	1
30	TP-112240	POWER CORD STRAIN RELIEF	1
31	TP-102155	Washer, 1/4" LOCK	4
32	TP-101111	Nut, 1/4-20 HEX	4

# US-5500 Module

TA-T4-1000-BOX

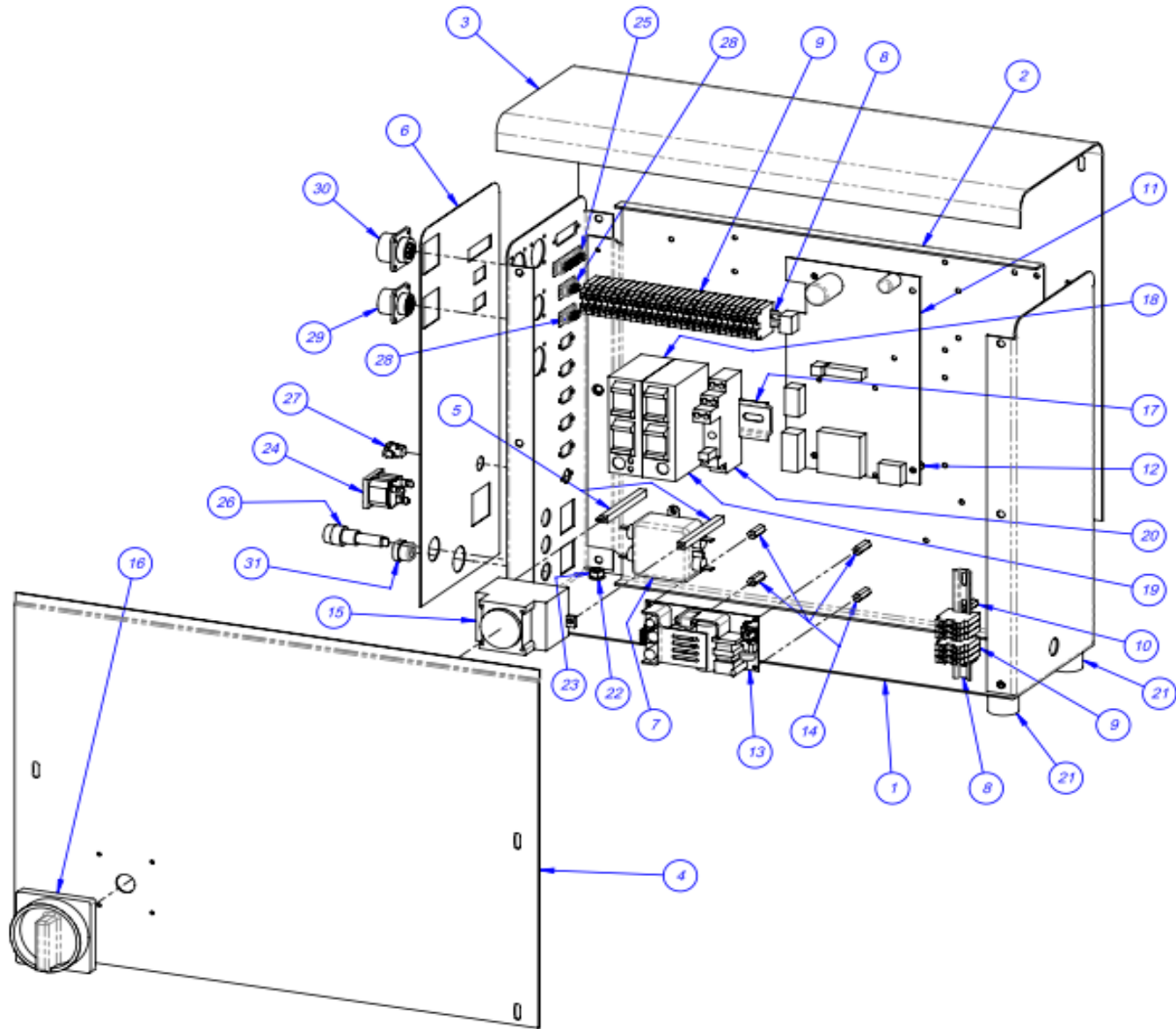



# US-5500 Module Subassembly

TA-T4-1000-BOX

ITEM NO.	PartNo	DESCRIPTION	QTY.
1	TP-T4MA5115	BACK PANEL	1
2	TP-402255	VALVE	1
3	TP-214103	STRAIN RELIEF, 1" HOLE	1
4	TP-218021	DIN RAIL	1
5	TP-208141	TERMINAL BLOCK	21
6	TP-212249	CONNECTOR, MULTIPOLE RECTANGULAR	1
7	TP-208149	FIXED BRIDGE	2
8	TP-208410	DIRECT MOUNT TERMINAL BLOCK	2
9	TP-401288 & 89	CONNECTOR & PINS FOR VALVE	1

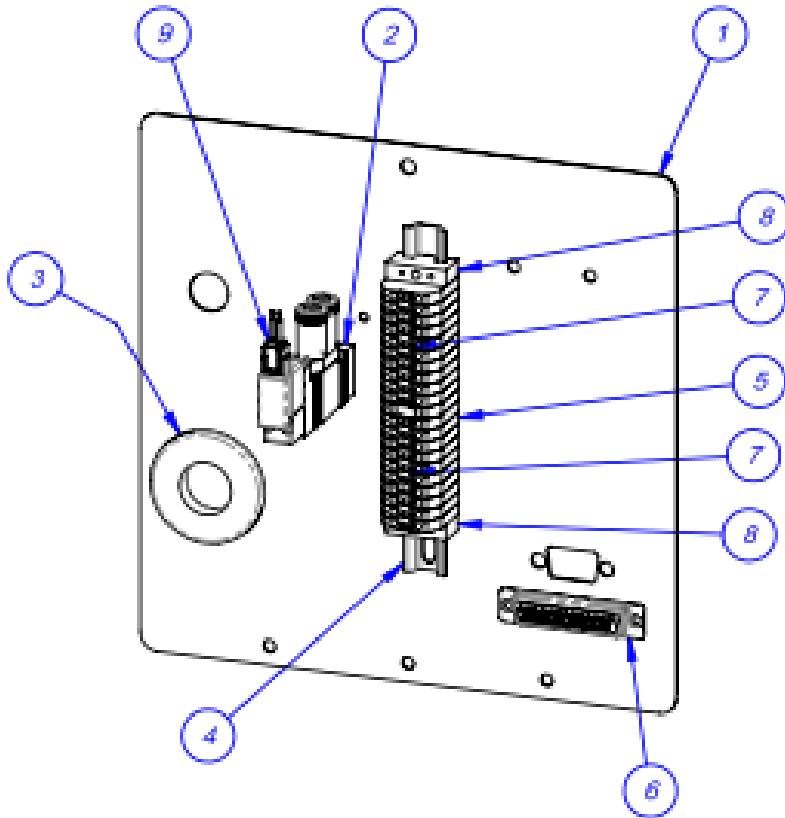

## 15. Electronic Schematics / Drawings

The following pages describe and illustrate the electronic makeup of the US-5500 Kit Scale.

Contact APPI Customer Service for questions pertaining to your system.

# Electrical Drawing

## FPG I/O

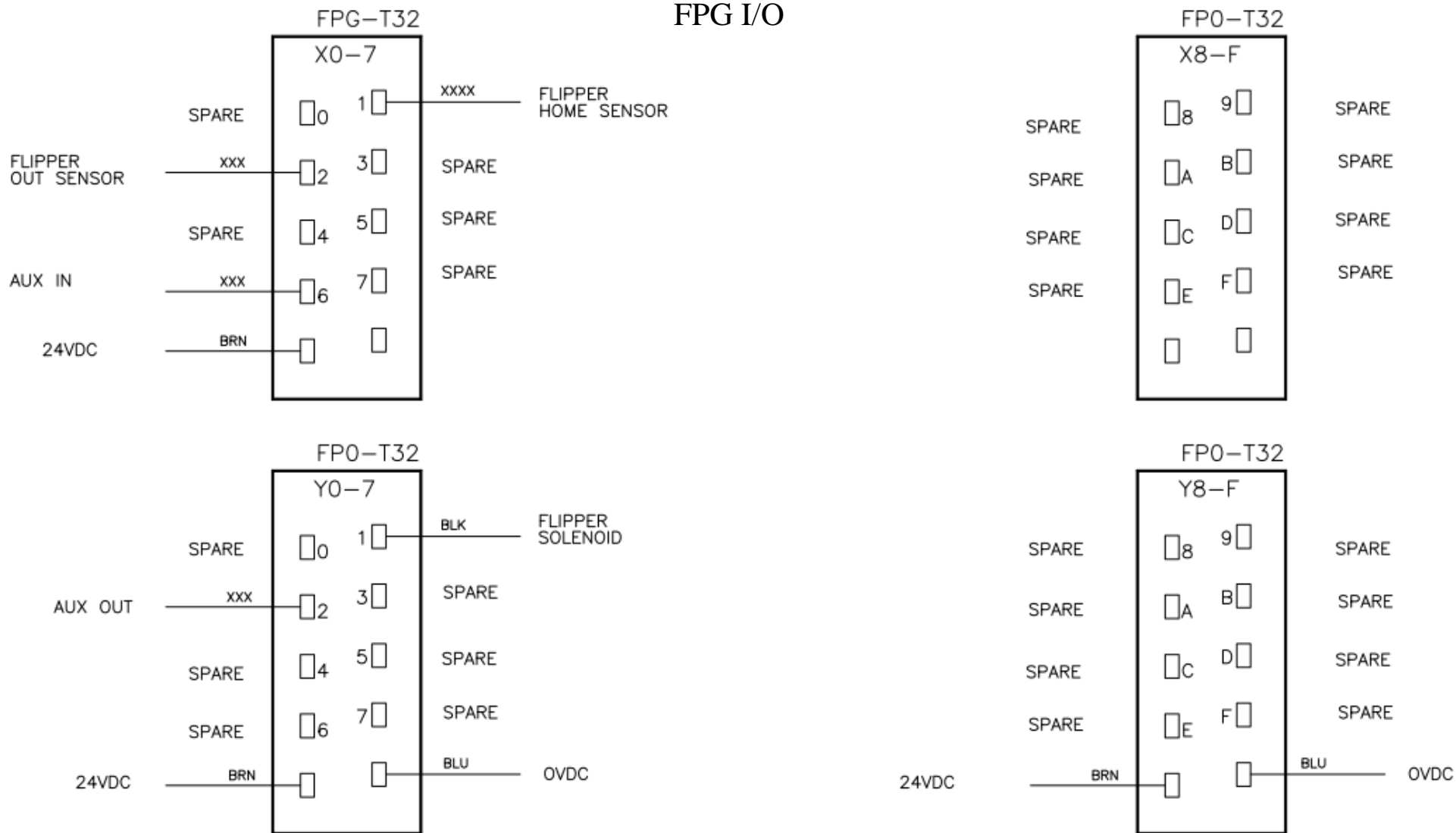

# Electrical Drawing

## EZ Light

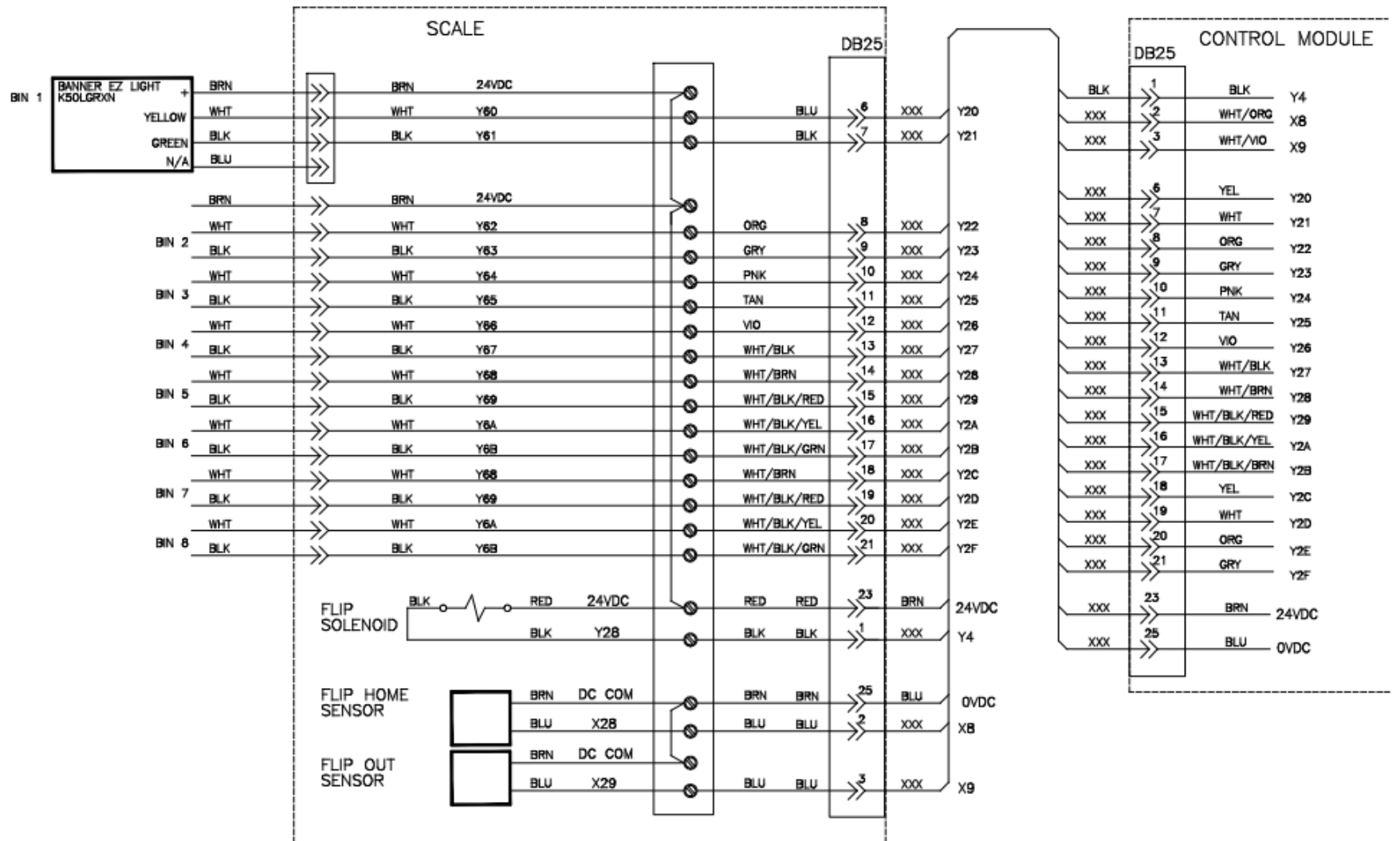

# Electrical Drawing

## TUS5k-E4\_Link 3

