

Ultra-Count™ 2400 and 3000 Parts Counter

Operation Guide, Version 4
Setup, Operation and Parts Manual

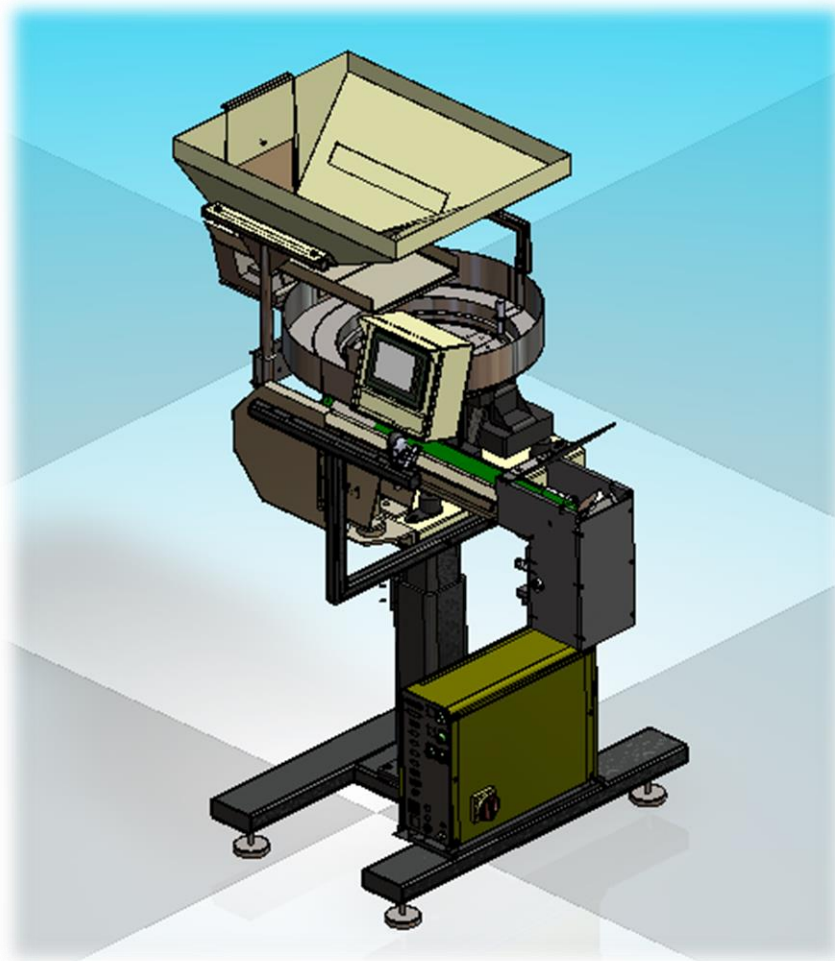

 **Advanced
Poly-Packaging, Inc.**

1331 Emmitt Road • Akron, OH 44306 • 1-800-754-4403 • fax 330-785-4010 • www.advancedpoly.com

Acknowledgments

Written By: Jen Sprandel

Completed and Edited By: Annie Braddock

Reviewed By: Stuart Baker

Copyright

© 2000 (Ver. 1), 2003 (Ver. 2), 2013 (Ver. 3) 2014 (Ver. 4) Advanced Poly-Packaging, Inc. (APPI). All rights reserved.

This manual and the program operating the equipment described in it are copyrighted. You may not copy this manual in whole or part without written consent of Advanced Poly-Packaging, Inc.

All information pertaining to the promotion, sale, distribution, operation and maintenance of the Ultra-Count 2400 and Ultra-Count 3000 Parts Counter including this manual, drawings, schematic, wiring diagrams, VHS video tapes, brochures, specification sheets, figures, charts or any other information, due to its proprietary design and manufacture, remain the property of Advanced Poly Packaging, Inc. Unauthorized duplication, distribution or disclosure to third parties without the express permission of Advanced Poly Packaging, Inc. is strictly prohibited.

Trademarks

Ultra-Count is a trademark of Advanced Poly-Packaging, Inc. Advanced Poly-Packaging, Inc. also owns the following trademarks: T-1000, Advanced Poly-Bags, Twin-Seal, Advanced Poly-Pack, Advanced Poly-Bag, Blist-a-Bag, Ultra-Feed, Flip-Series, Seal-a-Print, Roll-a-Print.

Warranty

Warranty period is one year. The warranty commences on the date of delivery of the equipment to the purchaser. APPI warrants to the Purchaser that the equipment is free from defects in workmanship or material under normal use and service. During the warranty period, APPI agrees to repair or replace, at its sole option, without charge to Purchaser, any defective component part of the equipment. To obtain service, Purchaser must return the equipment or component to APPI or an authorized APPI distributor or service representative in an adequate container for shipping. Any shipping charges, insurance, or other fees must be paid by Purchaser and all risk for the equipment shall remain with Purchaser until such time as APPI takes receipt of the equipment. Upon receipt, APPI, the authorized distributor or service representative will promptly repair or replace the defective component and then return the equipment or component to Purchaser, shipping charges, insurance and additional fees prepaid. APPI may use reconditioned or like new parts or units, at its sole option, when repairing any component or equipment. Repaired products shall carry the same amount of outstanding warranty as from original purchase. Any claim under the warranty must include a dated proof of delivery. In any event, APPI's liability for defective components or equipment is limited to repairing or replacing the components. This warranty is contingent upon proper use of the equipment by Purchaser and does not cover: expendable component parts such as print heads, rollers, bushings, and the like; or if damage is due to accident, unusual physical, electrical or mechanical stress, neglect, misuse, failure of electric power, improper environmental conditions, transportation, tampering with or altering of the equipment, packaging of corrosive or contaminating products or other products damaging to components, and equipment or components not owned or in the possession of original Purchaser. APPI will not be liable for loss of production, profits, lost savings, special, incidental, consequential, indirect or other similar damages arising from breach of warranty, breach of contract, negligence, or their legal action even if APPI or its agent has been advised of the possibility of such damages or for any claim brought against the Purchaser by another party. This warranty allocates risks of equipment failure between Purchaser and APPI. APPI's pricing reflects this allocation of risk and the limitations of liability contained in this warranty. The warranty set forth above is in lieu of all other express warranties, whether oral or written. The agents, employees, distributors and dealers of APPI are not authorized to make modifications to this warranty, or additional warranties binding on APPI. Accordingly, additional statements such as dealer advertising or presentations, whether oral or written, do not constitute warranties by APPI and should not be relied upon. Warranty on equipment is considered void when outstanding balances become delinquent (over 30 days late - 60 days after ship date). Equipment Integration to other Equipment: APPI assumes no responsibility for the integration of its products to other products or within a system unless APPI performs the integration, testing and provides the results of the tests to the purchaser in writing. Furthermore, APPI assumes no responsibility for bag sizing whether suggested or recommended.

TABLE OF CONTENTS

Chapter 1: Introduction	6
1.1 Welcome.....	7
1.2 Using This Manual.....	7
1.3 Specifications.....	7
1.4 Available Options.....	8
1.5 Warranty Registration.....	9
Chapter 2: Getting Started	10
2.1 Chapter Summary.....	11
2.2 Unpacking and Setup.....	11
2.3 Safety, Risks.....	11
2.4 Machine Setup.....	12
2.5 Hookups and Connections.....	12
2.6 Operating Environment.....	13
2.7 Air and Power Requirements.....	13
2.8 Turning on the Power.....	13
Chapter 3: Touch Screen Operation	14
3.1 Chapter Summary.....	15
3.2 Panel LEDs.....	15
3.3 System Settings and Function Keys.....	15
3.4 Screen Contrast Settings.....	15
3.5 Auto Screen Off / Manual Screen Off.....	15
3.6 System Settings: Parameter and Communication Settings.....	15
3.7 Touch Screen Program.....	16
3.8 Password Functions / Default Pass Codes.....	16
3.9 Introduction Screen.....	17
3.10 Counter Main Menu.....	17
3.11 Counter Operation Screen.....	17

3.12	Counter Settings Screen	18
3.13	Hopper Settings	20
3.14	Eye Test / Eye Settings.....	20
3.15	Counters Screen.....	22
3.16	Job Save Screen.....	23
3.17	Production Screen	24
3.18	Counter Auxiliary Options Screen	24
3.19	Technical Assistance Screen	25
3.20	Password Setup Screen.....	25
3.21	PLC I/O Status Screen.....	26
3.22	Counter APPI Factory Screen	26
3.23	Counter Factory Settings	26
3.24	Counter Operation Mode.....	27
3.25	Machine Info	27
3.26	Information Screens	28
Chapter 4: Adjustments, Maintenance, Troubleshooting		30
<hr/>		
4.1	Bowl Discharge Position.....	31
4.2	Skivers.....	31
4.3	Drop Gate	31
4.4	Level Switch.....	31
4.5	Bowl Drive	32
4.6	Erratic Feeding of the Bowl	32
4.7	Dead Spots in the Bowl.....	32
4.8	Adjustment of the Coil Gap	32
4.9	Spring “Tuning”	33
4.10	Belt Tracking.....	33
4.11	Accumulator Funnel Adjustment	33
4.12	Optical Frame Pot Settings.....	34
4.13	Height Adjustment	34
4.14	Troubleshooting Checklist for Ultra-Count Systems	35
4.15	Troubleshooting: Base / Bowl Drive Unit.....	36
4.16	Troubleshooting Checklist (Conveyor Feed Problems).....	37

4.17 PLC IO Listing	37
Chapter 5: Parts and Drawings	38
<hr/>	
5.1 Ultra-Count 2400.....	39
5.2 Electronics Assembly	41
5.3 Cable Assemblies	43
5.4 V-Track Assembly, Long	45
5.5 Touch Screen Assembly	53
5.6 Accumulator Funnel Assembly	57
5.7 Optical Eye Assembly	59
5.8 Supply Hopper Assembly.....	61
5.9 CCW Vibratory Bowl Assembly.....	63
5.10 Prox Sensor Assembly	65
5.11 Ultra-Count Stand	67
5.12 Ultra-Count 3000 System Layout	69
5.13 UC-3000 Stand Assembly	71
5.14 UC-3000 Supply Hopper Assembly.....	73
5.15 30 Inch Counter Clockwise Bowl Assembly	75
Appendix 82	
<hr/>	
A. Ultra-Count System Detailed Setup Procedure	83
I. Counter Setup.....	83
II. Procedure	83
III. Troubleshooting Inaccurate Counts.....	86
IV. Setup Procedure Summary	87

This page intentionally left blank.

Chapter 1: Introduction

Welcome

Using this Manual

Specifications

Available Options

Warranty Registration

1.1 Welcome

Thank you for selecting the Ultra-Count™ 2400 or 3000 Parts Counter. Designed to accurately sort and count various molded, medical, industrial and food products, the Ultra-Count™ will lower your packaging costs with automatic operation, increased speeds, versatility, reliability and simplicity.

1.2 Using This Manual

The following manual conventions are frequently used to assist in understanding important information, to alert the operator of potentially dangerous or damaging practices and to describe the normal functions of the Ultra-Count™ Parts Counter.

- Text Normal text.
- *Italics* Used for emphasis.
- **Boldface** Used to identify heading names and touch screen buttons.
- **CAUTION:** Warning messages. To avoid physical harm, damage to equipment or damage to the product, be sure to read these messages carefully.
- **NOTE:** Identifies important information.

1.3 Specifications

General

- Machine Dimensions: 54" high x 36" wide x 42" deep
- Conveyor Motor: Stepper drive
- Optical Frame: 80mm x 120mm staggered emitter / receiver
- Weight: Approximately 400 lbs. (varies based upon bowl and drive size)
- Air: 80 PSI
- Electric: 117V/60Hz

Touch Screen Specifications

- Power: 24 VDC (+/- 10%)
- Operating Environment: 0-50°C, 85% RH or less
- Display: Color LCD
- Resolution (W x H): 320 x 240 dots
- Display Area: 174 x 131mm (5.7")
- Backlight: CCFL
- Backlight Hours: Approx. 75,000
- PLC Connection: RS232
- Number of Characters: 40 columns x 30 lines max.

Touch Screen (Back Panel)

- MJ1: Connector used for serial communication with an external device and screen data transfer
- MJ2: Connector used for serial communication with an external device
- USB-A Port: Provides connection to a USB printer
- USB-B Port: Provides connection to a computer for screen data transfer
- LAN Connector (Optional): Provides Ethernet communication

Drive Specifications - Performance Data

- Part movement approaching 100 feet per minute is obtainable
- Overall Dimensions: 8 ¾" high, 16 ½" square base, 18" or 24" diameter bowl
- Weight: 222 pounds (drive unit less bowl)
- Power Required: 3.5 amps maximum amperage draw at 120 Volt AC, also available at 240 Volt
- Springing: 4 spring banks 90° apart, 15° spring angle
- Rotation: Counterclockwise or clockwise

- **Bowl Mounting:** One hole (or four holes on some models), top or bottom mount, bolt circles up to 16 ½"
- **Bowl Size:** Up to 30" stainless steel fabricated or cast aluminum
- **Operating Mode:** 7200 cycles per minute at 60 Hz; 50 Hz tuning available

1.4 Available Options

Although the UC-2400 and UC-3000 are extensively equipped with many “built-in” options, APPI offers some additional options that may better suit your Ultra-Count Piece Counting machine and your specific needs.

- **Bowl configurations:** The UC-2400 and UC-3000 come equipped with a flat track (or high-negative bowl) as a custom feature.
- **Vibratory hopper with leveling arm:** A supply hopper, triggered by a level switch designed to keep the bowl filled to a consistent level, provides a greater accuracy of parts flow. The leveling switch may be in the form of a leveling arm, an ultrasonic sensor or a photo optic sensor.
- **Incline feed conveyor and hopper with leveling arm:** A hopper with a floor level stand provides for lower filling of the hopper. An incline conveyor feeds the bowl and maintains a constant level in the bowl for greater feed accuracy.
- **FDA coating or rubber coating:** PTFE coatings are available for food contact. Rubber or polyurethane coatings are also available.
- **Special tooling:** Bowls can be custom-tooled to provide for the orientation requirements of special parts.
- **LAN connection:** Provides for Ethernet communication.
- **UF-2000 Takeaway Conveyor:** This conveyor removes the packaged product to a packing station or directly feeds a carton or table. Small, lightweight and equipped with castors, this conveyor can be used anywhere in the plant. Designed for 24 hour / 7 days a week operation.
- **Photo eyes:** APPI can provide different types and configurations of sensors to meet the specific needs of your product.
- **Recipe management system:** The Ultra-Count allows for a system with the ability to create, manage and store “recipes” of past jobs settings from multiple machines operating in a system. These recipes can be saved and applied to future jobs to make operation faster and easier.

1.5 Warranty Registration

This section must be completed and returned to Advanced Poly-Packaging, Inc. to register the scale for Warranty Protection.

Serial Number:

(Serial Number located on the back panel)

Company Name and Address

Contact Name(s) / Title(s) / Phone Number

<hr/>	<hr/>
<hr/>	<hr/>
<hr/>	<hr/>

Please fax or mail this page to:

Service Manager
Advanced Poly-Packaging, Inc.
1331 Emmitt Road
Akron, OH 44306
USA

Fax # (USA) 330-785-4010

Or email the information above to: sales@advancedpoly.com

Chapter 2: Getting Started

Summary

Unpacking and Setup

Safety, Risks

Machine Setup

Hookups and Connections

Operating Environment

Air and Power Requirements

Turning on the Power

2.1 Chapter Summary

This chapter describes procedures to receive and set up the Ultra-Count, including uncrating and assembly instructions, environmental, air and power requirements, and safety precautions.

2.2 Unpacking and Setup

The Ultra-Count System is typically shipped completely assembled on a pallet. However, photo eye or accumulating assemblies may be removed to various levels of disassembly. Cartons securing the electronic module, cables and manual will be also on the pallet. Remove all tape, banding or packing materials that secure the machine.

2.3 Safety, Risks

Many safety features have been included in the mechanical, electronic and pneumatic systems of this machine. Despite these safety precautions, operators may receive lacerations or crushed or broken bone injuries if they come in contact with any moving components. Improper use, improper adjustments and neglect of preventative maintenance may also result in serious personal injury. No special personal protective equipment is required to operate the equipment, but eye protection, gloves or other protection should be worn, depending on the characteristics of product being packaged or the method of loading the product.

Please carefully read the following precautions to operate the equipment properly and avoid injury:

- **CAUTION:** Initial setup of the machine must be performed by specialized personnel. Qualified service engineers should uncrate the equipment, assemble the equipment (if required), test and connect power sources, test the equipment for proper operation and set up the equipment for use.
- **CAUTION:** Do not attempt to adjust the height without assistance and without supporting the weight of the machine. Attempting to make a height adjustment without assistance could cause the machine to drop suddenly, causing severe injury. APPI offers several optional accessories that can reduce the risk of injury during height adjustments. These accessories include carts, motorized height adjustment components and stabilizing bars.
- **CAUTION:** Ensure that height adjustments allow for sufficient movement of the operator. Improper height adjustments could negatively affect operator movement, causing strain, added stress, discomfort and fatigue.
- **CAUTION:** To avoid injury, do not operate the equipment if funnels, guards, covers or other access panels have been removed. If any of these safety measures have been removed or modified or if any openings have been increased, the operator will have access to moving components that can cause crush, cut or burn injuries to hands or fingers.
- **CAUTION:** To avoid injury, do not reach under guards or elsewhere under the machine.
- **CAUTION:** Do not remove or loosen fasteners on the frame. If loosened, the equipment may drop suddenly, causing injury or damage to the machine.
- **CAUTION:** To avoid injury, avoid coming in contact with pinch points including rollers, automatic funnel doors or other moving components.
- **CAUTION:** Exercise care when adjusting or relocating the touch screen. Movement of the touch screen could cause unexpected movement of the machine and injury to the operator.

- **CAUTION:** Do not attempt to feed parts that are not suited to the machinery. Doing so could cause jams, damage to machinery and ejection of parts. For example, parts too large for the accumulating funnel may jam and eject when the door closes.
- **CAUTION:** If control or air pressure settings are set too high, higher noise levels may result from increased part on part contact or part on machinery contact. Limit these settings and add guards or covers to reduce airborne noise.
- **CAUTION:** Exercise extreme care when clearing jams, replacing materials, changing controls or mechanical settings, and cleaning internal parts. Be sure to de-energize energy sources prior to removing guarding. Failure to do so may result in unexpected movement or flying objects, which could cause crush, cut or eye injuries.
- **CAUTION:** Maintenance must be performed by specialized personnel. Qualified service engineers must remove guards or covers to gain access to electrical or mechanical areas.
- **CAUTION:** Maintenance must be performed regularly to ensure that the machine is operating properly and to protect against injury. Routine maintenance includes: periodic inspections, the replacement of worn or damaged components, the tightening of loose bolts or components, and regular cleaning and adjustments. Contact APPI and/or service centers for service support if there is not sufficient maintenance staff at the user facility to perform regular maintenance.

2.4 Machine Setup

First, position the stand in its operating location. Then, with a lift truck or other lift device, position the drive unit onto the stand, locating the feet in their mounting pads or mounting holes. Check the unit to make sure the four rubber feet are securely attached to the base of the unit. It is essential that these feet are in good condition and are securely attached to the base. The rubber mounting feet will isolate the slight vibrations of the drive unit from the mounting structure. Mounting screws restrain the drive unit from moving. Secure the feeder bowl to the top plate of the drive unit with the screws provided. Mount or position the electronic module so that the cables reach the connections.

NOTE: The base drive may not be bolted to the stand. Do not attempt to move the counter while the base drive is positioned on the stand. Remove the feeder bowl, then the base drive, prior to repositioning the stand.

NOTE: Erratic parts feeding will occur if the bowl mounting screws are not drawn down tightly or if the screws become loose.

2.5 Hookups and Connections

The back of the Ultra-Count control module has eight clearly marked ports:

PORT	CONNECTION
Belt Drive	Military Connector, 10 Pin Female, Belt Drive
Bowl Drive	Military Connector, 3 Pin Female, Base Drive
Level Input	DB9F, 9 Pin Female, Leveling Switch
Optical Input	DB9F, 9 Pin Female, Optical Frame
IOP Serial Port	5 Pin Female, Touch Screen Operator Panel
Hopper	110 Outlet, Line Out, Vibratory Hopper
Aux In	Military Connector, 7 Pin Male, Aux. In Signal (from bagger/conveyor)
Aux Out	Military Connector, 6 Pin Female, Aux. Out Signal (to other counter, bagger, check weigh scale or terminator)

2.6 Operating Environment

When you choose a location for installation, make sure the area is free of excess dust, dirt and moisture. To ensure the highest production possible, consider product flow to the counter and ensure that the finished (packaged) product can easily flow from the system.

NOTE: For suggested system layouts, please contact an APPI technical sales person for layout drawings.

2.7 Air and Power Requirements

The Ultra-Count is equipped with an external regulator, and the air supply should be fed to the UC-2400 or UC-3000 with ¼" O.D. poly tubing. Make the connection at the rear of the machine. Set the air pressure on the UC-2400 / UC-3000 between 20 and 40 PSI.

NOTE: Air should be dry and oil free.

The UC-2400 and UC-3000 require an 115V/50Hz dedicated power source and will draw 15 amps total per unit.

2.8 Turning on the Power

The main power switch is located on the control module at the base of the machine. To turn the machine on, turn the switch clockwise from its horizontal OFF position to its vertical ON position. The green Power light on the touch screen will illuminate and the Introduction screen will be displayed. The program version will also be identified. The Introduction screen will only appear for a few seconds until automatically changing to the Operation screen or Main Menu.

Chapter 3: Touch Screen Operation

Summary

Panel LEDs

System Settings and Function Keys

Screen Contrast Settings

Auto Screen Off / Manual Screen Off

System Settings: Parameter and Communication Settings

Touch Screen Program

3.1 Chapter Summary

The touch screen is comprised of LEDs, system and function buttons and the screen operation itself. This chapter describes the identification, operation and settings of the touch screen program.

3.2 Panel LEDs

Power: Green LED is lit when machine is turned on.

Run: Green LED is lit when touch screen is in run mode and the program is operating properly.

3.3 System Settings and Function Keys

There are three levels of access to the System Settings:

- 1) Press **Function keys** (F1 to F5) directly.
- 2) Press the **System key** first, and then press the **Function keys**.
- 3) Press the **System key**. Then hold down the **F1** and **F5 keys** for parameter settings.

The **System key** and **Function keys** are located to the right of the touch screen. **Function keys** are programmed as “hot” keys and may be changed depending upon the program version. However, the **F1** key displays a HELP screen. **F5** displays a password screen.

3.4 Screen Contrast Settings

To access the Screen Contrast Settings, press the **System key** first, and then press the **Function keys**.

Pressing the **System Key** followed by **F2** through **F5** allows for screen contract adjustments, as follows:

- **F2** - Function key 2: Reduces the screen contrast.
- **F3** - Function key 3: Sets the screen contrast to mid-scale.
- **F4** - Function key 4: Increases the screen contrast.
- **F5** - Function key 5: Backlight ON/OFF (locked in ON position).

The contrast control for the Ultra-Count is accessed through the **Function keys**. To enable the **Function keys**, press the **System key**. Hold down the **F2** key or depress it repeatedly to *decrease* the contrast and darken the touch screen display. Hold down the **F4** key or depress it repeatedly to *increase* the contrast and brighten the touch screen display. Press the **F3** key to set the contrast to the mid-scale position. Press the **System key** again to disable the function keys.

NOTE: The function keys will only remain active for 5 seconds after the last key is pressed.

3.5 Auto Screen Off / Manual Screen Off

The backlight will automatically turn off after 30 minutes of nonuse of the touch screen for longevity of the screen components. If the backlight is off, simply touch the screen or press the **System** or **Function key** to illuminate the screen. To turn off the backlight manually, press the **System key**, followed by the **F5** function key. Again, pressing any key or the touch screen will illuminate the screen.

3.6 System Settings: Parameter and Communication Settings

System settings can only be accessed by pressing the **System key** and then holding the **F1** and **F5** function keys simultaneously. System settings provide access to the COMM parameters, I/O Test and memory card information.

NOTE: Parameter settings are set at the factory and should not be altered. Any changes may cause the touch screen to become inoperative.

COMM parameters are set at the factory as follows:

- SIG LEVEL: RS232C
- CONNECT: 1:1
- PC Stat: No: 1
- Baud Rate: 19,200
Data: 8
- Stop Bit: 1
- Parity: ODD

The I/O test provides for Touch / Contact Switch tests. Each button can be tested to ensure proper operation of the screen. Press the right corner of the screen to return to the Main Menu.

From the Main Menu, press **System / Mode** to return to normal operation.

3.7 Touch Screen Program

The touch screen program is a user-friendly, menu-driven setup and operation program. To move through the system, touch the area of the screen that describes the desired operation. A particular color scheme is used to identify functions:

- **Blue** is the background color used for text information. No “buttons” or functions are blue.
- **Green** is the color used for “buttons” that change settings. For example, pop-up windows may be displayed or a function turned on/off when a green button is pressed.
- **Red** indicates that a function is off or stopped. For example, pressing a red button may turn a function on.
- **Yellow** is the color used for menu buttons. A menu button displays another screen and allows for movement throughout the entire program.

3.8 Password Functions / Default Pass Codes

APPI has included a pass code function in all touch screen equipment to prevent operators from changing settings.

There are two pass code levels, described as follows:

1. **Level 1:** This is the highest level pass code. It prevents operators from accessing the technical assistance functions of the machine. Additionally, the pass codes are maintained in this area.
2. **Level 2:** This level pass code, when the pass code function is enabled, prevents the operator from accessing settings screens that affect the operation of the equipment.

Pass codes prevent unauthorized individuals from tampering with settings. When equipment is shipped, APPI uses the following codes that can be changed by the customer at any time:

1. **Level 1 pass code:** 1001
2. **Level 2 pass code:** 1002

To enable the pass code function, press the **Technical Assist** button on the Main Menu. Enter the Level 1 pass code (1001 by default from APPI). Then press the **ON/ OFF** toggle button to toggle the pass code function ON. If you change the pass codes, ensure that these codes are written down.

Once the pass code function is enabled, the operator will have a programmed amount of time (time-out time) to make changes. Once this time has elapsed, the Counter Operation screen will automatically be displayed. This time can be changed by accessing the Password Setup Screen. By default, the time is set to five minutes.

If you misplace or forget the pass codes, contact the APPI Service Department for assistance. APPI will provide a “factory code” so that the current pass codes can be displayed. Once you receive the factory code, press the **F5** function key, located to the right of the touch screen, to enter the factory code and display your preset codes.

NOTE: Refer to the section 3.20 Password Setup Screen for further information on this function.

3.9 Introduction Screen

When the Ultra-Count is turned on, an Introduction screen is “flashed” on the screen momentarily. See Figure 3-1.

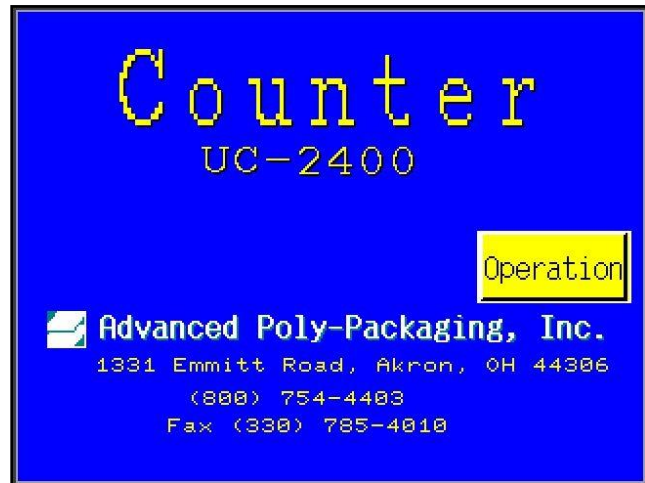

Figure 3-1

3.10 Counter Main Menu

The Counter Main Menu screen allows the operator to navigate quickly through the entire program. See Figure 3-2.

The yellow buttons located in the center of the Main Menu screen are menu command buttons. Pressing one of these buttons will change the screen currently displayed on the IOP. To access another screen, simply press the corresponding menu command button. Menu buttons appear throughout the touch screen program to assist in navigation and are normally located on the right side of the screen.

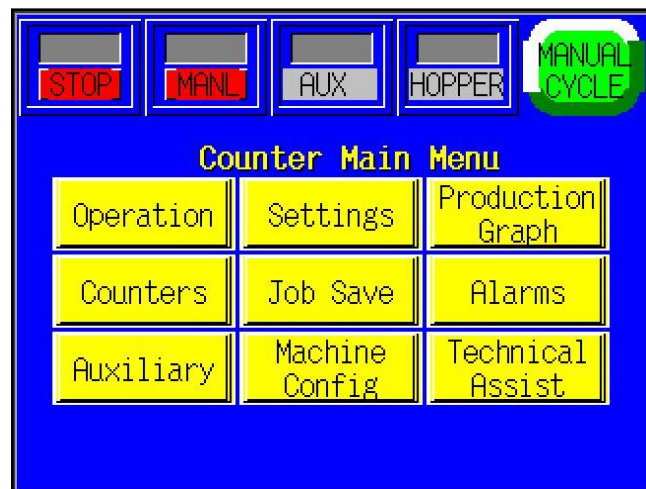

Figure 3-2

3.11 Counter Operation Screen

The Counter Operation screen allows the operator to monitor operation, begin operation and stop the system from running. See Figure 3-3.

Top line toggle switches appear on most screens throughout the program. These toggle switches include the **RUN/STOP** button, **MANL/AUTO** button, **AUX** button and the **HOPPER** button.

- **RUN/STOP:** This toggle button changes the current state of the counter’s operation. To start the counter, toggle the button to RUN. To stop the counter, toggle the button to STOP.



Figure 3-3

- **MANL/AUTO:** This toggle button switches operation to Manual or Automatic mode. In Automatic mode, the counter will cycle in a continuous mode (if AUX is OFF) or in a closed loop communication mode (if AUX is ON). To run with a bagger or conveyor, this switch must be in the AUTO position. In Manual mode, the operator must press the **Manual Cycle** button to cycle the machine.
- **AUX:** To set up communication with the bagger, conveyor or other equipment (including the CW scale), the **AUX** toggle button must be in the green ON position. If you wish to operate the unit as a standalone machine, then the **AUX** toggle button must be in the grey OFF position. For setup, place the **AUX** button in the OFF position.
- **HOPPER:** If equipped with a hopper or hopper/conveyor system, the toggle button must be in the green ON position. However, even in the ON position, the hopper will turn on only if the bowl is in fast operation mode and the leveling switch is ON. To turn the hopper OFF, toggle this button to the grey OFF position.

Manual Cycle: Press this button to manually cycle the counter. If the final count has been reached, the unit should cycle. Before running the counter in a “system,” the counter should be cycled several times as a standalone unit to test parts flow and count accuracy. The **Manual Cycle** button can be pressed any time during the count sequence.

The Counter Operation screen displays the preset number of batch counts before operation will stop, displayed in the right box under **Count**, the remaining number of batch counts, displayed in the left box under **Count**, and the total number of parts processed during the cycle, displayed under **Total Parts**. A message will be displayed when the preset count has been reached. Pressing the **Reset** button will zero the Totals Parts count. The status of the accumulator, bowl and hopper are also displayed on this screen.

Accum serves as an indicator for the status of the accumulator. When CLOSED is displayed, the accumulator is in Closed mode. When OPEN is displayed, the accumulator is in Open mode.

Bowl Speed serves as an indicator for the status of the bowl. When STOP is displayed, the bowl is off. When RUN is displayed, the bowl is on.

Hopper serves as an indicator for the status of the hopper. When HOPPER displays STOP, the hopper is off. When HOPPER displays RUN, the hopper is on.

If the pass code function is enabled, the Operation screen will automatically be displayed after the password timeout period, which can be adjusted on the Password Setup Screen, has expired.

3.12 Counter Settings Screen

The Counter Settings screen contains all the timer settings, count settings and speed settings used to control the operation of the counter. Pressing a button on this screen will display a numeric keypad that allows the operator to change the setting value. Enter the value and press the **ENT** button to accept the value. If entered incorrectly, press the **CLR** button, then reenter the value. The LEDs on these buttons indicate whether or not the function is turned on. See Figure 3-4.

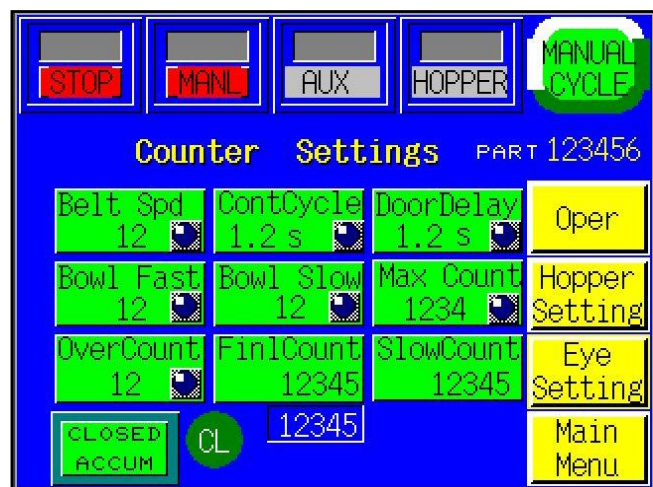

Figure 3-4

Belt Speed: The **Belt Spd** button displays the current belt speed. To change the Belt Speed, press the **Belt Spd** button and change the value using the numeric keypad. The minimum and maximum values for each parameter are indicated in white to the right of the numeric pad. Use the numeric pad to enter a new value for the Belt Speed and press the **ENT** button. The Belt Speed will change only after the next cycle operation begins.

NOTE: Values below the minimum value or above the maximum value will not be accepted when the ENT button is pressed. Press the CLR button and enter a new value that is acceptable.

NOTE: Overcounts may occur if parts continue to travel through the optical frame after the belt stops. If parts on the belt continue to move after the belt stops, the Belt Speed may need decreased.

Bowl Fast / Slow: The **Bowl Fast** and **Bowl Slow** buttons display the current fast bowl speed. The bowl speed changes immediately after pressing **ENT** on the numeric keypad, if the value has been changed. Two speeds are provided in order to increase production and accuracy. The fast speed is used to reach the final count quickly, and the slow speed is used for accuracy.

NOTE: Overcounts may occur if the bowl is feeding parts onto the belt too closely, causing the optical frame to count two parts as only one. Slow the fast and/or slow bowl speeds down to avoid overcounts.

Overcount Setting: The Overcount setting is provided to stop the system if an Overcount condition exists. To enable this feature, press the **OverCount** button and use the numeric keypad to set the Overcount to one or higher. To disable this feature, set the Overcount setting to zero. If set to one, the cycle operation will stop and a message will appear on the screen, indicating an Overcount condition (an Overcount of one or higher). To continue operation, touch anywhere on the screen.

Final Count Setting: Press the **FinlCount** button to set the Final Count value to the desired count. Once the Final Count is reached, the cycle operation will stop and await a signal to drop the parts.

Slow Count Setting: Press the **SlowCount** button to set the Slow Count to a value that causes the bowl (and/or belt) to slow down when the counter approaches the Final Count. The Slow Count setting helps prevent extra parts from being counted. For small value counts (such as 1 through 5), the Slow Count value may be set to the Final Count value since the bowl will be running more slowly for smaller counts. To determine the Slow Count setting, first set the value to 80% of the Final Count and adjust after testing.

NOTE: The difference between the Final Count and Slow Count settings must be greater than the number of parts on the V-track belt at any one time.

Door Delay: Door Delay is the amount of the time the accumulator door remains open before it closes. This allows the batch quantity of parts to fully escape the accumulator before it closes.

Cont. Cycle Setting: The Continuous Cycle timer provides a delay time if the counter is running in a standalone mode and automatic mode. The operator can keep pace with the counter and, if needed, increase the Continuous Cycle counter to slow down the operation.

Max Count: Press the **Max Count** button to adjust the maximum number of parts that can be in the accumulator. Adjusting this number will help avoid overfilling the accumulator. To disable this function, set the Max Count to zero.

Open / Closed Accumulator: In Closed Accumulator mode, the Final Count will be reached with the accumulator doors closed. In Open Accumulator mode, the Final Count will be reached with the doors open, and the doors will close as soon as the Final Count has been reached. There is an accumulator button on the Counter Settings screen that allows for adjustment of this mode. If the accumulator button

displays Closed Accum, pressing the **Closed Accum** button will change the accumulator mode from closed to open, and the button will then display Open Accum. If the accumulator button displays Open Accum, pressing the **Open Accum** button will change the accumulator mode from open to closed, and the button will then display Closed Accum.

3.13 Hopper Settings

The Hopper Settings screen allows for adjustment of the hopper settings, including speed and on and off time. See Figure 3-5.

Hopper Spd: Press this button to enter a numeric value and adjust the speed of the hopper that distributes parts to the vibratory bowl.

NOTE: The higher the number, the faster the hopper will vibrate to distribute the parts to the bowl more quickly.

On Time: The amount of time the hopper will continue distributing parts to the bowl after the proximity sensors tell the hopper it is full.

Off Time: The amount of time the hopper will remain resting until it is turned on again.

Level Sensor: The **Level Sensor** toggle button controls the style of sensor that is used in operation. Typically, the Level Sensor should remain on DARK and should not be adjusted during operation.

There are three LED indicators on this screen that help troubleshoot the hopper:

- **Bowl Run:** Indicates whether or not the bowl is running.
- **Level Input:** If this LED is on, input is low. If this LED is off, input is high.
- **Hopper Run:** Indicates whether or not the hopper is feeding into the bowl.

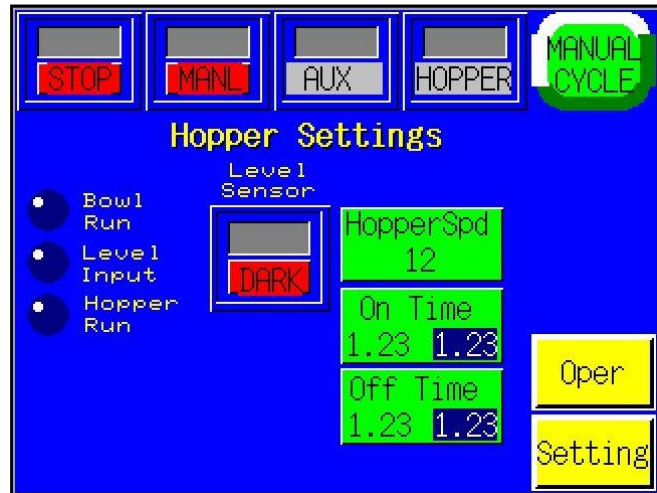

Figure 3-5

3.14 Eye Test / Eye Settings

The Eye Test must be performed prior to full operation in order to obtain the minimum length and maximum length of the part to be counted when passing through the eye. The purpose of this is to a) ensure scrap pieces of parts or materials are not counted as a part and b) ensure two parts passing through the eye are not counted as one part. See Figure 3-6.

To perform an Eye Test, turn off the vibratory bowl while leaving the belt running. Neither the bowl nor the hopper can run while an Eye Test is performed. Press the **Eye Test** button from the Eye Settings screen (See Figure 3-7) and follow the instructions. Randomly drop parts onto the belt. Parts must be loaded

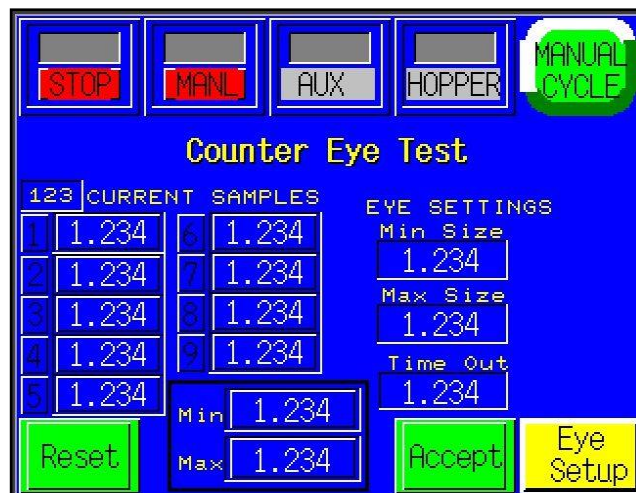

Figure 3-6

manually. The counter will begin counting and measuring the parts. The test will display the last nine counts only and will take the lowest and highest lengths of the tested parts. These will be your minimum and maximum sizes, which are displayed at the bottom of the Counter Eye Test screen after each test.

Minimum Size: The minimum size is used to filter scrap. For example, if, through testing, the minimum value detected was 0.2, setting the value to 0.1 would cause parts that are 0.1 or less to not be counted. If the minimum setting is too close to the actual minimum test value, however, some parts may not be counted, causing overcounts. Setting the minimum setting to zero will cause all parts to be counted.

Maximum Size: The maximum size is used to count parts connected or parts falling through the eye together (overlapped) as two parts. For example, if, when testing the parts length, the maximum value was determined to be 0.5, you could set the maximum setting to 0.8. Then, if two parts overlapped through the eye with a size of 0.9, they would be counted as two parts. However, if you set the maximum setting too close to the maximum value, one part may be counted as two, causing undercounts. To disable this function, set the maximum value to zero.

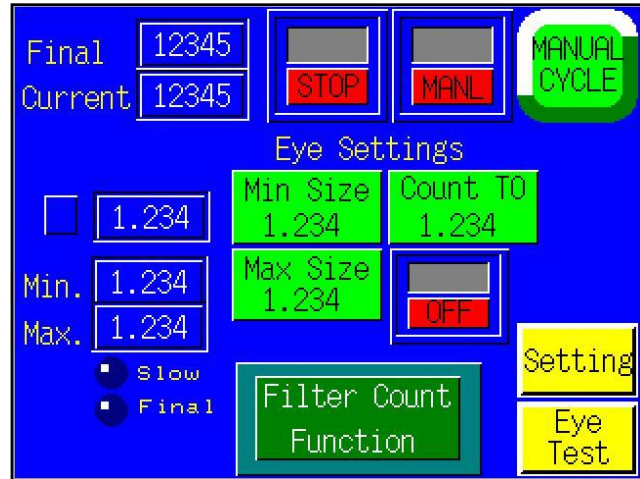

Figure 3-7

NOTE: Min and Max are NOT the same as Min Size and Max Size. Min and Max display the results of each eye test. Min is the smallest size recorded during the test and Max is the largest size recorded during the test. The values for Min Size and Max Size are determined through a formula based on the results of the eye test, and they function as part of the eye settings and affect operation. Min Size is 80% of the Min measurement. Max Size is 160% of the Max measurement.

If Min and Max do not change after performing multiple eye tests, press the **Accept** button to accept those settings, which will then be displayed on the Eye Settings screen. Pressing the **Reset** button will zero the Current Samples values. To manually enter minimum and maximum settings, press the green **Min Size** and **Max Size** buttons on the Eye Settings screen. Enter a value into the numeric keypad and press **ENT**.

For more detailed information on eye testing and eye settings, refer to the Detailed Setup Procedure in the Appendix.

Time Out: Time Out is located on the Eye Test screen, and it displays the period of time the eye does not take a measurement while reading a part. Time Out is automatically calculated. It is 80% of the Max measurement.

Count To: The **Count To** button allows the operator to adjust the Time Out setting. Press the **Count To** button and enter a value on the numeric keypad to change the Time Out setting.

Final and Current on the Eye Settings screen display the count. Final is the preset number. Current is the count the machine is processing.

Pressing the large green button that displays either **Small Parts Function** or **Filter Count Function** will display a Counting Change Mode message. Press the message to return to the Factory Settings screen. The button will have changed to either **Small Parts Function** or **Filter Count Function**, depending on what the button displayed initially. Press **Filter Count Function** to change the counting mode from Filter Count Function to Small Parts Function. This will zero the Eye Settings. Press **Small Parts Function** to

change the counting mode from Small Parts Function to Filter Count Function. This will start an Eye Test that will set minimum and maximum size.

Setting the counting mode to Small Parts Function allows the PLC to detect small inputs from the eye faster and more reliably. The Small Parts Function causes the eye to read every part, regardless of the size, as one part. For example, if a toothpick and a pencil pass through the eye, the toothpick would be counted as one part and the pencil would be counted as one part, despite their different lengths and widths.

The Slow LED displays when the counter reaches the Slow Count. The Final LED displays when the counter reaches the Final Count. For example, if the operator has set the Final Count to 50, meaning the counter will stop operation once 50 parts are counted, and the Slow Count to 40, meaning the bowl and/or belt will slow down for the last ten counts to ensure counting accuracy, the Slow LED will display when the count reaches 40 and the Final LED will display when the count reaches 50.

ON / OFF button: The **ON / OFF** button on the Eye Settings screen controls the Double Count function, a function that automatically adds a count if the eye's measurement exceeds the maximum size. For example, if the maximum size is set to 0.04 and the eye reads a part as 0.05, the 0.05 measurement would be counted as two parts. To disable the Double Count function, toggle the **ON / OFF** button to OFF. This will set the Double Count setting to zero. If the Double Count function is turned off, an overcount condition may occur if parts are not properly separating when coming off the belt. To enable the Double Count function, toggle the **ON / OFF** button to ON. If the Double Count function is turned on, an undercount condition may occur if the maximum setting is too low and one part is counted as two parts. A message will be displayed after the **ON / OFF** button is pressed to inform the operator of the change in function.

If the eye is blocked for an extended period of time (parts jam), the machine will stop and a message will be displayed.

3.15 Counters Screen

The Ultra-Count is equipped with a start-up counter that allows for system startup (numerous counters), a batch counter that counts the machine cycles, a parts counter that counts the individual parts and a maintenance counter that cannot be reset. The Counters screen allows for adjustment of the Start-up Counter and the Preset Count. See Figure 3-8.

Start-up Counter: When in a system comprised of numerous parts counters feeding a compartment or bucket conveyor, the counter can be set up to begin operations when a preset number of "empty" compartments or buckets go by each counter "station." The counter will "wait" a predetermined number of cycles before it starts running. A station number can be set so that the counter will begin operation only after that preset number of input signals is received. Press the green button below Start-up and use the numeric keypad to set the station number. When the Start-up function is **ON**, the auxiliary communication is suspended until the Start-up count has been reached. When the count is reached, normal auxiliary communications resume and the Start-up function will automatically switch **OFF**. Additionally, when the Start-up function is first switched **ON**, the current start-up, counts, functions and batch values are reset to their respective set values. Pressing the **Reset** button will reset the Start-up value.

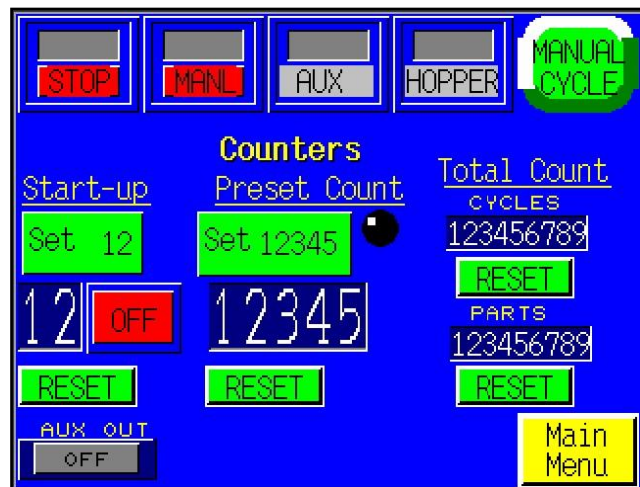

Figure 3-8

Preset Count: The number of parts desired in one “batch” or bag. Press the green button under Preset Count and use the numeric keypad to enter a preset value. Press **Reset** to zero this value. If the Preset Count is set to zero, the LED will turn off, indicating that there is no preset count. If the Preset Count is set to one or higher, the indicator light will turn on, indicating that a preset count has been set.

Total Count: The Cycles total shows how many cycles have occurred since the counter was reset. Press the **Reset** button to zero this value. The Parts total shows the number of parts that have run through the eye since the counter was reset. Press the **Reset** button to zero this value.

Aux Out: The **Aux Out** button will display either READY or HOLD (or OFF if there is no auxiliary equipment). When Aux Out displays READY, the counter is ready to drop parts. When Aux Out displays HOLD, the counter is still cycling.

3.16 Job Save Screen

The Ultra-Count is equipped with memory storage to save the settings for 96 different parts. A part number can be assigned to each part for easy reference. See Figure 3-9.

Job Save Function: When all settings have been created and tested, press the **Job Save** button, located on the Main Menu. A listing of jobs will be shown as follows:

- **No.:** Each column of the part save/recall screen is numbered and describes a memory address/order.
- **PN:** Enter a part number (up to six numbers) for your reference.

Counter Job SAVE/RECALL PAGE 1							
No.	PN	No.	PN	No.	PN	No.	PN
1	123456	9	123456	17	123456	25	123456
2	123456	10	123456	18	123456	26	123456
3	123456	11	123456	19	123456	27	123456
4	123456	12	123456	20	123456	28	123456
5	123456	13	123456	21	123456	29	123456
6	123456	14	123456	22	123456	30	123456
7	123456	15	123456	23	123456	31	123456
8	123456	16	123456	24	123456	32	123456

CURRENT JOB: Next Jobs Setting Menu
 LINE NO: 12 PN: 123456

Figure 3-9

To save a job to a memory address that has no settings saved, press the field located to the right of the number (No.). Enter a part number that you will reference at a later date.

NOTE: You can also save the settings over a previously saved job, but this will cause the previous settings to be lost.

Job Recall Function: To recall a job that has already been saved, press the field that has your part number displayed. Then press the **View** button to display the settings. See Figure 3-10. From this screen, you can run / load the job by pressing the **Load** button.

View Settings For Part No: 123456			
Belt Fast 12		Hopper Spd 12	CLOSED ACCUM
Bowl Fast 12	Bowl Slow 12	Hopper On 1.23	Max Cnt 1234
Door Del 1.2	Cont Cycl 1.2	Hopper Off 1.23	LOAD
OverCount 12	FinlCount 12345	SlowCount 12345	CLEAR
Count TO 1.234	Min Size 1.234	Max Size 1.234	Return

Figure 3-10

If you attempt to load a job that does not exist, a message will be displayed.

3.17 Production Screen

Press the **Production Graph** button on the Main Menu screen to display the Counter Production screen, which features a graph that shows the batches per minute performed over an eight-hour period. See Figure 3-11.

Press the left arrow key to scroll back one hour at a time to review past production. Press the right arrow key to check more recent production information.

Press the **Reset** button once to reset the production time and twice to reset the graph.

Press the **Prod Bags/m** button to display the Counter Production Chart. This chart displays the number of bags per minute produced. Pressing the **Prod Part/m** button returns the operator to the Counter Production screen.



Figure 3-11

3.18 Counter Auxiliary Options Screen

The Ultra-Count is equipped to operate within a system for fully automatic parts counting. From the Counter Auxiliary Options screen, the type of communications that match the equipment you are running the counter with can be set up. See Figure 3-12.

Option 1 or 2: This option is set at the factory to match the bagger, conveyor or CW scale the counter is connected to.

Continuous Cycle Timer: This causes a delay between cycles if the counter is running in standalone mode or during setup.

Aux Time Delay: This timer delays the output of the counter to allow the parts to settle once they have been dropped from the accumulating funnel of the counter. Increase this delay timer if the bagger is cycling before the parts are in the bag, for instance.

Aux Out: When **Aux Out** displays READY, the counter is prepared to drop parts to the auxiliary equipment. When **Aux Out** displays HOLD, the counter is still cycling. When **Aux Out** displays OFF, no auxiliary equipment is present.

Aux In: When **Aux In** displays READY, the auxiliary equipment (i.e. bagger) is prepared to operate. When **Aux In** displays HOLD, the auxiliary equipment is still cycling. **Aux In** displays OFF when no auxiliary equipment is present.

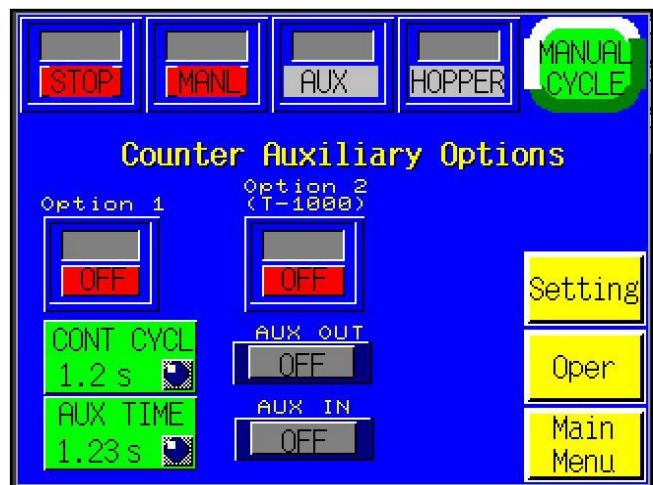

Figure 3-12

3.19 Technical Assistance Screen

The Technical Assistance screen provides for operator information, factory settings adjustments, functions testing and troubleshooting. The screen is protected from access with a Level 1 password. The password is set by default (from the factory) to 1001. This code can and should be changed when the system is put into operation. See Figure 3-13.



Figure 3-13

The Technical Assistance screen displays the current touch screen (TS) program version and programmable logic controller (PLC) versions. This information should be shared with an APPI service technician when requesting technical assistance. Contact information is also provided to receive technical service via phone or mail.

3.20 Password Setup Screen

The pass code function, as described in the beginning of this chapter, is provided to safeguard the settings from changes by unauthorized operators. See Figure 3-14.

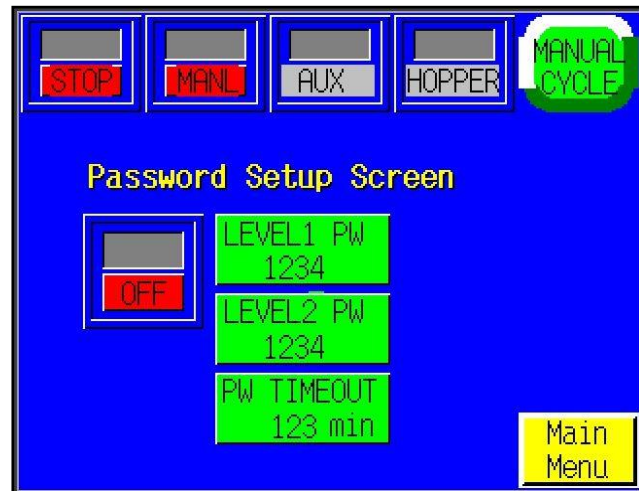

Figure 3-14

If this function is ON, the operator has a certain amount of time to make settings changes. After this set amount of time elapses, the Operation screen will be displayed and the operator will have to enter a pass code.

PW Timeout: To adjust the amount of time the operator has to make settings adjustments, press the **PW Timeout** button and enter a value using the numeric keypad.

The Level 1 pass code is always on, which protects only the settings that can be accessed from the Technical Assistance Screen. However, the Level 2 pass code, if enabled, safeguards the remainder of the equipment settings. See Figure 3-15.



Figure 3-15

3.21 PLC I/O Status Screen

The Ultra-Count inputs and outputs are illustrated on the I/O Status Screens. These screens assist in the troubleshooting of the equipment and assist APPI service technicians in helping operators or maintenance personnel. See Figure 3-16. During the cycle operation of the Ultra-Count, the input and output conditions are illustrated with LEDs. To determine what each LED indicates, press the row of LEDs. A short description is provided.

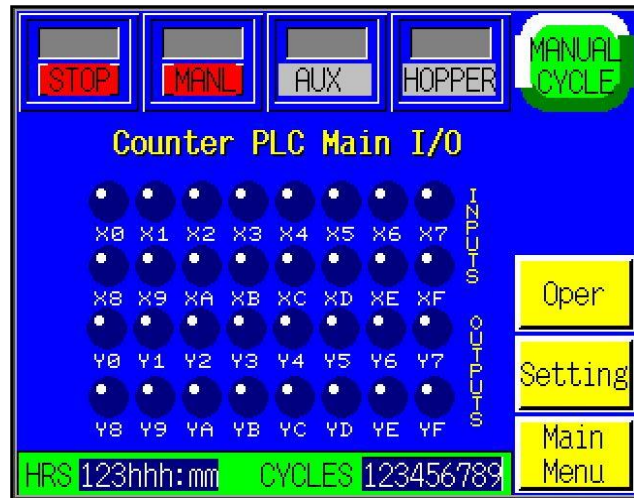

Figure 3-16

3.22 Counter APPI Factory Screen

The settings on this screen are additional settings that should only be set by qualified technicians or by the factory. See Figure 3-17.

3.23 Counter Factory Settings

The Counter Factory Settings screen displays additional counter settings that should only be set by qualified technicians or by the factory. See Figure 3-18.



Figure 3-17

Belt Time Out: Toggle this button to the ON position to run the Belt Off setting. This will turn

the belt off after a specified number of seconds that the eye does not detect any parts passing through it. This setting can be adjusted by pressing the **Belt Off** button and entering a value into the numeric keypad.

Alarm History: Toggle this button to the ON position to monitor the frequency of warning signals.

Small Parts Count: Displays the number of parts processed when the counter is set to Small Parts Function.

Filter Count: Displays the number of parts processed when the counter is set to Filter Count Function.

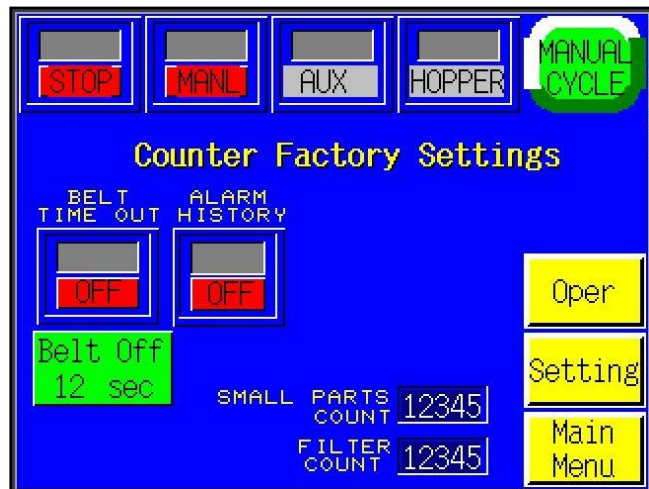

Figure 3-18

3.24 Counter Operation Mode

Pressing the **Alarms** button on the Main Menu screen takes the operator to the Counter Operation Mode screen, which displays the time and frequency of a particular operation. Alarm Status and Alarm Data can also be viewed from this screen. See Figure 3-19.

The Alarm Status window will give the status of a particular warning signal. The Alarm Data screens keep track of how long and how often a particular warning message has been signaled.

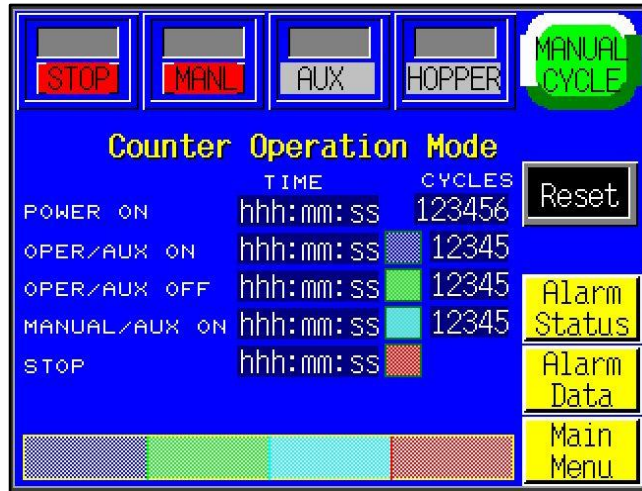

Figure 3-19

3.25 Machine Info

This screen provides information about the machine, such as the model number and the serial number. See Figure 3-21.

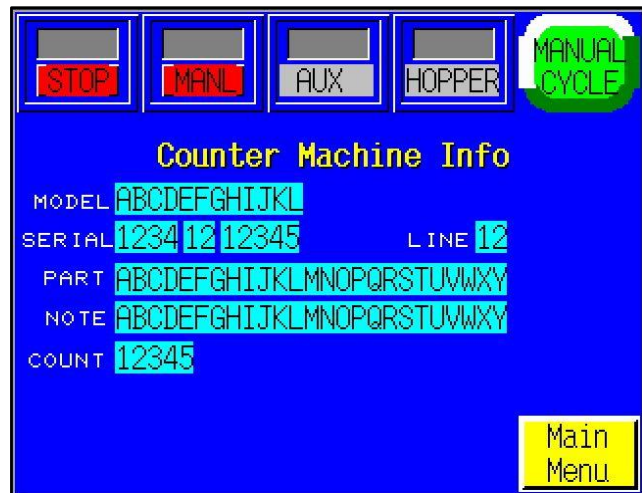

Figure 3-21

3.26 Information Screens

The Ultra-Count program provides for many informational screens that display descriptions of functions or screens. See Figures 3-22 through 3-26 for examples of messages that indicate the status of the counter. Some screens provide functional messages that describe errors or the status of equipment, and some provide instructions for operators to follow to bring the bagger back online.

To reset a message screen, clear the condition first (if required) and then touch the screen.



Figure 3-22



Figure 3-23

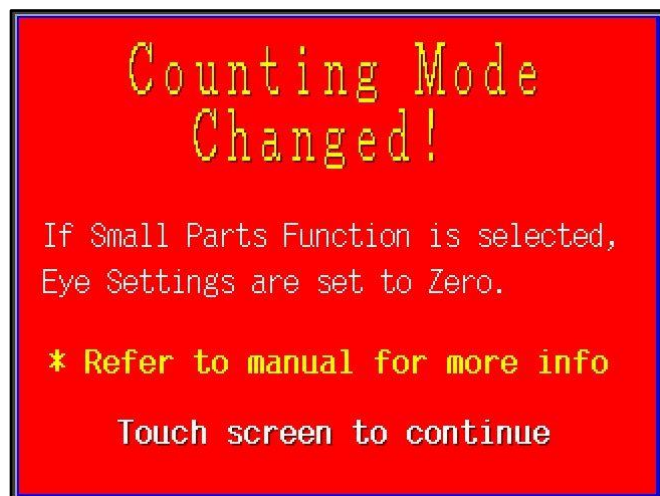

Figure 3-24



Figure 3-25

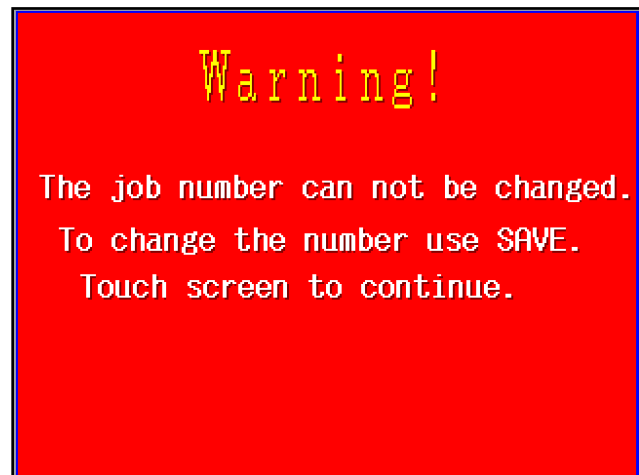

Figure 3-26

Chapter 4: Adjustments, Maintenance, Troubleshooting

Bowl Discharge Position

Skivers

Drop Gate

Level Switch

Bowl Drive

Erratic Bowl Feeding

Dead Spots

Coil Gap Adjustment

Spring “Tuning”

Belt Tracking

Accumulator Funnel Adjustment

Optical Frame Pot Settings

Height Adjustment

Troubleshooting Checklist

Troubleshooting: Base / Bowl Drive Unit

Troubleshooting Checklist (Conveyor Feed Problems)

PLC IO Listing

4.1 Bowl Discharge Position

Position the bowl so that it feeds onto the center of the belt drive and as close to the belt as possible. Loosen the bowl by loosening the bolts that hold the base drive to the bottom ring of the bowl and turn the bowl to the desired position. A clamp collar holds the V-track belt in position. Loosen the clamp collar to turn, raise or lower the V-track assembly.

NOTE: It may be necessary to adjust the feet on the bowl drive to accomplish proper bowl position. On some models, the V-track conveyor assembly can be positioned without moving the bowl for proper feeding of parts from the bowl to the conveyor.

4.2 Skivers

Adjust skivers so that parts flow in a consistent, steady, inline pace. Skivers are designed to orient the part to assist with parts separation. Use the skivers to brush off components stacked on top of other components. Use skivers to decrease the volume of parts on a track by pushing the product off the track and back into the bowl.

4.3 Drop Gate

The drop gate should be opened just far enough to allow a single part to pass over without dropping off. A second drop gate is provided to decrease the volume of parts to the final drop gate. Loosen the drop gate slide screws and push the gate in or out.

4.4 Level Switch

Vibratory bowls should be consistently fed with parts for best operation. Bowls that are full run slower than empty bowls, and inconsistent levels may cause incorrect counts. To maintain a consistent level of parts in the bowl, hoppers or a conveyor should be used to feed the bowl. A leveling switch is used to detect the level of parts in the bowl and to cause hoppers or a conveyor to turn on and feed parts into the bowl.

NOTE: Hoppers only feed when the bowl is in a fast feed mode.

Several types of level switches may be supplied, depending upon the bowl size and types of parts. If parts are not heavy enough to cause a leveling arm to move, then other types of sensors must be used, which include ultrasonic sensors or photo optic sensors.

Leveling Arm / Switch Adjustment: With a leveling arm, the switch should turn ON when the “paddle” portion of the arm is approximately ½" from the floor of the bowl and should remain ON from zero to ½". Adjust the arm by either resetting the position of the arm on the shaft or by turning an adjustment screw located on the side of the switch.

Some switches also have an LED that, when ON, indicates that the switch is ON. The LED should come ON when the paddle is approximately ½" above the surface of the bowl. Turn the adjustment screw counterclockwise to raise the paddle before the LED comes on. In other words, turn the screw counterclockwise to allow more parts to feed in the bowl before the hopper turns off.

If by turning the screw, the LED does not turn ON at a different paddle position, then the leveling arm must be repositioned. Loosen the screw that holds the shaft of the leveling arm in position and turn the shaft coming out of the sensor block until the LED remains ON when the paddle is touching the bowl up to ½" above the bowl. Retighten the screw.

Leveling Switch / Ultrasonic or Photo Optic: With a proximity sensor, proper parts level may be achieved by moving the sensor closer or further away from the bottom of the bowl. Some sensors have a “training” button that allows for electronic adjustment of the sensor to set the level of parts in the bowl.

NOTE: Overfilling the bowl will prevent the parts from moving smoothly or may cause the parts to stop flowing.

A green LED is located on a box to the rear of the hopper (or on the conveyor if a hopper conveyor system is supplied). The LED indicates that the hopper should be feeding. The hopper will only feed if the bowl is in fast feed mode. If the leveling switch turns ON and the bowl is in fast mode, the hopper will start to vibrate. The hopper will vibrate for at least five seconds even if the switch turned on for only a moment.

To increase the vibration level of the hopper, turn the potentiometer clockwise. To decrease the vibration level of the hopper, turn the potentiometer counterclockwise.

4.5 Bowl Drive

The drive has several adjustment points to allow for high production parts flow. However, do not advance the drive setting (fast or slow speed) to a higher feed rate than necessary as excessive vibration may decrease the useful output of the feeder. Do not mount external tracks or extensions to the feeder bowl without the manufacturer's approval. Such additions may create dead spots in the feeder bowl or may harm the power unit or decrease the feed rate. Additionally, maintain a gap between the feeder bowl discharge and the V-track so the bowl is not vibrating against components of the V-track or housing components.

4.6 Erratic Feeding of the Bowl

When erratic feeding is observed, ensure that the feeder bowl is securely mounted on the drive unit. All mounting screws must be tight. Check the bowl track to be sure there are no physical obstructions causing interruptions in the feed, such as parts stuck under wipers or parts wedged together and jammed between tracks. Check also to see if coatings on the parts, such as mold release compound, oil, dirt or some other foreign matter, may have made the track slippery or sticky, thus preventing the parts from properly driving up the track. A broken spring in any of the spring banks will cause the feed rate to diminish or stop. A broken spring screw will have the same effect. Removal and assembly of each spring bank, *one at a time*, will permit examination of springs. A cracked spring will make a dead sound when struck against a hard surface. A broken screw will be self-evident. All drive units are tuned before shipping. Tuning is accomplished by adding springs to the unit until a resonance is established between the driving coils and the mass being driven. A broken spring, or a broken or loose spring screw, destroys this resonance and the feeding ability diminishes or stops.

4.7 Dead Spots in the Bowl

Dead spots may occur in either the fabricated or cast bowls and are usually the result of an unequal distribution of mass in the bowl construction caused by tooling. They may also occur when one section of the bowl is not securely fastened to the drive unit, when a weld has broken or when part of the bowl track has loosened. This may be determined by removing the bowl from the drive unit and rotating it 90° from its original position. If the dead spot remains at the same point in the bowl, it can be assumed that the problem is in the bowl. Dead spots, caused by an unequal mass distribution in the bowl, are generally corrected by adding weight to a selected spot or spots on the outer periphery of the bowl, usually 180° from the dead spot.

4.8 Adjustment of the Coil Gap

The XL Series drive units are equipped with two adjustable coils mounted on the base casting and two fixed armatures mounted on the top plate. The air gap between each armature and coil is adjusted at the factory and under normal operation should not require any further adjustment. Should a continuous metallic rapping sound develop during feeder operation or when the power control knob is turned to maximum, it will indicate that the armature is striking the coil and damage to the feeder unit will occur if not corrected. To adjust the coil for a larger air gap, first back off the two ½" socket head cap screws

whose centers form a vertical line in the four screw pattern, an approximately 1/8" turn. Then tighten the two 1/2" socket head cap screws whose centers form a horizontal line in the four screw pattern, an approximately 1/8" turn. This will draw the coil back away from the armature about an additional 0.009" and should eliminate the metallic rapping sound. Care should be taken to loosen both of the vertical screws the same amount and tighten the two horizontal screws the same amount so that the surface of the coil remains parallel to the surface of the armature. Normal air gaps run from 0.025" to 0.040". Some units could have as little as a 0.015" gap or as much as a 0.075" gap. To adjust the coil for less air gap, back off the two horizontal screws and tighten the two vertical screws, the same amount each. Make sure all four screws are tight after making the adjustment.

4.9 Spring "Tuning"

The XL Series drive units employ four spring banks for tuning the drive unit. These spring banks usually contain the same number and thickness of springs; however, sometimes due to bowl construction or bowl tooling, it is necessary to vary the number and thickness of the springs in each bank. When springs of different thickness are used in a spring bank, the thickest spring should always be placed so that it is next to the base and top plate castings and the thinner springs toward the screw heads. A smaller diameter and lighter weight bowl will require less or thinner springs than a larger diameter and heavier bowl.

The XL Series drive units are powered by alternating 60-cycle current, which energizes the coil at a rate of 120 pulses per second. These pulses cause the coils to magnetize and draw the armature toward them, thereby flexing the springs. The combined spring force must be sufficient to return the armatures to their original or neutral position at the same rate of 120 reactions per second. When this happens, the unit is properly tuned for 60 cycle current. If the power source is 50 cycle, as used in some European countries, the drive unit must be re-tuned by reducing the number or thickness of springs. If the power source is other than 110/120 Volt, then different coils must be used (240 volt AC coils are available from stock).

4.10 Belt Tracking

The V-track belt is constructed of two small conveyors at 90 degrees to each other. Each belt has a drive roller and a tracking roller. The tracking roller is located at the discharge end of the belt where all adjustment points are located.

To adjust the belt tracking, first remove the accumulator/eye assembly. Bolts holding the accumulator to the V-track assembly are located beneath the belt, to the rear of the accumulating funnel.

With the accumulator removed, the adjustment screw and slot can be seen to adjust the position / alignment of the rollers.

Adjust the roller up or down to correct the belt alignment. When properly adjusted there should be a very small (1/16") gap between the belts as they are running.

4.11 Accumulator Funnel Adjustment

The accumulator funnel mounts to the V-track conveyor assembly. The optical frame slides into the accumulator funnel. The optical frame must be positioned at the end of the V-track so that parts discharging from the belt completely pass through the photo array. If parts only partially pass through the eye (beneath the eye), miscounts can occur. Larger / longer parts may require the optical frame to be positioned further away from the end of the conveyor to avoid parts blocking the photo array when hanging from a stopped belt. To adjust the accumulator funnel, loosen the bolts positioned beneath and to the rear of the accumulator.

4.12 Optical Frame Pot Settings

The optical frame (four sided frame) has four potentiometers that control the functionality of the outputs to the PLC. Factory settings provide for a static output (output is ON while the detection area is blocked or parts are present). Additionally, the sensitivity is set to the highest possible setting.

Factory settings are described while holding the frame so that you are looking at the pots with the cable extending out from the eye, to the LEFT of the pots.

You will see that there are four pots with covers over the two center pots. Remove these covers to change settings.

POT 1 (left most pot): OUTPUT DURATION: Set at the factory to the most CCW position. This pot is used only when the optical frame is set to Dynamic functionality. Since the optical frame is set at the factory to Static (not Dynamic), you only need to adjust this pot if you have changed POT 2 to the Dynamic position. Again, POT 2 is set at the factory to the most CCW position. If you do reset POT 2 to Dynamic, use a small flat head screw driver and turn the pot clockwise to increase the output duration.

POT 2 (second from the left): STATIC / DYNAMIC: Set at the factory to STATIC, the most CW position. Static functionality means that when the eye is blocked, the output is ON. To test the eye, you can place your finger in the eye field and you will notice that the LED at the base of the cable is ON continually while the eye is blocked. To change to the DYNAMIC functionality, turn the pot using a small flathead screwdriver to the most CCW position. Dynamic functionality means that the output to the PLC will be a fixed time, regardless of the length of the part. If you change to the DYNAMIC functionality, you may need to change the output duration (POT1) to achieve the correct counting function. Be careful not to set the duration too long or two parts may be passing through the optical frame while only one output is given to the PLC.

POT3 (third from the left): DARK/LIGHT mode: Set at factory to DARK, the most CCW position. Do not reset this POT or the output to the PLC will not be in the proper sequence.

POT4 (right most pot): SENSITIVITY adjustment: Set at the factory to the most sensitive position, which is the most CW position. The eye is set to the most sensitive setting so that even the smallest parts can be detected in the field. To cause the detection to be less sensitive (to not see scrap, for instance), turn the pot CCW until the scrap is not detected (may not work properly for parts that are too large).

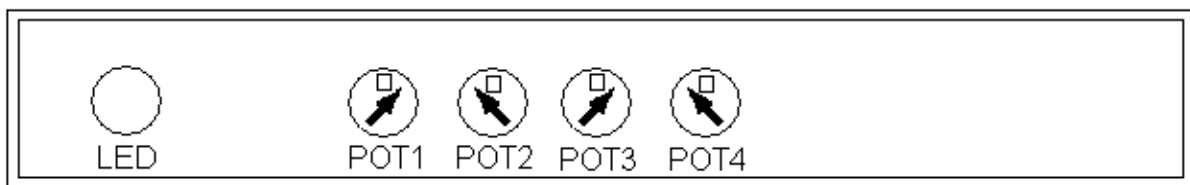

NOTE: Illustration of factory settings/pots.

4.13 Height Adjustment

The UC-2400, when sold individually, mounts to a single column telescoping stand. The height can be adjusted, but due to the weight of the unit, a lift truck or other similar device must be used. Position the forks of the lift truck beneath the mounting plate of the bowl. Slightly lift the forks and tilt back the forks so that the weight is off the stand and so that if the unit slides, it will slide toward the lift truck. Loosen the screws from the side with two others holding the unit in position. Raise or lower the unit with the lift truck and tighten the screws. The UC-3000 mounts to a double column telescoping stand but still requires the same adjustment procedure as the UC-2400.

CAUTION: Extreme safety must be used due to the weight of the unit to avoid severe injury. Only trained and licensed lift truck operators should perform these tasks.

4.14 Troubleshooting Checklist for Ultra-Count Systems

PROBLEM	POSSIBLE CAUSE	CORRECTIVE ACTION
Touch screen does not display	<ol style="list-style-type: none"> 1. Power off 2. Main fuse blown 3. Breaker tripped 4. IOP cables loose/damaged 5. Contrast out of adjustment 	<ol style="list-style-type: none"> 1. Check main/individual power switch; Plug in power cord 2. Replace fuse #1 on the module 3. Check breaker in main power box. 4. Check cables behind IOP cover 5. Adjust screen contrast
No main power LED	<ol style="list-style-type: none"> 1. Power off 2. Main fuse blown 3. Breaker tripped 4. IOP cables loose/damaged 5. LED burned out 	<ol style="list-style-type: none"> 1. Check main/individual power switch; Plug in power cord 2. Replace fuse #1 on the module 3. Check breaker in main power box 4. Check cables behind IOP cover 5. Replacement not possible
No run LED	<ol style="list-style-type: none"> 1. IOP in program mode 2. LED burned out 	<ol style="list-style-type: none"> 1. Press “System” key then “F1” key 2. Replacement not possible
Accumulating funnel not functioning correctly or not at all	<ol style="list-style-type: none"> 1. No/low air pressure 2. Leaking hoses or air cylinders 3. Accumulator in “open” mode 4. “Batch toggle switch” is “off” 5. <i>Belt drive</i> cable loose/damaged 	<ol style="list-style-type: none"> 1. Check main and individual regulators; Check for kinked air hoses 2. Check all air hoses and cylinders 3. Check mode on “Operation Screen” 4. Check switch on “Operation Screen” 5. Check <i>belt drive</i> cable
Part sensor (eye) not functioning	<ol style="list-style-type: none"> 1. Part dust in eye 2. Eye cables loose/damaged 	<ol style="list-style-type: none"> 1. Wipe inside of eye 2. Check eye cables
Bowl not driving well or not at all	<ol style="list-style-type: none"> 1. Bowl overfilled 2. “Bowl Fast” and/or “Bowl Slow” values set too low 3. Bowl drive cable loose/damaged 	<ol style="list-style-type: none"> 1. Empty bowl 2. Check values on “Settings Screen” 3. Check bowl drive cable
Hopper does not run	<ol style="list-style-type: none"> 1. “Hopper toggle switch” is “off” 2. Counter running in “Bowl Slow” mode 3. Part level in bowl too high 4. Hopper cable loose/damaged 5. Level sensor cable loose/damaged 6. Hopper fuse blown 	<ol style="list-style-type: none"> 1. Check switch on “Operation Screen” 2. Check the “Slow indicator” on “Operation Screen”- adjust “Slow Count” on “Counter Settings Screen” 3. Move parts so level arm can touch the bottom of the bowl 4. Check hopper cable 5. Check level sensor cable 6. Replace fuse #2 on the module
Bowl overfills	<ol style="list-style-type: none"> 1. Gate on hopper raised too high 2. Ramp on front of hopper sloped down too far 3. Hopper running after bowl is full 4. Level sensor cable damaged 	<ol style="list-style-type: none"> 1. Lower gate 2. Raise ramp 3. Adjust part level sensor 4. Check level sensor cable
Belt does not move	<ol style="list-style-type: none"> 1. Part(s) jamming belt 2. “Belt Speed” set too low 3. Belt drive cable loose/damaged 	<ol style="list-style-type: none"> 1. Check belt housing for loose parts 2. Check “Belt Speed” value on “Counter Settings Screen” 3. Check belt drive cable

4.15 Troubleshooting: Base / Bowl Drive Unit

Should your bowl stop completely (i.e., no vibration or humming sound at all), the reason will be an *electrical* failure. Carefully check the following to be certain that:

1. The power cord is plugged into a live outlet. For troubleshooting purposes, unplug the power during remaining electrical checks.
2. The fuse on the controller is good.
3. The auxiliary contacts inside the controller are properly shorted or jumpered together.
4. The input and output power connections inside the controller are good and sound.
5. The coil wires are properly connected to the controller output wires.
6. The coils themselves show continuity with the controller disconnected. If there is still no output, then the controller should be returned to the factory. If the failure is not our responsibility, APPI will advise you of repair costs.

If your bowl feeder does not stop feeding completely, or starts feeding slowly or erratically (i.e., fast then slow), and you can hear the unit humming, then the problem is *mechanical*. Carefully check the following to be certain that:

1. Parts are not jammed under track wipers or wedged between tracks.
2. The feeder bowl mounting screws are tight.
3. The rubber mounting feet are not cut and are securely tightened to the feeder base.
4. The rubber mounting feet are not tight in the foot locators (if used).
5. The armatures and coils have an air gap between them.
6. There is no loose tooling in the feeder bowl.
7. Parts are not slipping or sticking on the track due to oily air contamination, mold release compound from parts, etc.
8. There are no broken welds, especially track welds, on the fabricated bowls. A broken track weld could cause a dead spot, erratic feeding or a metallic rattle.
9. Other equipment is not restricting the bowl from vibrating freely.
10. There are no cracked or broken springs in any of the spring banks.
11. There are no broken spring mounting screws.

If, after checking all of the above, the feeder still does not feed properly, then get a 13/16" box wrench and check both the upper and the lower spring mounting screws for tightness. If the screws seem excessively tight, try loosening each set of four screws about 1/8" of a turn each. (The amplitude control knob should be set at the maximum feed position while doing this.)

If the screws are loose, the feed rate will slow down to a point where feeding will stop entirely. Progressively tighten the four upper spring screws, and then tighten the four lower screws.

As you tighten the screws, the feed rate should immediately pick up. You will know by the sound of the feeder when you have attained the proper torque on the screws. Attempt to tighten all screws to the same torque.

4.16 Troubleshooting Checklist (Conveyor Feed Problems)

PROBLEM	POSSIBLE CAUSE	CORRECTIVE ACTION
Conveyor feeds more than once	<ol style="list-style-type: none"> 1. Conveyor is in “continuous” mode instead of “auto” 2. Conveyor’s part sensors are dirty or out of alignment 3. Cleat sensor under the conveyor is dirty, has been moved or needs adjusted 4. Cable connecting the counters, conveyor, bagger loose/damaged 5. Cleat sensor cable damaged 6. Part sensor cables loose/damaged 	<ol style="list-style-type: none"> 1. Change mode on the conveyor control panel 2. Wipe the part sensors/check that the eyes are in line 3. Wipe sensor, tilt sensor bracket, turn sensitivity adjustment 4. Check the cables connecting the counters, conveyor and bagger 5. Check cleat sensor cable 6. Check conveyor’s part sensor cables
Conveyor does not feed	<ol style="list-style-type: none"> 1. Conveyor is unplugged 2. Conveyor switch on back of panel is off 3. Main power switch is off 4. Cable connecting the counters, conveyor, bagger loose/damaged 5. Conveyor motor breaker tripped 6. Damaged conveyor motor relay 7. Conveyor not in “run” mode 8. Bagger not ready 9. A counter has auxiliary “on” and is not in “run” mode 10. Parts jam at an individual counter 11. Counter eye problem 	<ol style="list-style-type: none"> 1. Plug in conveyor 2. Switch conveyor on 3. Throw main power switch 4. Check the cables connecting the counters, conveyor and bagger 5. Check main power box for tripped breaker 6. Check main power box for bad relay 7. Change mode on the conveyor control panel 8. Confirm bagger is in auto mode, is not paused, has a properly threaded supply of bags, has a supply of heat transfer film, etc. 9. Check all counters. Auxiliary should be “on” if counter is being run. 10. Check all counters for “Part Flow Interruption Screen” 11. Check for a counter that cannot “see” parts - wipe the inside of the eye

4.17 PLC IO Listing

The Main PLC IO (Inputs and Outputs) Listing is provided to assist in troubleshooting the UC-2400.

MAIN PLC				
	Input	Description	Output	Description
	X0	Parts Count	Y0	Spare
	X1	Reserved	Y1	Spare
	X2	Reserved	Y2	Aux Out
	X3	Aux In	Y3	Hopper Drive
	X4	Level Sensor	Y4	Bowl Drive
	X5	Spare	Y5	Accum Sol
	X6	Spare	Y6	Aux In Reflc
	X7	Spare	Y7	Belt Drive
	X8	Spare	Y8	Spare
	X9	Spare	Y9	Spare
	XA	Spare	YA	Spare
	XB	Spare	YB	Spare
	XC	Spare	YC	Spare
	XD	Spare	YD	Spare
	XE	ESTOP	YE	Spare
	XF	Spare	YF	Spare

Chapter 5: Parts and Drawings

Ultra-Count 2400

Electronics Assembly

Cable Assemblies

V-Track Assembly, Long

Touch Screen Assembly

Accumulator Funnel Assembly

Optical Eye Assembly

Supply Hopper Assembly

24" CCW Vibratory Bowl

Prox Sensor Assembly

Ultra-Count Stand

Ultra-Count 3000

Stand Assembly

Supply Hopper

30" CCW Vibratory Bowl

Electrical Drawings

5.1 Ultra-Count 2400

T-UC2400

ITEM NO.	QTY	PART NO.	DESCRIPTION	SECTION NO.	PAGE NO.
1	1	TA-UC1000-DC	ELECTRONICS ASSEMBLY	5.1	41
2	1	TA-UC2000-DC	CABLE ASSEMBLIES	5.2	43
3	1	TA-UC2400-LDC	V-TRACK ASSEMBLY, LONG	5.3	45
4	1	TA-UC3000	TOUCH SCREEN ASSEMBLY	5.4	53
5	1	TA-UC5000	ACCUMULATOR FUNNEL ASSEMBLY	5.5	57
6	1	TA-UC5560	OPTICAL EYE ASSEMBLY	5.6	59
7	1	TA-UC6500	SUPPLY HOPPER ASSEMBLY	5.7	61
8	1	TA-UC7000	CCW VIBRATORY BOWL ASSEMBLY	5.8	63
9	1	TA-UC8000	PROX SENSOR ASSEMBLY	5.9	65
10	1	TA-UCSTAND	ULTRA-COUNT STAND	5.10	67

*NOTE 1: If you purchased the UC-2400 with the **Short V-Track configuration**, your part numbers are the same as those listed above, with the following exception: Item 3 is replaced with TA-UC2400-SDC.*

*NOTE 2: If you purchased the UC-2400 with the **Clockwise Bowl configuration**, your part numbers are the same as those listed above, with the following exception: Item 8 is replaced with TA-UC7000-1.*

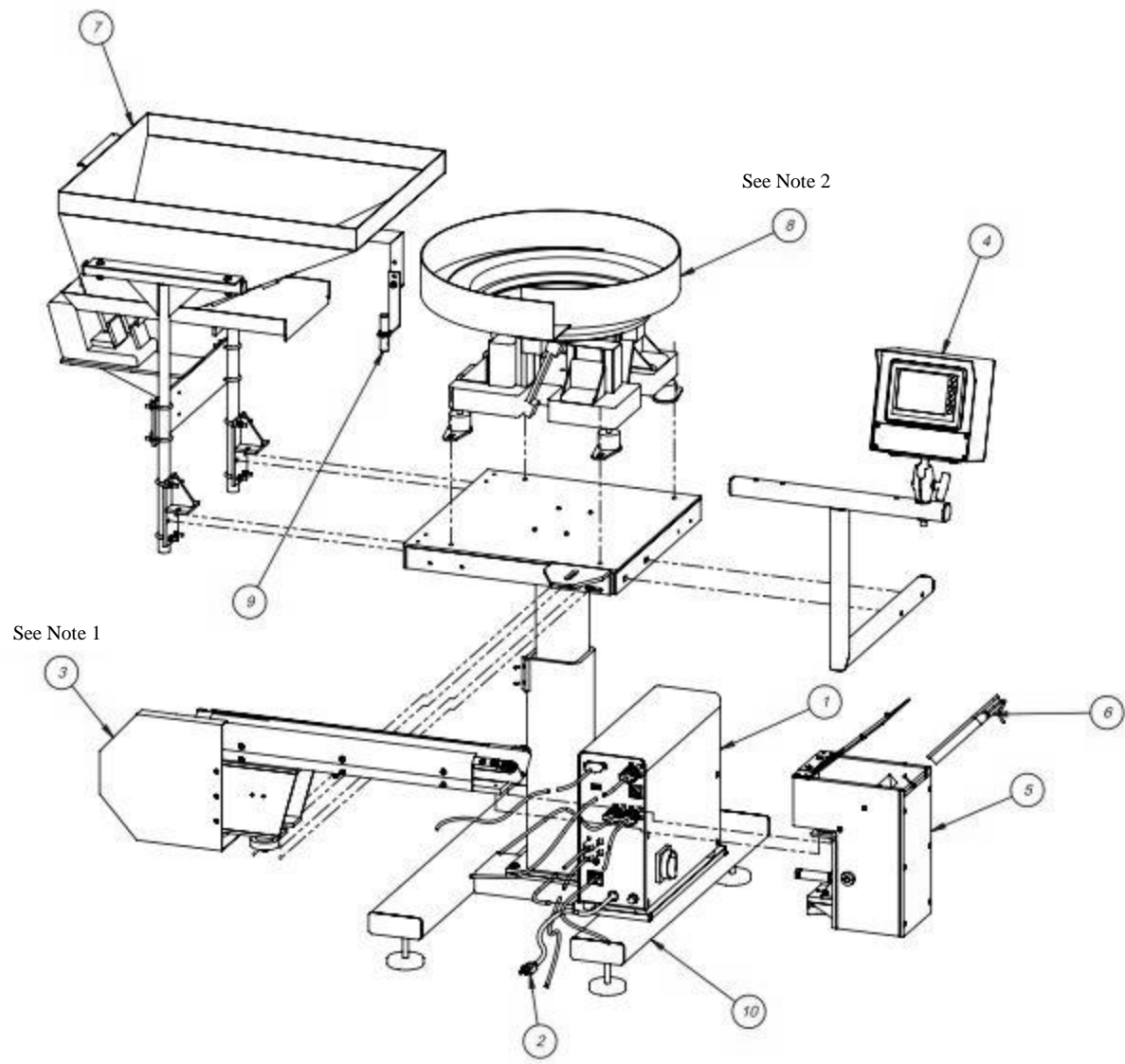

Standard UC-2400 Model

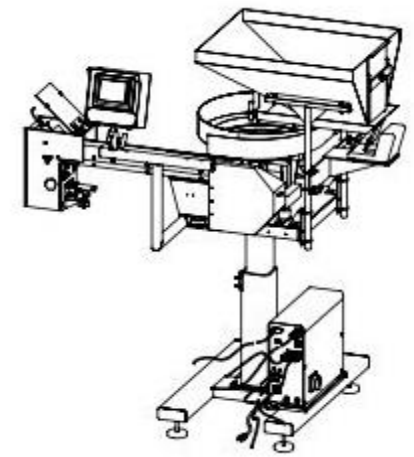

Optional Clockwise Bowl Model

5.2 Electronics Assembly

PN: TA-UC1000-DC

ITEM NO.	QTY.	PartNo	DESCRIPTION
1	1	TP-MM1-0001	ELECTRONICS BACK PANEL
2	1	TP-MM1-0002	ELECTRONICS PANEL
3	1	TP-MM1-0003	BACK COVER
4	1	TP-MM1-0004	FRONT COVER
5	2	TP-MM1-0005	STAND-OFF
6	1	TP-205108	EMI FILTER, CORCOM
7	2	TP-224001	PCB, SUPPLY HOPPER CONTROLLER
8	2	TP-112240	POWER CORD STRAIN RELIEF
9	1	TP-212410	AC OUTLET
10	1	TP-212248	CONNECTOR, MULTIPOLE RECTANGULAR
11	1	TP-207216 , TP-207344	FUSE HOLDER & FUSE
12	1	TP-212160	5 POS MINI DIM
13	3	TP-212247	CONNECTOR, MULTIPOLE RECTANGULAR
14	1	TP-212167	6 PIN FEMALE
15	1	TP-TP-212229	7 PIN AMPHENOL MALE
16	2	TP-212333	3 PIN FEMALE AMPHENOL
17	1	TP-215005	SWITCH
18	1	TP-215004	SWITCH KNOB
19	4	TP-110766	1 INCH DIA. RUBBER FOOT - 1/4-20 x .375 STUD
20	1	TP-T10MM1006	OVERLAY FOR UC-2400
21	1	TP-220515	PLC ANALOG
22	1	TP-213426(US), 213427(NON- US)	24 VOLT POWER SUPPLY
23	1	TP- 220511	PLC, FPG-C32T2H GREY
24	2	TP-501173-3	DC MOTOR DRIVE
25	4	TP-214275	3/4" LONG 6-32 STANDOFF
26	2	TP-218021	DIN RAIL
27	4	TP- 214285	STAND-OFF 1-1/2" LONG 6-32
28	6	TP-208141	SMALL TERMINAL BLOCK
29	13	TP- 208142	LARGE TERMINAL BLOCK
30	1	TP-218020	DIN RAIL
31	1	TP-215116	RELAY SOCKET
32	1	TP-215115	AUX RELAY

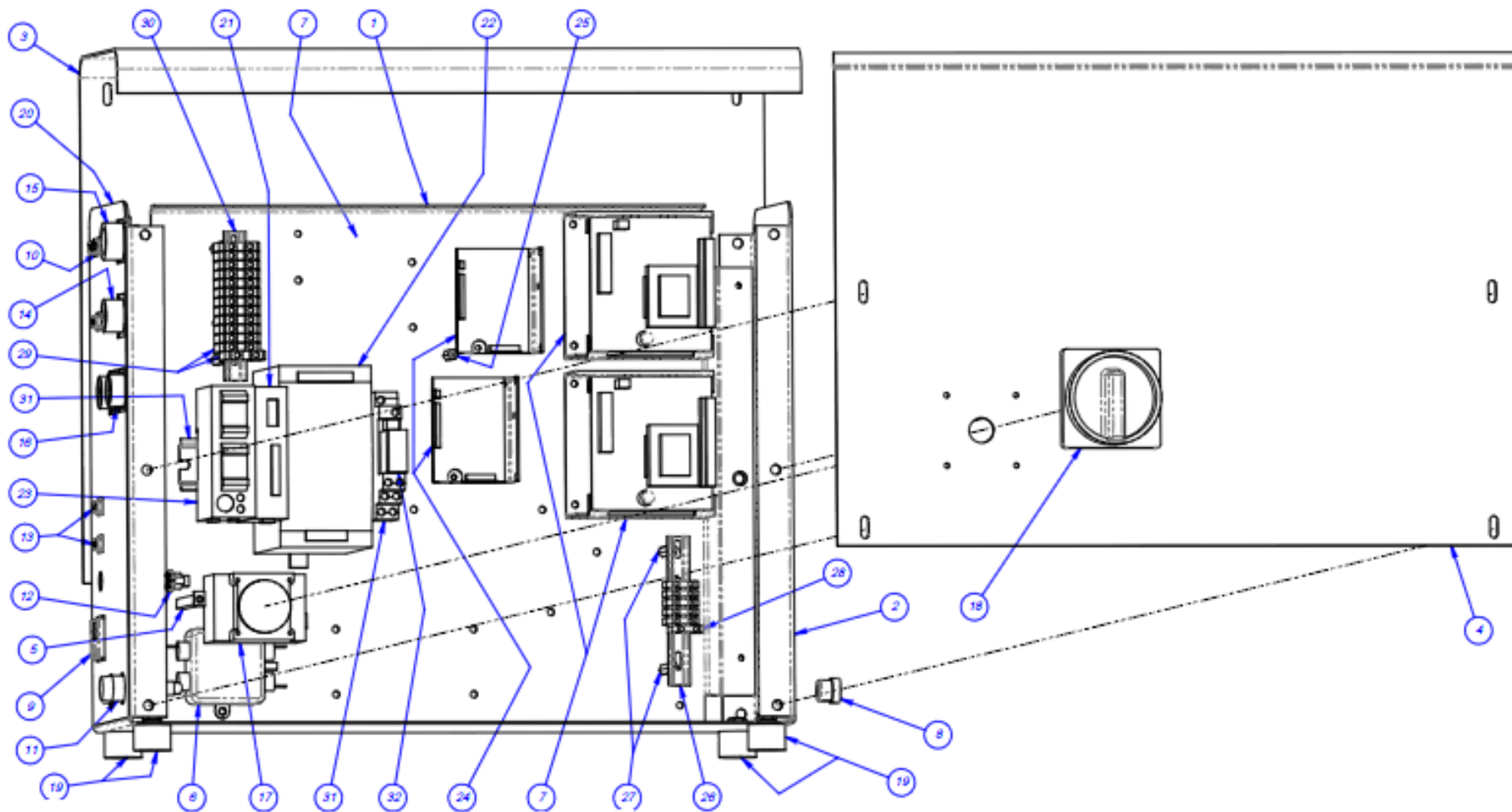

5.3 Cable Assemblies

PN: TA-UC2000-DC

ITEM NO.	QTY	PART NO.	DESCRIPTION
1	1	TA-UC2020	POWER CABLE
2	1	TA-UC2011	EYE CABLE
3	1	TA-UC2030	AUX IN / OUT CABLE
4	1	TA-UC2040	HOPPER CABLE
5	1	TA-UC2061	DC DRIVE V-TRACK CABLE
6	1	TA-UC2070	BOWL DRIVE CABLE

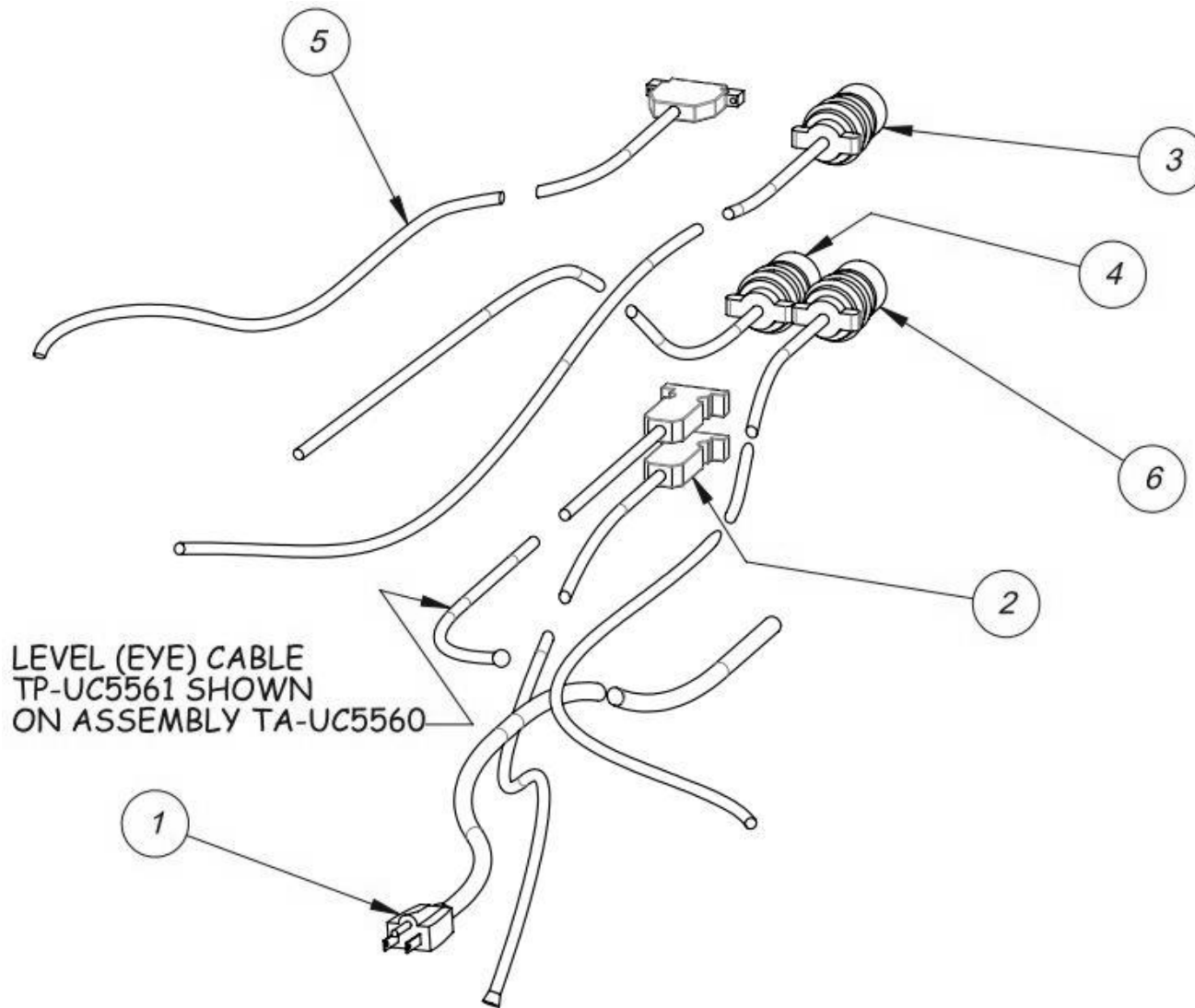

5.4 V-Track Assembly, Long

PN: TA-UC2400-LDC

ITEM NO.	QTY	PART NO.	DESCRIPTION
1	1	TA-UC2400-LDC1	LONG BELT GUIDE ASSEMBLY
2	1	TA-UC2400-DC2	BELT DRIVE HOUSING ASSEMBLY
3	1	TP-T10MA8022	CCW CASE
4	1	TP-503103	CONVEYOR BELT
5	1	TP-503104	CONVEYOR BELT

*NOTE: If you purchased the UC-2400 or UC-30000 with the **Short V-Track configuration**, your part numbers for the V-track assembly are the same as those listed above, with the following exceptions: Item 1 is replaced with TA-UC2400-SDC1, Item 4 is replaced with TP-503105, and Item 5 is replaced with TP-503106.*

*NOTE: If you purchased the UC-2400 with the **Clockwise Bowl configuration**, your part numbers for the V-track assembly are the same as those listed above, with the following exception: Item 3 is replaced with TP-T10MA8033.*

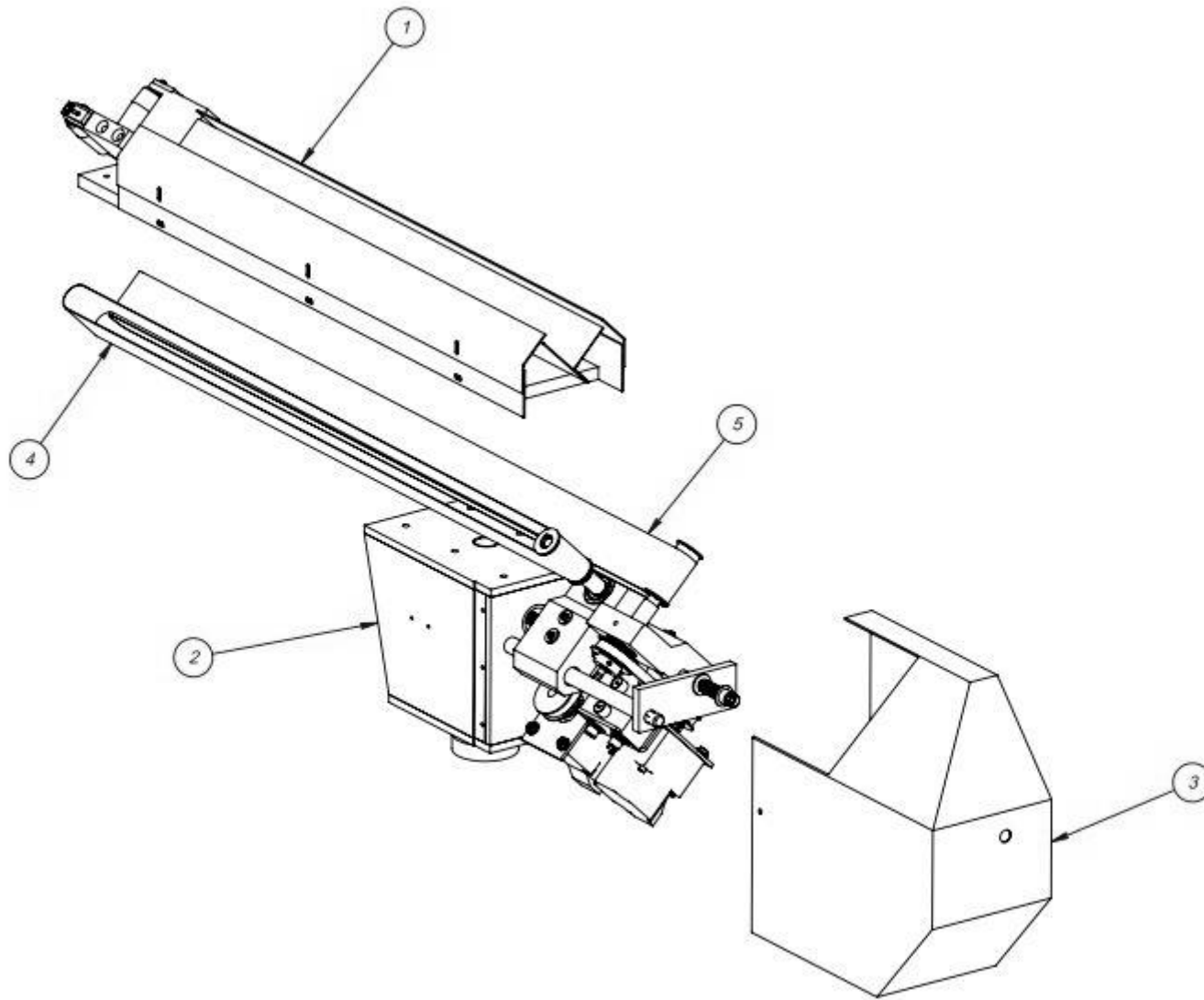

V-TRACK ASSEMBLY, LONG
PN: TA-UC2400-LDC

Long Belt Guide Assembly

PN: TA-UC2400-LDC1

ITEM NO.	QTY	PART NO.	DESCRIPTION
1	1	TP-T10MA8011	CONVEYOR PLATE
2	1	TP-T10MA8012LH	ROLLER BLOCK
3	1	TP-T10MA8012RH	ROLLER BLOCK
4	2	TP-T10MA8013	IDLER ROLLER
5	1	TP-T10MA8014	ANGLE MOUNT
6	2	TP-T10MA8015	ADJUSTER
7	2	TP-T10MA8016	ROLLER SHAFT
8	1	TP-T10MA8017LH	LOWER GUARD
9	1	TP-T10MA8017RH	LOWER GUARD
10	1	TP-T10MA8018LH	UPPER GUARD
11	1	TP-T10MA8018RH	UPPER GUARD
12	1	TP-T10MA8023	BELT SUPPORT ANGLE
13	1	TP-T10MA8024	BELT SUPPORT FLAT
14	2	TP-T10MA8025	BELT SUPPORT BLOCK
15	2	TP-108095	RETAINING RING E-STYLE

*NOTE: If you purchased the UC-2400 or UC-3000 with the **Short V-Track configuration**, your part numbers for the Belt Guide Assembly are the same as those listed above, with the following exceptions: Item 1 is replaced with TP-T10MA8011-S, Item 8 is replaced with TP-T10MA8017LHS, Item 9 is replaced with TP-T10MA8017RHS, Item 10 is replaced with TP-T10MA8018LHS, Item 11 is replaced with TP-T10MA8018RHS, Item 12 is replaced with TP-T10MA8023-S, and Item 13 is replaced with TP-T10MA8024-S.*

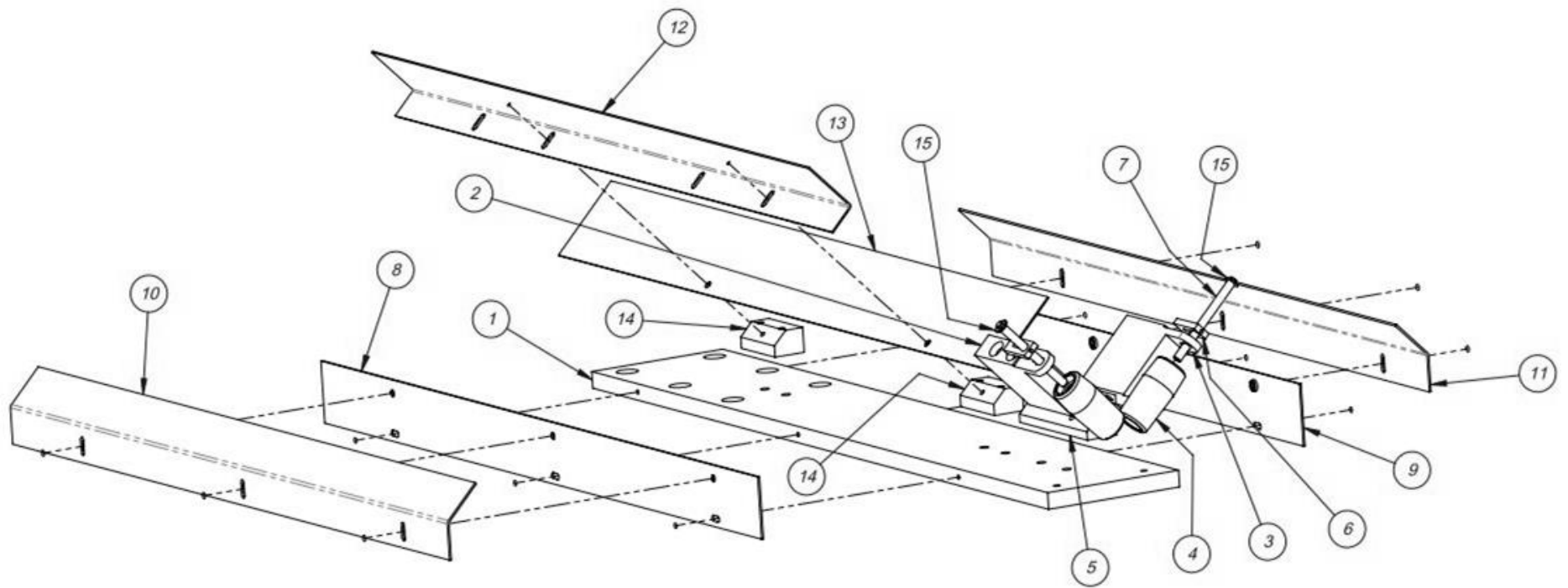

LONG BELT GUIDE ASSEMBLY
PN: TA-UC2400-LDC1

Belt Drive Housing Assembly

PN: TA-UC2400-DC2

ITEM NO.	QTY	PART NO.	DESCRIPTION
1	2	TA-UC2400-DC3	BELT DRIVE ASSEMBLY
2	1	TP-T10MA8007	FRAME BLOCK
3	1	TP-T10MA8008	TIE PLATE
4	2	TP-T10MA8009	TIE ROD
5	1	TP-T10MA8010	SPRING CUP
6	1	TP-T10MA8019	VERTICAL SUPPORT ROD
7	1	TP-T10MA8020	SUPPORT COLUMN
8	1	TP-402175	BRACKET
9	1	TP-402255	VALVE
10	1	TP-401277	ELBOW, 1/4" TUBE x #10-32
11	2	TP-404263	MUFFLER
12	3	TP-102144	3/8 FLAT WASHER
13	2	TP-108124	COMPRESSION SPRING
14	1	TP-103547-3	SCREW, SET 3/8-16 x1
15	1	TP-103254	SCREW, SHCS 3/8-16 x3-1/2

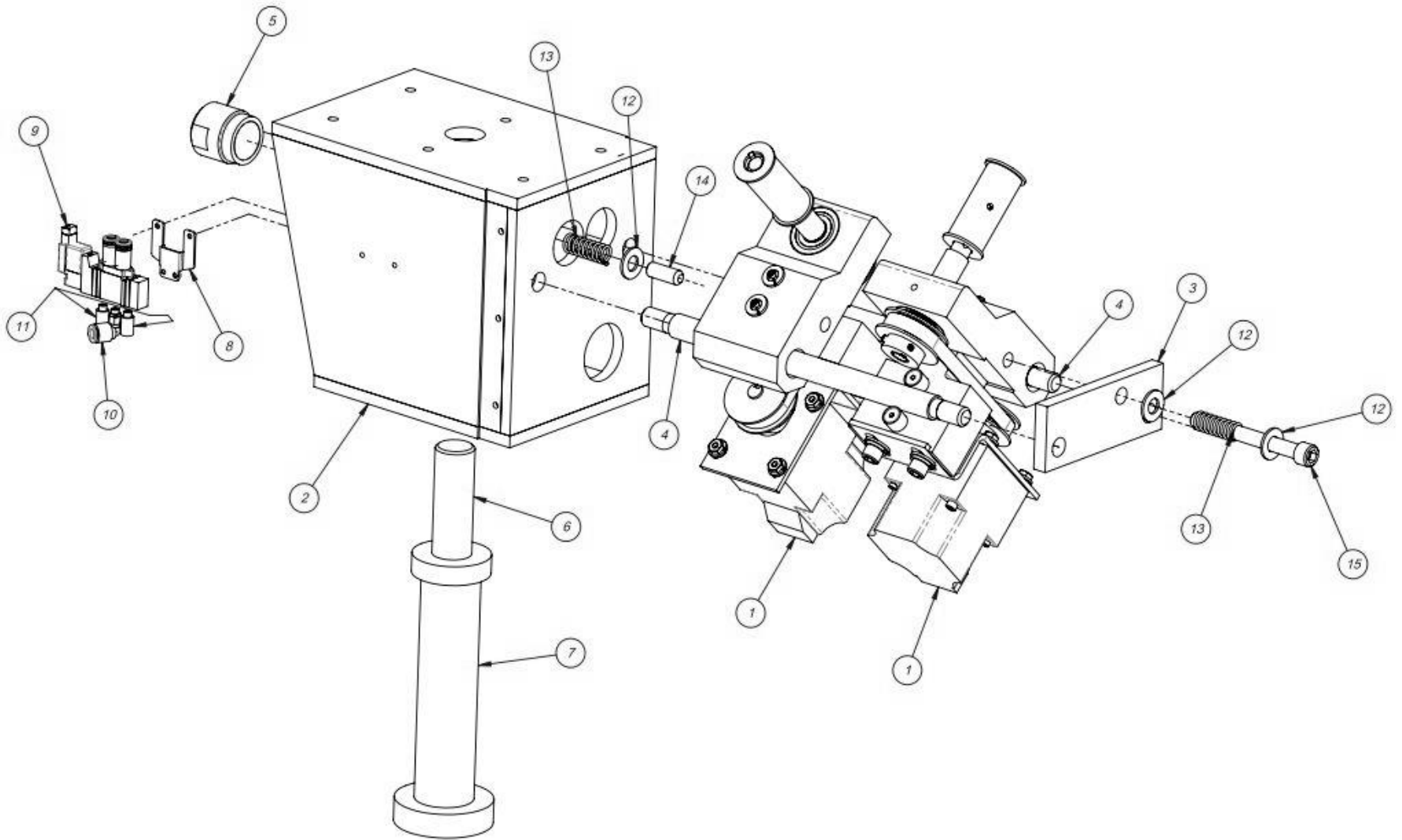

BELT DRIVE HOUSING ASSEMBLY
PN: TA-UC2400-DC2

Belt Drive Assembly

PN: TA-UC2400-DC3

ITEM NO.	QTY	PART NO.	DESCRIPTION
1	1	TP-T10MA8002	SLIDE BLOCK
2	1	TP-T10MA8003	STAND-OFF
3	1	TP-T10MA8004	MOTOR BRACKET
4	1	TP-T10MA8005-1	DRIVEN ROLLER SHAFT
5	1	TP-T10MA8006	DRIVEN ROLLER
6	1	TP-T10MA8026	BELT DRIVE PULLEY
7	1	TP-T10MA8031DC	MOTOR PULLEY
8	2	TP-504115	BALL BEARING
9	1	TP-107343	THRUST BEARING
10	2	TP-504133	CAM FOLLOWER
11	3	TP-308398	0.125 SQ. KEYSTOCK
12	1	TP-501173	DC MOTOR
13	1	TP-503102	DRIVE BELT

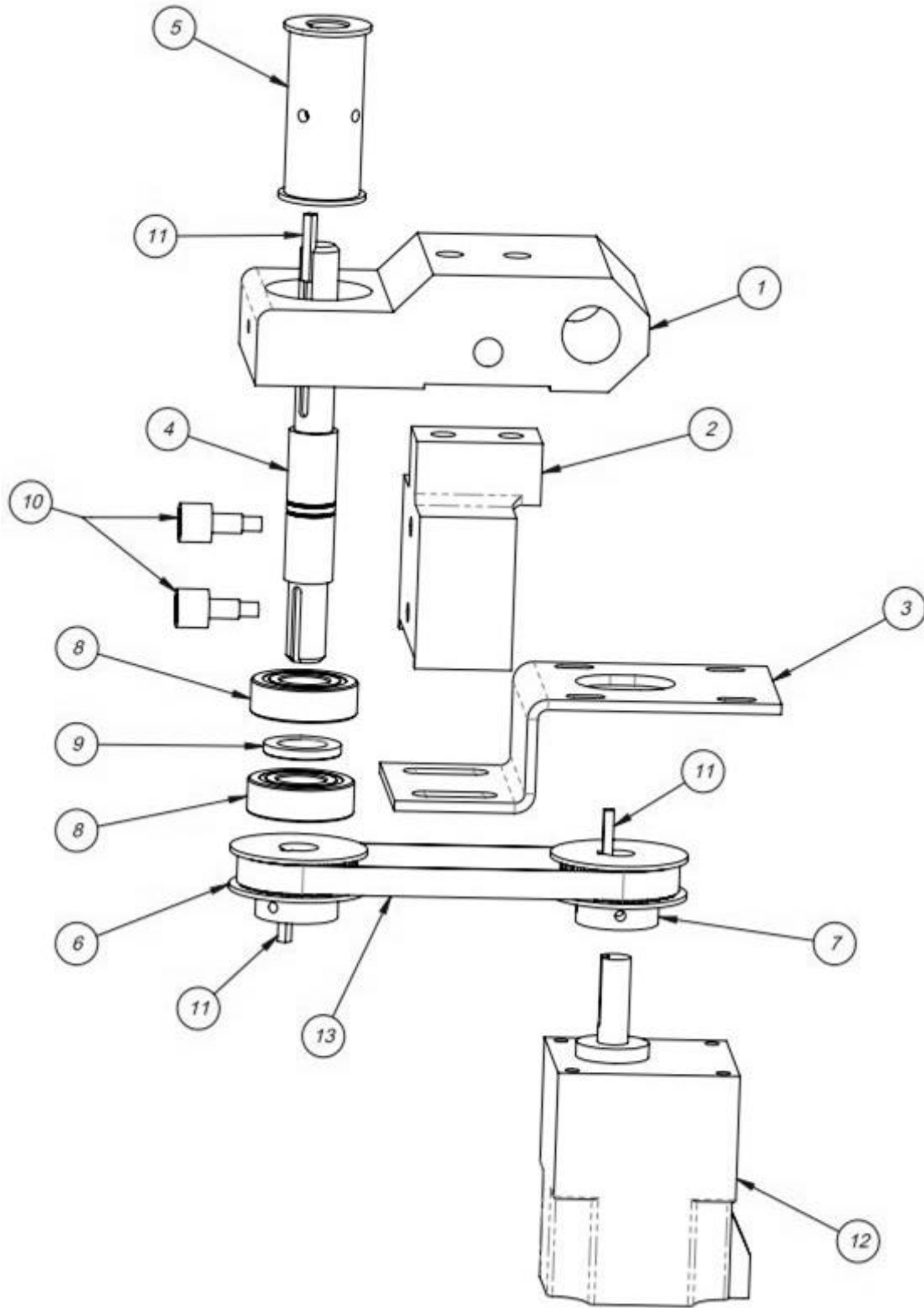

5.5 Touch Screen Assembly

PN: TA-UC3000

ITEM NO.	QTY.	PartNo	DESCRIPTION
1	1	TP-T10MA0214	IOP FRAME
2	2	TA-T10240-IOP	SEVEN INCH TOUCH SCREEN
3	2	TP-103070	Screw, SHCS 3/8-16 x 2-1/4
4	2	TP-102144	Washer, 3/8 FLAT
5	2	TP-102157	Washer, 3/8 LOCK
6	2	TP-101114	Nut, 3/8-16 HEX

NOTE: The UC-2400 / UC-3000 can be equipped with either one touch screen or with two touch screens. The quantities listed above apply to the two touch screen model. If your UC-2400 / UC-3000 only has one touch screen, halve the above quantities, except for Item 1, the IOP frame.

NOTE: For multiple Ultra-Count Systems, each module may have its own mounting bracket.

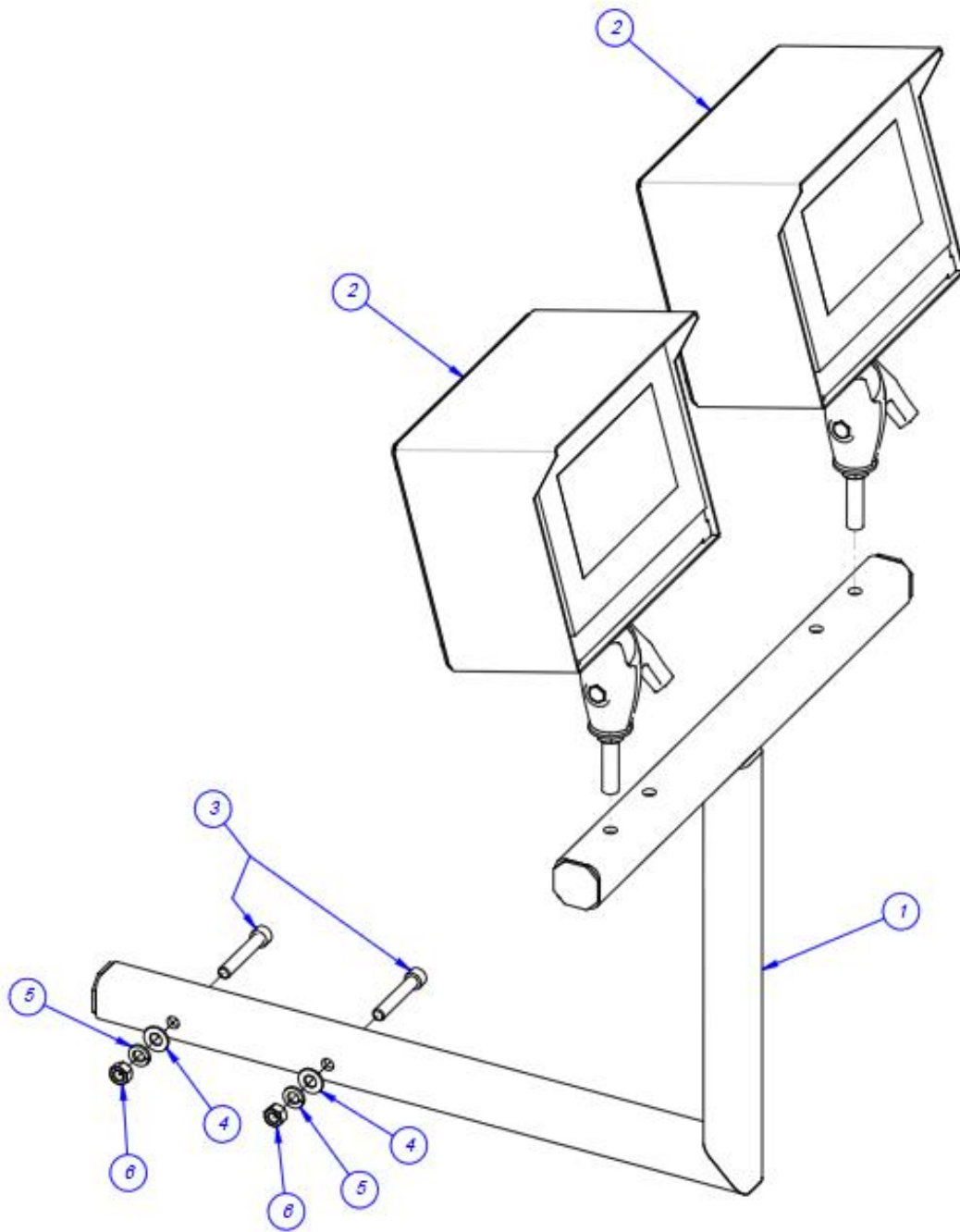

5.5a Touch Screen Subassembly

PN: TA-T10240

ITEM NO.	QTY.	PartNo	DESCRIPTION
1	1	TP-T1MD00040	TOUCH SCREEN HOUSING
2	1	TP-T1MD00040-1	BACK COVER
3	1	TP-111131	BALL GRIP POSITIONING ARM
4	1	TP-111125-2	SOCKET ARM
5	4	PART OF TP-220363	SCREEN STUD
6	4	PART OF TP-220363	SCREEN CLIP
7	1	TP-220364	TOUCH SCREEN
8	1	TP-IOPBOLT-L	MODIFIED BOLT
9	1	TP-102147	Washer, 5/8 FLAT
10	1	TP-101125	Nut, 1/2-13 HEX JAM

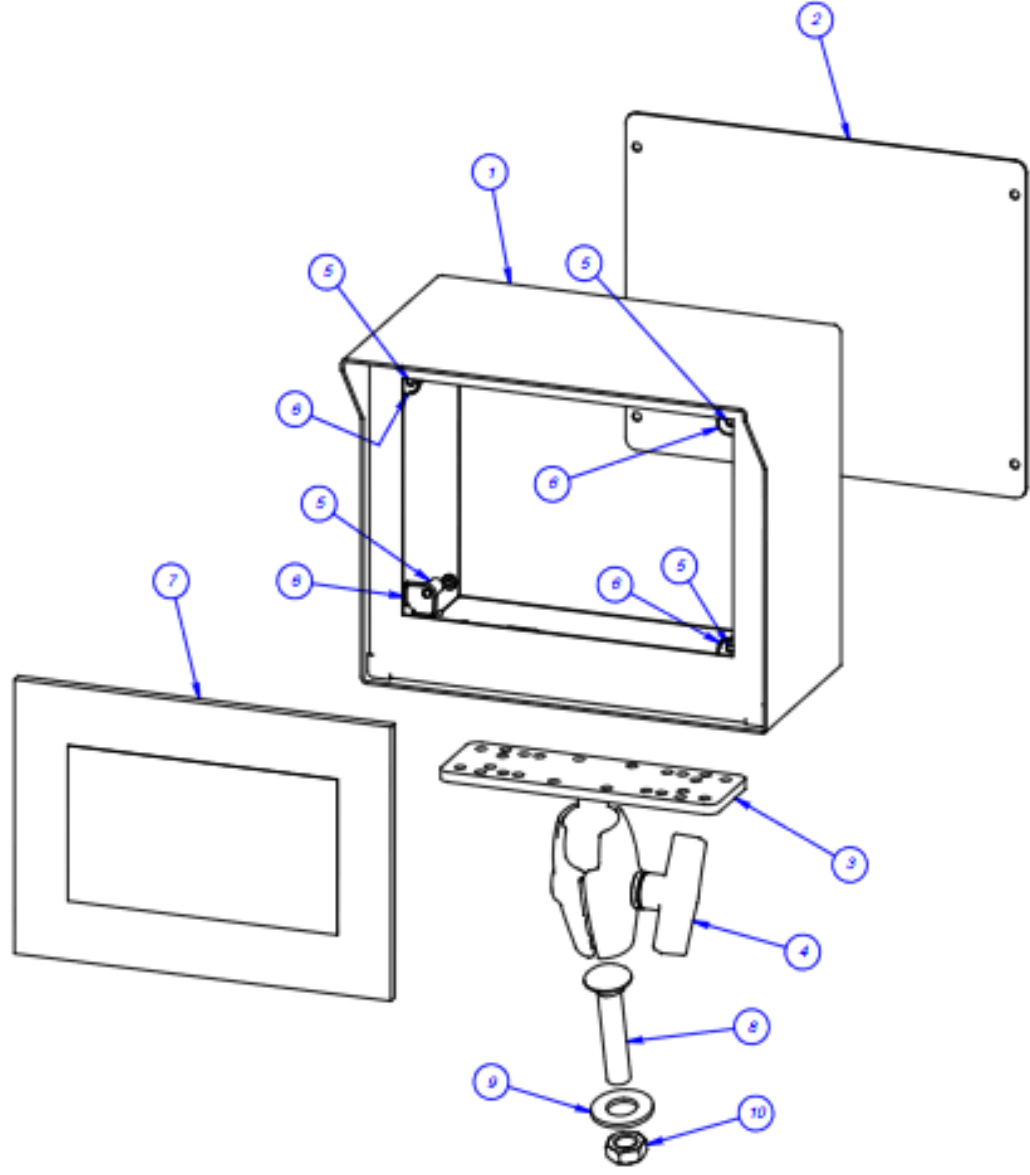

5.6 Accumulator Funnel Assembly

PN: TA-UC5000

ITEM NO.	QTY	PART NO.	DESCRIPTION
1	1	TP-T10MA9001	FRONT PANEL
2	1	TP-T10MA9002	LEFT SIDE PANEL
3	1	TP-T10MA9003	RIGHT SIDE PANEL
4	1	TP-T10MA9004	REAR PANEL
5	1	TP-T10MA9005	TOP BRACE
6	1	TP-T10MA9006	TOP COVER
7	1	TP-T10MA9007	FLAP
8	1	TP-T10MA9009	FLAP SHAFT
9	1	TP-T10MA9008	FLAP COVER
10	2	TP-T10MA9010	DEFLECTOR BLOCK
11	1	TP-T10MA9011	DEFLECTOR BLOCK – BOTTOM
12	1	TP-T10MA9012	CYLINDER MOUNT
13	1	TP-T10MA9013	CYLINDER BASE
14	1	TP-T10MA9014	MOUNTING ANGLE
15	2	TP-T10MA9015	TOP BRACE SPACER
16	1	TP-T10MA9016	PALM GRIP
17	1	TP-T10MA9017	COVER HINGE
18	1	TP-109164	3-ARM PHENOLIC KNOB
19	1	TP-111102	CLAMP COLLAR
20	1	TP-109162	CLAMPING KNOB ¼-20
21	1	TP-403269	TRUNNION BRACKETS
22	1	TP-403267	CYLINDER 3-4" X 2
23	1	TP-403268	PISTON ROD CLEVIS
24	2	TP-115100	MAGNETIC CATCH

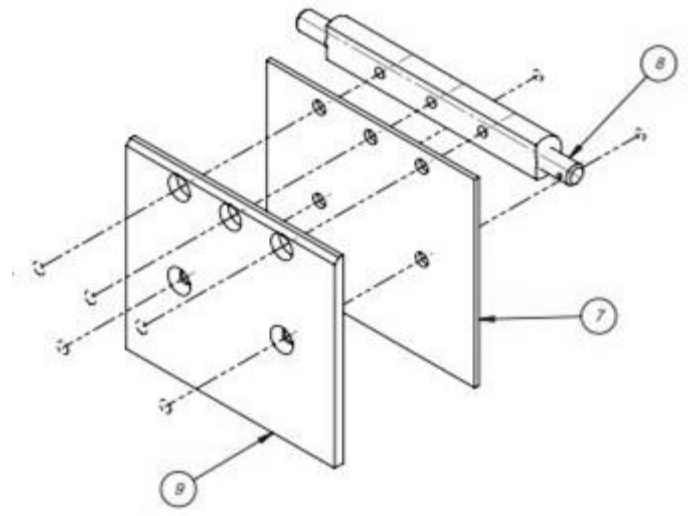
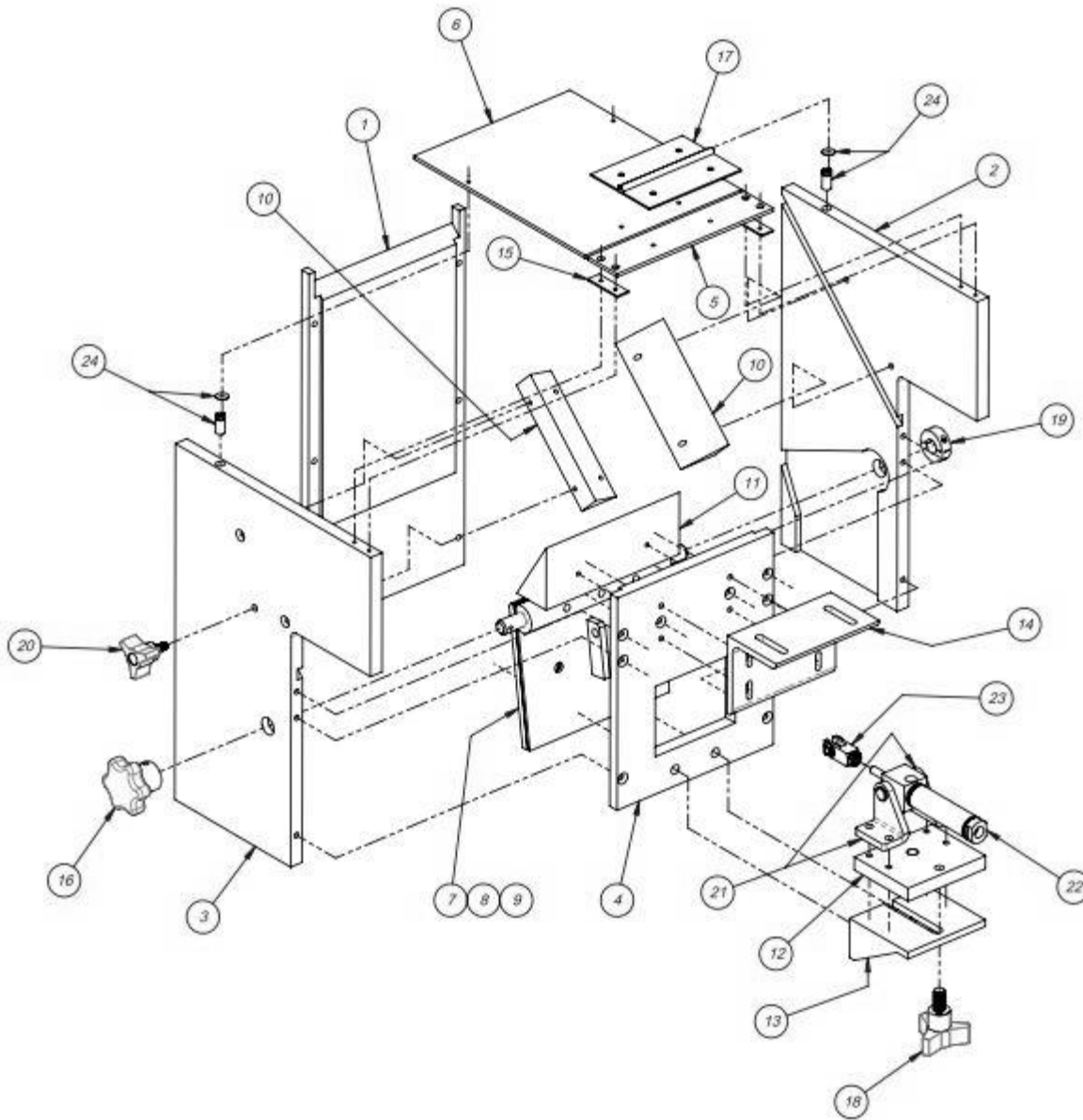

Detail of items 7, 8 and 9

5.7 Optical Eye Assembly

PN: TA-UC5560

ITEM NO	QTY	PART NO.	DESCRIPTION
1	1	TP-UC5560	EYE
2	1	TP-UC5561	EYE CABLE
3	2	TP-T10MA5562	EYE MOUNTING BRACKET

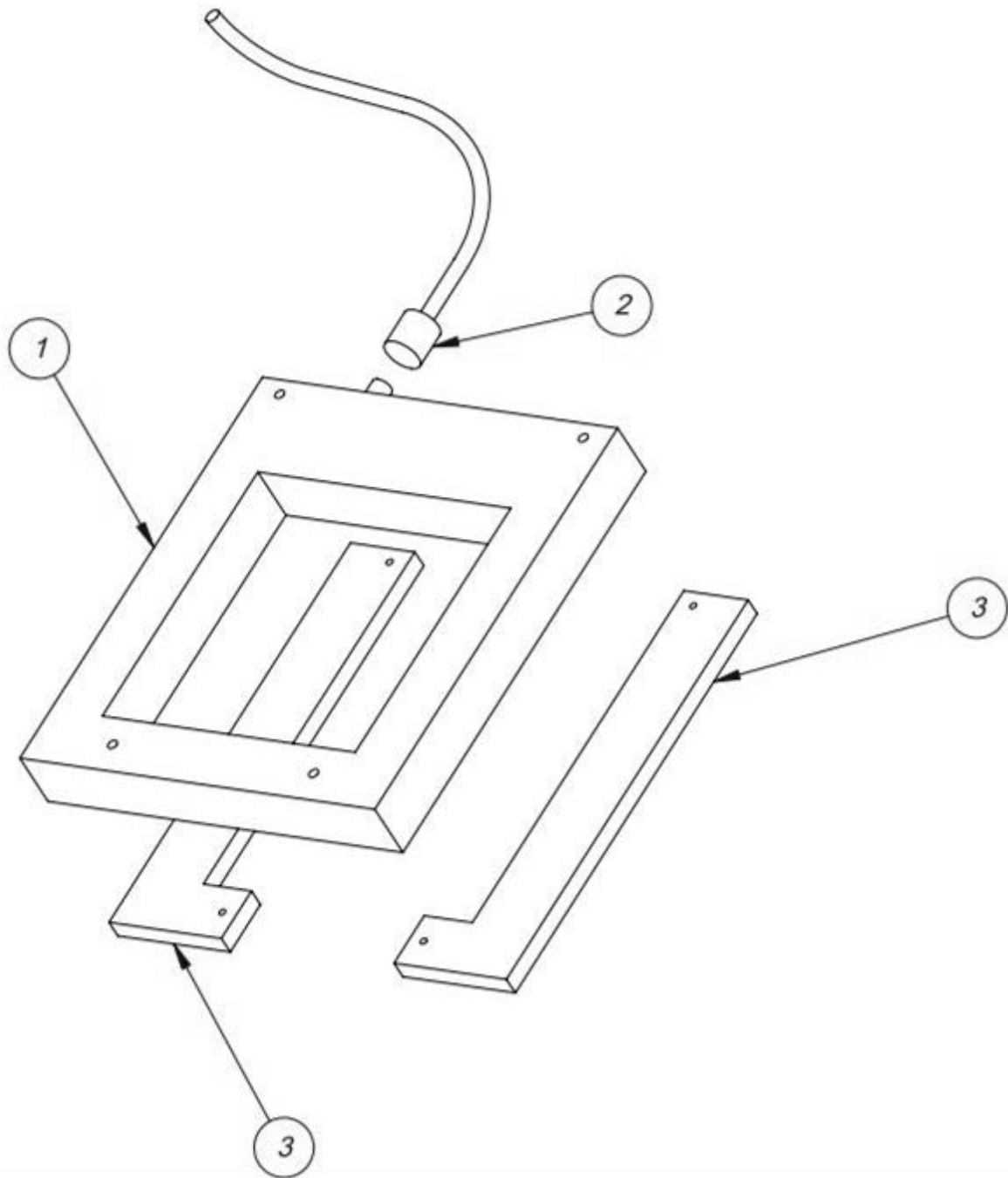

OPTICAL EYE ASSEMBLY

PN: TA-UC5560

5.8 Supply Hopper Assembly

PN: TA-UC6500

ITEM NO	QTY	PART NO.	DESCRIPTION
1	1	TP-T10MA6501	HOPPER
2	2	TP-T10MA6502	ANGLE MOUNT
3	1	TP-T10MA6503	VERTICAL SUPPORT TUBE
4	1	TP-T10MA6504	VIBRATORY SHELF
5	1	TP-T10MA6505	PAN VIBRATORY TRAY
6	2	TP-T10MA6506	HOPPER GATE
7	2	TP-T10MA6507	CLAMP BAR
8	1	TP-T10MA6508	VERTICAL SUPPORT TUBE
9	8	TP-120150	U-BOLT ¼ - 20
10	1	TP-224005 + (4) TP-110761	VIBRATORY DRIVE AND MOUNTS
11	2	TP-109105	NYLON PAD
12	2	TP-109104	THUMB SCREW KNOB

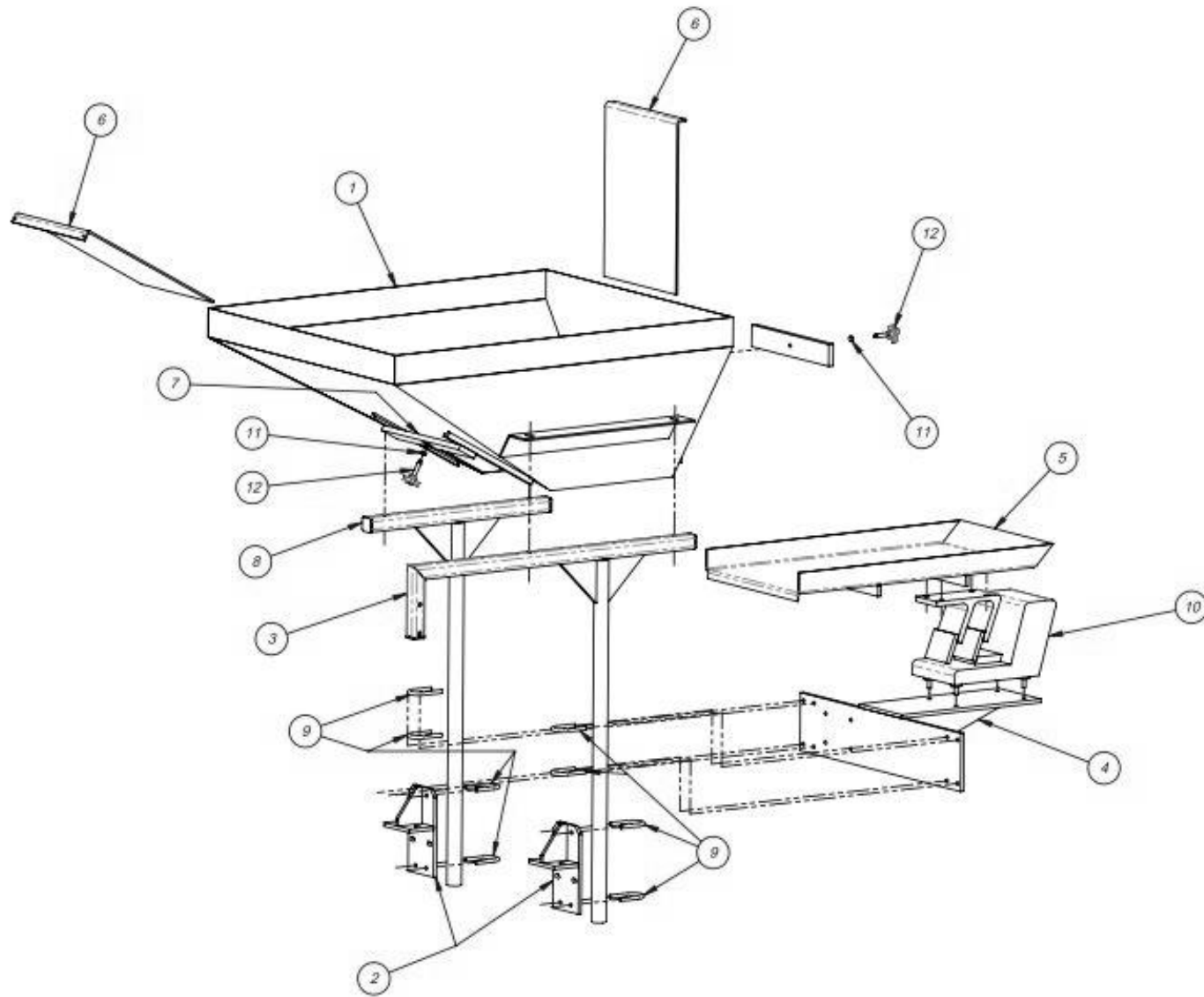

SUPPLY HOPPER ASSEMBLY
PN: TA-UC6500

5.9 CCW Vibratory Bowl Assembly

PN: TA-UC7000

ITEM NO	QTY	PART NO.	DESCRIPTION
1	1	TP-720122	24" BOWL AND DRIVE
2	1	TP-T10MA0043	CCW SKIVER
3	1	TP-109161	CLAMPING KNOB

*NOTE: If you purchased the UC-2400 with the **Clockwise Bowl Configuration**, Item 1 is replaced with TP-720122-1 and Item 2 is replaced with TP-T10MA0043-1. Item 3 is the same for both configurations.*

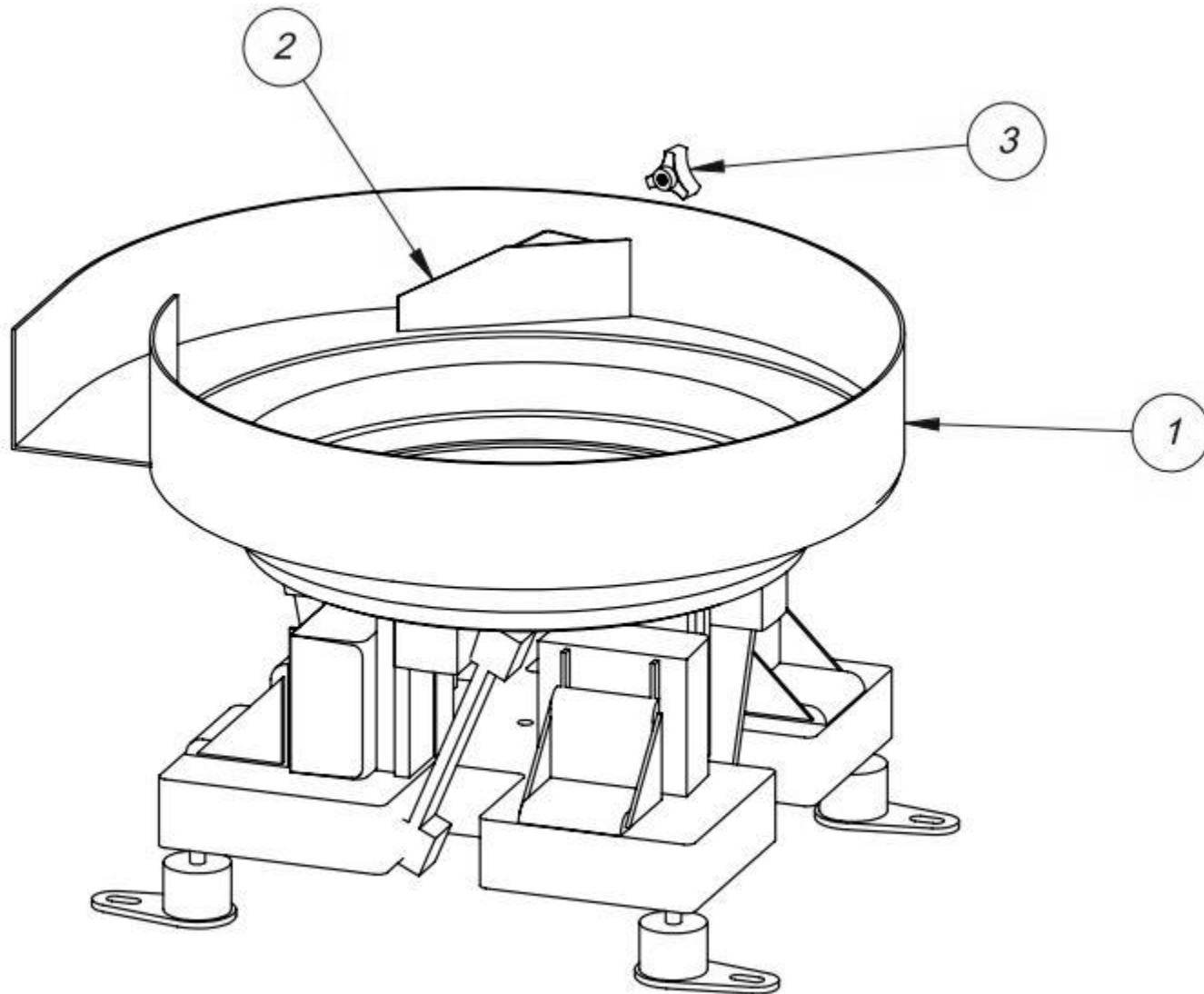

5.10 Prox Sensor Assembly

PN: TA-UC8000

ITEM NO	QTY	PART NO.	DESCRIPTION
1	1	D9-101875-100	PROX SENSOR BRACKET
2	1	TP-216143	PROXIMITY SENSOR

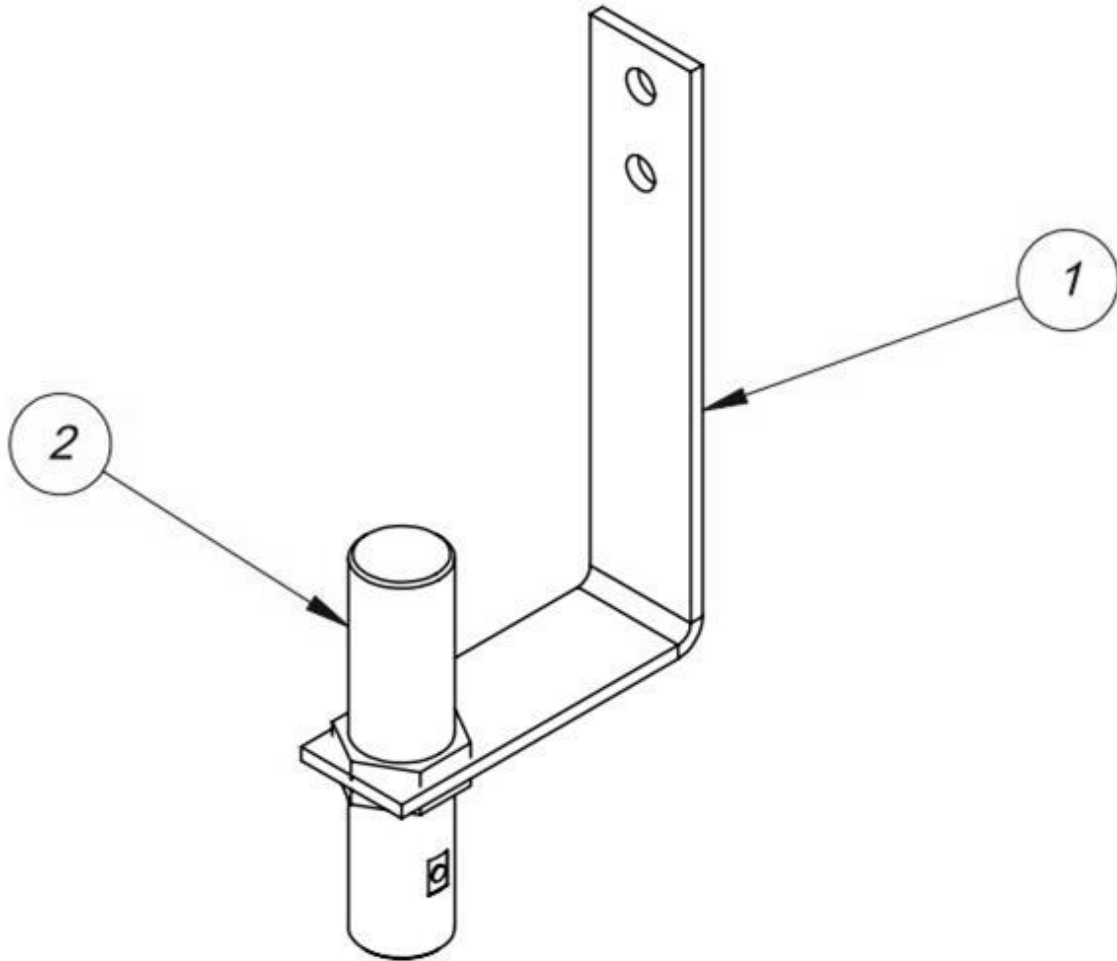

5.11 Ultra-Count Stand

PN: TA-UCSTAND

ITEM NO	QTY	PART NO.	DESCRIPTION
1	1	TP-T10MA0202	BASE WELD
2	1	TP-T10MA0203	UPPER COLUMN
3	1	TP-T10MA0204	LOWER COLUMN
4	4	TP-110764	LEVELING MOUNT
5	1	TP-T10MA8021	SUPPORT ANGLE
6	1	TP-T10MA8027	BASE FOR 24" BOWL WELDMENT
7	1	TP-T10MA8032	SUPPORT SHELF

NOTE: Stand is optional on multiple UC-2400 systems.

Rectangular

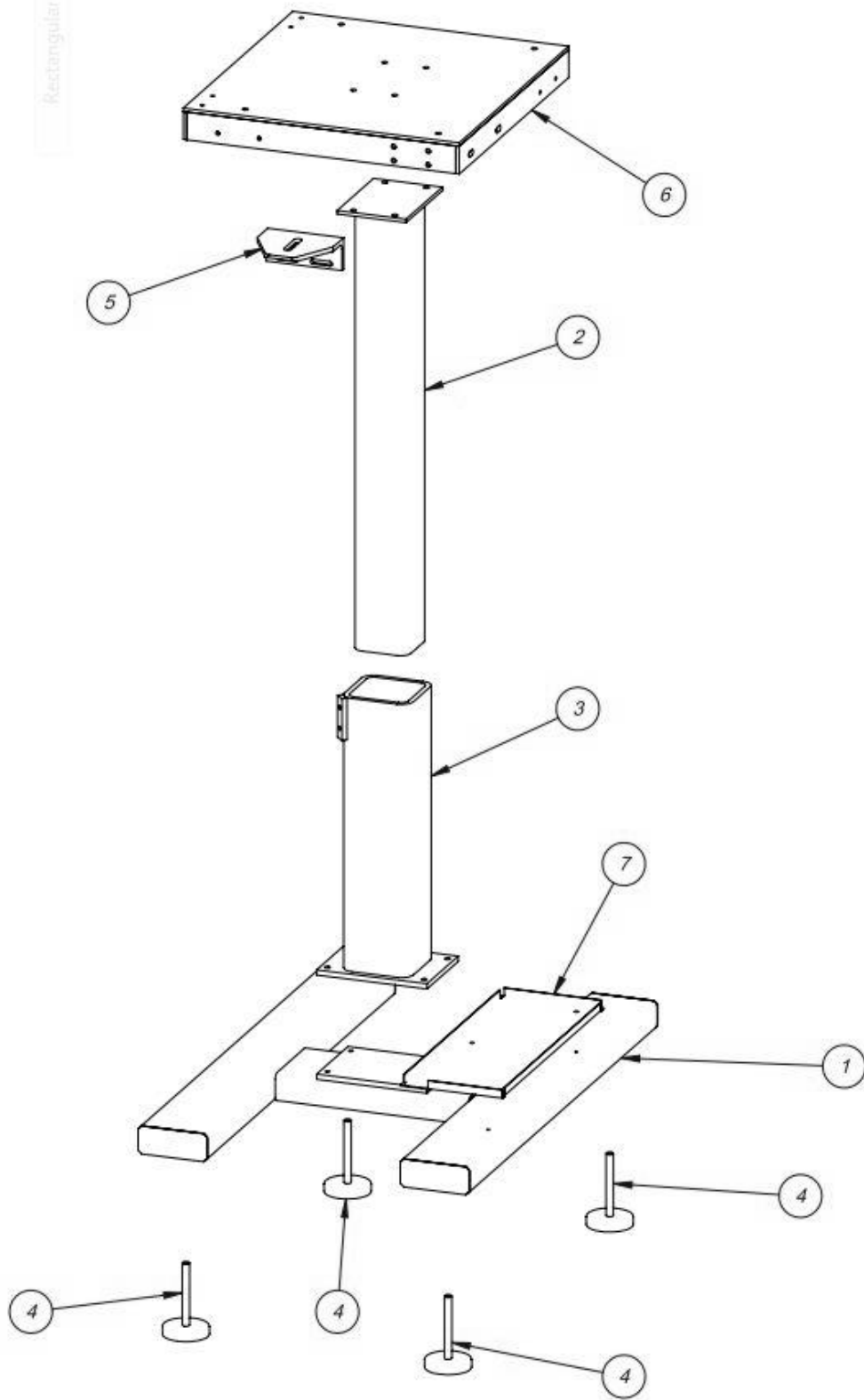

5.12 Ultra-Count 3000 System Layout

T-UC3000

ITEM NO.	PartNo	DESCRIPTION	QTY.	Page No.
1	TA-UC3STAND	STAND ASSEMBLY	1	69
2	TA-UC1000-DC	ELECTRONICS ASSEMBLY	1	41
3	TA-UC2000-DC	CABLE ASSEMBLIES	1	43
4	TA-UC2400, UC5000	V-TRACK & ACCUMULATOR	1	45-52, 56
5	UC-3000	IOP ASSEMBLY	2	53
6	TA-UC5560	OPTICAL EYE ASSEM.	1	57
7	TA-UC6500-1	SUPPLY HOPPER ASSEMBLY	1	71
8	TA-UC7030	30" CCW BOWL ASSEMBLY	1	73

*NOTE 1: If you purchased the UC-3000 with the **Short V-Track configuration**, your part numbers are the same as those listed above, with the following exception: Item 4 V-Track is replaced with TA-UC2400-SDC.*

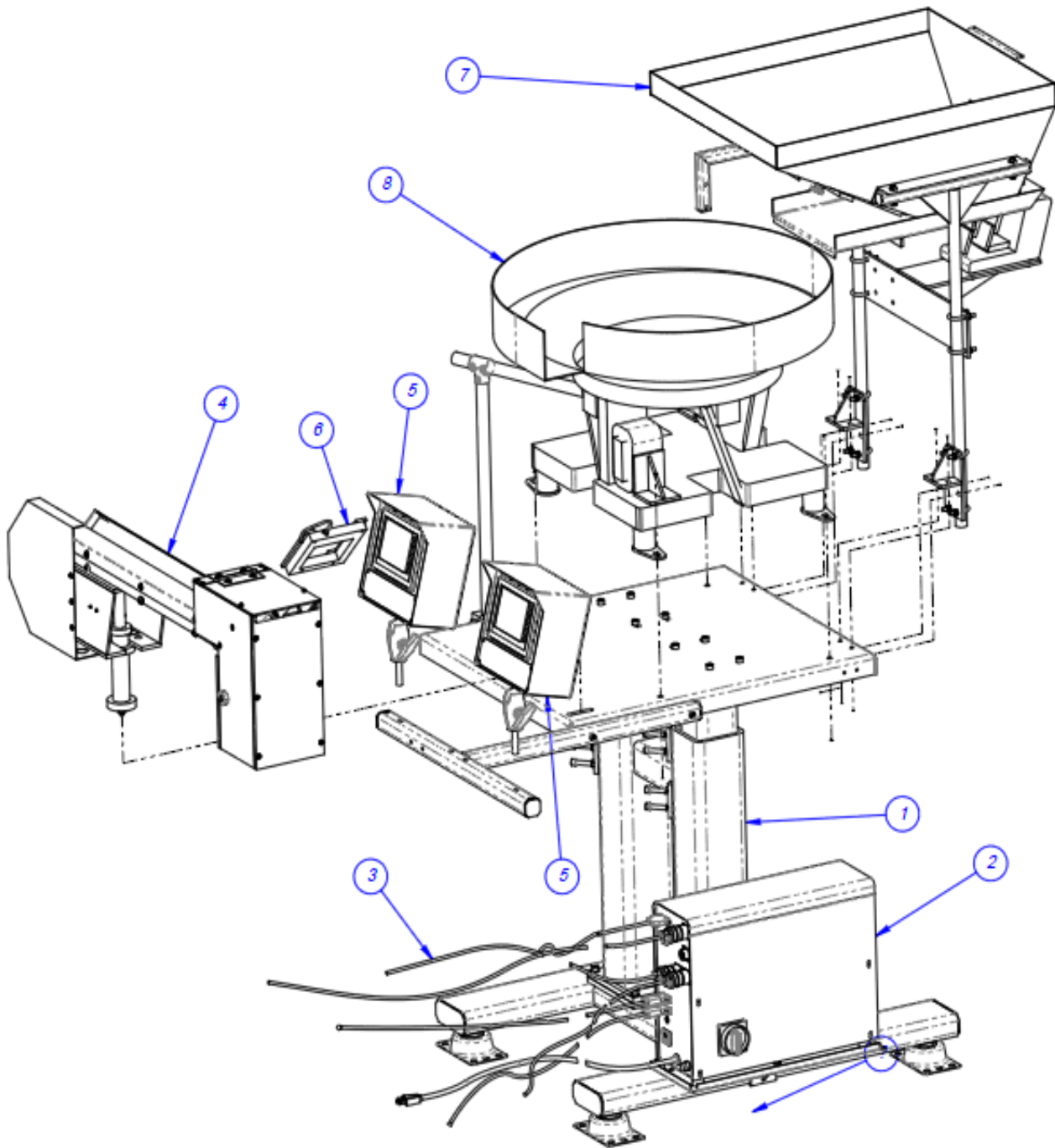

5.13 UC-3000 Stand Assembly

TA-UC3Stand

ITEM NO.	PartNo	DESCRIPTION	QTY.
1	TP-110740	Seismic Bolt-Down Vibration-Damping Mounts	4
2	TP-T10MA3001	BASE WELDMENT	1
3	TP- T10MA3002	LOWER COLUMN	1
4	TP-T10MA8032	SUPPORT SHELF	1
5	TP- T10MA3004	BOWL BASE	1
6	TP- T10MA3003	UPPER COLUMN	2
7	TP-T10MA3006	MODULE BRACKET	1
8	TP- T10MA3005	TOUCH SCREEN MOUNT	1
10	TP- T10MA3010	HORTL. PROX POST	1
11	TP- T10MA3008	VERTICAL PROX POST	1
12	TP-111215	JOINING TEE	1
13	TP- T4MA5123	CLAMP BLOCK	1
14	TP- T10MA3007	PROX MOUNT	1
15	TP-216142	PROX SENSOR	1

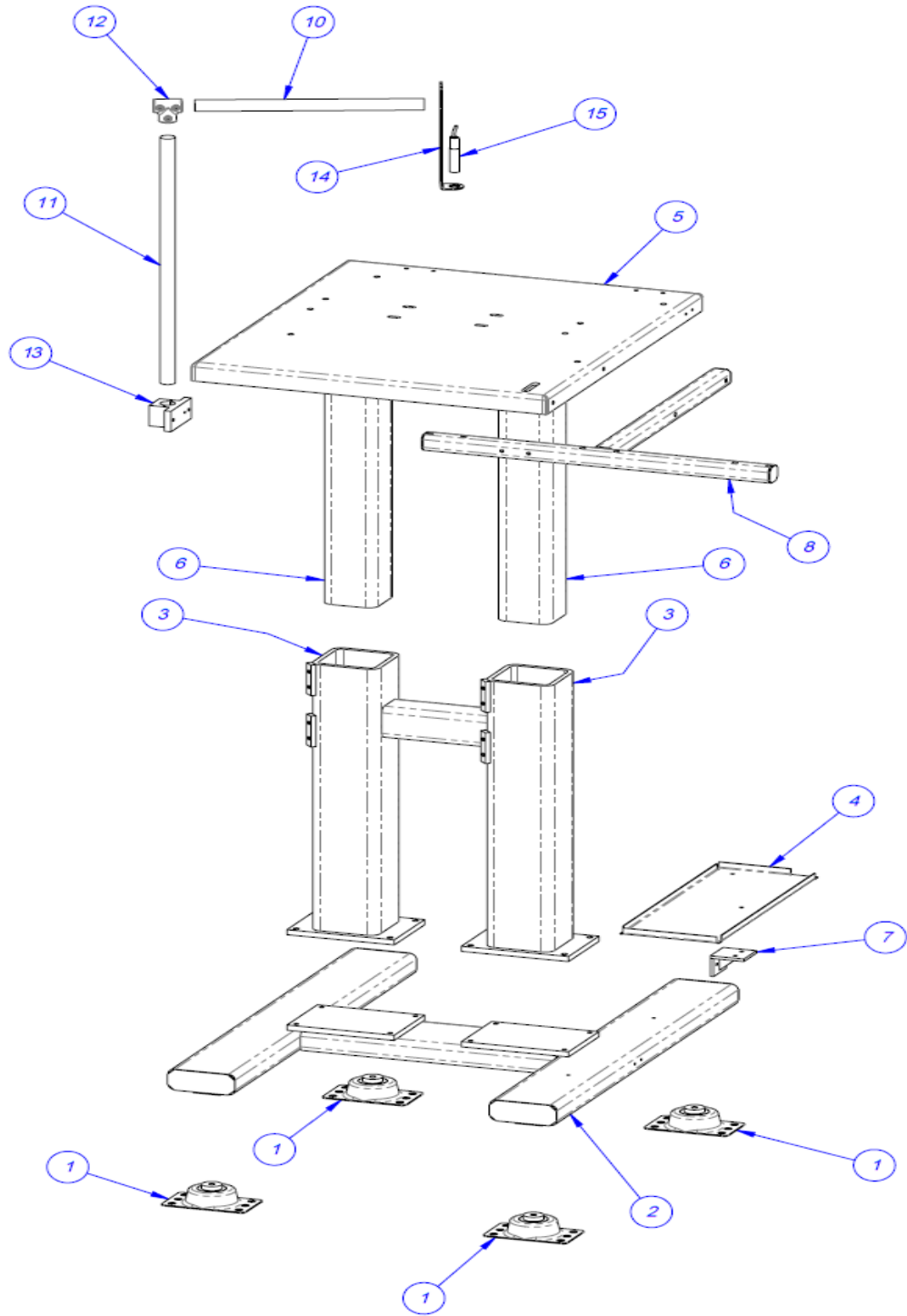

5.14 UC-3000 Supply Hopper Assembly

TA-UC6500-1

ITEM NO.	PartNo	DESCRIPTION	QTY.
1	TP-T10MA6501	HOPPER	1
2	TP-T10MA6502	ANGLE MOUNT	2
3	TP-T10MA6504	VIBRATOR SHELF	1
4	TP-T10MA6505	PAN VIBRATORY TRAY	1
5	TP-T10MA6506	HOPPER GATE	2
6	TP-T10MA6507	CLAMP BAR	2
7	D9-140135-701	VERTICAL SUPPORT TUBE	1
8	D9-140135-702	VERTICAL SUPPORT TUBE	1
9	TP-120150	U-BOLT 1/4-20	8
10	TP-224005 + (4)TP-110761	VIBRATORY DRIVE & MOUNTS	1
11	TP-109104	THUMB SCREW KNOB	2
12	TP-109105	NYLON PAD	2

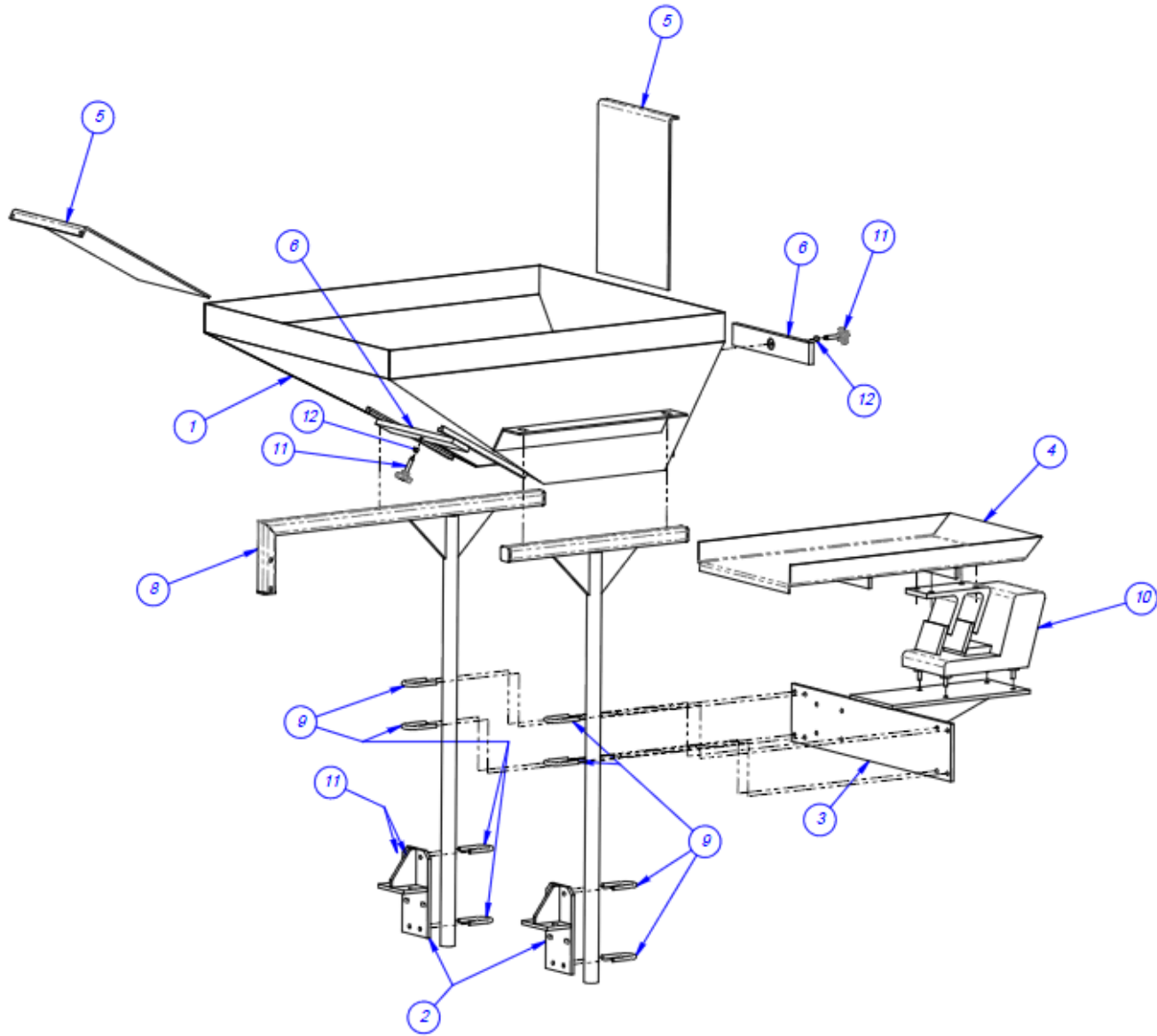

5.15 30 Inch Counter Clockwise Bowl Assembly

TA-UC7030

ITEM NO.	PartNo	DESCRIPTION	QTY.
1	TP-720123	30 INCH BOWL & DRIVE	1
2	TP-T10-MA0043-30	SKIVER	1
3	TP-109161	CLAMPING KNOB	1

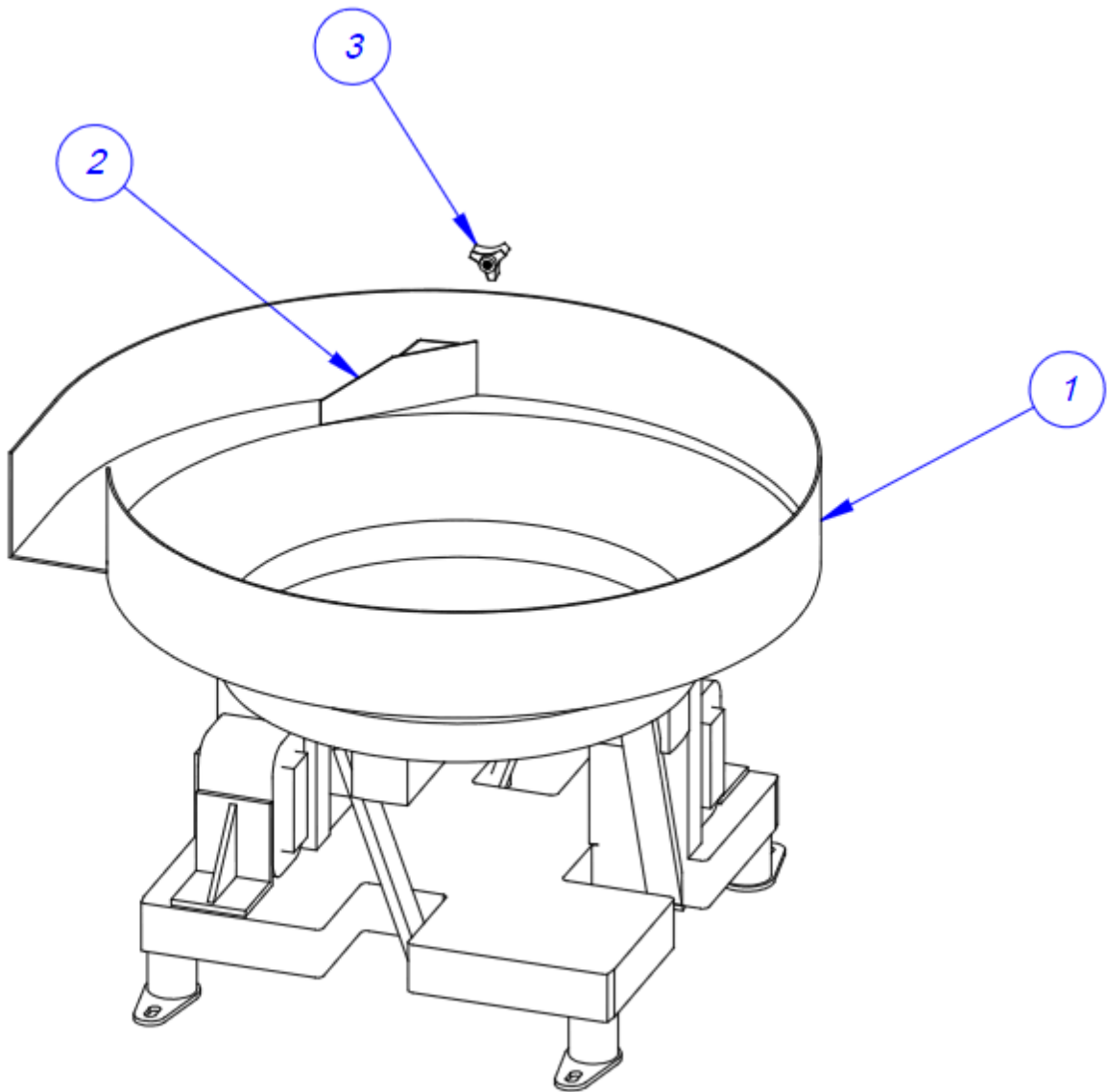

110 VAC Electrical Drawing

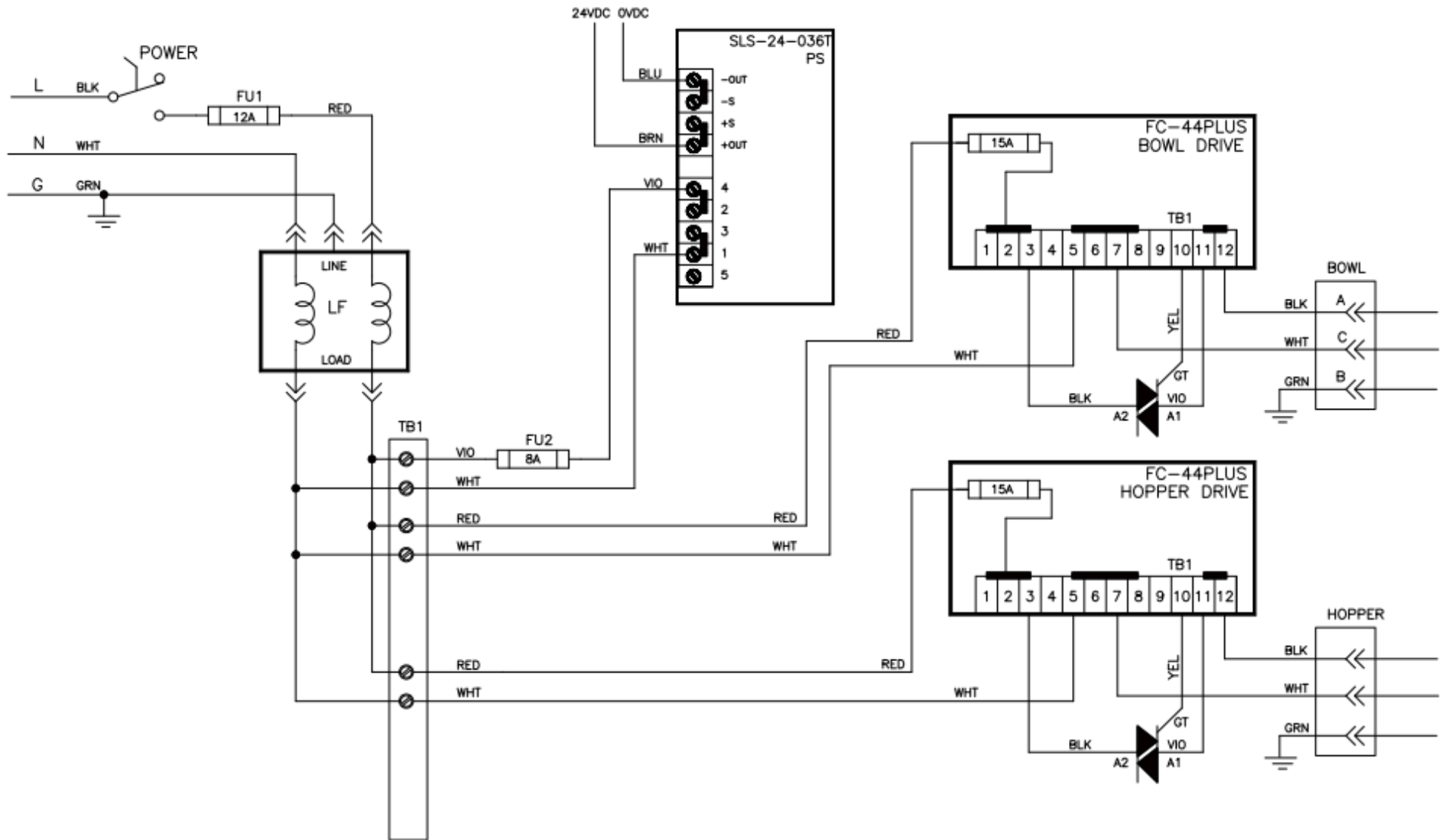

FPG I/O Electrical Drawing

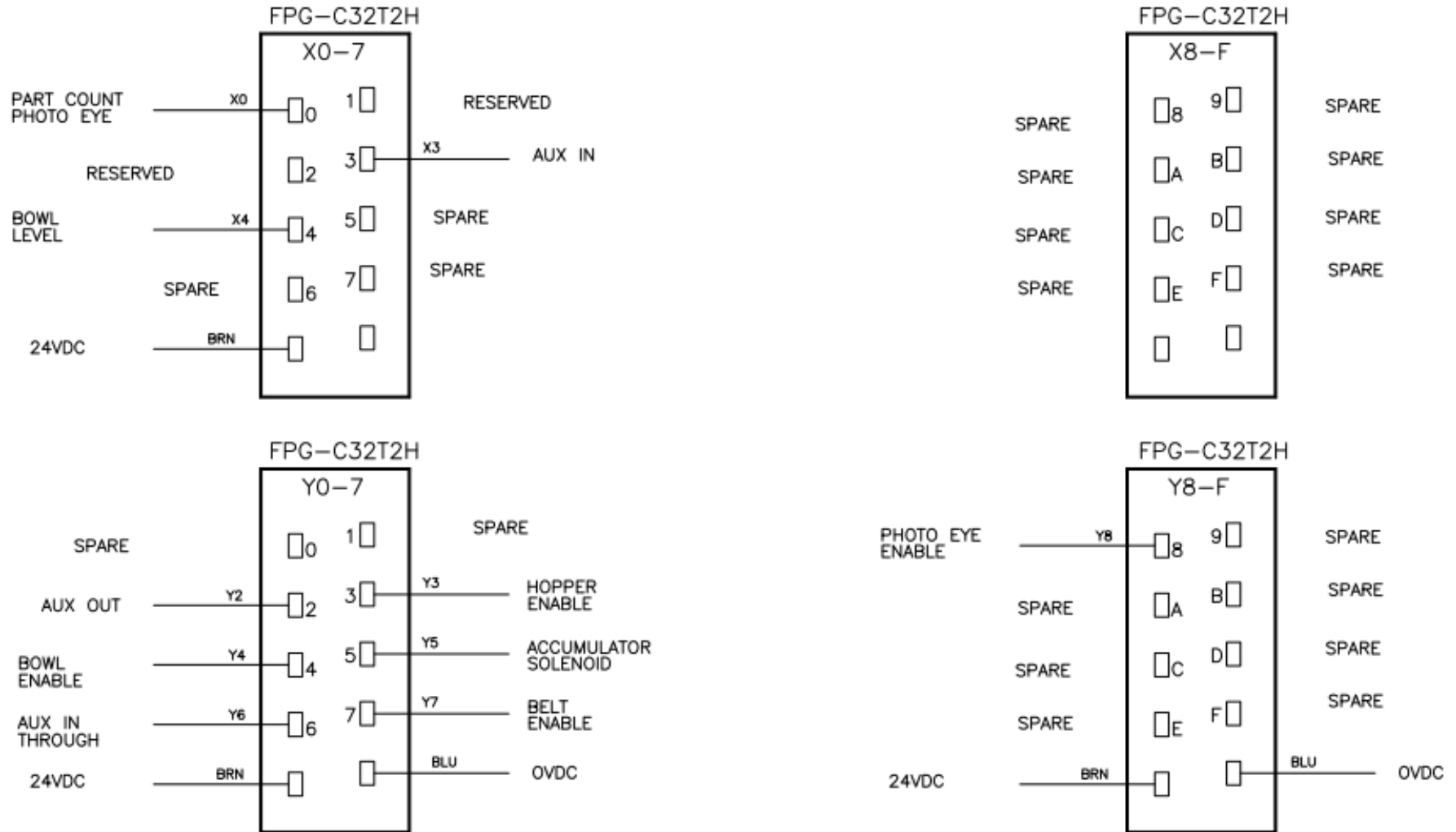

NOTE: PART COUNTING INPUT HAS TO BE SWITCHED FROM X2 TO X0.

Analog Control Electrical Drawing

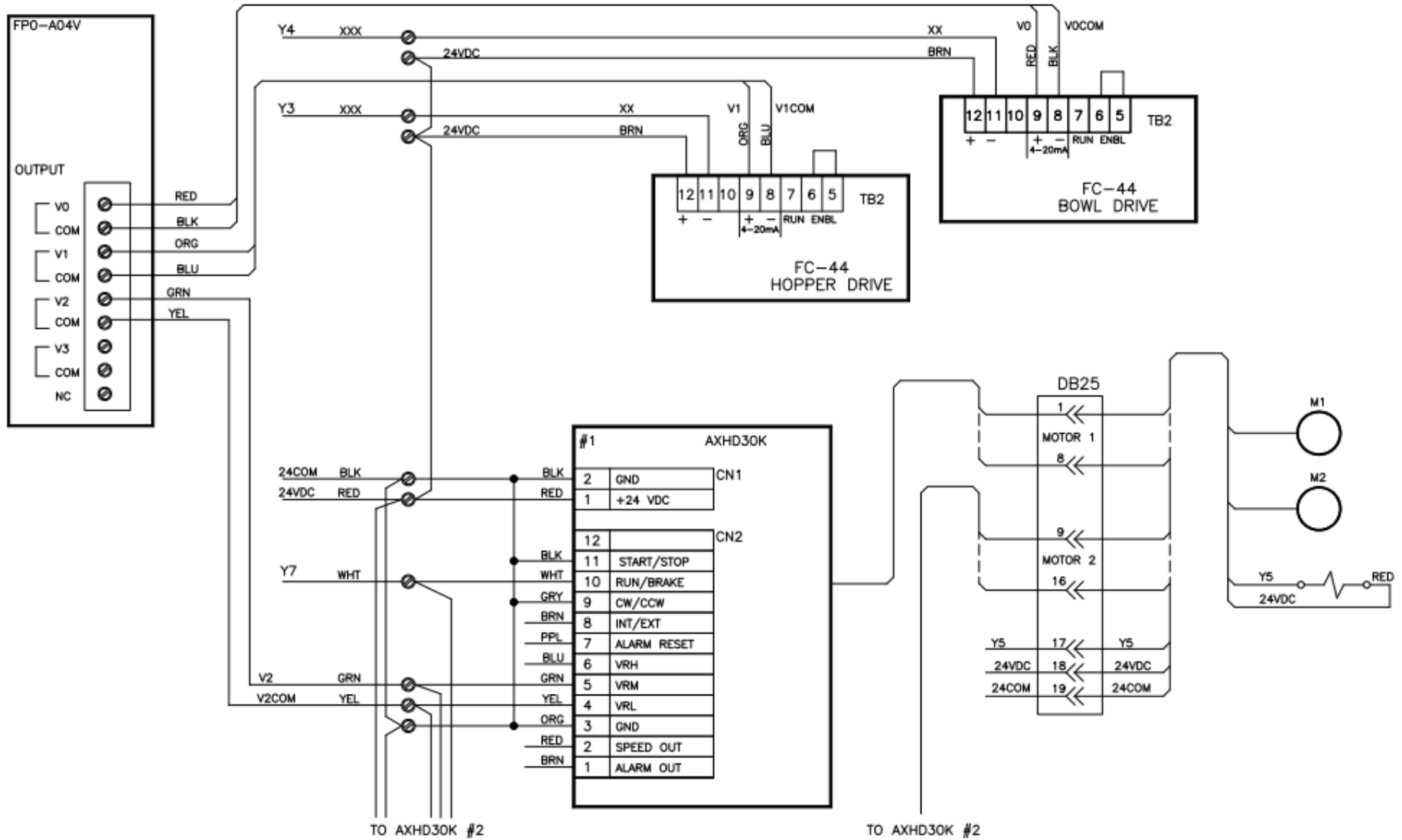

DB9 Electrical Drawing

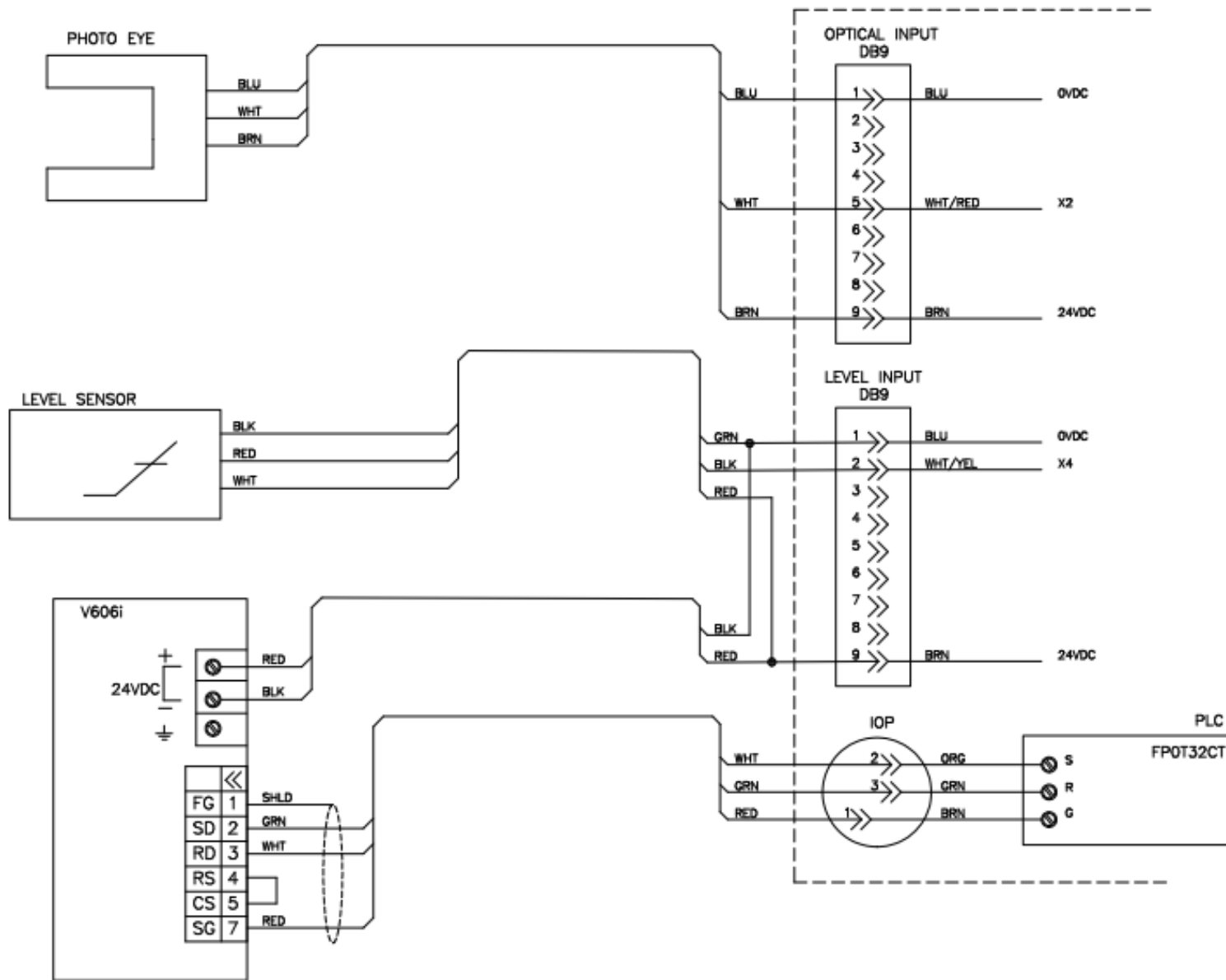

DB25 Electrical Drawing

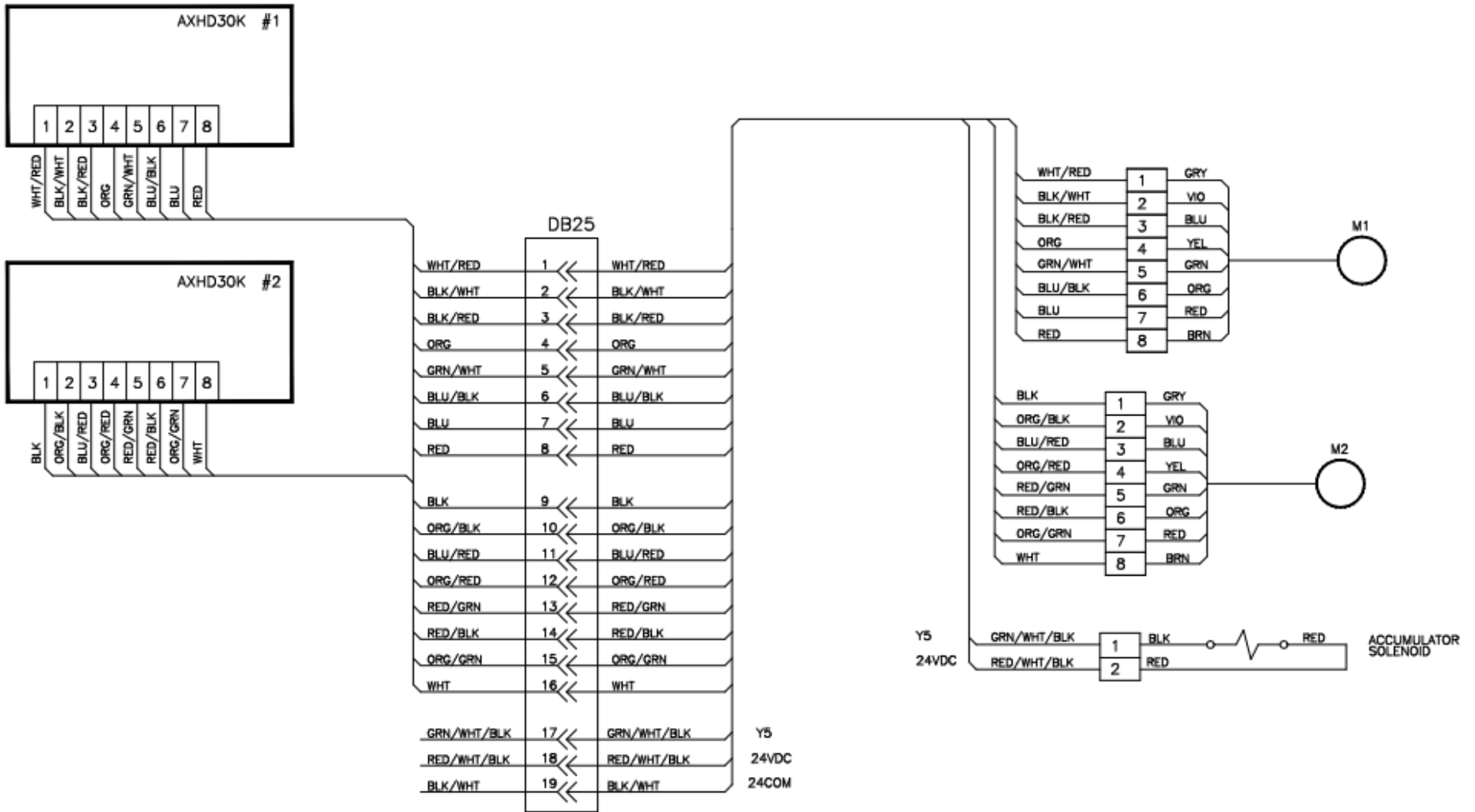

Aux Interface Electrical Drawing

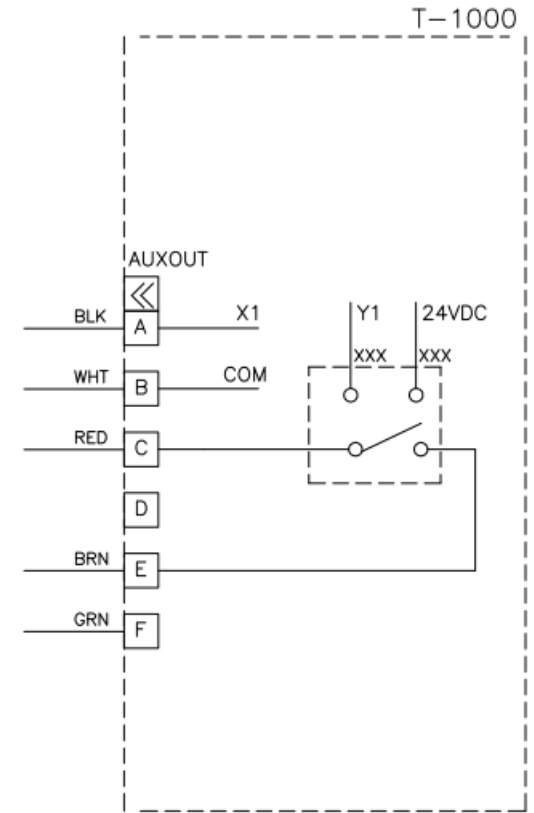
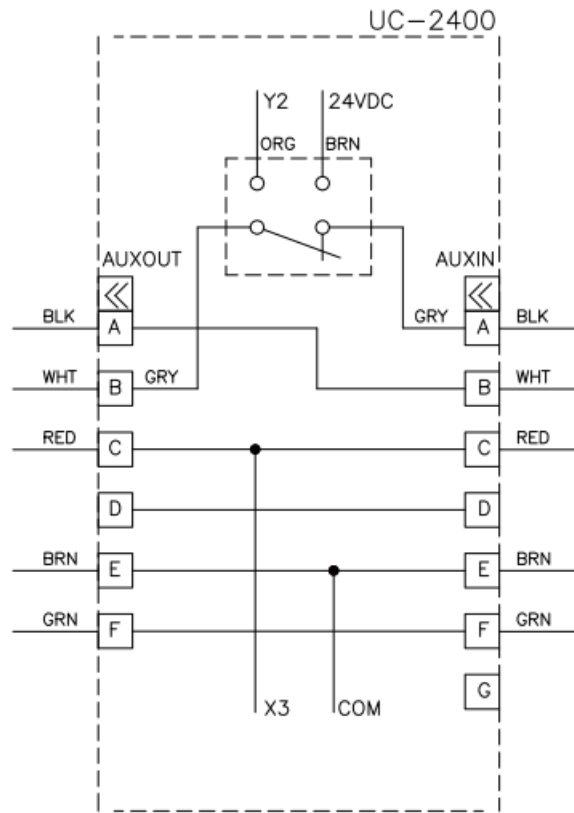
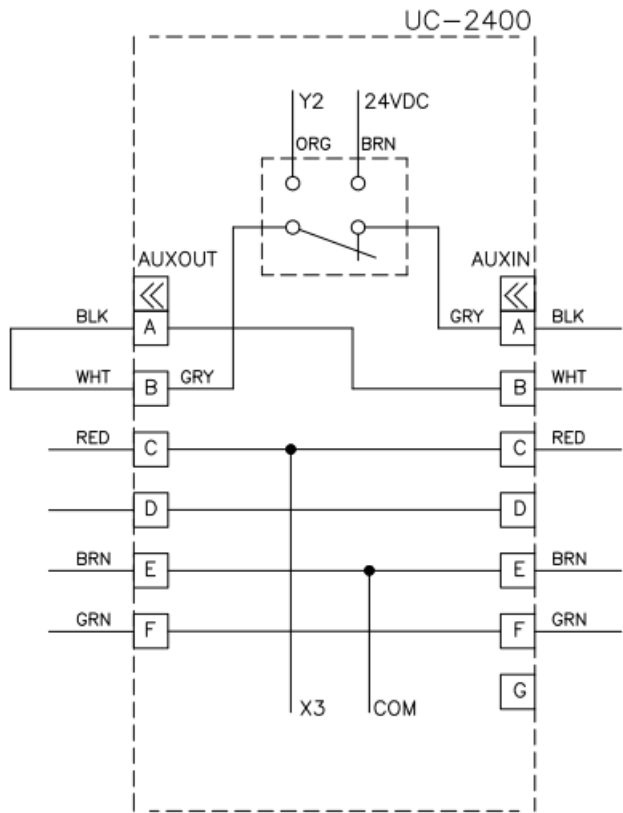

Appendix

Detailed Setup Procedure

A. Ultra-Count System Detailed Setup Procedure

The following sections provide detailed, step-by-step instructions on how to set up the UC-2400 and UC-3000, perform parts tests, adjust eye settings and troubleshoot inaccurate counts.

I. Counter Setup

The setup procedure for the Ultra-Count Parts Counter is a two part process: 1) **Bowl Setup** and 2) **Eye Setup**.

Bowl Setup refers to mechanical and touch screen settings that cause parts in the bowl to flow properly. More specifically, these settings and adjustments cause the parts to feed so that one part passes through the eye at a time with a consistent separation of parts. Do not proceed to Eye Setup procedures if parts are jamming or multiple parts are passing through the eye with no or insufficient separation.

Eye Setup refers to touch screen and optical frame pot settings that affect the accuracy of counts. The Eye Test Screen allows for testing to ensure accurate counts. Pot settings on the eye will also affect the accuracy of counts.

Due to the highly technical nature of these procedures, more experienced setup personnel may be required. Bowl and Eye Setup processes require sufficient testing, over a period of time, to ensure that each process is accurate.

II. Procedure

Step 1: Ensure proper and consistent level of parts in the bowl.

The correct level of parts in the bowl is the level that allows most of the center cone (floor) to be free of parts. Because of the cone shape, parts will feed to walls of the bowl. The Hopper Settings screen provides for hopper timing and vibration levels. The position of the level sensor in the bowl can also be adjusted to cause the proper level of parts in the bowl.

NOTE: The level of parts must not be at a high level to prevent parts from falling off the slide drawers.

Step 2: Ensure proper parts separation in the bowl.

The proper parts flow is the flow that allows only one part to fall on the V-track belt at a time as the parts exit the bowl. Wipers are provided to brush off parts that stack and drawers are provided to reduce the width of the bowl track so that only one line of parts goes around the bowl.

Improperly set wipers can also cause parts to jam. This is a delicate setting that requires a lot of testing to prevent jamming and wiping off of parts. Additionally, vibration levels in the Settings screen can be adjusted (Fast/Slow bowl speed) to cause separation.

NOTE: You MUST have good parts flow from the bowl before attempting any setup of the counting eye. The parts must be dropping from the discharge of the bowl onto the V-track belt one at a time, every single time, with a minimum 4" gap on the V-track belt between each part. If this is not done correctly you may experience inaccurate counts. If the parts are overlapping or stacked on top of each other you also may experience inaccurate counts.

Step 3: Ensure the eye is clean.

Use a cotton cloth and a mild glass cleaning agent. Spray the cleaning agent on the cotton cloth, not directly on the eye.

Step 4: Perform single part testing.

Single part testing is used to ensure that for every single part that passes through the eye, a count of one is achieved. The single part test is also performed to assist with determining the Min and Max settings, which are set on the Eye Settings Screen.

Most parts will run fine with a Belt Speed of 99. Any changes to the Belt Speed will change the readings from the eye and will make it necessary to restart the testing procedure. Adjust the belt speed to 99 on the Settings screen to perform this test. Speeds lower than 99 may be required if parts continue to move after the belt stops. APPI recommends as high a belt speed as possible to increase the gap between parts. The eye must be set to the most sensitive pot setting, but output must NOT stay on continually.

From the Main Menu, press the **Settings** menu button, then the **Eye Setting** menu button, then the **Eye Test** menu button. Press the **Start** toggle button to start the belt. At this point, the belt will run, but the bowl will not. When all parts are off the belt, press the **Reset** button. Then drop one part onto the V-track belt while looking at the Eye Test screen. One part must be detected as one part before dropping any further parts. The Eye Test screen will show the test results from the last nine parts dropped. Every time a part is placed on the conveyor, one part must be detected.

Drop one part at a time, but drop them in every possible orientation so the eye has a chance to see them from every angle. Observe the Min and Max readings at the bottom center of the screen. Continue to drop parts (one at a time) onto the V-track belt until you no longer see any change in the Min or Max readings. If the Min or Max values change, continue to drop one part at a time, again, until these two values do not change.

NOTE: While the Eye Test screen shows you the last nine part readings, there is no limit to the number of parts that can be used while performing the Eye Test.

NOTE: The purpose of dropping parts by hand ensures that there is no scrap in the parts dropped onto the belt. Additionally, dropping one part at a time ensures that there is proper separation and no overlapping occurs. Overlapping could produce improper Min / Max results.

If no part is detected, or one part is detected as two inputs, then eye pot settings must be adjusted. Normally the pot settings do not need to be changed from MOST SENSITIVE and LEAST DURATION.

Pot Setting – Sensitivity: Sometimes one part is counted as two because the eye is too sensitive. By turning DOWN the sensitivity, any leading or trailing smaller parts may be ignored by the eye. The goal is to have the part detected as one part. You can test for sensitivity of the eye by using an Allen key. Starting with 1/8", with the key on the centerline of the field, perpendicular to the detection field, pass the key the entire length of the eye. At the most sensitive setting, the output should remain ON the entire time the key is in the detection field.

Pot Setting – Duration: Sometimes a small part sends a very short output to the counter PLC which may not be detected by the PLC. The duration pot can increase the length of the output so that the PLC detects in the eye output every time. However, if the output is too long, a second part may not be detected causing an overcount.

Step 5: Perform single part testing after eye pot settings adjustments.

After pot settings are adjusted, perform the single part test as described in Step 4. Continue to perform the Single Part Test until you are absolutely sure that one part dropped onto the belt is always counted as one part. You will notice that the part length Min / Max values will increase as the duration setting is increased.

Step 6: Perform part gap testing (two parts): A gap test can be performed to ensure that duration pot setting is optimal (not too long a period of time) and also determine how close parts can be on the belt to ensure proper accuracy of counts.

While still on the Eye Test screen, stop the V-track belt, press the **Reset** button and place two parts on the stopped belt with a 1/4" gap between the parts. Start the belt, and then check to make sure the counter saw exactly two parts. If the counter saw the two parts as one part, stop the belt and place the parts further

apart. Continue to test, increasing the gap, until the count results are two. Adjust the Duration Pot to increase or reduce the gap, as required.

If the duration output is too high, the output will still be ON when the second part starts to pass through the eye. This will cause overcounts since the first pulse being sent from the eye to the PLC overlaps the second pulse, causing it to look like one larger part instead of two smaller parts.

Turn the duration potentiometer down so that a minimal gap between parts is achieved and both parts are counted.

NOTE: If Eye Pot settings (Sensitivity or Duration) are changed, Step 4 must be repeated.

Step 7: Perform gap testing (five parts).

Perform the same gap test as described in Step 6, but this time with five parts. Carefully place them at the minimum distance determined to ensure the duration setting does not cause parts to be ignored by having too long an output. Then, start the belt and ensure that five parts are detected.

NOTE: As stated in Step 6, the gap test will determine the minimum gap required between parts to ensure that two parts passing through the eye at the minimum gap will always be counted as two. APPI recommends that the duration pot setting be the minimum required, but sufficient so that the PLC can detect even the shorted inputs from the eye.

Step 8: Adjust Min / Max settings.

Min / Max settings are provided to 1) filter parts and 2) deal with overlapping parts. Access the Eye Settings screen and adjust the Min / Max settings as required.

The Min setting can be used to filter parts such as scrap. However, if the good parts are less than 0.5", then you should not attempt to filter scrap as the part itself may be seen as scrap and thus not counted, causing an overcount. If your parts are clean and free from scrap, then the Min value should be set to zero (0). This will allow all parts to be counted; no filtering.

The Max setting can be used to count overlapping parts as two instead of one. However, if your parts are less than 1", then you should not attempt to count parts as two as this will cause undercounts. If your parts flow well and do not overlap, then set the Max setting to the highest value of 9.99 (no adding of counts).

If you wish to add a count whenever the maximum size is exceeded, toggle the **ON / OFF** button on the Eye Settings screen to ON. However, when turned on, the Double Count function may cause an undercount condition if the maximum setting is too low and one part is counted as two parts. To disable the Double Count function, toggle the **ON / OFF** button to OFF. This will set the Double Count setting to zero. However, if the Double Count function is turned off, an overcount condition may occur if parts are not properly separating when coming off the belt.

Min/ Max Setting of Zero for SMALL parts: By setting the Min and Max setting both to zero, the PLC will be set to the most sensitive and highest speed possible (Small Parts Function) which will provide the best programming to accurately count small parts. If your parts are less than 0.5", set the Min and Max settings to zero.

Step 9: Accept the Min / Max Settings on the Eye Test Screen.

As described in Step 3, the Eye Test Screen will also assist in setting the Min / Max settings on the Eye Settings screen. By pressing **Accept** on the Eye Test screen, the Min / Max "suggested" settings are accepted and transferred to the Eye Settings screen. However, the setting may need to be changed based on actual count accuracy testing.

The Min / Max settings as described in Step 8 are override settings that will prevent under/over counts for those instances described in Step 8.

NOTE: Accepting Min / Max settings may not always cause the system to accurately count your parts. You must test the Min / Max settings to ensure that they provide the level of accuracy you require. The Eye Test screen is available for testing of your parts to assist with the setup of the system, but the Min/Max settings must be thoroughly tested.

Step 10: Perform overlap testing (adds one to the count).

The counter has the ability to count overlapping parts as two parts. Disregard this test if your Max Setting is set to zero, or the highest value (9.99).

NOTE: Due to the margin of error of the PLC Eye Test Function (0.004), if the Max setting is too close to the actual part setting, one part may be counted as two, causing an undercount. Example: If during Single Part Testing the parts typically measure 0.008, but the Max is 0.012, the difference of 0.004 is within the margin of error. This would mean that one part may measure 0.012, but with one part automatically added to the count, an undercount would occur. Therefore, the Max setting must be set at least 0.005 higher than the highest tested part length. Otherwise, an undercount could occur.

On the Eye Settings screen, test for correct counting of overlapping parts by stopping the V-track belt and placing two parts on the belt with them overlapping each other. Start the V-track belt and check the screen to see if the counter saw two parts or one. For the counter to see it as two parts the measurement by the eye must be greater than the Max setting.

Anything measured less than the Max setting will be counted as one part. Anything measured more than the Max setting will be counted as two parts.

Step 11: Perform scrap testing.

The counter has the ability to filter parts that are below the Min setting (scrap). Disregard this test if your Min setting is set to zero.

NOTE: If the Min setting is too close to the actual part setting, one good part may be considered scrap and not counted due to the margin of error on the counter. Example: If during the Single Part Testing the parts typically measure 0.002, but the scrap setting (Min setting) is 0.004, then the difference is within the margin of error causing good parts to be counted as scrap. Therefore, the Min setting must be at least 0.005 less than the minimum tested part length.

Set the Min setting to zero if the minimum tested value is less than 0.006 or your part length is less than 0.5".

Step 12: Perform quality control testing.

After each mechanical, touch screen or eye setting is performed, counts must be tested to ensure that the counts are within your accepted level of accuracy. APPI suggests that every batch count be checked for quality for at least one hour after production starts. APPI recommends a check weigh scale for all automatic counting operations. However, manual scales (small platform scales) can be used to quickly count parts based on weight.

III. Troubleshooting Inaccurate Counts

NOTE: You MUST have good parts flow from the bowl before performing ANY troubleshooting. The parts must be dropping from the discharge of the bowl onto the V-track belt one at a time, every single time, with a suggested 4" gap on the V-track belt between each part. If this is not done correctly or if parts are overlapping or stacked on top of each other you may experience inaccurate counts.

Problem 1: Count is set to 25 but the bag contains 24 or less parts.

Possible Causes:

- A single part being measured by the eye is greater than the Max setting, meaning one part may have been counted as two.
 - *Solution: Increase the Max setting or disable the Max setting by changing the Max setting to 9.99.*
 - *Solution: Run eye test again to confirm the Max setting.*
 - *Solution: Set the Max setting to zero to disable the plus one function.*
- Scrap being measured by the eye is greater than the Min setting.
 - *Solution: Reduce the Min setting or change to zero.*

Problem 2: Count is set to 25 but the bag contains 26 or more parts.

Possible Causes:

- A single part being measured by the eye is less than the Min setting, meaning one part may not have been counted.
 - *Solution: Reduce the Min setting or change to zero.*
- Parts are too close together or overlapping on the belt.
 - *Solution: Reduce bowl speeds or increase belt speed.*
- Overlapping parts do not count as two parts.
 - *Solution: Decrease Max setting.*
- Two overlapping parts being measured as one part.
 - *Solution: Adjust settings to prevent overlapping parts.*
- Bowl speeds are too high.
 - *Solution: Reduce bowl speeds.*
- Slow count setting is too close to the fast count setting
 - *Solution: Reduce the slow count setting.*
- Parts are too small to be detected 100% of the time by the PLC
 - *Solution: Change to Small Parts Function by changing the Min setting to 0 and the Max setting to zero.*

IV. Setup Procedure Summary

Proper parts flow is absolutely required prior to performing eye tests, touch screen settings and eye pot adjustments. Hopper level components and programming adjustments are provided to maintain a consistent low level of parts in the bowl. Special tooling (slide drawers and wipers) are provided to achieve good parts separation. By making adjustments to the bowl, good parts flow can be achieved for a wide variety of parts.

The Counter Eye Test screen, filter programming and overlap programming and eye pot settings are provided to achieve accurate parts counts. However, counts must be checked for accuracy, and adjustment must be made to improve the counts. The Small Parts Function is provided by setting the Min / Max settings both to zero. This allows the PLC to detect small inputs from the eye faster and more reliably.

Each setting on the touch screen must be completely understood before attempting to perform adjustments. Adjusting one setting to correct overcounts may then cause undercounts. A thorough understanding of each adjustment is necessary. Become familiar with the Operation Guide and use these procedures to further assist your understanding of the system. Contact APPI Customer Support with any questions regarding this information.