

# Ti-1000ZR

---

Operation Guide, Version 1A  
Setup, Operation and Parts Manual

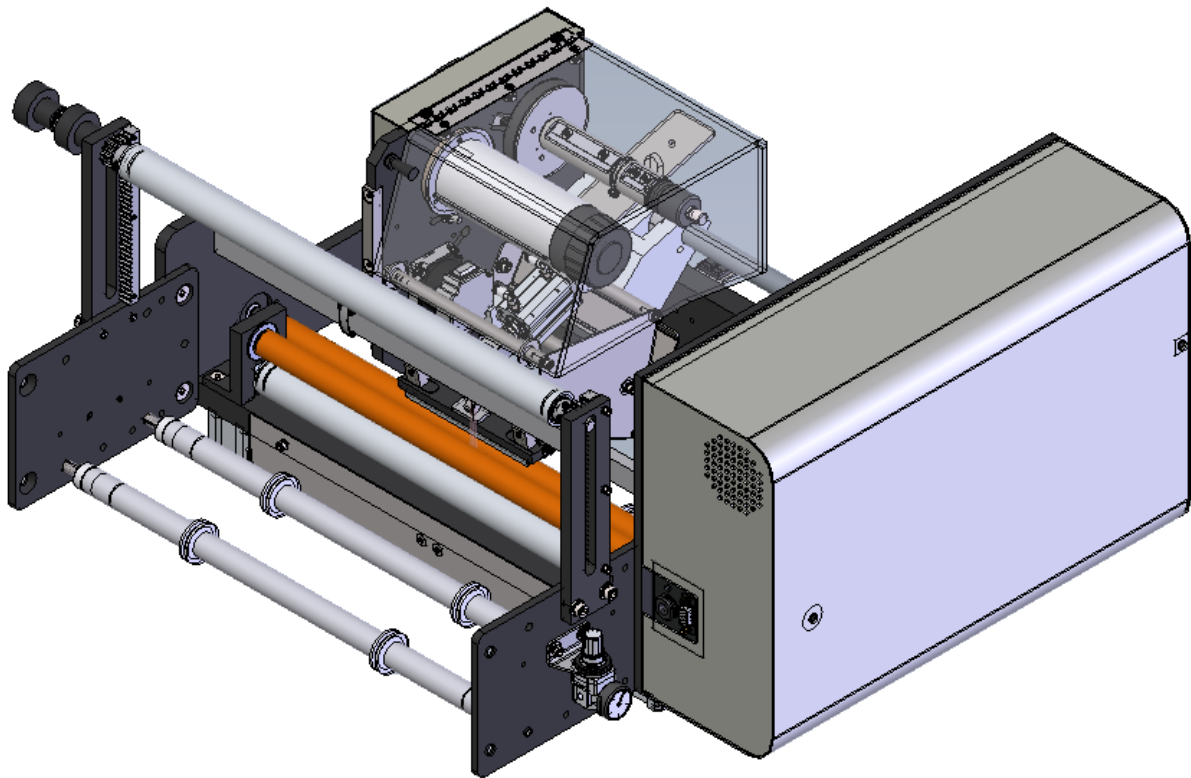

 **Advanced  
Poly-Packaging, Inc.**

1331 Emmitt Road • Akron, OH 44306 • 1-800-754-4403 • fax 330-785-4010 • [www.advancedpoly.com](http://www.advancedpoly.com)

## Acknowledgments

---

Written By: Charles Tolbert, Updated by David Kolinski-Schultz  
Reviewed By: Jeff Heath

## Copyright

---

2019 (Version 1A), 2017 (Version 1) Advanced Poly-Packaging, Inc. (APPI). All rights reserved.

This manual and the program operating the equipment described in it are copyrighted. You may not copy this manual in whole or part without the consent of Advanced Poly-Packaging, Inc.

All information pertaining to the promotion, sale, distribution, operation, and maintenance of the Ti-1000Z including this manual, drawings, schematic, wiring diagrams, video, brochures, specification sheets, figures, charts, or any other information, due to its proprietary design and manufacture remain the property of Advanced Poly Packaging, Inc. Unauthorized duplication, distribution or disclosure to third parties without the express permission of Advanced Poly-Packaging, Inc. is strictly prohibited.

## Trademarks

---

Roll-a-Print is a trademark of Advanced Poly-Packaging, Inc. Advanced Poly-Packaging, Inc. owns also the following trademarks: Advanced Poly-Bags, Advanced Poly-Bagger, Seal-a-Print, Inline Thermal Printer, Twin-Seal, Advanced Poly-Pack, Advanced Poly-Bag, Advanced Bag.

## Limited Warranty and Disclaimer

---

Warranty period is 12 months or 1,000,000 cycles whichever comes first. The warranty commences on the date of delivery of the equipment to the Purchaser. Print head warranty period is 90 days (wear item). APPI warrants to the Purchaser that the equipment is free from defects in workmanship or material under normal use and service. During the warranty period, APPI agrees to repair or replace, at its sole option, without charge to Purchaser, any defective component part of the equipment. To obtain service, Purchaser must return the equipment or component to APPI or an authorized APPI distributor or service representative in an adequate container for shipping. Any shipping charges, insurance, or other fees must be paid by Purchaser and all risk for the equipment shall remain with Purchaser until such time as APPI takes receipt of the equipment. Upon receipt, APPI, the authorized distributor or service representative will promptly repair or replace the defective component and then return the equipment or component to Purchaser, shipping charges, insurance, and additional fees prepaid. APPI may use reconditioned or like new parts or units, at its sole option, when repairing any component or equipment. Repaired products shall carry the same amount of outstanding warranty as from original purchase. Any claim under the warranty must include a dated proof of delivery. In any event, APPI's liability for defective components or equipment is limited to repairing or replacing the components.

This warranty is contingent upon proper use of the equipment by Purchaser and does not cover: expendable component part such as Print Heads, thermocouple wire, heater cartridge, rollers, bushings, and the like; or if damage is due to accident, unusual physical, electrical or electromechanical stress, neglect, misuse, failure of electric power, water damage (from airlines), improper environmental conditions, transportation, tampering with or altering of the equipment, packaging of corrosive or contaminating products or other products damaging to components, and equipment or components not owned or in the possession of original Purchaser. APPI will not be liable for loss of production, profits, lost savings, special, incidental, consequential, indirect or other similar damages arising from breach of warranty, breach of contract, negligence, or their legal action even if APPI or its agent has been advised of the possibility of such damages or for any claim brought against the Purchaser by another party. This warranty allocates risks of equipment failure between Purchaser and APPI. APPI's pricing reflects this allocation of risk and the limitations of liability contained in this warranty. The warranty set forth above is in lieu of all other express warranties, whether oral or written. The agents, employees, distributors, and dealers of APPI are not authorized to make modifications to this warranty, or additional warranties binding on APPI. Accordingly, additional statements such as dealer advertising or presentations, whether oral or written, do not constitute warranties by APPI and should not be relied upon.

Warranty on equipment is considered void when outstanding balances become delinquent (over 30 days late - 60 days after ship date). Equipment Integration to other Equipment: APPI assumes no responsibility for the integration of its products to other products or within a system unless APPI performs the integration, testing and provides the results of the tests to the purchaser in writing. Furthermore, APPI assumes no responsibility for bag sizing whether suggested or recommended.

# TABLE OF CONTENTS

<b>Chapter 1: Introduction</b>	<b>6</b>
1.1 Welcome.....	7
1.2 Overview .....	7
1.3 Special Features.....	7
1.4 Using This Manual .....	8
1.5 Contact Information .....	8
1.6 Warranty Registration .....	9
<b>Chapter 2: Getting Started</b>	<b>10</b>
2.1 Chapter Summary.....	11
2.2 Safety, Risks.....	11
2.3 Installation Procedures .....	12
2.4 Air and Power Requirements .....	12
2.5 Main Power .....	13
2.6 Rear Power Switch .....	13
2.7 Bag Threading.....	13
2.8 Ribbon Threading.....	13
2.9 Cycle Operation of the Printer .....	13
2.10 Adjusting Rear Tension.....	14
2.11 Note on Adjustments to the Printer.....	14
<b>Chapter 3: Touch Screen Operation</b>	<b>18</b>
3.1 Chapter Summary.....	19
3.2 Touch Screen Identification .....	19
3.3 Touch Screen Specifications / Features .....	19
3.4 Touch Screen Program.....	19
3.5 Ti-1000ZR Operation.....	19
3.6 Start up .....	20
3.7 Operation.....	20
3.8 Main Menu .....	20
3.9 Printer Settings .....	20
	2

3.10 Stored Labels.....	22
3.11 Counters .....	22
3.12 Tech Assist .....	23
3.13 APPI Factory .....	23
3.14 Printer Status .....	23
3.15 PLC I/O Status .....	24
3.16 Warning Messages .....	24
<b>Chapter 4: Settings, Adjustments, Maintenance and Troubleshooting</b>	<b>26</b>
<hr/>	
4.1 LabelView Setup Parameters Software Settings.....	27
4.2 ZebraDesigner Driver Settings.....	27
4.3 Adjustments, Maintenance and Troubleshooting.....	27
4.4 Machine Adjustments.....	27
4.5 Tracking and Alignment Adjustments .....	27
4.6 Compression (Nip) Roller Adjustment .....	27
4.7 Idler Roller Guides .....	27
4.8 Machine Maintenance .....	28
4.9 Preventive Maintenance Checklist .....	28
4.10 Scheduled Maintenance Chart (perform every 500,000 cycles) .....	29
4.11 Troubleshooting Guide.....	30
4.12 Troubleshooting Checklist .....	30
4.13 PLC IO Listing.....	31
4.14 Electrical Drawings.....	31
4.14.1 TIZ-E1_110VAC.....	32
4.14.1 TIZR-E2_FPG-IO.....	33
4.14.1 TIZ-E3_AXH_rev1 .....	34
4.14.1 TIZR-E6_ZebraIF.....	35
4.14.1 TIZR-E7_FP0R-GT02.....	36
4.14.1 TIZR-E9_CB IF.....	37
4.14.1 TIZ-E8_AuxIF_rev4.....	38
<b>Chapter 5: Parts and Drawings</b>	<b>40</b>
<hr/>	
5.1 Ti-1000Z Inline Thermal Printer.....	41
5.2 Electronics Assembly.....	42

5.3 Mounting Assembly .....	44
5.4 Nip Roll Assembly .....	46
5.5 Printer Register.....	48
5.6 Zebra Printer Assembly.....	50
5.7 Zebra Printer Assembly, Continued .....	52

This page intentionally left blank.

# Chapter 1: Introduction

---

Welcome

Overview

Special Features

Using This Manual

Contact Information

Warranty Registration

## 1.1 Welcome

Now that you have decided to update your Ti-1000Z Inline Thermal Printer, with Zebra Printer Technology from Advanced Poly-Packaging, Inc., we thank you for selecting our equipment, materials, and service.

## 1.2 Overview

APPI printers are designed to lower your printing costs with high speeds, versatility, reliability, and simplicity.

**High Speeds:** Indexes, opens, seals, and tears off a bag at high speeds. Actual packaging speed depends on bag size, equipment options, product characteristics and loading method.

**Versatility:** Bags virtually any product including fasteners, hardware, injection molded parts, kits, crafts, foods, medical devices and more. Runs bags produced from LDPE, LLDPE, HDPE, Foil, Polypropylene, Tyvek™ and various barrier films.

**Reliability:** Crafted from the highest quality components and materials to withstand the most rigorous manufacturing environment, sturdy mounts and rugged frame guarantee long life and usefulness with minimal maintenance.

**Simplicity:** A user-friendly, menu-driven touch screen program allows operators to set up the bag, options, and auxiliary equipment, save the settings in memory, and recall those settings for repeat runs.

## 1.3 Special Features

**Ribbon Saver:** Ribbon usage is based on the label download size in the software. The print head lowers to print onto the film.

**Energy Conservation and Component Saver:** To extend its life and conserve energy in your plant, the Ti-1000Z, the Ti-1000Z RAP and the T-1000-S14 NBO are programmed to sequentially shut down components when not in use for extended periods of time. A screen saver is provided to extend the life of the touch screen.

**Pass Code Protection:** This feature protects setting screens from alteration by unauthorized individuals. If enabled, a timer causes the pass code screen to be displayed from the Operation screen after a preset period of nonuse. Factory settings are protected by a Level 1 pass code. This pass code should only be provided to authorized maintenance personnel.

**Predetermining Counter:** Preset your printer to stop after a predetermined number of bags have been printed. Set the quantity of finished bags to complete a print job.

**Totalizing Counter:** Reset this counter at the beginning of each shift or day to record printing production over a period of time.

**Next Bag Out Printing:** The T-1000-S14 NBO features a patented method of printing the next bag out. This feature prevents the mislabeling of pharmaceuticals, prescriptions, and other high cost items. The part number and other printing information can be changed for every bag without wasting materials.



**Dual Printing:** Special programming allows the T-1000-S14 to operate with both the Next Bag Out printer and an offline printer in order to print on both sides of the bag. The offline printer is mounted upside down on the back of the bagger.

## 1.4 Using This Manual

This manual describes the features and operation of the Ti-1000Z Inline Thermal Printer. This manual functions as an operation and parts manual for the retro fit Ti-1000Z printer only. See T-1000 manual for information regarding the bagger.

*NOTE: Only the Ti-1000Z and the Ti-1000Z RAP can operate as standalone machines.*

The following manual conventions are frequently used to assist in understanding important information, to alert the operator of potentially dangerous or damaging practices and to describe the normal functions of the Ti-1000Z.

- Text: Normal text
- *Italics:* Used for emphasis
- **Boldface:** Used to identify heading names and touch screen buttons.
- **CAUTION:** Warning messages. To avoid physical harm, damage to equipment or damage to the product, be sure to read these messages carefully.
- *NOTE:* Identifies important information.

## 1.5 Contact Information

To better serve your bagging needs, call **(330) 785-4000** or toll free **1-(800) 754-4403** for convenient service solutions, Monday through Thursday, 9:00 AM to 5:30 PM EST, or Friday 9:00 AM to 5:00 PM EST. For technical assistance with current machinery, ask for **Service**. To order spare parts for your system, ask for **Parts**. To order auxiliary equipment for your current system, ask for **Machine Sales**. To place an order for bags, ask for **Bag Sales**.

You may also contact any of these departments by email:

Reach Service at [Service@advancedpoly.com](mailto:Service@advancedpoly.com)

Reach Parts at [Parts@advancedpoly.com](mailto:Parts@advancedpoly.com)

Reach Machine Sales at [MachineSales@advancedpoly.com](mailto:MachineSales@advancedpoly.com)

Reach Bag Sales at [Bagsales@advancedpoly.com](mailto:Bagsales@advancedpoly.com)

For general inquires: [Sales@advancedpoly.com](mailto:Sales@advancedpoly.com)

Or visit us online at [www.advancedpoly.com](http://www.advancedpoly.com)

In order to provide the best service possible, please have model and serial number ready.

## 1.6 Warranty Registration

This section must be completed and returned to Advanced Poly-Packaging, Inc. to register the printer for Warranty Protection.

Serial Number:

---

(Serial Number located on the back panel)

Company Name and Address

Contact Name(s) / Title(s) / Phone Number

<hr/> <hr/> <hr/>	<hr/> <hr/> <hr/>
-------------------	-------------------

Please email, fax, or mail this page to:

Service Manager  
Advanced Poly-Packaging, Inc.  
1331 Emmitt Road  
Akron, OH 44306  
USA

Fax # (USA) 330-785-4010

Email the information above to: [service@advancedpoly.com](mailto:service@advancedpoly.com)

# Chapter 2: Getting Started

---

Chapter Summary

Safety, Risks

Installation Procedures

Air and Power Requirements

Main Power

Rear Power Switch

Bag Threading

Ribbon Threading

Cycle Operation of the Printer

Adjusting Rear Tension

Note on Adjustments to the Printer

## 2.1 Chapter Summary

This chapter describes procedures to receive and set up the Ti-1000ZR, including safety precautions, uncrating and assembly instructions, environmental, air and power requirements, and height adjustments. Additionally, this chapter describes how to turn on the printers and properly thread film and ribbon.

## 2.2 Safety, Risks

Many safety features have been included in the mechanical, electronic, and pneumatic systems of this machine. Despite these safety precautions, operators may receive lacerations, minor burns, or crushed or broken bone injuries if they come in contact with any moving components. Improper use, improper adjustments and neglect of preventative maintenance may result in serious personal injury. No special personal protective equipment is required to operate the equipment, but eye protection, gloves or other protection should be worn, depending on the characteristics of the product being packaged and the method of loading product.

Please carefully read the following precautions to operate the equipment properly and avoid injury:

- ***CAUTION: Initial setup of the machine must be performed by specialized personnel. Qualified service engineers should uncrate the equipment, assemble the equipment (if required), test and connect power sources, test the equipment for proper operation and otherwise set up the equipment for use.***
- ***CAUTION: Do not attempt to adjust the height without assistance and without supporting the weight of the machine. Attempting to make a height adjustment without assistance could cause the machine to drop suddenly, causing severe injury. APPI offers several optional accessories that can reduce the risk of injury during height adjustments. These accessories include carts, motorized height adjustment components and stabilizing bars.***
- ***CAUTION: Ensure that any height adjustments allow for sufficient movement of the operator. Improper height adjustments could negatively affect operator movement, causing strain, added stress, discomfort and fatigue.***
- ***CAUTION: To avoid injury, do not operate the equipment if funnels, guards, covers or other access panels have been removed. If any of these safety measures have been removed or modified or if any openings have been increased, the operator will have access to moving components and extreme temperatures that can cause crush, cut, or burn injuries to hands or fingers.***
- ***CAUTION: To avoid injury, do not reach under the equipment, guards or elsewhere under the machine. Do not place hands or fingers in the seal area or near the seal bar, heater bar, load shelf or other moving components.***
- ***CAUTION: Do not remove or loosen fasteners on the frame. If loosened, the equipment may drop suddenly, causing injury or damage to the machine.***
- ***CAUTION: Be careful when opening the seal frame as it may drop suddenly, causing injury or damage to the equipment.***
- ***CAUTION: To avoid injury, avoid coming in contact with pinch points including rollers, automatic funnel doors or other moving components.***

- **CAUTION:** To avoid injury, avoid contact with roller “fingers” as they may be sharp.
- **CAUTION:** Exercise care when adjusting or relocating the touch screen. Movement of the touch screen could cause unexpected movement of the machine and injury to the operator.
- **CAUTION:** If control or air pressure settings are set too high, higher noise levels may result from increased part on part contact or part on machinery contact. Limit these settings and add guards or covers to reduce airborne noise.
- **CAUTION:** Exercise extreme care when clearing jams, replacing materials, changing controls or mechanical settings, and cleaning internal parts. Be sure to de-energize energy sources prior to removing guarding. Failure to do so may result in unexpected movement or flying objects, which could cause crush, cut, or eye injuries.
- **CAUTION:** Maintenance must be performed by specialized personnel. Qualified service engineers must remove guards or covers to gain access to electrical or mechanical areas.
- **CAUTION:** Maintenance must be performed regularly to ensure that the machine is operating properly and to protect against injury. Routine maintenance includes: periodic inspections, the replacement of worn or damaged components, the tightening of loose bolts or components, and regular cleaning and adjustments. Contact APPI and/or service centers for service support if there is not sufficient maintenance staff at your facility to perform regular maintenance.

## 2.3 Installation Procedures

The printer is transported completed assembled in a container designed to protect the machine during shipment. If the printer is operating with the T-1000-S14, the printer will be bolted onto the bagger.

After removing the stretch wrapping, remove the carton from the skid, open the top and cut all four corners using a safety knife. Then, transport the machine to the operating location.

**CAUTION:** Do not attempt to lift the machine from the carton without first cutting all sides open. To prevent injury, do not attempt to lift the machine without assistance.

**Operating Environment / Location:** The printer should be placed in an area free of excessive heat, moisture, dirt, and dust. Operating room temperature should range from 50-100° Fahrenheit. (10-37.7° Celcius)

## 2.4 Air and Power Requirements

**Ti-1000Z:** Provision must be made for 110 VAC, 60 Hz line current with ground. Optional 220 VAC / 50 Hz voltage may have been supplied based on your local electrical requirements. The full load current for the Ti-1000Z is 5 Amps.

**NOTE:** APPI recommends a dedicated 15 Amp circuit for the Ti-1000Z

**CAUTION:** A qualified electrician should ensure that the machine’s power outlet is properly grounded, voltages are as required and amperage capacity is sufficient.

**Ti-1000Z:** At least 0.5 CFM free air is required, regulated from 25 to 60 PSI (1.72 to 4.13 Bar), to obtain the best print quality and drive roller compression.

An air regulator is provided to adjust the pressure to the print head assembly. This regulator should be set from 35 to 50 PSI (2.41 to 3.45 Bar) to obtain the best print quality. A separate air regulator is provided to adjust the pressure to the compression rollers. The pressure should be sufficient to drive the film, but not high enough to cause the film to wrinkle. This regulator should be set from 20 to 30 PSI. (1.38 to 2.07 Bar)

An air-line supply should be fed to the Ti-1000Z with 3/8" (0.95 cm) ID flexible tubing. This tubing affixes to the coupler adapter (quick disconnect not provided). Connect the air to the regulator by holding the regulator firmly in one hand and pushing the air line connector on the male regulator connector. Insert the Ti-1000Z power cord into an 110VAC, 60Hz, grounded power outlet.

## 2.5 Main Power

If your printer is operating with the T-1000-S14, the main power switch that turns on both machines is located on the bagger's side cover. To turn the machines on, turn the switch from its vertical OFF position to its horizontal ON position. If you wish to turn on the printer only or if your printer is operating as a standalone machine or with a bagger other than the T-1000-S14, the printer's main power switch is located on the rear panel of the printer electronics box. To turn the machine on, press the red **Printer Power** switch.

When the machine(s) is turned on, the green Power light on the touch screen will illuminate and the Introduction screen will be displayed. The program version will also be identified. The Introduction screen will only appear for a few seconds until automatically changing to the Operation screen or Main Menu.

## 2.6 Rear Power Switch

The Rear Power Switch is located in the back of the machine and is used to turn on the power to the printer only, without affecting the PLC function. The power is separated to allow the printer to be reset, which will also clear the memory of the printer, or errors.

## 2.7 Bag Threading

Refer to Figures 2-1 and 2-2 for proper bag / film threading of the Ti-1000Z and Ti-1000Z RAP, respectively. Alternate threading may be required based on your bagger. Refer to your bagger's operation guide for additional information.

## 2.8 Ribbon Threading

Refer to Figure 2-6 for proper ribbon threading of the Ti-1000Z. The print head assembly can be rotated up and back for easy ribbon changes. Release the locking mechanism and raise the print head assembly.

***CAUTION: To avoid injury or damage to the print head, do not release the print head assembly. Lower the assembly carefully into position and lock the mechanism before operating the printer.***

## 2.9 Cycle Operation of the Printer

If all prior installation procedures were performed properly, the printer should be in its operating location with air and power connected. All covers should be in position and securely fastened.

*NOTE: The web of bags may track right or left for a few feet until “settled” on the web path. The roll of bags or the roller guide may require readjustments or realignment after the first few feet of bags are indexed.*

To test cycle the printer with a test label that has been downloaded from APPI, load Label 001 from the Stored Labels screen (if the printer is operating as a standalone machine) or from the printer’s Setup screen (if the printer is operating with the T-1000-S14). To load this label, press the **Label #** button, enter “001” and press the **ENT** button. Then, while in Setup mode, press the **Manual Cycle (MC)** button. This procedure will cause the compression (nip) roller to clamp onto the film. Then, the print head will lower and the nip rollers will pull the film through the print head while printing. Label 001 has graphics, small print and a line that provides a good test for print quality.

## 2.10 Adjusting Rear Tension

The printer is not designed to cause heavy rolls to unwind. Heavy rolls may require a driven unwind stand and dancer system. If the film cannot properly feed through the nip rollers, first try to increase, or decrease the nip pressure by adjusting the air pressure. If the film does not feed properly through the nip rollers, increase, or decrease film tension (rear tension).

## 2.11 Note on Adjustments to the Printer

Upon receipt, it is not unusual for the print head to be out of alignment due to shipping and excessive handling. Unless physically damaged, the printer will function properly after minor adjustments are made.

## Ti-1000Z THREADING DIAGRAM

Figure 2-1

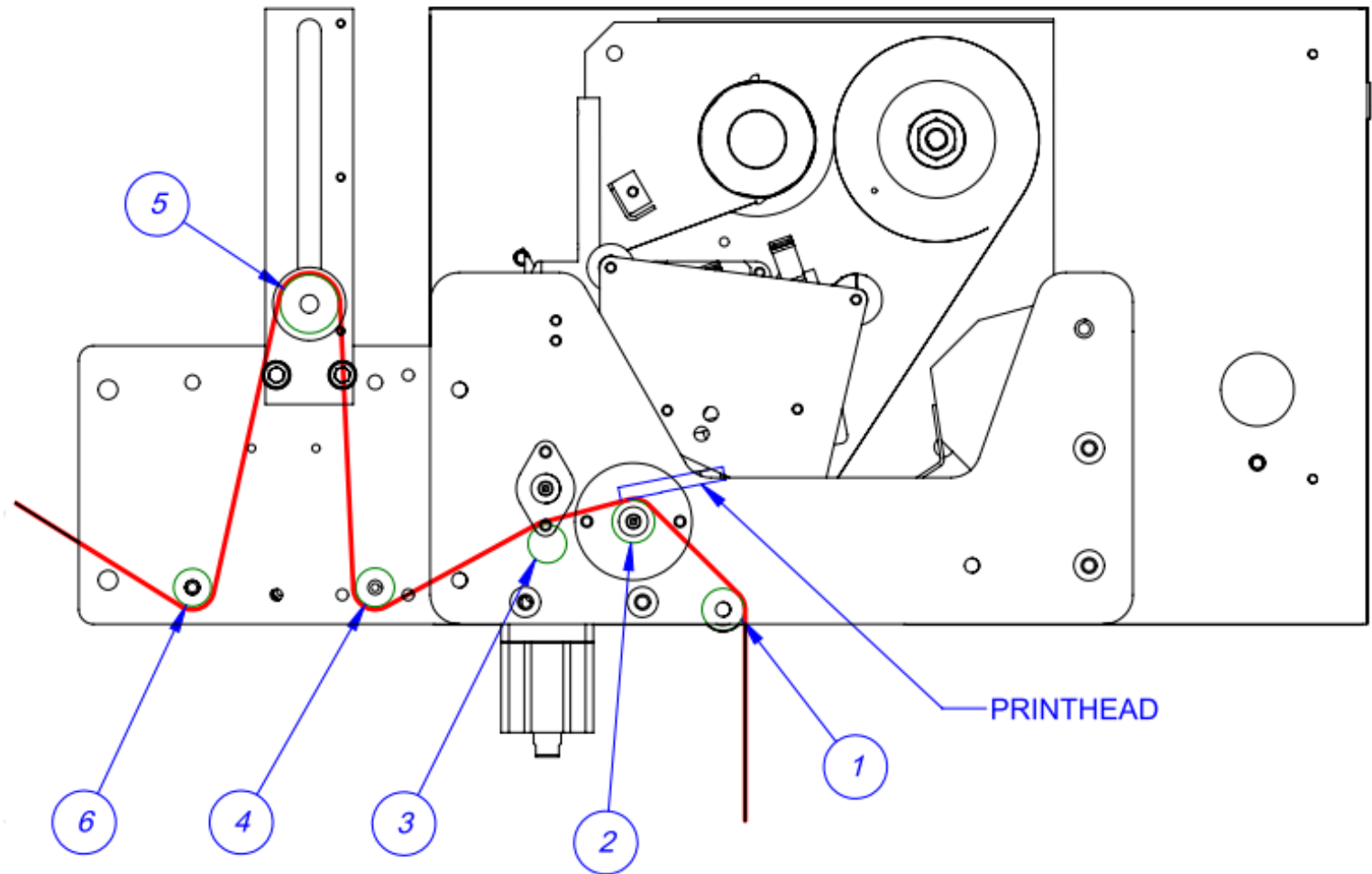



# Ti-1000Z WITH T-1000-S14 THREADING DIAGRAM

SINGLE DANCER

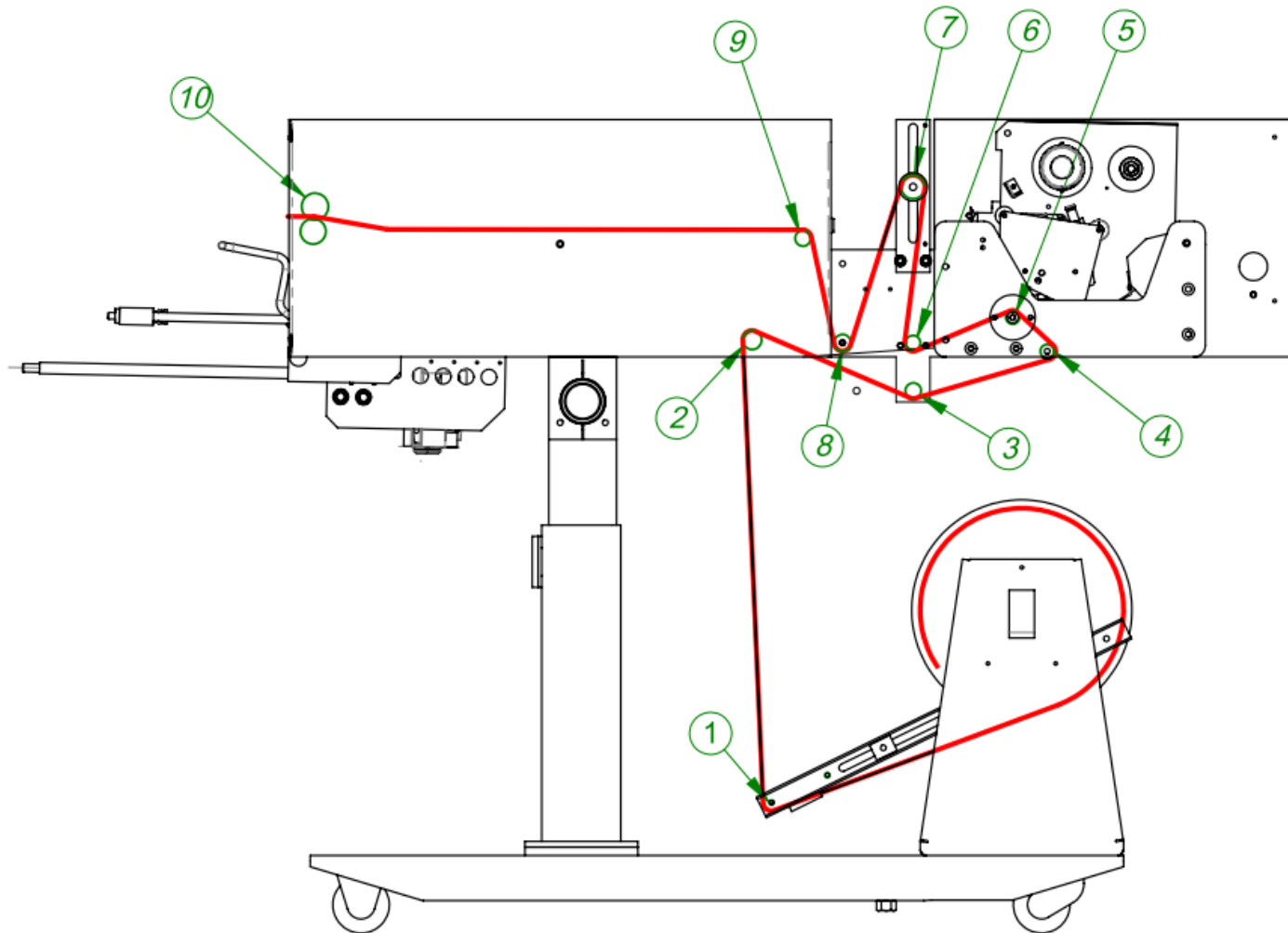

Figure 2-2

## Ti-1000Z RIBBON THREADING DIAGRAM

---

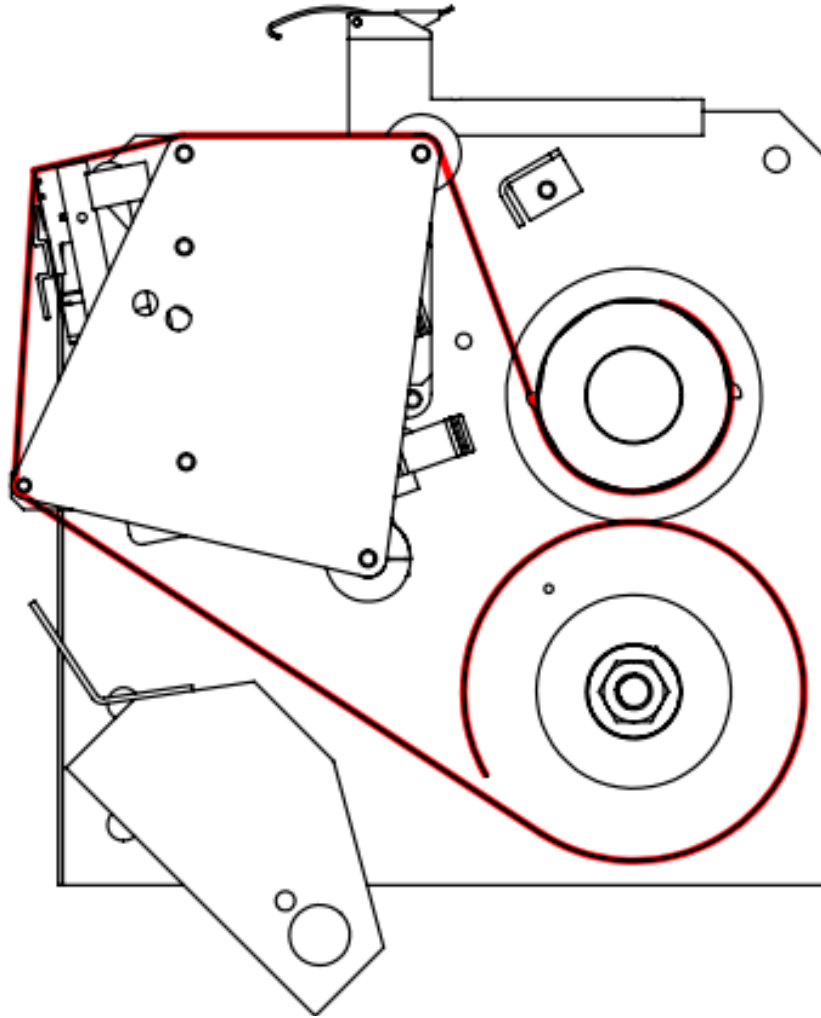

Figure 2-3

# Chapter 3: Touch Screen Operation

---

Chapter Summary

Touch Screen Identification

Touch Screen Specifications / Features

Touch Screen Program

Ti-1000ZR Operation

Start up

Operation

Main Menu

Printer Settings

Stored Labels

Counters

Tech Assist

APPI Factory

Printer Status

PLC I/O Status

Warning Messages

### 3.1 Chapter Summary

This chapter describes the identification, operation, and settings of the touch screen program for the Retro Fit Ti-1000Z printers. This section is focused on the setup and operation of the printer through a small 3” color touch screen.

### 3.2 Touch Screen Identification

BACK PANEL:

- RS-232 Communication port to PLC
- Programming (For APPI use only)
- Power Supply: Power terminal for touch screen operation.

**CAUTION:** Do not attempt to reprogram the PLC or touch screen. Doing so may cause an unsafe operating condition and void the warranty. Additionally, do not change the DIP switch settings.

### 3.3 Touch Screen Specifications / Features

Specifications	
Screen Resolution	3” 128 x 64 pixels
LCD	Green, Red, Orange
Memory	384 Kb
Communication	RS232C
Touch Key Res.	Free, Analog
Languages	English, Spanish, French, German, Italian, Japanese, Chinese, Korean
Dimension	110 x 72 x 28 mm (W x H x D)
Back Light	No Backlight
Power Supply	5Vdc, 0.20A

### 3.4 Touch Screen Program

The touch screen program is a “user-friendly”, menu-driven setup and operation program. Popup windows are incorporated for quick and easy setting adjustments. Each time a setting is changed, the settings are saved so that if power is lost, the “job” will be recalled automatically without the need for reprogramming. A general color scheme is used for operation consistency and to identify functions:

- **Black:** Text information, borders.
- **Green:** General background of the touch screen environment.
- **Red:** Indicates a error, warning

### 3.5 Ti-1000ZR Operation

If you purchased the Ti-1000Z with the T-1000-S14 Advanced Poly-Bagger, please refer to the following sections for information about the printer’s operation.

The T-1000-S14 touch screen program controls the operation of the Ti-1000Z, an offline printer mounted behind the bagger. To access operation, settings, and status screens specific to Ti-1000Z, press the **TI1000Z** button on the Bagger Options Menu. Refer to the T-1000-S14 Operation Guide for information about the bagger’s program.

### 3.6 Start up

When the printer is first turned on, a screen will pop up for only a few seconds before changing to the operation screen.

This screen displays your equipment type, HMI program and PLC program. It's important to note this information if you ever lose your program due to a loss of power to the PLC.

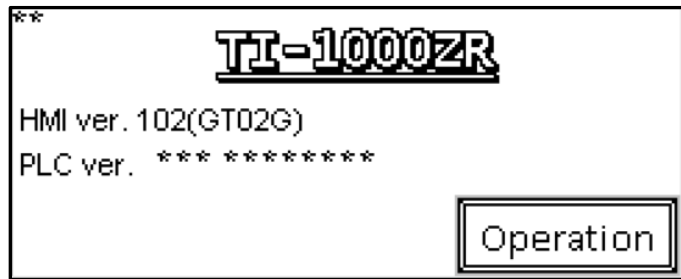

Figure 3-1

### 3.7 Operation

After the startup screen disappears, the operation screen will show. This screen will just display a quick status of the printer.

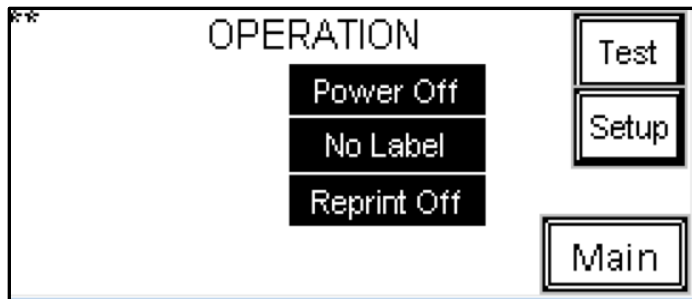

Figure 3-2

### 3.8 Main Menu

This screen is used for navigating the program. Many settings and options can be accessed through this interface.

**Operation:** Takes you to the operation screen.

**Settings:** Make changes to the printer's functionality

**Labels:** To load labels into the printer. Either from stored or labels created on an approved software.

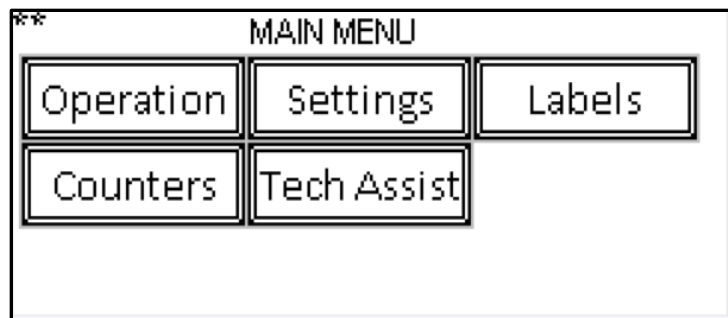

Figure 3-3

**Counters:** View total cycles the printer has ran, cycles during a production shift and hours the printer has been on.

**Tech Assist:** Troubleshoot issues with the printer. View I/O

### 3.9 Printer Settings

The Printer Settings screen displays the printer's status and label parameters. It also allows for adjustment of the stored label settings. Refer to Figure 3-3 (above). This screen is accessed by pressing the <settings> button on the Main Menu.

Press the **ON / OFF** toggle button to turn the printer on and off. To manually cycle one bag through the printer, press the **Test** button.

Settings can only be adjusted while the printer is in **Setup** mode. An error will be displayed on the baggers touch screen. After adjustments and test are complete, return the printer to **run** mode by pressing <setup>. Do the same to take the printer out of **run** mode.

The Printer Settings screen features rectangular indicators that display the printer's status:

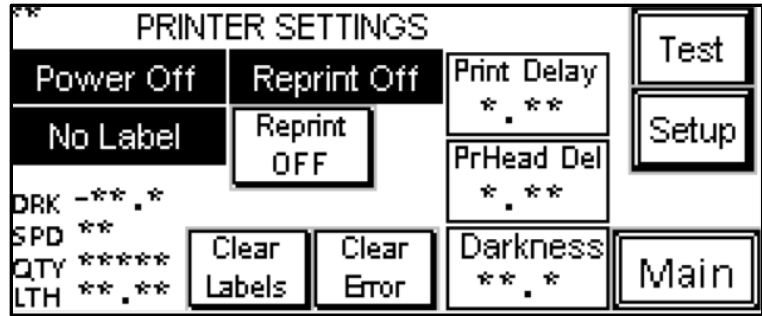

Figure 3-4

- **Power OFF** indicates that the printer is off. This box will also display “Self-Test” when the printer is first turned on and “Ready” during startup if an error does not exist.
- **No Label / Label** indicates whether or not a label has been downloaded. This box will also display “Error,” “Printing” and “No Ribbon” during various stages of operation.
- **ReprintBuffer**: If “ReprintBuffer” is displayed, the printer is continuously printing a preset amount of the same label. If “ReprintBuffer” is displayed in grey, the reprint function is not activated. If “New Label” is displayed, a new label has been downloaded. If “StoredLabel” is displayed, a label has been recalled from stored memory.

The second column on the Printer Setup screen serves as a further indicator of the printer's status. This box will display **Reprint OFF**, if the reprint function has been turned off, **Reprint ON** if the reprint function has been turned on and **OverWrite** if previous label settings are overridden.

This screen also displays the downloaded label parameters, including the **Darkness** setting, the **Speed** setting, the **Quantity** setting and the **Length** setting. The Darkness, Print Speed, Quantity and Length parameters are set up in the label software. They are displayed on the OFL Printer Setup screen for informational purposes. However, the Darkness and Length settings can be changed on this screen.

**Print Delay**: This setting causes the nip rollers to compress first, thus delaying the print head from lowering. This will ensure that the film is captured and ready to start feeding before the print head lowers. Increasing this delay time will cause loss of production. To change this setting, press the **Print Delay** button, enter a value on the numeric keypad and press the **ENT** button.

**PrHead Del**: This setting is the amount of time, in seconds, before the machine cycles again after completing the previous cycle. To change this setting, press the **PrHead Del** button, enter a value into the numeric keypad and press the **ENT** button.

**Darkness**: Darkness can be set between 1 and 30. Darkness settings can be set in your label software, but can also be overridden by adjusting the Darkness setting on the OFL Printer Setup screen. Increase the Darkness setting to improve print quality. A typical setting is 20. To change this setting, press the **Darkness** button, enter a value into the numeric keypad and press the **ENT** button.

The **Stored Label** button will expand the options to include **Label #** and **Length**.

### 3.10 Stored Labels

**Label #:** This button allows the operator to recall a label. To recall a label, press the **Label#** button and type in a number from 001 to 999, depending on the label you would like to recall. Enter the desired label number into the numeric keypad and press the **ENT** button. From the factory, APPI has included at least one sample label format (001) for testing.

**Length:** This setting allows the operator to adjust the label length. Because the length of the label is not saved when downloading labels in memory, APPI recommends that stored labels are the same length. Otherwise, you must use a chart that describes the label format length for each stored label. To change this setting, press the **Length** button, enter a value into the numeric keypad and press the **ENT** button.

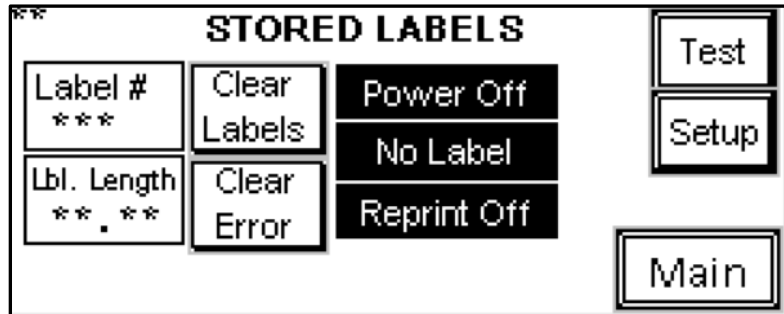

Figure 3-5

The **Clear Labels** button can clear the downloaded label format or the label format that is recalled from stored memory. However, if data records are downloaded from a database, this button will not erase stored labels unless there are less than 90 records remaining. Press the **Clear Error** button to clear an error with the printer and continue operation.

*NOTE: APPI resells several software packages including: Labelview, Zebra Design Pro and Bartender. If you are using other software, APPI may not be familiar with the specific settings available in your software. Refer to your software manual for print speed and darkness settings.*

### 3.11 Counters

**Total:** displays how many cycles between resets. Only total can be reset.

**Maintenance:** Displays the amount of cycles the printer has ran. This cannot be reset.

**Hours:** Displays the amount of time the machine has been turned on and operating.

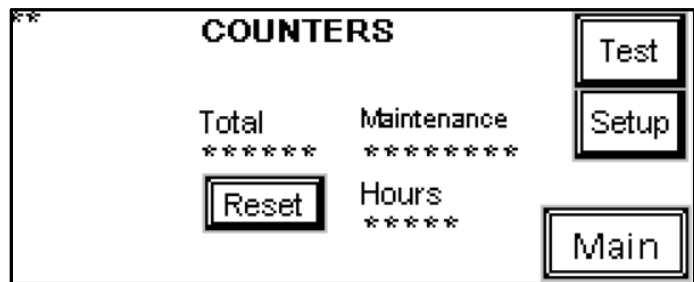

Figure 3-6

### 3.12 Tech Assist

Several screens are available to view under tech assist to help the operator trouble shoot a machine and change critical printer settings. This screen should only be accessed by experienced personnel and APPI service.



Figure 3-7

**APPI:** Press to change between Xi3/Xi4, 200/300dpi and APPI?

**Factory:** View the printer’s status, networks, and configurations. **PLC Info:** View PLC I/O, status of I/O and descriptions of each I/O.

### 3.13 APPI Factory

Pressing Xi4/Xi3 will toggle the button to change between the two. These settings should match the hardware your machine has on it.



Figure 3-8

### 3.14 Printer Status

The printer sends a status message when turned on and after each print. If an error occurs, the actual error message will be displayed on the Printer Status Screen. To reset the status, press the **Clear Status** button. To recall the status, press the **Read Status** button.

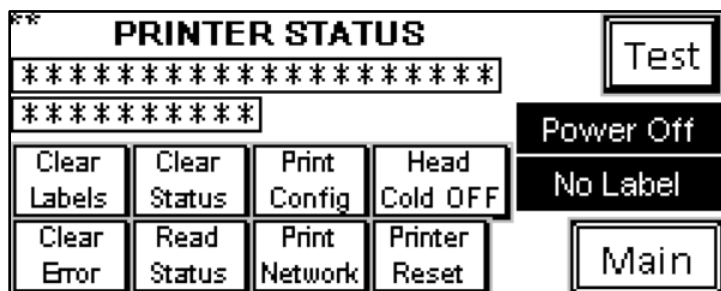

Figure 3-9

**Print Config:** Press this button to print the parameters for the printer onto the bag (i.e. Darkness, Speed).

**Print Network:** Press this button to print the network configuration, including the current IP address onto a bag.

**Printer Reset button:** Press this button to clear labels and start a self-test. This is similar to restarting a computer.

The Head Cold **ON / OFF** toggle button allows the operator to turn the Head Cold Warning feature on and off. If the Head Cold Warning feature is on, the machine will automatically stop if the print head gets too cold.



### 3.15 PLC I/O Status

This screen allows the operator or service personnel to view the currently active inputs or outputs.

Press <info> to view the descriptions for I/O port.

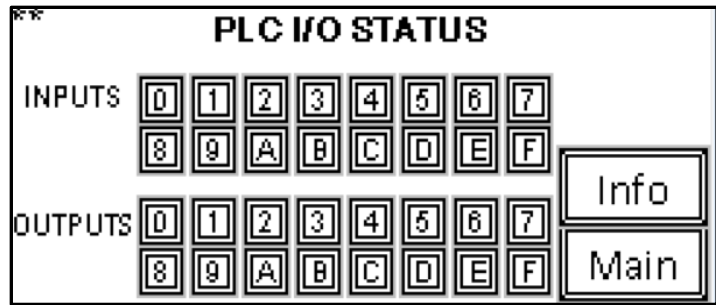

Figure 3-10

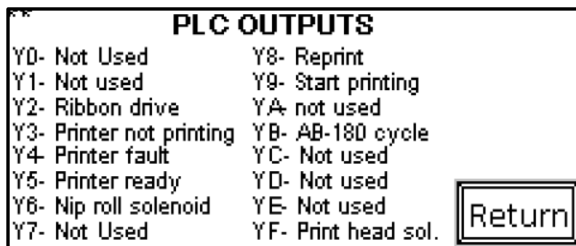

Figure 3-11

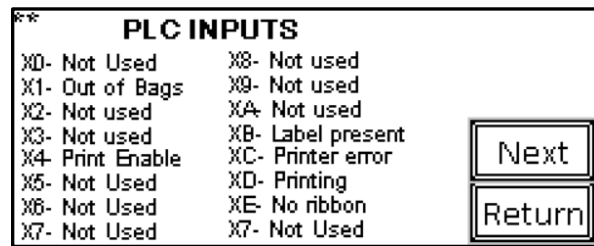

Figure 3-12

### 3.16 Warning Messages

Various warnings and errors will pop up to get the operators attention that something needs to be corrected to continue operation. Descriptions of the action to take will be displayed with the pop-up.

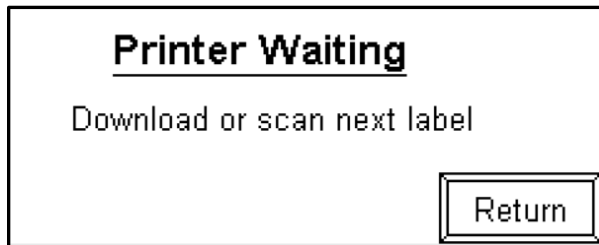

Figure 3-13

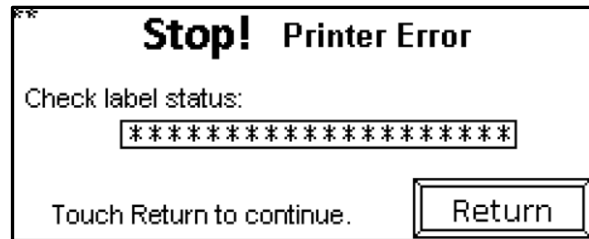

Figure 3-14

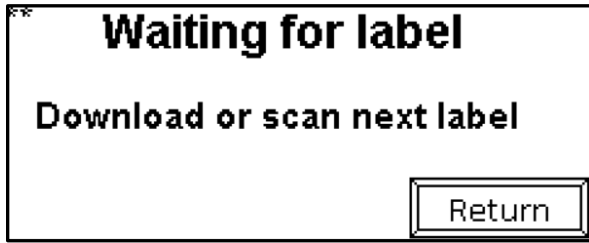

Figure 3-15

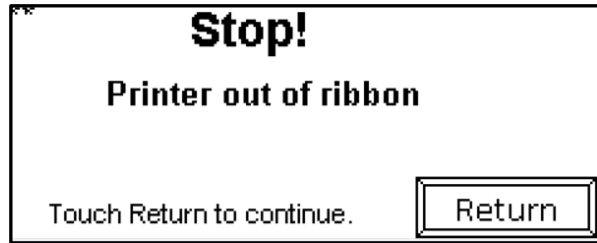

Figure 3-16

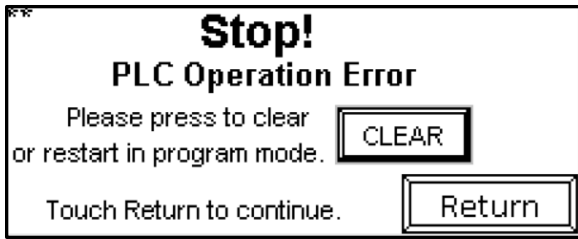

Figure 3-17



Figure 3-18

# Chapter 4: Settings, Adjustments, Maintenance and Troubleshooting

---

LabelView Setup Parameters Software Settings

ZebraDesigner Driver Settings

Adjustments, Maintenance and Troubleshooting

Machine Adjustments

Tracking and Alignment Adjustments

Compression (Nip) Roller Adjustment

Idler Roller Guides

Machine Maintenance

Preventive Maintenance Checklist

Scheduled Maintenance Chart (perform every 500,000 cycles)

Troubleshooting Guide

Troubleshooting Checklist

PLC IO Listing

Electrical Drawings

## 4.1 LabelView Setup Parameters Software Settings

APPI machines that are equipped with the Xi4 driver, including the Ti-1000Z, Ti-1000Z RAP, and T-1000-S14 NBO, have LabelView software available to setup parameters for labels. The screens may change, or information in the parameter settings may change, based on the software version. Please refer to the LabelView Pro addendum for further instruction.

## 4.2 ZebraDesigner Driver Settings

The ZebraDesigner is a label design software which can be included with the Designer Pro Version of the Zebra software. This setup applies to APPI machines equipped with the Xi4 driver, including the Ti-1000Z, Ti-1000Z RAP and the T-1000-S14 NBO. Please refer to the addendum for further instruction.

## 4.3 Adjustments, Maintenance and Troubleshooting

If you purchased the Ti-1000Z or the Ti-1000Z RAP, please refer to the following sections for adjustments, maintenance and troubleshooting information. If you purchased the T-1000-S14 NBO, please refer to the T-1000-S14 Operation Guide for specific instructions.

## 4.4 Machine Adjustments

Periodically, the Ti-1000Z / Ti-1000Z RAP will require readjustment or realignment of components to ensure proper operation. Adjustments may be required after transportation, excessive handling or due to normal wear and tear.

***CAUTION: Machine adjustments, electrical troubleshooting and component replacement should be performed by qualified maintenance technicians, familiar with safety practices including but not limited to equipment lock-out/tag-out, voltages and pneumatics. If you are not familiar with the equipment or have not received training on the Ti-1000Z / Ti-1000Z RAP, you should consult with APPI technical support before attempting adjustments or repairs.***

## 4.5 Tracking and Alignment Adjustments

Tracking problems can cause the thermally printed information to be out of the proper location. To avoid printing problems, machine adjustments to correct the tracking and alignment of the web of bags may be required.

However, before considering adjustment, ensure there is sufficient tension on the film / bag web. When feeding or stopping, the bag roll should not spin freely or feed excess film.

## 4.6 Compression (Nip) Roller Adjustment

The drive roll compression is the force that exists between the two feed rolls (rubber covered grooved roll and grooved steel roll). Too much drive roll compression will cause extra wear on the drive roll and the motor. Adjust the regulator pressure to adjust the nip roller tension. Pressure should be set as low as possible to cause the film to pull the film through the print head evenly without wrinkling.

## 4.7 Idler Roller Guides

Two plastic web guides are located on the rear idler roller. These guides are used for *fine* adjustment of tracking. Once the web is tracking within +/- 1/8" (3.175 cm) left to right, the plastic web guides can be used to further assist tracking. Hold the upper roller in place while turning and sliding the plastic guides close to the bags without touching the bags.

*NOTE: If the bags are not tracking properly, the plastic guides could cause the bag web to turn or fold over. If this occurs, slide the guides further away from the web and make adjustments to correct tracking issues*

## 4.8 Machine Maintenance

To extend the life of the Ti-1000Z / Ti-1000Z RAP, qualified maintenance personnel must perform all required maintenance tasks. Failure to perform scheduled and preventive maintenance may cause excessive wear to components and will void the warranty. This section covers two types of machine maintenance: preventative and scheduled.

For the purpose of this manual, preventive maintenance (PM) tasks are considered periodic tasks that should be performed on a daily, weekly, or monthly basis. Scheduled maintenance tasks are performed when the Ti-1000Z / Ti-1000Z RAP Maintenance Chart Number changes to a higher number. Scheduled maintenance tasks (CHART items) are performed depending on the number of machine cycles and therefore are not considered “periodic” tasks.

**CAUTION: Unplug the power cord and disconnect the air-line prior to removing guards, funnels, or covers. Preventive maintenance must be performed by qualified maintenance personnel.**

## 4.9 Preventive Maintenance Checklist

Item	Description	Period
Filter / Air regulator	Drain water from filter	D
Air regulator	Adjust pressure to required/tested settings (varies)	D
Drive rollers	Clean with alcohol	D
Perforation sensor	Clean sensor assembly with alcohol	D
Platen print roller	Inspect for nicks or cuts, clean with alcohol	D
Print head	Clean with alcohol (also after each ribbon change)	D
Micron filter / Venturi	Inspect for contamination of filter, replace as needed Inspect for blockage / air restriction	W
Wiring / Connectors	Inspect for loose wiring / connectors, tighten as needed	M
Air lines / Valves / Cylinders	Inspect for loose air lines, listen for leaks, tighten, or replace poly tubing as needed	M
Compartments / Covers	Remove all covers, clean, and blow out compartments with compressed air to remove dust and dirt	M
Compression (drive rollers)	Inspect to ensure parallel w/ each other (bag tracking)	M
Drive belt	Inspect for wear / fraying, replace if needed	M
Drive Belt (print head assembly)	Inspect for wear, looseness, tighten as required	M
Head Down Cam	Apply a small amount of grease on both sides of the Head Down Cam and on both sides of the Clevis to prevent them from binding. Apply a small amount of grease between the Head Down Shaft and the Head Down Cam to keep the Cam from binding. Apply a small amount of grease to the front of the Head Down Cam to prevent wear on the back of the print head plate.	M

LEGEND: 

D = Daily	W = Weekly	M = Monthly
-----------	------------	-------------

**CAUTION: Unplug the power cord and disconnect the air-line prior to removing guards, funnels, or covers. Preventative maintenance must be performed by qualified maintenance personnel.**

#### 4.10 Scheduled Maintenance Chart (perform every 500,000 cycles) CHART

Item	Description	1	2	3	4	5	6	7	8	9	10
Drive belt (left panel)	Adjust/Inspect for wear, replace when necessary.	O	O	O	O	O	O	O	O	O	O
Guide rollers	Inspect for free movement	O	O	O	O	O	O	O	O	O	O
Roller bearings	Inspect for free movement	O	O	O	O	O	O	O	O	O	O
Perf sensor and spring	Inspect for wear, replace if required.	O	O	O	O	O	O	O	O	O	O
Rubber drive roll	Inspect for cuts, unevenness	O	O	O	O	O	O	O	O	O	O
Steel upper roll	Clean w/ alcohol, inspect for burs	O	O	O	O	O	O	O	O	O	O
Printed circuit boards / wiring	Blow off with clean, dry air, inspect for loose wires, connectors	O	O	O	O	O	O	O	O	O	O
Cylinders	Listen for air leakage, replace or repair as required	O	O	O	O	O	O	O	O	O	O
Air blower filter	Inspect for contamination, replace as necessary	O	O	O	O	O	O	O	O	O	O
Air lines and connectors	Inspect for wear, cuts, leaking, replace as required	O	O	O	O	O	O	O	O	O	O
Print platen roller	Inspect for free movement, inspect for wear, replace roller or bearings as required.	O	O	O	O	O	O	O	O	O	O
Print head belt	Inspect for tightness and wear, tighten, or replace as required.	O	O	O	O	O	O	O	O	O	O
Print head	Clean, inspect for wear, inspect print quality (missing pixels), replace as required.	O	O	O	O	O	O	O	O	O	O
	INITIALS										

## 4.11 Troubleshooting Guide

The items included in this section cover the common causes of trouble that an operator might encounter during the operation of the Ti-1000Z / Ti-1000Z RAP. When operating difficulties occur, the best procedure is to observe what is happening and attempt to isolate the problem. Make only one adjustment at a time, checking the results of each adjustment. If an adjustment does not help or escalates the problems, return the settings back to the former position.

**CAUTION:** *These tests and repairs should be performed by qualified mechanics or electricians.*

## 4.12 Troubleshooting Checklist

Problem	Cause	Action
Touch screen does not display	<ol style="list-style-type: none"> <li>1. Screen saver is active</li> <li>2. Power off</li> <li>3. Loose connection</li> <li>4. Fuse blown</li> <li>5. Cable shorted / failed</li> </ol>	<ol style="list-style-type: none"> <li>1. Touch the screen</li> <li>2. Plug in power cord / turn on</li> <li>3. Tighten connections</li> <li>4. Replace fuse(s)</li> <li>5. Replace cable</li> </ol>
No main power light	<ol style="list-style-type: none"> <li>1. Blown fuse</li> <li>2. Bulb out</li> </ol>	<ol style="list-style-type: none"> <li>1. Replace fuse</li> <li>2. Replace bulb</li> </ol>
Two bags index from rollers	<ol style="list-style-type: none"> <li>1. Bag is folded over</li> <li>2. Perf sensor dirty / damaged</li> <li>3. Perf sensitivity out of adjustment</li> <li>4. Ungrounded perf sensor circuit</li> <li>5. Seal point value too high</li> <li>6. Feed distance too high</li> <li>7. Zero perf function incorrectly set</li> </ol>	<ol style="list-style-type: none"> <li>1. Straighten bag, thread bags again</li> <li>2. Clean / replace perf sensor</li> <li>3. Adjust pot on High Voltage PCB</li> <li>4. Attach grounding rod to roller</li> <li>5. Change seal point setting</li> <li>6. Set value to zero</li> <li>7. Reset Zero Perf.</li> </ol>
Bag does not completely index	<ol style="list-style-type: none"> <li>1. Perf is sensing hole in bag (vent)</li> <li>2. Seal position setting too low</li> <li>3. Zero perf function incorrectly set</li> </ol>	<ol style="list-style-type: none"> <li>1. Reposition bag left or right</li> <li>2. Increase seal position setting</li> <li>3. Reset Zero Perf.</li> </ol>
First bag after threading indexing multiple bags	<ol style="list-style-type: none"> <li>1. Thread bags not at proper seal position</li> <li>2. Perf Sensor not sensing bag</li> <li>3. Dirty / damaged sensor</li> <li>4. Pot on High Voltage PCB out of adjustment</li> </ol>	<ol style="list-style-type: none"> <li>1. Pull bags through pinch rollers to proper seal point, then cycle machine again.</li> <li>2. Clean / replace sensor</li> <li>3. Clean / replace sensor</li> <li>4. Adjust Pot</li> </ol>
Bags web breaking prematurely in machine	<ol style="list-style-type: none"> <li>1. Improper web tension</li> <li>2. Index speed too high</li> <li>3. Improper threading / web contact</li> <li>4. Bag roll side-plates bent inward</li> </ol>	<ol style="list-style-type: none"> <li>1. Adjust tension</li> <li>2. Reduce speed setting</li> <li>3. Rethread / remove obstructions</li> <li>4. Repair / remove side-plates</li> </ol>

### 4.13 PLC IO Listing

The Main PLC and Expansion PLC IO Listings are provided to assist in troubleshooting the Ti-1000Z and Ti-1000Z RAP. Refer to the T-1000-S14 Operation Guide for the PLC IO Listing for printers operating with the T-1000-S14.

Main PLC				
	Input	Description	Output	Description
	X0	NOT USED	Y0	Not Used
	X1	Out of Bags Sensor	Y1	Not Used
	X2	NOT USED	Y2	Ribbon Drive Enable
	X3	Perf Sensor	Y3	Auxiliary Printer Busy
	X4	INL Print Request	Y4	Auxiliary Printer Fault
	X5	Spare	Y5	Auxiliary Printer Ready
	X6	Spare	Y6	Nip Roll Solenoid
	X7	Spare	Y7	Spare
	X8	RAP: Accum. Empty - Bagger Stop (Top)	Y8	Reprint - Zebra
	X9	RAP: Accum. Full - Print Suspend (Bottom)	Y9	Start Print - Zebra
	XA	Spare	YA	Pause Toggle - Zebra
	XB	Label Ready - Zebra	YB	AB180 Cycle
	XC	Printer Error - Zebra	YC	Spare
	XD	End Print (Printing) - Zebra	YD	Not Used
	XE	Ribbon Out - Zebra	YE	Spare
	XF	Foot Switch	YF	Print Head Down Solenoid

### 4.14 Electrical Drawings

Electrical drawings are provided at the end of this chapter to assist in troubleshooting the Ti-1000Z Inline Thermal Printer.



### 4.14.1 TIZ-E1\_110VAC

#### Electrical Drawing

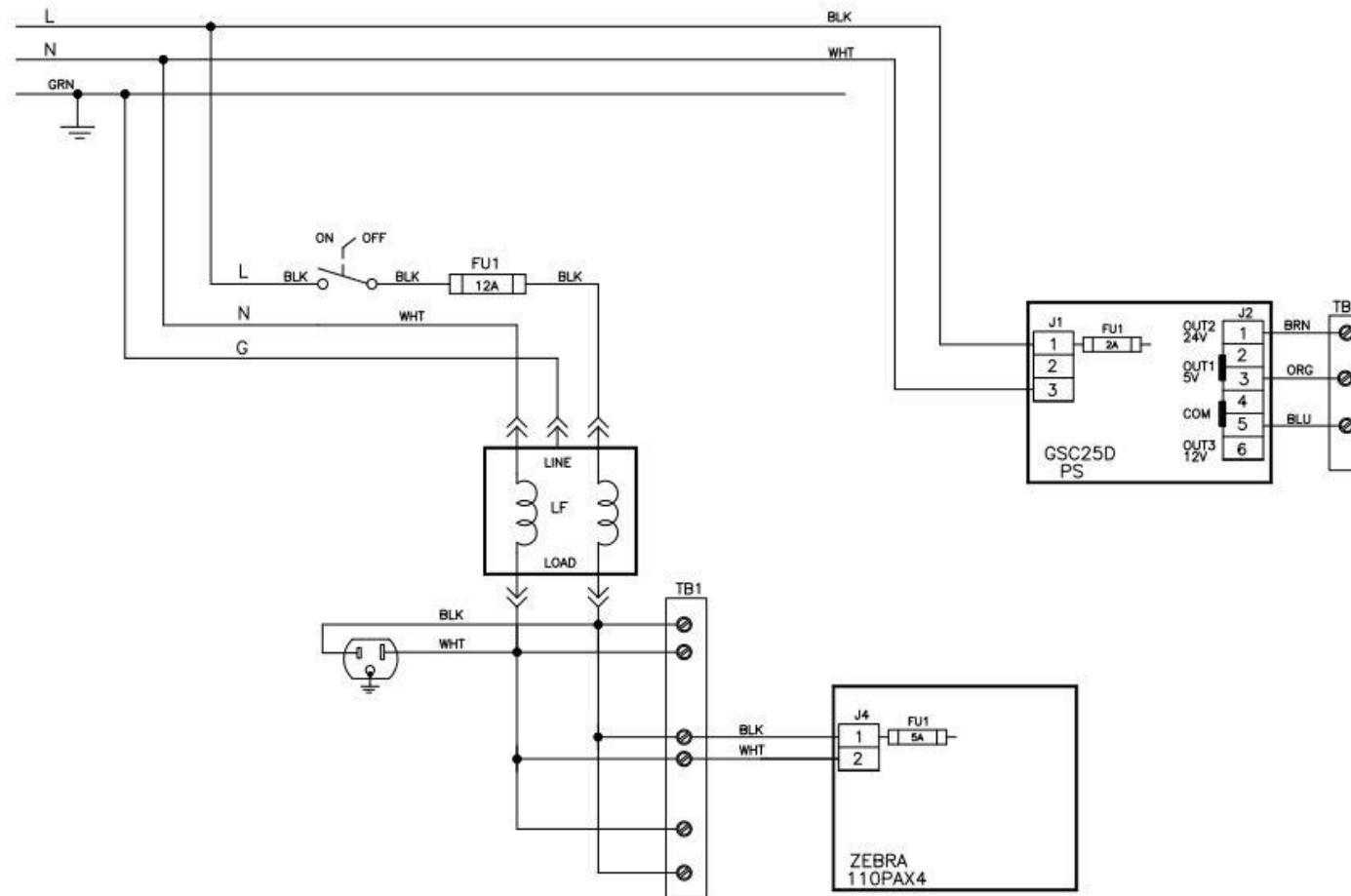

Figure 4-1

### 4.14.1 TIZR-E2\_FPG-IO

#### Electrical Drawing

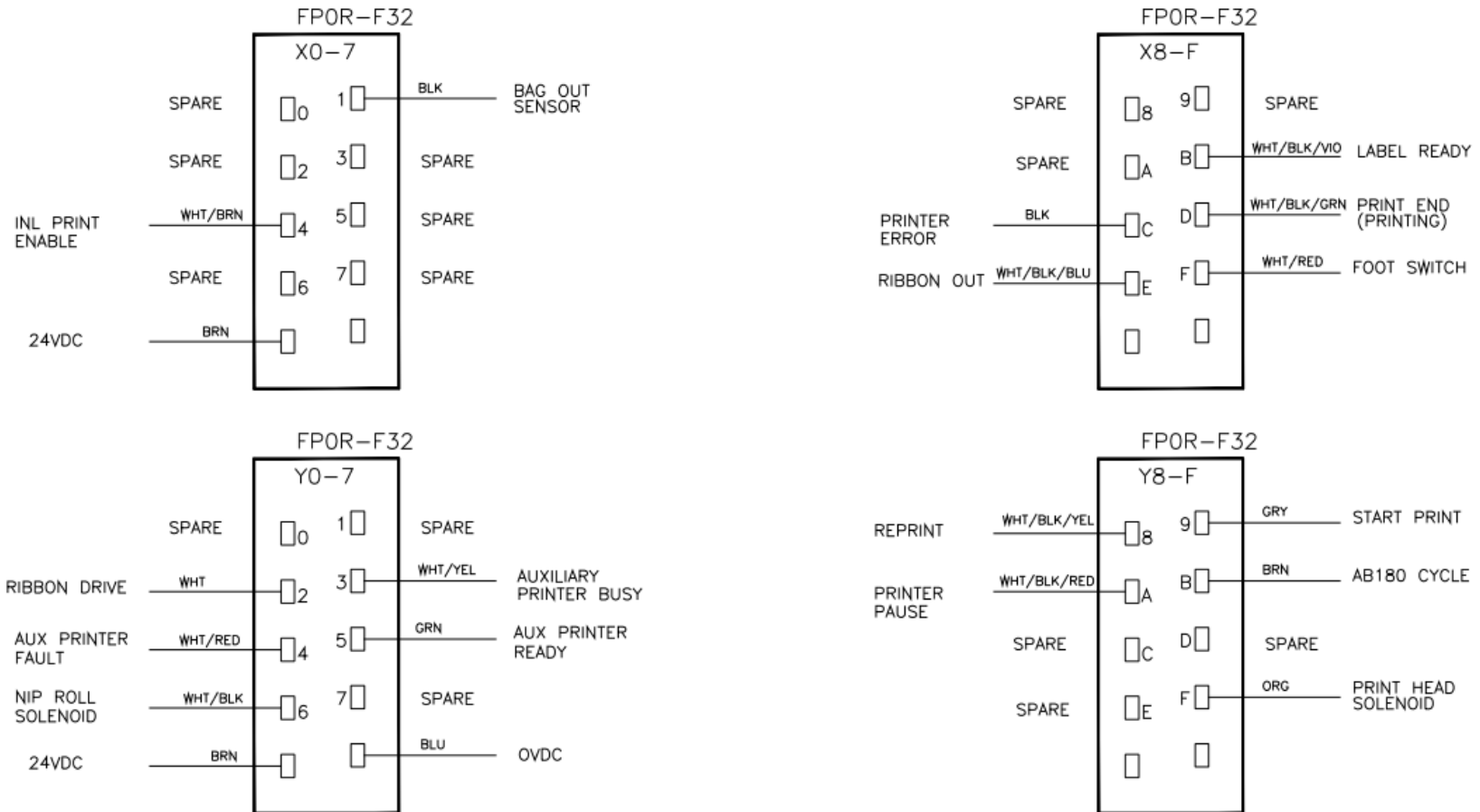

Figure 4-2

### 4.14.1 TIZ-E3\_AXH\_rev1

#### Electrical Drawing

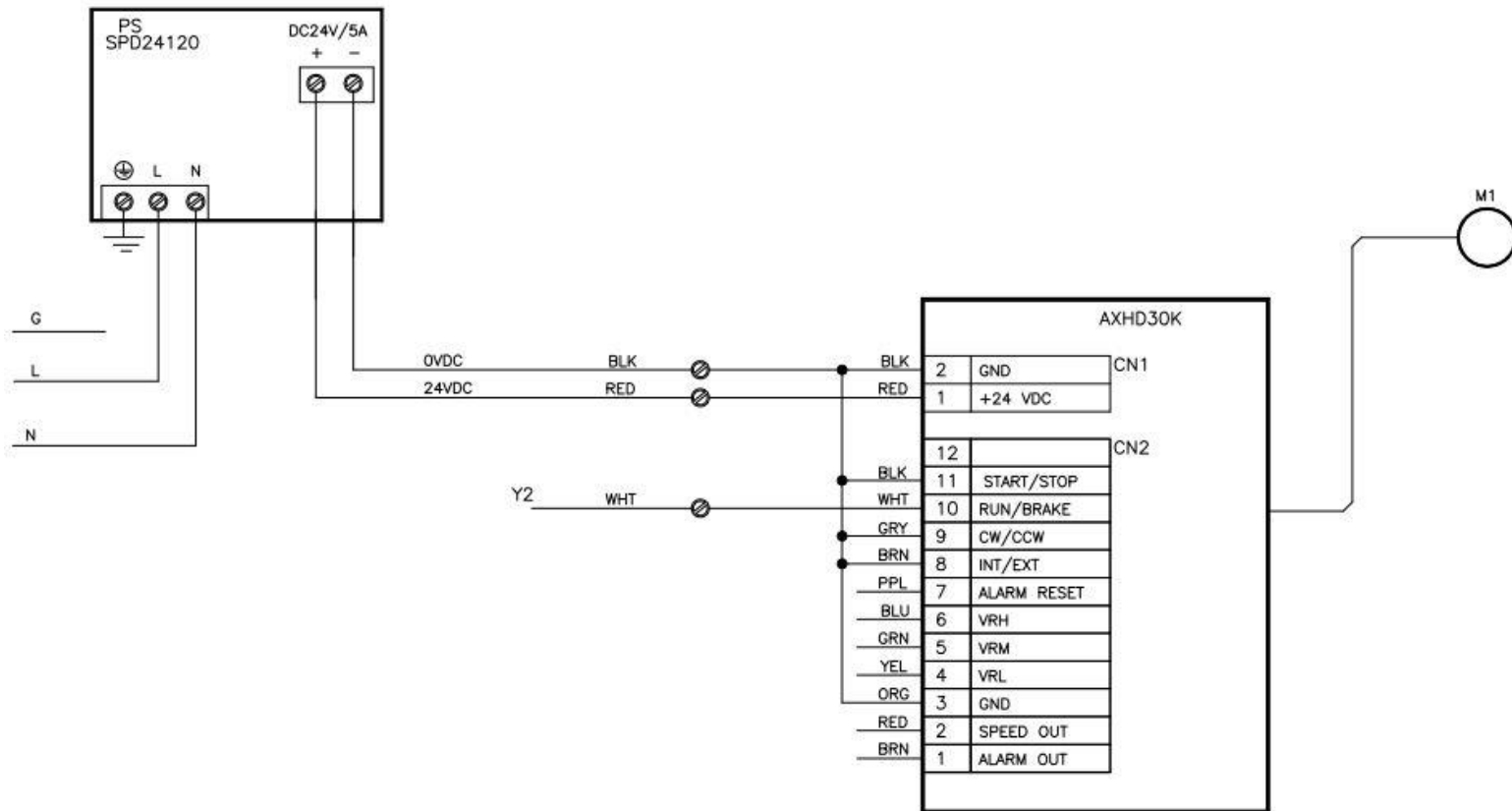

Figure 4-3

### 4.14.1 TIZR-E6\_ZebraIF

#### Electrical Drawing

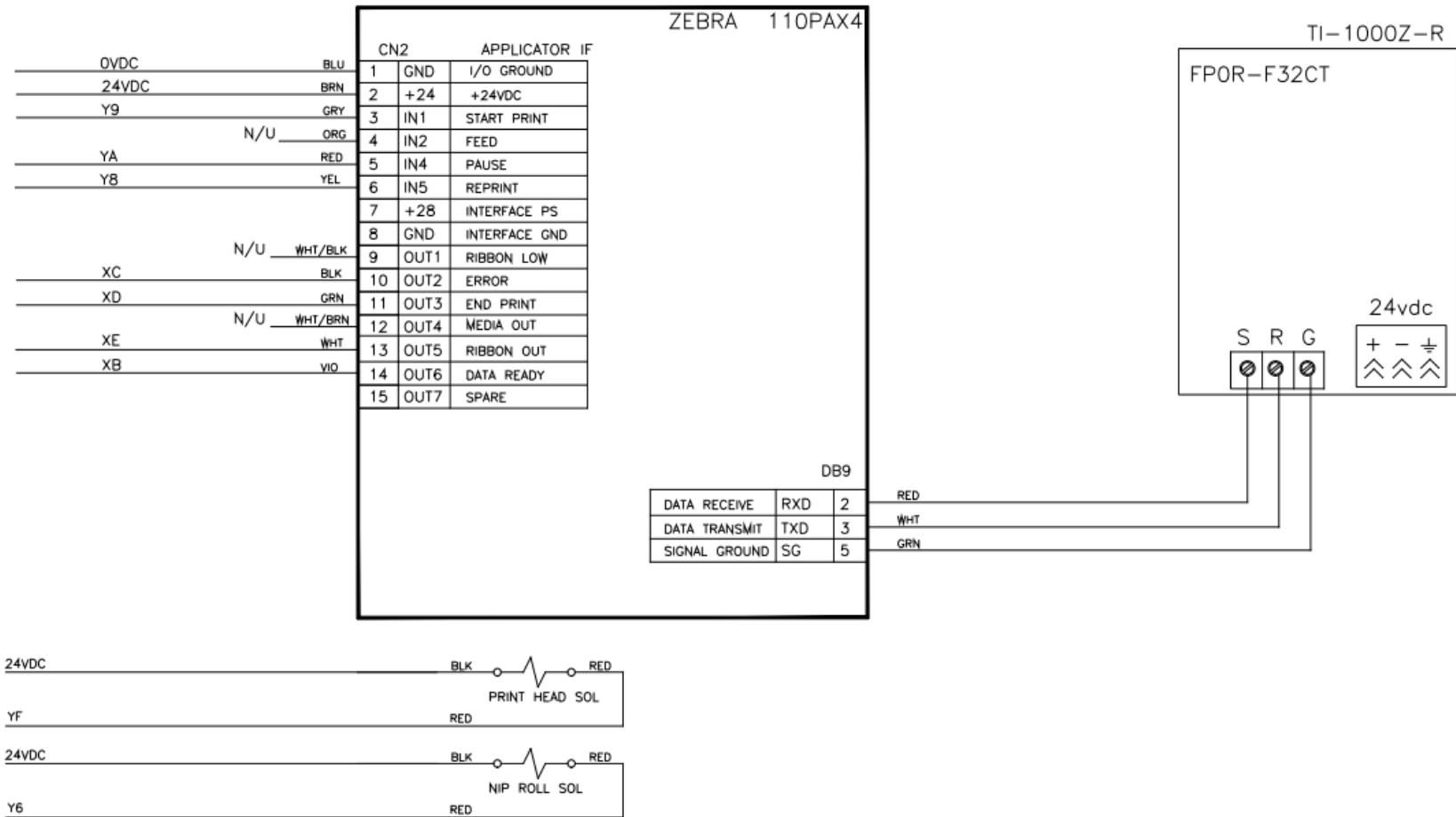

Figure 4-4

### 4.14.1 TIZR-E7\_FP0R-GT02

Electrical Drawing

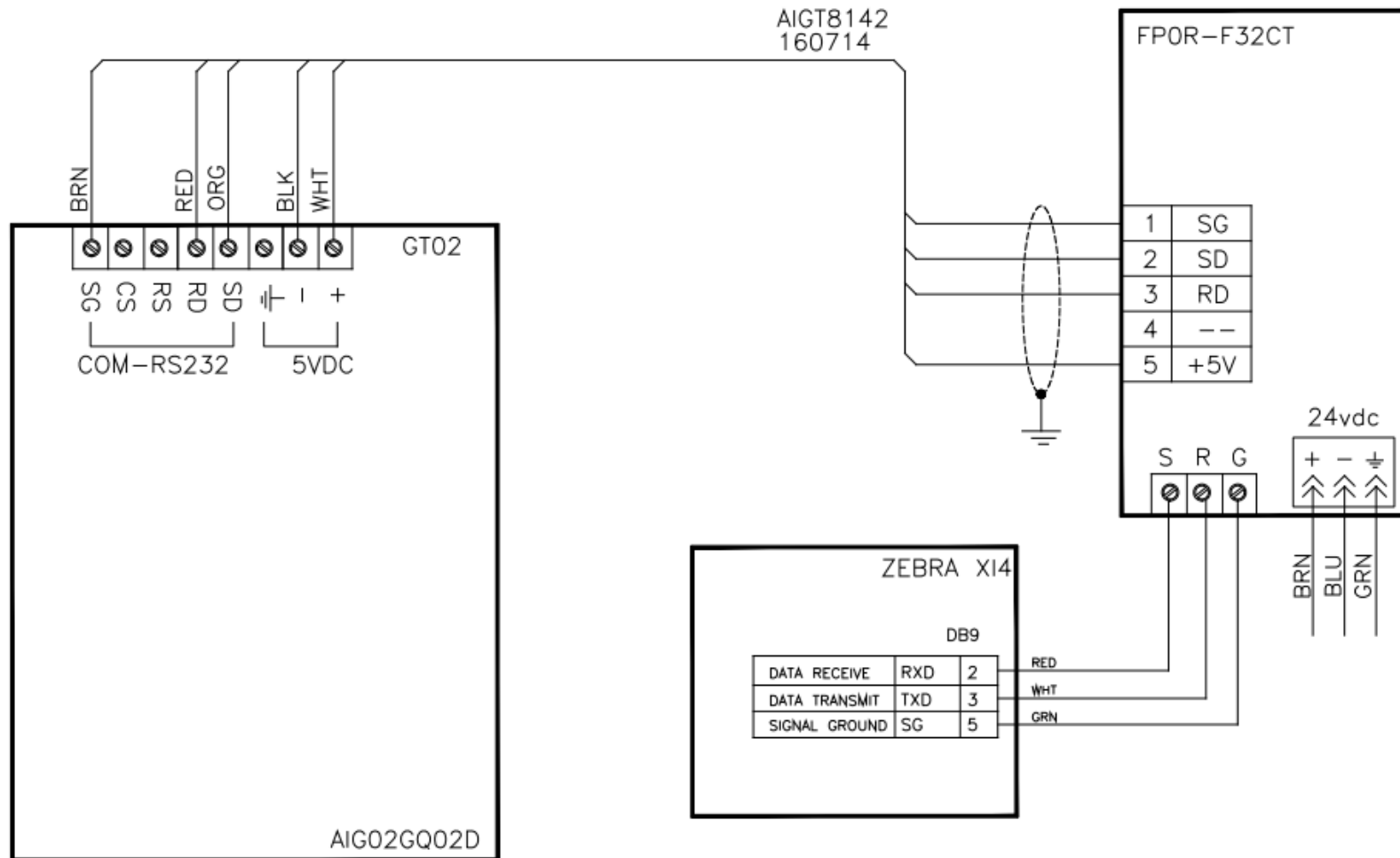

Figure 4-5

### 4.14.1 TIZR-E9\_CB IF

#### Electrical Drawing

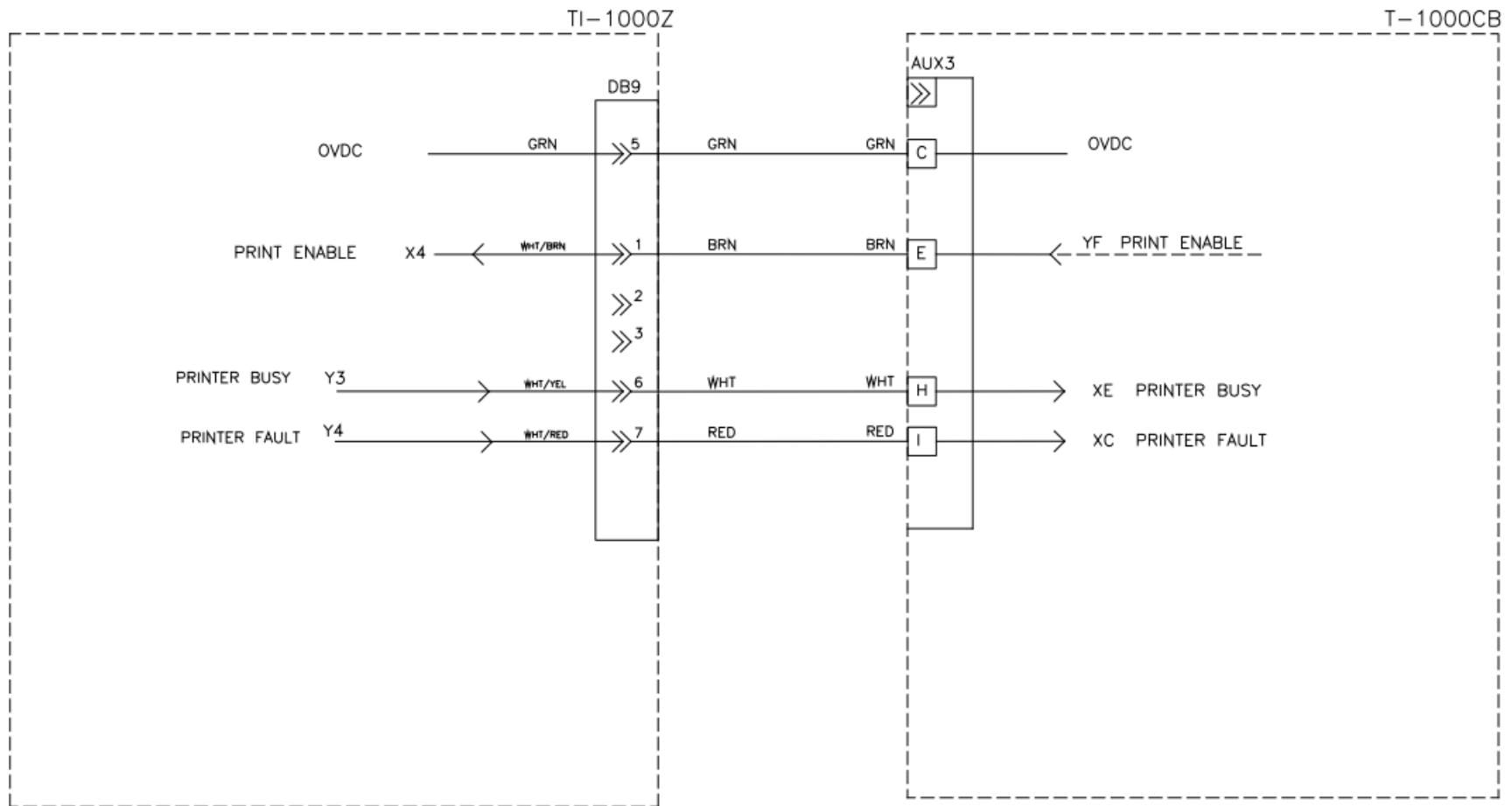

Figure 4-6

### 4.14.1 TIZ-E8\_AuxIF\_rev4

#### Electrical Drawing

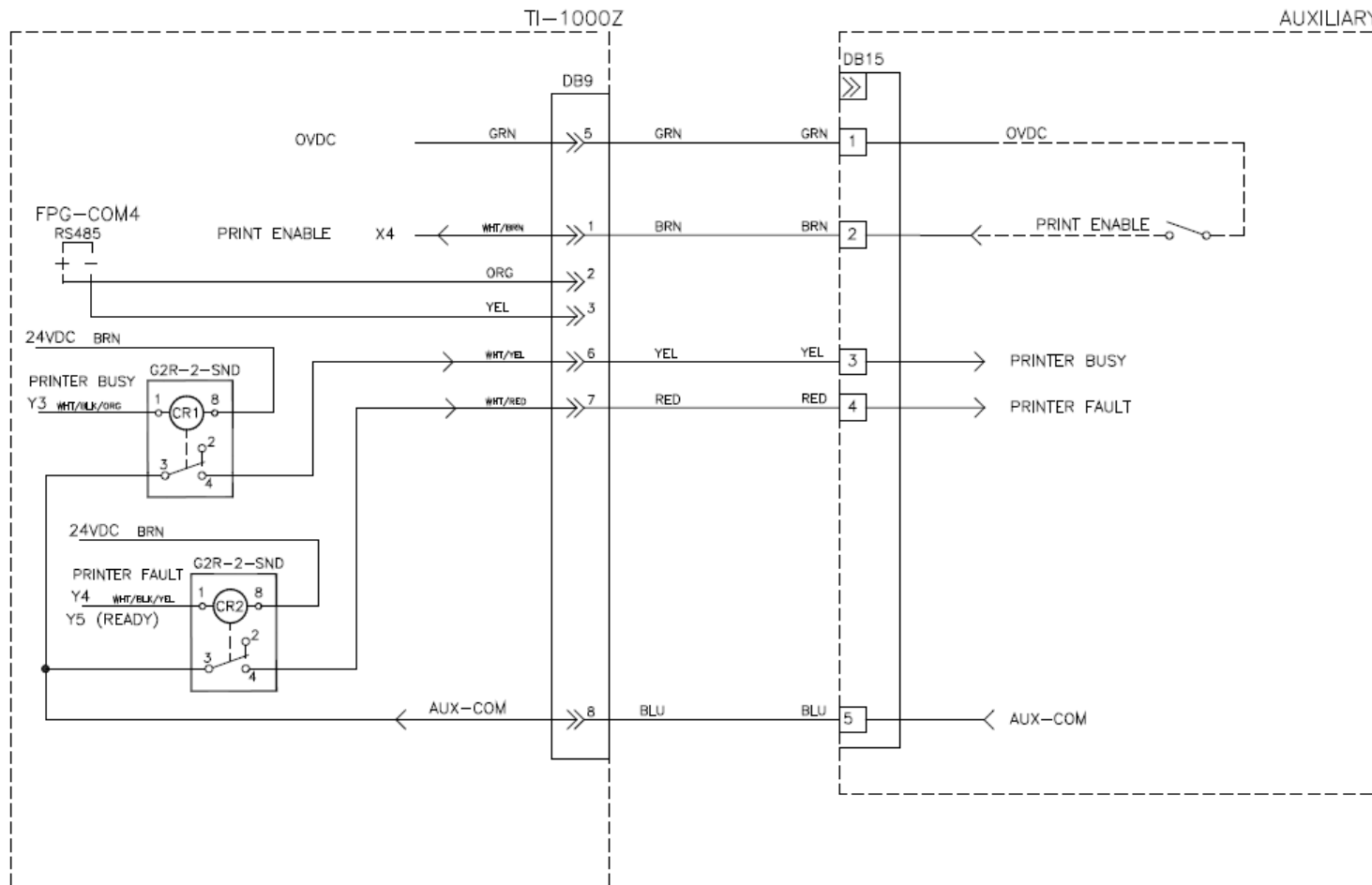

Figure 4-7

This page intentionally left blank.



# Chapter 5: Parts and Drawings

---

Ti-1000Z Inline Thermal Printer

Electronics Assembly

Mounting Assembly

Nip Roll Assembly

Printer Register

Zebra Printer Assembly

Zebra Printer Assembly, Continued

## 5.1 Ti-1000Z Inline Thermal Printer

T-Ti1000Z

ITEM NO.	QTY.	PART NO.	DESCRIPTION
1	1	TA-T2Z-2000	MOUNTING ASSEMBLY
2	1	TA-T2Z-8010	ZEBRA PRINTER ASSEMBLY
3	1	TA-T2Z-2000-1	PRINTER NIP ASSEMBLY
4	1	TA-T2Z-1000	PRINTER ELECTRONICS
5	1	TA-T2Z-4000	PRINTER REGISTER

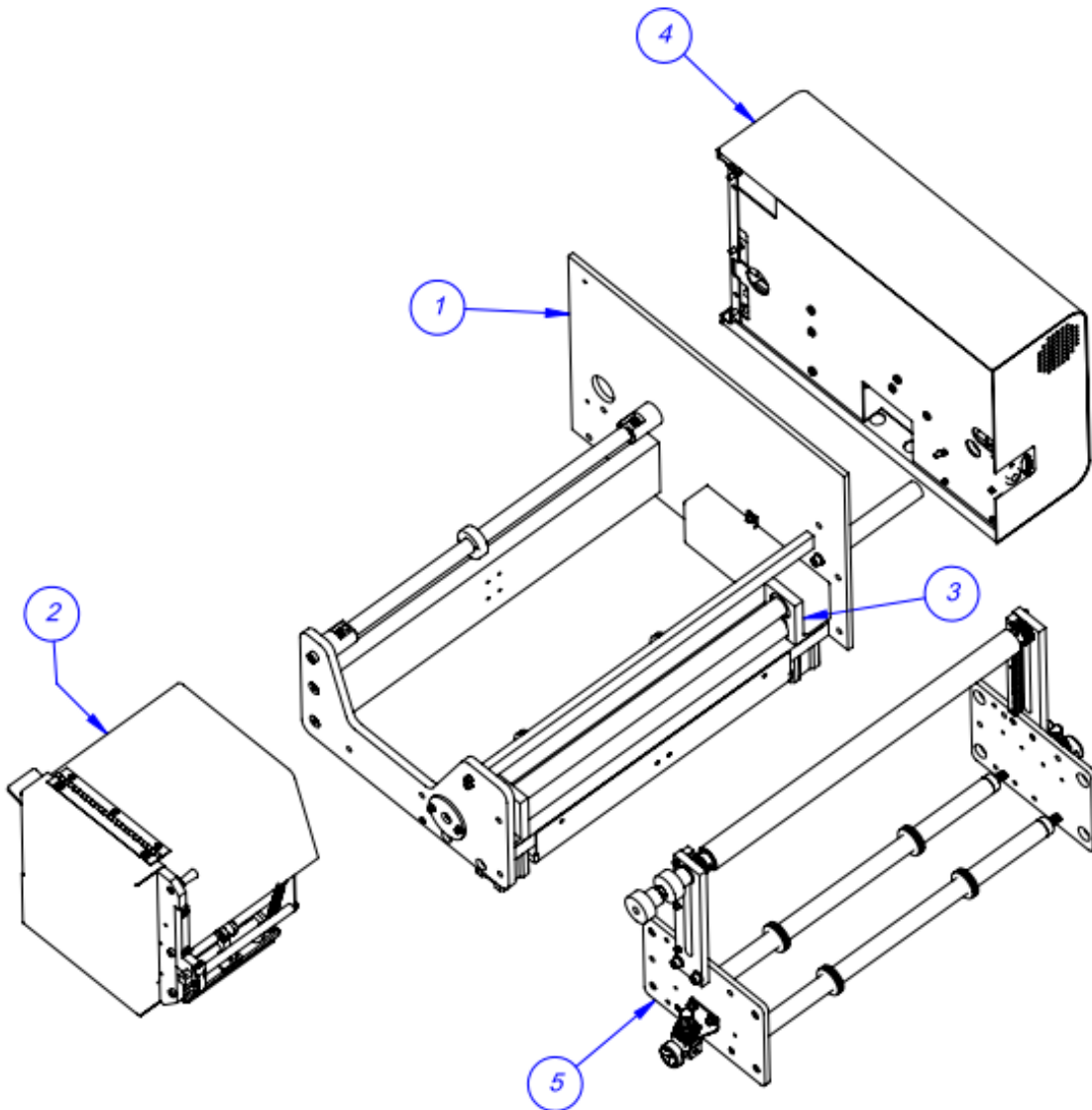

## 5.2 Electronics Assembly

TA-T2Z-1000

ITEM NO.	QTY.	PART NO.	DESCRIPTION
1	1	TP-T2Z1005	ELECTRONICS BASE
2	2	TP-212247	PIN D-SUB FEMALE
3	1	TP-215384	POWER SWITCH
4	1	TP-218020	DIN RAIL
5	1	TP-220521, 214111, 220516	PLC, BATTERY & COMM 2 CAS
6	1	TP-212246	9-PIN D-SUB MALE CUP
7	1	TP-207216, TP-207224	FUSE HOLDER & 5A FUSE
8	1	TP-212410	AC OUTLET
9	14	TP-208142	TERMINAL BLOCK
10	1	TP-218020	DIN RAIL
11	1	TP-212160	5-POSI MINI DIM
12	1	TP-112240	POWER CORD STRAIN RELIEF
13	1	VP-Z-P1053360-016 (017)	LOGIC BOARD, XI4, 8MB (64MB)
14	1	TP-213361	24VDC, 65W POWER SUPPLY
15	1	TP-205108	FILTER, RFI, 10A
16	1	TP-501156	DC MOTOR DRIVE, DRIVEN PRINT ROLL
17	1	TP-T2Z1007	OVERLAY
18	1	TP-T2Z1004	APPLICATOR BOARD MOUNT
19	1	VP-Z-P1011156	XI4 24-28V APPLICATOR INTERFACE OPTION. MAINTENANCE KIT
20	1	VP-Z-P1006134	RIBBON OUT SENSOR MAINTENANCE KIT
21	4	TP-214273	STAND-OFF, NYLON, 1/2", #4-40
22	1	TP-T2Z1018	POWER SUPPLY MOUNT
23	1	VP-Z-1058301	XI4 ZEBRA POWER SUPPLY (REV A)

# Electronics Assembly

TA-T2Z-1000

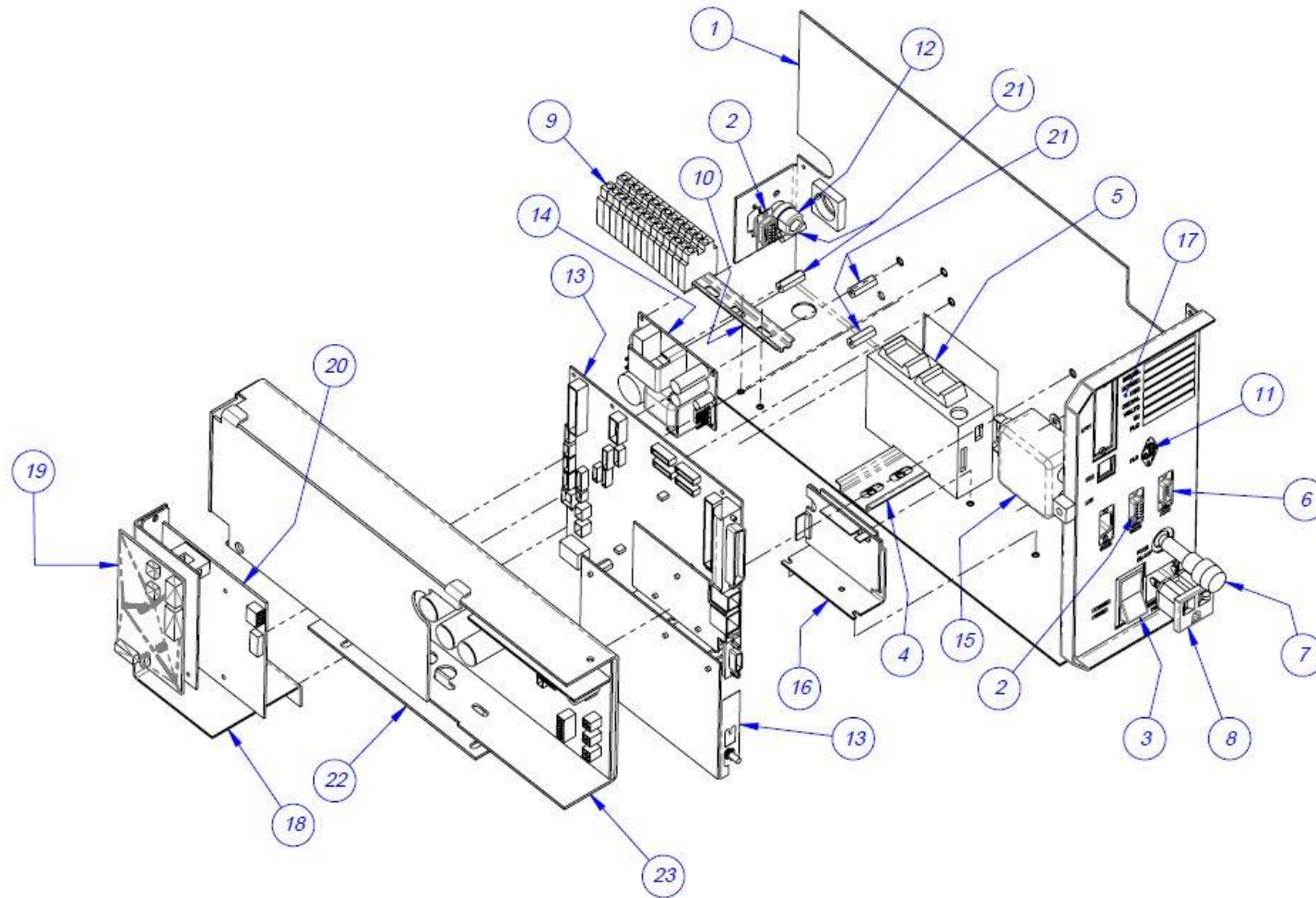

### 5.3 Mounting Assembly

TA-T2Z-2000

ITEM NO.	QTY.	PART NO.	DESCRIPTION
1	1	TP-T2Z2002-1	MOUNTING SIDE PLATE - RIGHT SIDE
2	1	TP-T2Z2002-2	MOUNTING SIDE PLATE - LEFT SIDE
3	1	TP-T2Z2007	SUPPORT BRACE
4	2	TP-T14M1035	GUIDE ROD HOLDER
5	1	TP-T2Z2004	PIVOT SHAFT
6	1	TP-T2Z2005	LATCH BAR
7	1	TP-T2Z2011	BEARING PLATE
8	2	TP-504097	BEARING
9	1	TP-T2Z2006	PRINT HEAD ROLLER
10	1	TP-T1MC00052	STANDARD ROLLER
11	1	TP-T2Z2022	TUBING COVER
12	1	TP-T2Z2013	BELT COVER
13	1	TP-T2Z2012	COVER PANEL STAND-OFF
14	1	TP-T15M8007	BELT TENSIONER
15	1	VP-Z-G46199M	300 DPI ZEBRA MOTOR
16	2	TP-106106	SLOTTED SPRING PIN
17	2	TP-108099	COMPRESSION SPRING
18	2	TP-111010	SPRING CLOSURE COLLAR
19	1	TP-111108	SHAFT COLLAR
20	1	TP-104186	SPACER
21	1	TP-504138	CAM FOLLOWER
22	1	TP-306010	RUBBER EDGE TRIM
23	1	TA-T2Z-2000-1	PRINTER NIP ASSEMBLY

# Mounting Assembly

TA-T2Z-2000

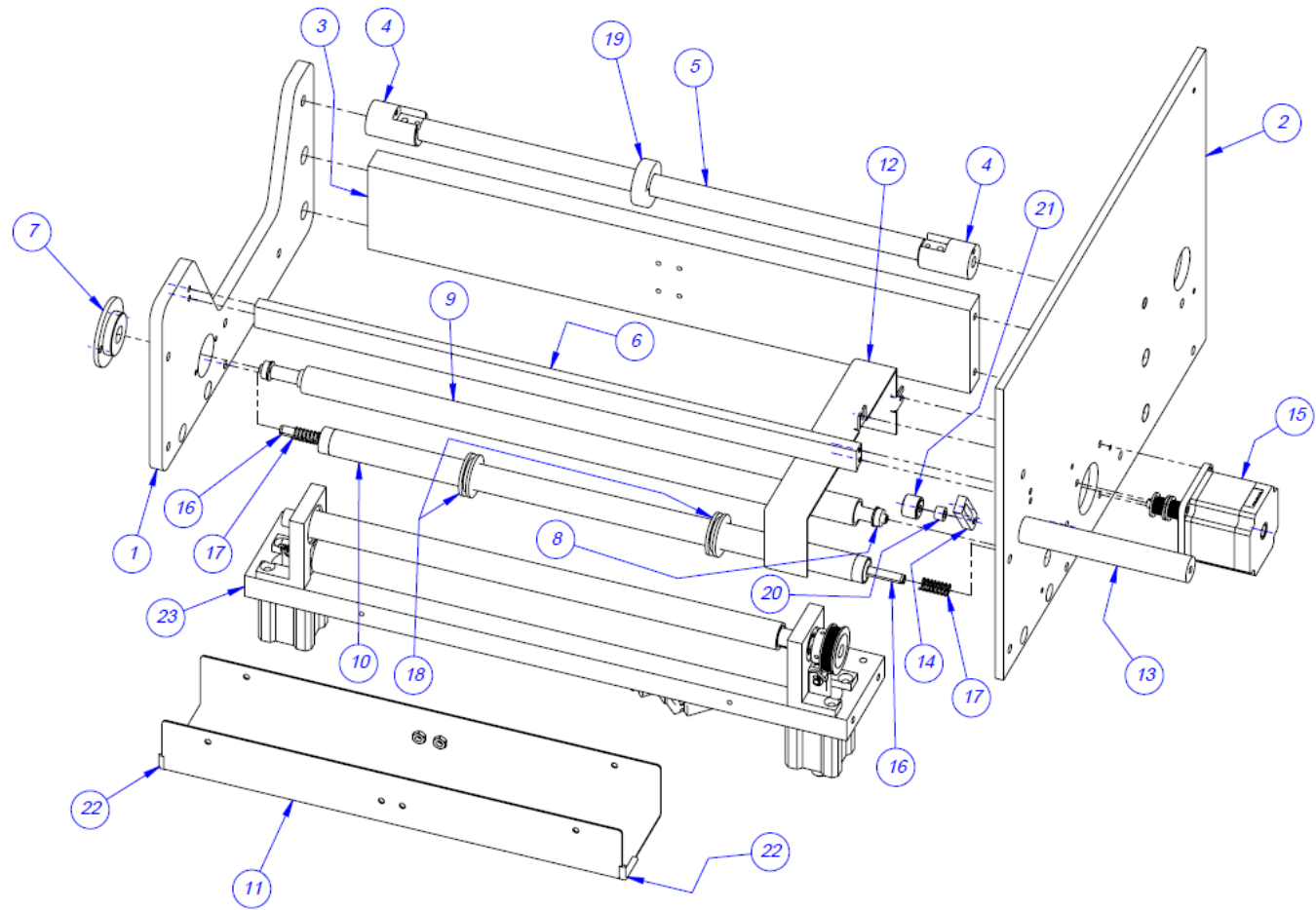

NOTE:  
ITEM 17 "VP-Z-46198M ZEBRA MOTOR" IN THIS ASSEMBLY IS TAKEN FROM ASSEMBLY  
TA-T15-8000 AND REPLACED IN THAT ASSEMBLY WITH MOTOR TP-501155.

THE PARTS THAT MAKE UP THE PRINTER NIP ASSEMBLY TA-T2Z2000-1 ARE ALSO PART  
OF THIS ASSEMBLY. SEE DRAWING TA-T2Z2000-1 FOR THE REMAINING PART NUMBERS

## 5.4 Nip Roll Assembly

TA-T2Z-2000-1

ITEM NO.	QTY.	PART NO.	DESCRIPTION
1	1	TP-T2Z2016	NIP ROLL SUPPORT BRACE
2	2	TP-403236	AIR CYLINDER
3	2	TP-103533	SCREW, 1/4-28 x 1 SET
4	2	TP-T2Z2029	MODIFIED CLEVIS
5	2	TP-T2Z2028	BEARING HOUSING
6	1	TP-T2Z2027	DRIVEN NIP ROLL
7	2	TP-504129	RADIAL BEARING
8	1	TP-T2Z2019	DRIVEN NIP ROLL
9	2	TP-401277	ELBOW, 1/4 TUBE
10	2	TP-402186	FLOW CONTROL VALVE, #10-32
11	2	TP-401254	UNION TEE, 1/4"
12	1	TP-402175	AIR VALVE BRACKET, SX3000-16-1A
13	1	TP-402255	AIR VALVE WITH CONNECTOR
14	2	TP-504106	BEARING, NICE
15	1	TP-T2Z2025	NIP ROLL DEAD SHAFT
16	1	TP-T2Z2026	ROLLER TUBE
17	2	TP-404263	MUFFLER
18	1	TP-401265	STRAIGHT CONNECTOR
19	1	TP-T2Z2032	SENSOR BRACKET
20	1	TP-216112	PHOTOELECTRIC SENSOR

# Nip Roll Assembly

TA-T2Z-2000-1

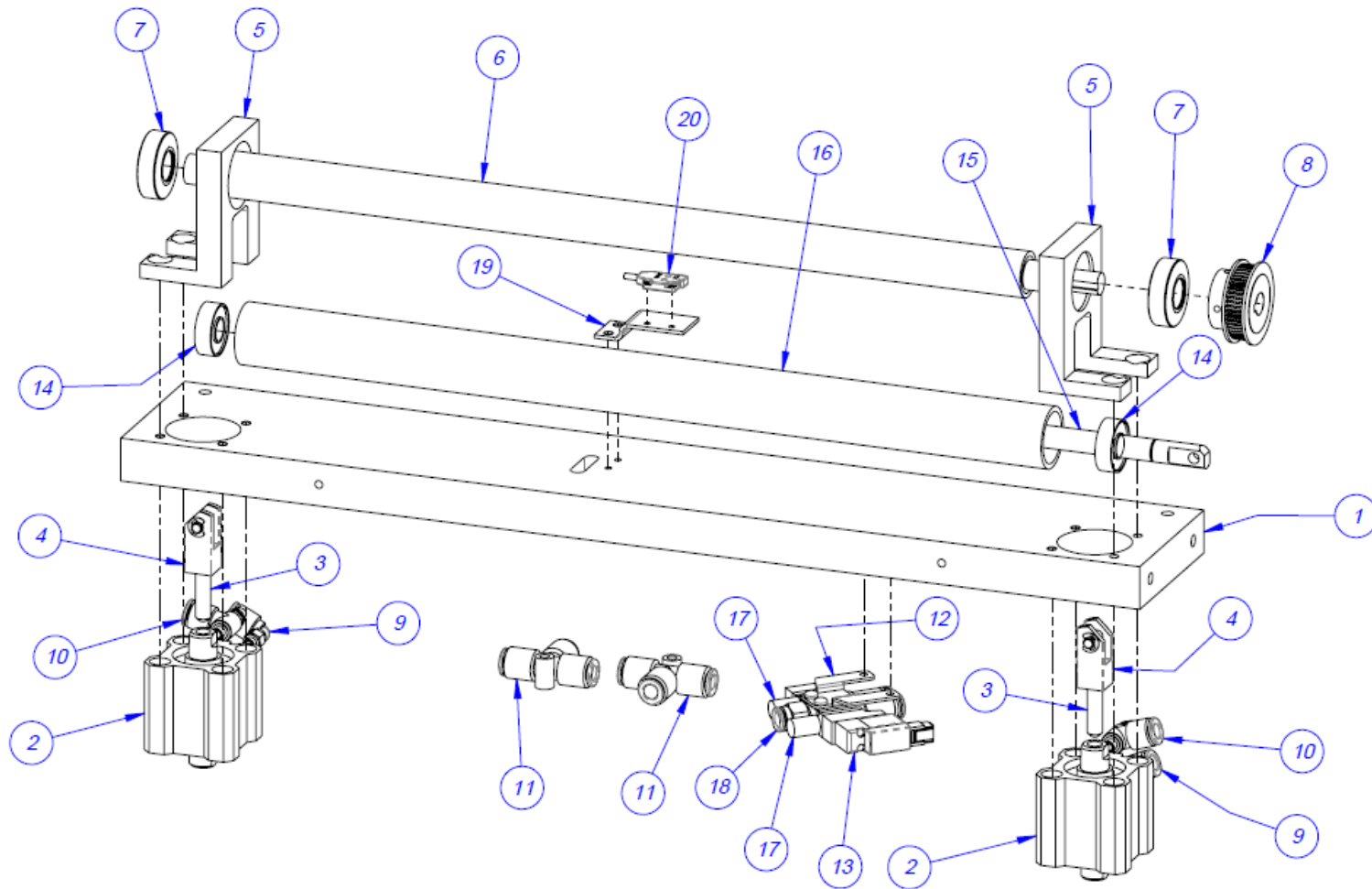



## 5.5 Printer Register

TA-T2Z-4000

ITEM NO.	QTY.	PART NO.	DESCRIPTION
1	2	TP-T2Z4001	PRINTER MOUNTING BRACKET
2	2	TP-T2Z4002	RACK MOUNT
3	2	TP-406259	MINI-REG ASSEMBLY
4	2	TP-T2Z4003	SHORT GEAR RACK
5	1	TP-T2Z4005	GEAR
6	1	TP-T2Z4004	GEAR
7	2	TP-107108	FLANGED BUSHING
8	1	TP-T2Z4007	ROLLER TUBE
9	2	TP-T1MC00052	GUIDE ROLLER (PRINT REG)
10	4	TP-106106	SPRING PIN
11	2	TP-T2Z4010	BUSHING CAGE
12	4	TP-108099	COMPRESSION SPRING
13	4	TP-111010	SPRING CLOSURE COLLAR
14	1	TP-106109	1/8" X 3/4" SLOTTED SPRING PIN
15	1	TP-T2Z4006	ROLLER SHAFT
16	2	TP-109149	HANDLE, KNURLED STEEL
17	1	TP-102126	WASHER, 3/8" EXTERNAL TOOTH LW
18	1	TP-101123	NUT, 3/8-16 HEX JAM NUT
19	1	TP-102144	WASHER, 3/8" FLAT

# Printer Register

TA-T2Z-4000

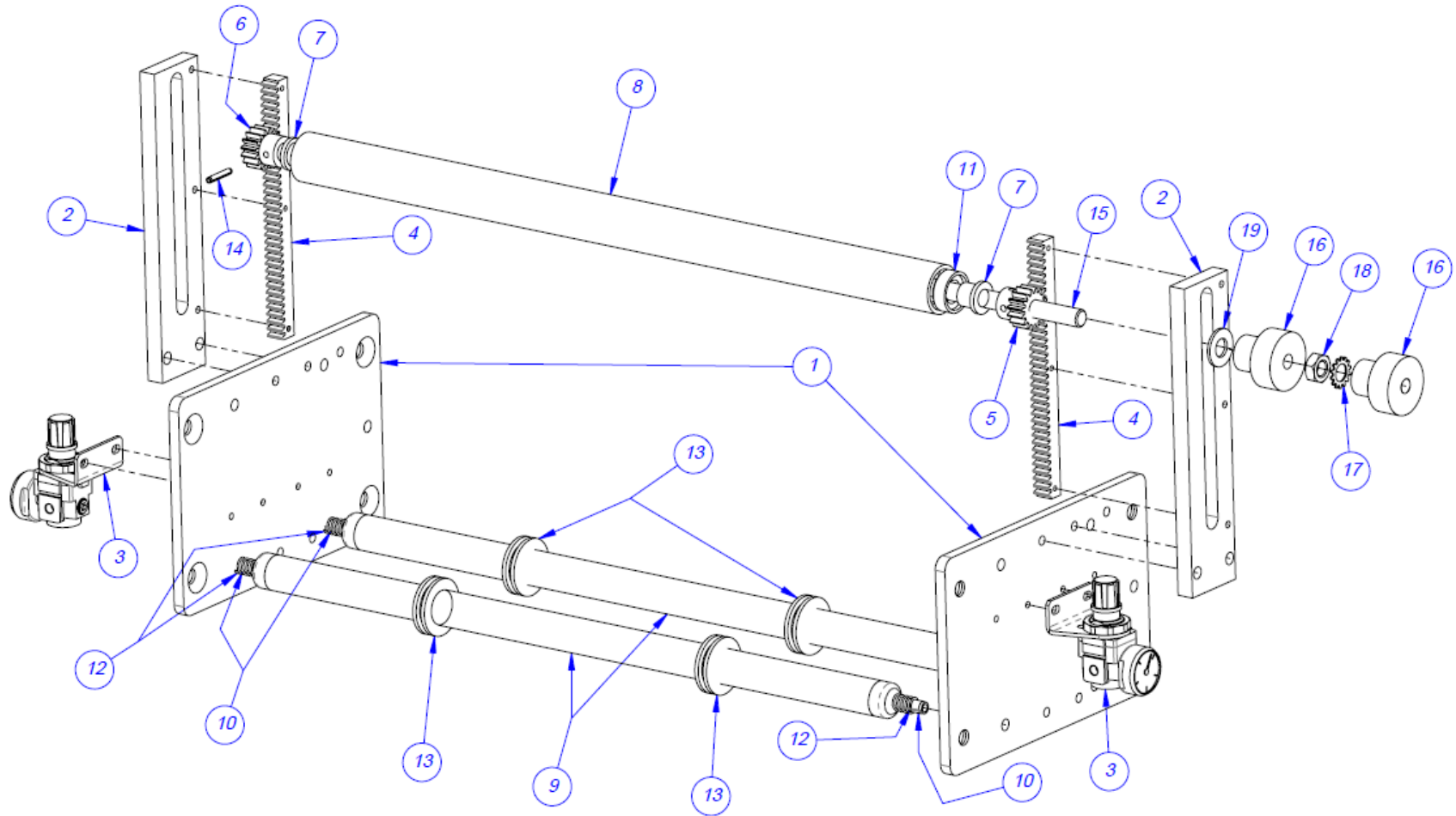

## 5.6 Zebra Printer Assembly

TA-T2Z-8010

ITEM NO.	QTY.	PART NO.	DESCRIPTION
1	1	TA-T15-8000-Z	ZEBRA PRINTER ASSEMBLY
2	1	TP-T2Z8101	HINGE ASSEMBLY
3	1	TP-T2Z8102	LEXAN PRINTER GUARD
4	1	TP-T2Z2010	STOP BAR
5	1	TP-T2Z2014	PIVOT BLOCK BRACKET
6	1	TP-T15M8105	BLADE DRAW LATCH
7	3	TP-103212	SCREW, BHCS 8-32 X 1/2 S.S.
8	3	TP-102103	WASHER, #8 INT. TOOTH LW
9	3	TP-101103	NUT, #8-32 HEX
10	2	TP-102132	WASHER, #6 FLAT
11	2	TP-102152	WASHER, #6 LOCK
12	2	TP-103207	SCREW, BHCS 6-32 X 3/8
13	2	TP-102154	WASHER, #10 LOCK
14	1	TP-103216	SCREW, BHCS 10-24 X 1/2" S.S.
15	1	TP-103123	SCREW, SHCS 10-24 X 1/2" S.S.
16	2	TP-103395	SCREW, FHCS #8-32 X 5/8
17	2	TP-102101	WASHER, #4 INT. TOOTH LW
18	2	TP-103214	SCREW, BHCS 8-32 X 1"

# Zebra Printer Assembly

TA-T2Z-8010

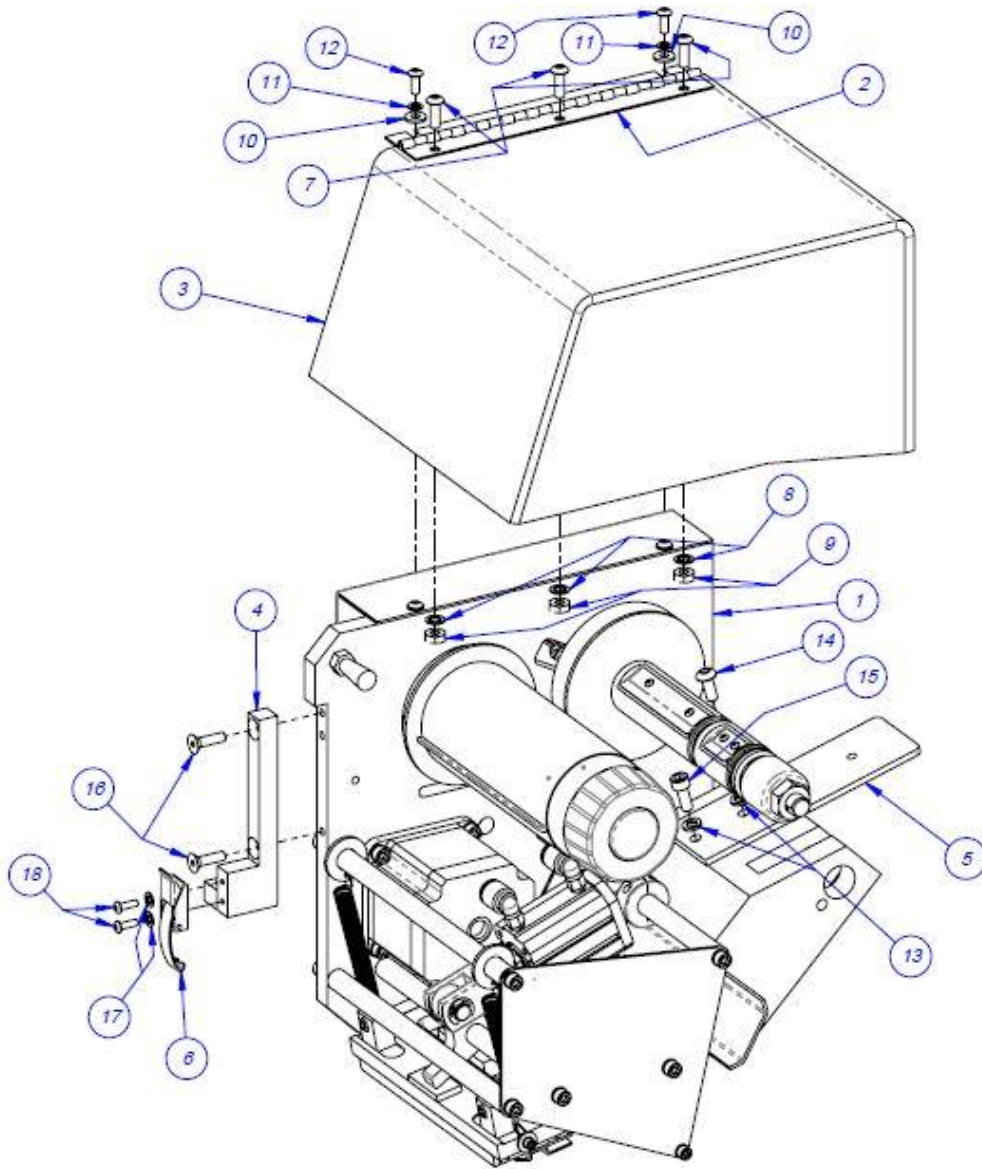

## 5.7 Zebra Printer Assembly, Continued

TA-T15-8000

ITEM NO.	QTY.	PART NO.	DESCRIPTION
1	1	TP-T15M8001	PRINTER SIDE PLATE
2	1	TP-T15M8002	MOUNTING PLATE PRINT HEAD
3	2	TP-T15M8003	ADJUSTMENT BLOCK
4	5	TP-T15M8004	SUPPORT ROD
5	1	TP-T15M8005	CAM-PRINT HEAD
6	1	TP-T15M8006	CYLINDER MOUNT
7	1	TP-T15M8007	BELT TENSIONER
8	1	TP-T15M8008	BELT GUARD
9	1	TP-T15M8010	LOCATING SPACER
10	1	TP-T15M8011	SENSOR BRACKET
11	2	TP-T15M8012	SPRING MOUNT
12	2	TP-T15M8013	ADJUSTMENT ROD
13	2	TP-T15M8014	ADJUSTMENT ROD BLOCK
14	1	TP-T15M8030	END PLATE
15	1	TP-T15M8031	ROLLER SHAFT
16	1	TP-T15M8032	SHAFT MOUNT
17	1	TP-T15M0036	PIVOT BLOCK
18	1	TP-T15M8038	WEAR SURFACE
19	1	TP-T15M8042	RIBBON TAKE-UP PULLEY
20	1	TP-T15M8043	LOCATING SPACER
21	1	TP-T15M8044	SUPPLY SPOOL SPACER
22	1	TA-Z-41150M	RIBBON TAKE-UP SPINDLE
23	2	TP-108133	SPRING
24	2	TP-108099	COMPRESSION SPRING,.040 GAUGE
25	2	TP-106304	10MM DOWEL PIN
26	2	TP-111107	COLLAR CLAMP
27	1	TP-402260	PNEUMATIC VALVE
28	1	TP-401265	AIR FITTING
29	2	TP-401294	1/8-INCH FITTING
30	1	TP-403140	AIR CYLINDER
31	2	TP-404263	MUFFLER
32	1	VP-Z-P1006058	xi4 RIBBON SUPPLY SPINDLE KIT
33	1	VP-Z-P1004230	PRINT HEAD
34	1	VP-Z-46198M	203 DPI Zebra Motor
35	2	TP-401294-1	MALE CONNECTOR, 1/8" TUBE

36	1	TP-404148	CLEVIS
37	1	TP-402175	BRACKET
38	1	TP-109225	FINGER KNOB
39	1	TP-504138	CAM FOLLOWER
40	1	TP-503113	BELT
41	1	TP-504175	CLUTCH BEARING
42	1	TP-107116	SLEEVE BUSHING
43	2	TP-102119	NYLON WASHER
44	1	TP-104112	NYLON SPACER
45	1	VP-Z-P1006134	ZEBRA RIBBON OUT SENSOR

# Zebra Printer Assembly

TA-T15-8000

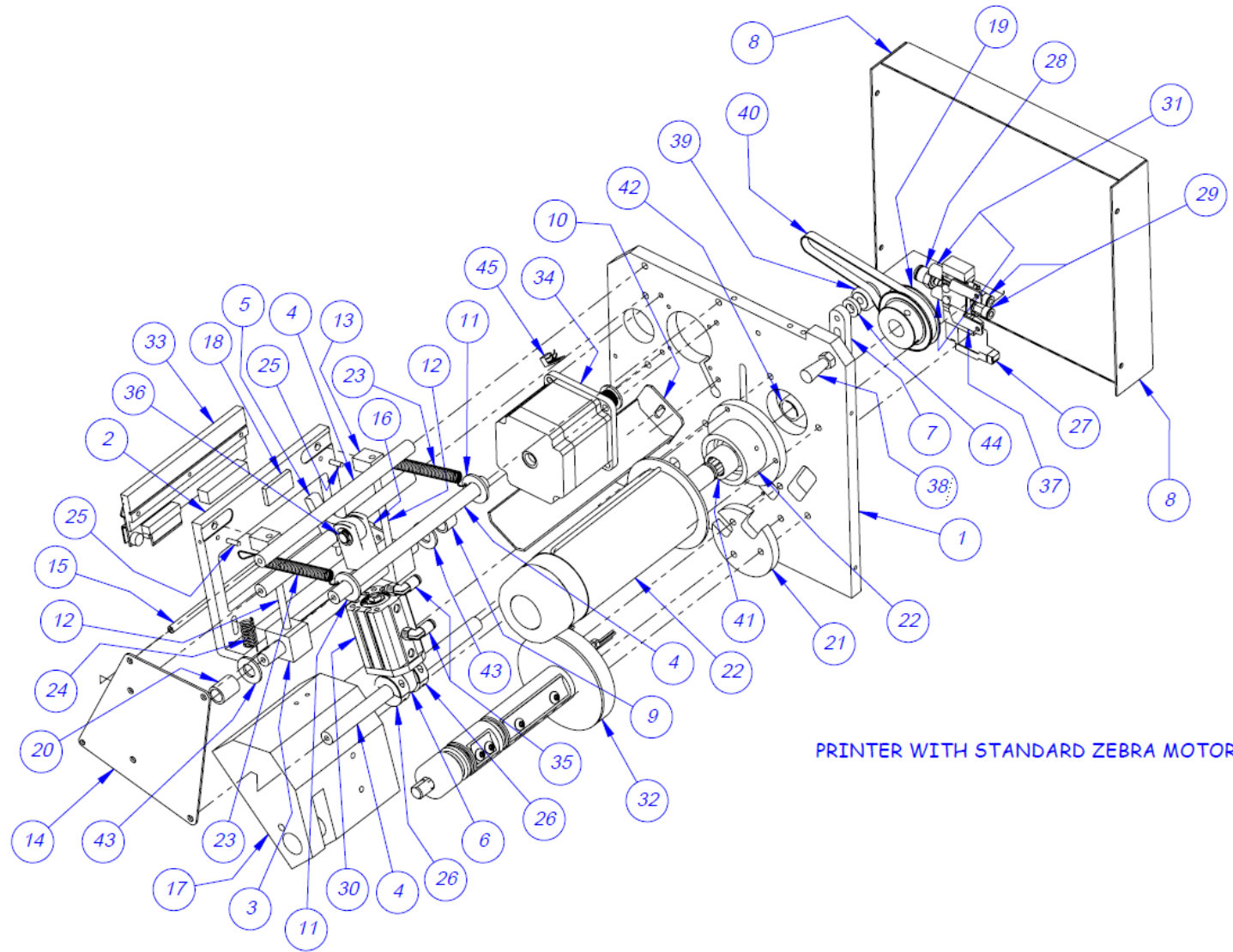

PRINTER WITH STANDARD ZEBRA MOTOR