

T-1000-S14

Advanced Poly-Bagger™

Operation Guide, Ver 5

Setup, Operation and Parts Manual



Advanced
Poly-Packaging, Inc.

1331 Emmitt Road, Akron, Ohio 44306
Phone US Only: Toll Free (800) 754-4403
Phone: 330-785-4000
Fax (330) 785-4010
Email: sales@advancedpoly.com
Web: www.advancedpoly.com

Acknowledgments

Manual written by: Stuart Baker

Copyright

1995 (Ver 1), 2001 (Ver 2), 2003 (Ver 3), 2006 (Ver 4), 2007 (Ver 5) Advanced Poly-Packaging, Inc. (APPI). All rights reserved.

This manual and the program operating the equipment described in it are copyrighted. You may not copy this manual in whole or part without the consent of Advanced Poly-Packaging, Inc.

All information pertaining to the promotion, sale, distribution, operation, and maintenance of the T-1000 ADVANCED POLY-BAGGER including this manual, drawings, schematic, wiring diagrams, VHF video tapes, brochures, specification sheets, figures, charts, or any other information, due to its proprietary design and manufacture remain the property of Advanced Poly Packaging, Inc. Unauthorized duplication, distribution, or disclosure to third parties without the express permission of Advanced Poly-Packaging, Inc. is strictly prohibited.

Trademarks

T-1000 Advanced Poly-Bagger is a trademark of Advanced Poly-Packaging, Inc. Advanced Poly-Packaging, Inc. owns also the following trademarks: Advanced Poly-Bags, Twin-Seal, Advanced Poly-Pack, Advanced Poly-Bag, Blist-a-Bag.

Limited Warranty & Disclaimer

Warranty period is 12 months or 1,000,000 cycles whichever comes first. The warranty commences on the date of delivery of the equipment to the Purchaser.

APPI warrants to the Purchaser that the equipment is free from defects in workmanship or material under normal use and service. During the warranty period, APPI agrees to repair or replace, at its sole option, without charge to Purchaser, any defective component part of the equipment. To obtain service, Purchaser must return the equipment or component to APPI or an authorized APPI distributor or service representative in an adequate container for shipping. Any shipping charges, insurance, or other fees must be paid by Purchaser and all risk for the equipment shall remain with Purchaser until such time as APPI takes receipt of the equipment. Upon receipt, APPI, the authorized distributor or service representative will promptly repair or replace the defective component and then return the equipment or component to Purchaser, shipping charges, insurance and additional fees prepaid. APPI may use reconditioned or like new parts or units, at its sole option, when repairing any component or equipment. Repaired products shall carry the same amount of outstanding warranty as from original purchase. Any claim under the warranty must include a dated proof of delivery. In any event, APPI's liability for defective components or equipment is limited to repairing or replacing the components.

This warranty is contingent upon proper use of the equipment by Purchaser and does not cover: expendable component part such as thermocouple wire, heater cartridge, rollers, bushings, and the like; or if damage is due to accident, unusual physical, electrical or electromechanical stress, neglect, misuse, failure of electric power, water damage (from airlines), improper environmental conditions, transportation, tampering with or altering of the equipment, packaging of corrosive or contaminating products or other products damaging to components, and equipment or components not owned or in the possession of original Purchaser

APPI will not be liable for loss of production, profits, lost savings, special, incidental, consequential, indirect, or other similar damages arising from breach of warranty, breach of contract, negligence, or their legal action even if APPI or its agent has been advised of the possibility of such damages or for any claim brought against the Purchaser by another party.

This warranty allocates risks of equipment failure between Purchaser and APPI. APPI's pricing reflects this allocation of risk and the limitations of liability contained in this warranty. The warranty set forth above is in lieu of all other express warranties, whether oral or written. The agents, employees, distributors, and dealers of APPI are not authorized to make modifications to this warranty, or additional warranties binding on APPI. Accordingly, additional statements such as dealer advertising or presentations, whether oral or written, do not constitute warranties by APPI and should not be relied upon.

Warranty on equipment is considered void when outstanding balances become delinquent (over 30 days late - 60 days after ship date).

Equipment Integration to other Equipment: APPI assumes no responsibility for the integration of its products to other products or within a system unless APPI performs the integration, testing and provides the results of the tests to the purchaser in writing. Furthermore, APPI assumes no responsibility for bag sizing whether suggested or recommended.

Contents

Chapter 1, Introduction

- 1.1 Welcome
- 1.2 Overview
- 1.3 Special Features
- 1.4 System Integration
- 1.5 Options Available
- 1.6 Using This Manual
- 1.7 Registration Information

Chapter 2, Getting Started

- 2.1 Installation Procedures
- 2.2 Air & Power Requirements
- 2.3 Assembly
- 2.4 Air & Power Hookup
- 2.5 Main Power
- 2.6 Bag Threading
- 2.7 Cycle Operation
- 2.8 Note on Adjustments
- 2.9 Energy Conservation & Component Saver

Chapter 3, Touch Screen Operation

- 3.1 Touch Screen Front Panel
- 3.2 Touch Screen Back Panel
- 3.3 Specifications
- 3.4 Touch Screen Contrast Adjustments
- 3.5 Touch Screen Program / Overview
- 3.6 Intro Screen
- 3.7 Operation Screen
- 3.8 Main Menu
- 3.9 Bag Setup Menu
- 3.10 Fill Time
- 3.11 Air Pulse
- 3.12 Seal Point
- 3.13 Seal Time
- 3.14 Reverse
- 3.15 Blow Off
- 3.16 Index Speed
- 3.17 Seal Temperature
- 3.18 Options Menu
- 3.19 LS-10 Load Shelf
- 3.20 FS-10 Flat Seal Assembly / Bag Deflator
- 3.21 TS-10 Trim Seal Assembly
- 3.22 PB-20 Palm Buttons

- 3.23 LC-10 Light Curtain
- 3.24 Estop
- 3.25 Ti-1000 Printer
- 3.26 CF-10 Counting Funnel
- 3.27 AF-10 Accumulating Funnel
- 3.28 BO-20 Bag Open Detector
- 3.29 Bag “Out” Sensor
- 3.30 DF-20 Diverting Funnel
- 3.31 CS-10 Compartment Seal
- 3.32 TS-10 Twin Seal Assembly
- 3.33 MV-10 Seal Validation
- 3.34 BV-10 Barcode Reader
- 3.35 IF-10 Insert Funnel
- 3.36 BO-30 Bag Opening Device
- 3.37 Base Height Adjustment
- 3.38 ST-10 Stack Light Option
- 3.39 UF-5000 Operation Screen
- 3.40 UF-5000 Settings Screen
- 3.41 US-5000 Screens
- 3.42 Auxiliary Screen
- 3.43 Job Save / Recall
- 3.44 Counters
- 3.45 Production Chart
- 3.46 Temperature Graph
- 3.47 Technical Assistance Screen
- 3.48 Pass Code Setup Screen
- 3.49 Options Enable Pass Codes
- 3.50 Valve Station Setup (Options)
- 3.51 Factory Settings
- 3.52 Inputs / Outputs (PLC)
- 3.53 Information Screens / Message Screens

Chapter 4, Operation, Settings & Adjustments

- 4.1 Machine Adjustments
- 4.2 Tracking & Alignment
- 4.3 Compression (Nip) Roller Adjustment
- 4.4 Dancer Assembly
- 4.5 Dancer Bar & Brake Strap
- 4.6 Upper Roller Guides
- 4.7 PTFE Anti-Stick Adjustment
- 4.8 PTFE Anti-Stick Replacement
- 4.9 Pressure Bar Adjustment
- 4.10 Seal Cylinder Adjustment
- 4.11 Pressure Bar Rubber Replacement
- 4.12 Anti-Jam Adjustment
- 4.13 Heater Cartridge Replacement
- 4.14 Thermocouple Wire Replacement

Chapter 5, Parts

- 5.1 Main Assembly
- 5.2 Head Assembly
- 5.3 Flat Load Shelf Sub-Assembly
- 5.4 Main Frame Assembly
- 5.5 Inner Main Frame Assembly
- 5.6 Air Knife Assembly
- 5.7 Upper Roller Finger Assembly
- 5.8 Electrical Panel Assembly
- 5.9 Sealer Frame Assembly
- 5.10 Pneumatics Mounting Valve Assembly
- 5.11 Pressure Bar Sub-Assembly
- 5.12 Heater Bar Sub-Assembly
- 5.13 PTFE Guide Sub-Assembly
- 5.14 Grooved Roller Mounting Sub-Assembly
- 5.15 Bag Finger Grounding Assembly
- 5.16 Latch Sub Assembly
- 5.17 Stand Assembly
- 5.18 Base Assembly
- 5.19 Upper Column Assembly
- 5.20 Dancer Assembly
- 5.21 Film Tension Hub
- 5.22 Dancer Guide
- 5.23 Touch Screen Assembly

Chapter 6, Preventive Maintenance & Scheduled Maintenance

- 6.1 Preventative Maintenance & Schedule Maintenance
- 6.2 P.M. Checklist
- 6.3 Scheduled Maintenance Chart
- 6.4 SP-10 Spare Parts Kit (Level 1)
- 6.5 SP-20 Spare Parts Kit (Level 2)

Chapter 7, Troubleshooting

- 7.1 Troubleshooting
- 7.2 Troubleshooting Checklist
- 7.3 Wiring Tab List
- 7.4 110V Circuit Dwg
- 7.5 Analog / Temperature Controller Circuit Dwg
- 7.6 Stepper Motor Circuit Dwg
- 7.7 Perforation Sensor PCB Circuit Dwg
- 7.8 Auxiliary Interface Circuit Dwg
- 7.9 Solenoid Valve Circuit Dwg
- 7.10 Pneumatic Piping Diagram
- 7.11 PLC IO Listing
- 7.12 Notes

This page intentionally left blank.

Chapter 1, Introduction

Welcome

Overview

Special Features

System Integration

Options Available

Using This Manual

Registration Information

1.1 Introduction

Now that you've decided to upgrade your packaging facilities with the T-1000 Advanced Poly-Bagger from Advanced Poly-Packaging, Inc., we thank you for selecting our equipment, materials and service. Where labor reduction and fast changeover is important, the T-1000 uses Advanced Poly-Bags (pre-opened bags on rolls), manufactured by Advanced Poly-Packaging, Inc. Extensively equipped with several "built-in", ready-to-use options, the T-1000 can package various industrial, medical, molded and food products. With a wide range of bag sizes (2" x 3" (standard frame only) to 14" x 30") and mil thickness (1 mil to 5 mil), we hope the T-1000 will meet all of your bagging needs.

1.2 Overview

The T-1000 ADVANCED POLY-BAGGER™ is a system designed to lower your packaging costs with high speeds, versatility, reliability, and simplicity.

High Speeds - Indexes, opens, seals and tears off a bag at very high rates. Actual packaging speed is dependent on the bag size, equipment options, product characteristics and method of loading.

Versatility - Mobile on rugged castors for packaging at any production station throughout your facility. Ideal for numerous short runs with virtually no production loss for job changeovers since all that is required is a roll change and recalling the bag settings from memory.

Reliability - Crafted from the highest quality components and materials to withstand the most rigorous manufacturing environment; sturdy mounts with castors, and rugged frame guarantee long life and usefulness with minimal maintenance.

Simplicity - A "user-friendly" menu-driven touch screen program allows operators to setup the bag, options and auxiliary equipment, save the settings in memory, and recall those settings for repeat runs.

1.3 Special Features

Energy Conservation & Component Saver - To extend its life and conserve energy in your plant, the T-1000 is programmed to sequentially shut components down when not in use for extended periods. Electric current to the heater bar will discontinue and place the T-1000 in the stop mode during a preset period of nonuse. Shortly thereafter, air flow will be shut off preserving compressed air. A screen saver is also provided.

Pass code Protection - As an option, setting screens can be protected from being altered by unauthorized individuals. Once turned on, this function acts as a "screen save" feature whereas a timer causes the pass code screen to be displayed, from the Operations Menu. Factory settings are protected by a level 1 pass code and should only be provided to authorized maintenance personnel.

Predetermined Counter - Preset the T-1000 to stop after a predetermined number of bags have been packaged. Set the quantity of finished bags to complete a work order or fill a shipping container. Once the work order is complete or the container is full, the T-1000 stops to alert the operator to begin the next work order or to push aside the box to begin filling another. Pressing anywhere on the screen resets the counter and starts the bagging operation with minimum delay.

Totalizing Counter - Reset this counter at the beginning of each shift or day to record packaging production over a period of time.

Maintenance Counter/Chart - Periodically check this counter (total machine cycles) to determine preventative maintenance / component inspection intervals for inspection / maintenance criteria and intervals.

Continuous Strip Option - Leave bags connected in an "endless" strip or a predetermined number of strips of sealed bags.

Communications Port - Allows for auxiliary communications.

Antijam Device - During the loading and sealing operation, this device will detect obstructions and automatically reverse the pressure bar and discontinue the cycle operation.

Castors Assembly - Rugged castors are standard for plant mobility.

1.4 System Integration

The T-1000 is preprogrammed to integrate automatically to major brand vibratory counters and feeders, weigh scales, volumetric fillers, auger fillers and infeed conveyors. As an OEM for numerous equipment manufacturers of infeed systems, we can offer the best available system, with the T-1000 Advanced Poly-Bagger as the integral packaging component. However, APPI cannot be responsible for the successful integration of third party equipment, unless approved and integrated by APPI.

FREE CONSULTATION AND PRODUCT EVALUATION: We invite you to call to discuss your packaging requirements and our free product packaging analysis.

1.5 Additional Options Available

Although the T-1000 is equipped with many "built-in" options described above, various auxiliary options and equipment can easily be added for special purpose packaging. The following options may be purchased from Advanced Poly-Packaging, Inc

LS-10 Load / Support Shelf - Provides support for heavier packages when dropped into bag. Sizes: 10", 15", or 20" long.

LC-10 Light Safety Curtain - If funnels are removed, APPI highly recommends the addition of this option to prevent injuries. This option, when activated, prevents inputs to valves which causes the seal bar to activate. Additionally, the stepper motor stops when blocked.

FS-10 Flat Seal Assembly - Helps decrease / eliminate wrinkles in the seal by pulling sides of bag. Increase bag integrity.

TS-10 Trim Seal Assembly - Trims excess film from bag above seal to enhance the appearance of the package (retail products).

PB-20 Dual Palm Buttons - Decrease the possibility of injury to hands and fingers. Operator must push two buttons simultaneously to actuate seal bar.

Ti-1000 Thermal Transfer Inline Printer - Print bar codes, graphics, etc. by downloading pre-formatted labels, generated via label software. (PC or Terminal & software required)

Roll-a-Print 1400 or 2800 Single or Dual Thermal Inline Printer - Print bar codes, graphics on the front or both front and back of the bag, directly to the surface of the bag.

OFS-10 Output Fault Signal w/ SL-10 Stack Light - For automatic bagging operations with third party or production equipment, this signal provides a fault when the bagger is inoperative (due to out of bag conditions or other fault conditions).

Twin-Seal™ - Seal the bag a second time, 3/8" from the first seal for additional bag integrity.

Estop - This option can be used to stop the cycle operation of the T-1000 and possibly other auxiliary infeed or outfeed equipment if purchased with the T-1000.

CF-10 Counting Funnel - This option is useful to automatically cycle the bagger when a preset number of parts have fallen through the funnel.

AF-10 Accumulating Funnel - A special purpose funnel that collects and holds product until ready to be dropped, it can also insert a funnel to help contain the product.

BO-20 Bag-Open Detector - This option will detect whether or not a bag is blown open, or whether or not a funnel is inserted into the bag for validation that that bag is ready to receive product.

Bag-out sensor - If the bag material ends, a message will be displayed indicating out of bags or a threading or web breakage issue.

DF-10 Diverting Funnel - This feature is used to count bags from the bagger and divert them for further packaging operations including counting into cartons.

CS-10 Compartment Seal - seals the bag twice with compartments within the same bag.

MV-10 Seal Validation - additional components to provide a secondary means detecting a failure or out of range condition for components that affect seal quality.

BV-10 Barcode Verifier - to verify that a barcode is readable. If no barcode is detected, or if a barcode is not correctly formatted (as per software settings in the barcode verifier), then a NO READ message will be displayed.

BO-30 Bag Opening Device - This device enters the bag with one or more “fingers” and then pulls the bag open to a stop.

Base Height adjustment - electronic mechanism which raises or lowers the base of the bagger, which allows for more versatility and convenience, without this option the operator would raise or lower the bagger manually.

UF-2000 Takeaway Conveyor - Remove the packaged product to a packing station or directly feed a carton or table, conveying the product from floor level. The conveyor perfectly fits underneath the T-1000 and takes the product away. Small, lightweight and equipped with castors, use this conveyor anywhere in the plant. Designed for 24 hour / 7 days a week operation.

UF-5000 Infeed conveyor - Kit packaging infeed conveyor. Instead of loading parts directly into the Bag, load parts into compartments on the conveyor. Packaging kits loading the compartments by hand or automatically with parts or scales

UC-2400 Vibratory Parts Counter - Automatic parts counter feeds fasteners, electronic components injected molded parts and many other types of product, then drops the final count into the bag, carton or infeed conveyor.

US-4000 Check Weigh Scales - When you must guarantee the contents of the bags or kits, APPI Offers check weigh scales with incredible accuracy, speed and reliability, A history of weighments is standard along with job/recipe saves.

US-5000/7000/9000 Semi automatic (US-5000) or automatic scale (US-7000 &US-9000) feeds a weigh/counted batch of product into bags.

Other options may have been added since the date this list was printed. Please call for additional or Custom options pricing.

1.6 Using this Manual - Typographical Conventions

The following manual conventions are frequently used to assist in understanding important information, alerting the operator of potentially dangerous or damaging practices, and the normal functions of the T-1000 Advanced Poly-Bagger™.

text Normal text

<ENTER> Used to show Touch Screen keys

Italics Used for emphasis

CAUTION: Warning messages: To avoid physical harm, damage to equipment or damage to the product. Be sure to read these messages carefully.

1.7 Warranty Registration

(This section must be completed and returned to Advanced Poly Packaging, Inc. to register the T-1000 for Warranty Protection)

T-1000 Serial Number:

_____ (Serial Number located on the back panel)

Company Name & Address

Contact Name(s) / Title(s) / Phone Number

_____	_____
_____	_____
_____	_____
_____	_____

Please fax or mail this page to:

Stuart Baker
Advanced Poly-Packaging, Inc.
1331 Emmitt Road
Akron, OH 44306
USA

Fax # (USA) 330-785-4010

Chapter 2, Getting Started

Installation Procedures

Assembly Instructions

Height Adjustment

Air & Power Hookup

Bag Threading

Cycle Operation

2. Getting Started

This chapter describes in detail procedures to receive and setup the T-1000, including uncrating, environmental, air and power requirements, assembly, and height adjustments. Additionally, this chapter describes how to turn on power to the T-1000 and properly thread bags through the machine.

2.1 Installation Procedures

The T-1000 is transported as a single unit in a custom crate designed to protect the machine during shipment. It is shipped completely assembled except for a few items which are easily attached during installation with final adjustment for proper placement of touch screen, dancer assembly, foot switch, funnel and guards.

Unpacking: After removing the stretch wrapping, remove the outer crate from the skid which contains the T-1000. Unfasten the base support brace from the skid. Carefully lower the T-1000 from the skid. Transport the T-1000 to the operating location prior to placing the Touch Screen in position and unfastening the dancer assembly.

Operating Environment: The T-1000 should be placed in an area free of excessive heat, moisture, dirt and dust. Operating room temperature should range from 50 to 100 degrees Fahrenheit.

2.2 Air & Power Requirements

Power Requirements: Provisions must be made for 115 VAC, 50/60 Hz line current with ground. Full Load Current for T-1000: 12 AMPS.

CAUTION: A qualified electrician should ensure that the T-1000 power outlet is properly grounded, voltages are as required and amperage capacity is sufficient. Note: APPI recommends a dedicated 20 Amp circuit for the T-1000.

Air Requirements: At least 2 CFM free air is required, regulated to 60 PSI. *Note: Air should be dry and oil-free.*

Note: Running the T-1000 at a higher PSI setting than 60PSI will cause excessive wear and may cause damage to components on the machine or parts being packaged. The antijam function may also be adversely affected.

2.3 Assembly Instructions

Choose an operating location considering traffic flow, availability of bag supplies, supply of product to be packaged, takeaway of finished packages, placement of auxiliary infeed equipment and placement of takeaway conveyor(s). Operating location, the first step is to remove any inner packaging, banding or wires.

Touch Screen Assembly/Position: The Touch Screen has been secured for transportation in a positioned "face in" with protective wrapping. Holding the Touch Screen preventing it from falling, loosen the set screw located in the clamp collar at the top of the upper "T" column. Pull the shaft from the clamp collar approximately 6" and tighten the collar. Holding the Touch Screen module, loosen the "ball" clamp lever and position the touch screen. (Fig 2-1).

CAUTION: To avoid damage to the Touch Screen module, hold the Screen until it is in the desired position and then be sure the screws and ball clamp lever are securely tightened.

Dancer Assembly: The dancer assembly, located on the stand at the rear of the T-1000, is secured with tape strapping during shipment. After the removal of the strapping, the dancer should be checked to make sure that it will rotate freely in a semicircular path. The shaft assembly may then be inserted into

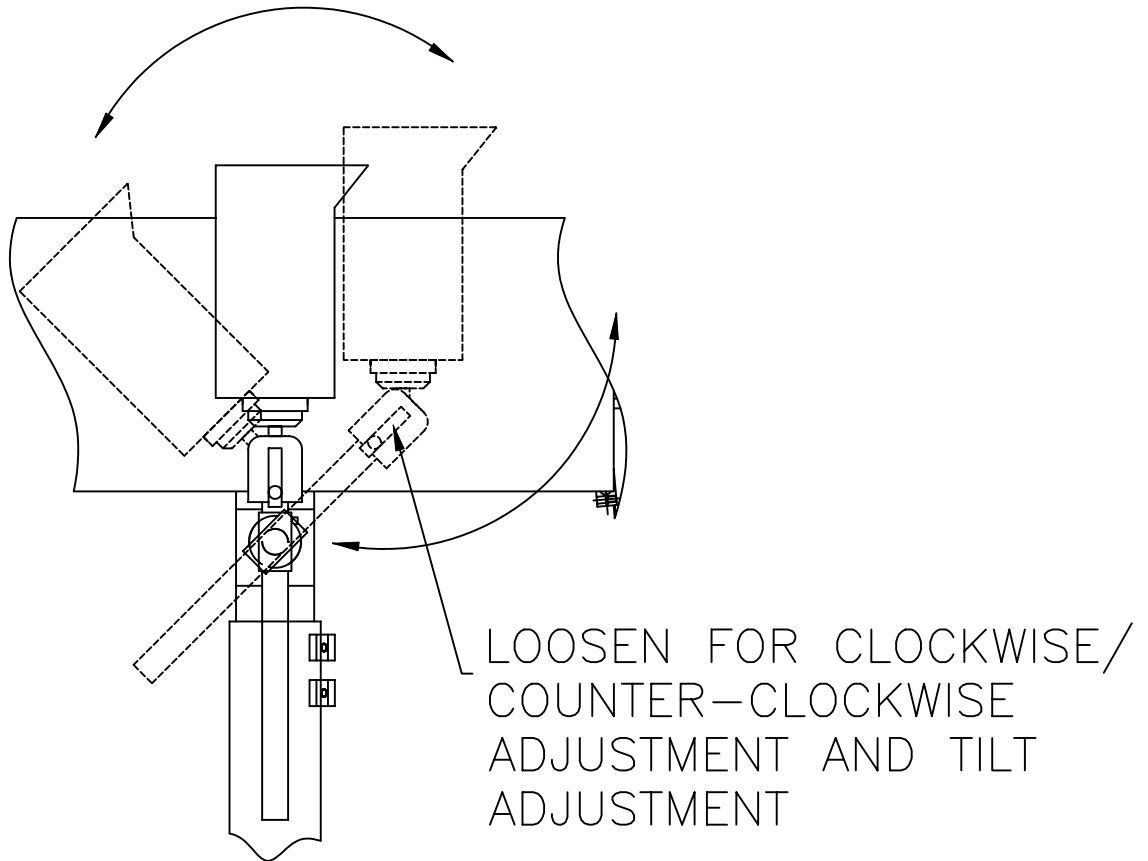
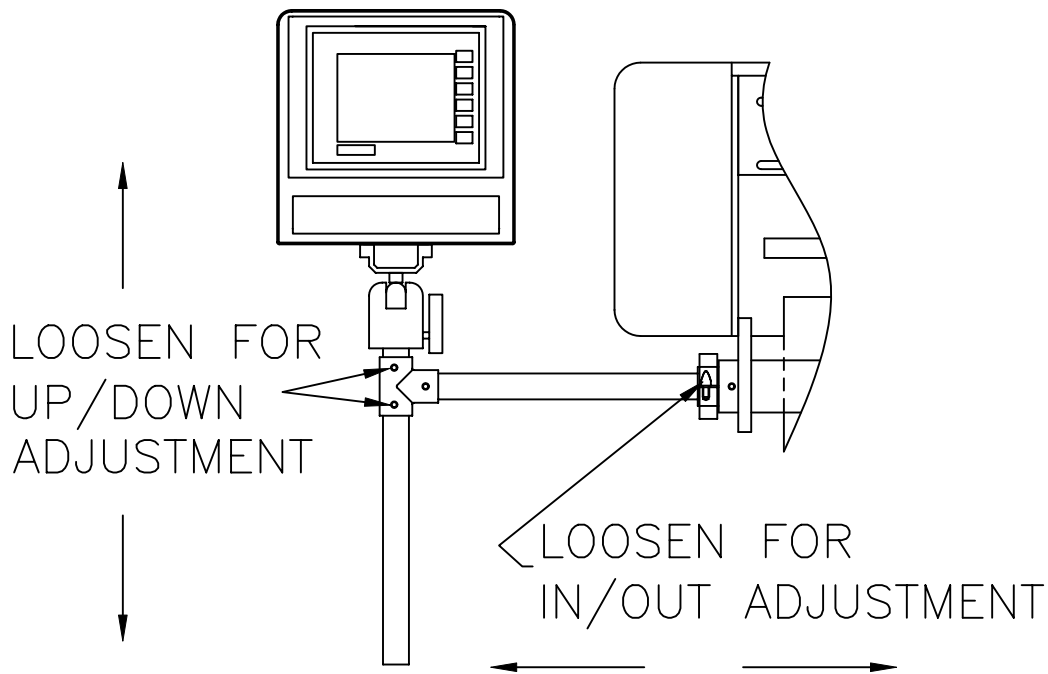

QUANTITY	—	FIGURE 2-1		
MATERIAL	—	 Advanced Poly Packaging Inc. <small>1331 Emmit Road • Akron • Ohio 44306 Phone: 330-785-4000 • Fax: 330-785-4010</small>		
FINISH	—	TYPE EQUIPMENT	B/W REF. NO.	PART NO.
TOLERANCES UNLESS OTHERWISE NOTED: +/- .015 ON FRACTIONAL DIMENSIONS +/- .010 ON TWO PLACE DECIMAL DIMENSIONS +/- .003 ON THREE PLACE DECIMAL DIMENSIONS 125 ✓ ON MACHINED SURFACES ALL DIMENSIONS ARE IN INCHES PART MUST BE FREE OF BURRS AND SHARP EDGES		T-1000		—
		SCALE	DRAWN BY	APPROVED
		1:3	NAME MELODY	NAME
			DATE 12/13/01	DATE
NOTICE: THIS DOCUMENT CONTAINS PROPRIETARY INFORMATION AND IT SHALL NOT BE USED OR REPRODUCED OR ITS CONTENT DISCLOSED, IN WHOLE OR PART, WITHOUT THE PRIOR WRITTEN CONSENT OF ADVANCED POLY-PACKAGING INC.		TITLE	DRAWING NO.	REV.
		I.O.P ASSEMBLY & POSITION	TP-T1D01	—

the dancer frame brackets so it is over the brake stop for tension. The dancer should be checked to insure that it rotates freely.

CAUTION: Seal bar should not come in contact with the funnel during sealing. Raise the funnel to avoid contact.

CAUTION: To avoid injury, do not operate the T-1000 without a funnel, guard or covers properly positioned.

CAUTION: APPI offers a variety of funnels and chutes. You may need to add guarding to prevent operators from reaching in, around or under the guard or funnels.

CAUTION: To avoid injury, do not reach underneath guards while the machine is plugged in.

Machine Height Adjustment: The height of the T-1000 is adjustable. To change the height of the machine, three (3) people total are required. With two people holding the weight of the machine, loosen the two bolts located on the leg, clamping the outer leg to the inner leg (Fig 2-4). Raise or lower the T-1000 to the desired height, and tighten the two bolts.

CAUTION: Unless properly supported the T-1000 will drop suddenly when loosening the height adjust bolts. This may cause damage to the machine or injury to individuals.

CAUTION: Do not attempt to adjust the height without the assistance of at least two other people supporting the weight.

2.4 Air & Power Hookup

This section describes in detail how to hook up air and power and the air and power requirements.

Note: A qualified electrician should ensure power outlets are the required 115 VAC and properly grounded before hooking up the power.

The air supply should be fed to the T-1000 with 3/8 ID flexible tubing; this tubing affixes to the coupler adapter (quick disconnect not provided). Connect the air to the regulator by holding the regulator firmly in one hand and pushing the air line connector on the male regulator connector. After connecting air, the regulator should be adjusted so the gauge reads 60 PSI. Insert the T-1000 power cord into a 115 VAC, 50/60 Hz, grounded power outlet.

2.5 Main Power

The main power switch is located on the rear panel (Fig. 2-5). Press the switch to ON position so that the Red main power light is illuminated. When the power is in the ON position, the Touch Screen will power up displaying the Introduction Screen. The program version will also be identified. The introduction screen will only appear for a few seconds until automatically changing to the Operation Screen or Main Menu. *Note: If the Touch Screen does not power up to the Introduction "T-1000" screen, see Chapter 7, Trouble- shooting steps.*

2.6 Bag Threading (Fig. 2-6 & 2-7, Threading Diagrams)

The first step to threading the machine is to place a roll of bags on the shaft. Remove one of the chucks from the shaft by loosening the chuck knob and slide the roll of bags over the shaft, locking the chuck pin in the small hole in the core plug. Tighten the knob. Replace the second chuck also locking the chuck pin to the core plug. Remove the tape from the bags so that the bags fall freely and hang down from the top of the roll towards the back of the machine. Insert the right side of the roll shaft in the right side of the shaft holder (circular holder). Then drop the roll shaft in the slot located on the left side of the dancer assembly.

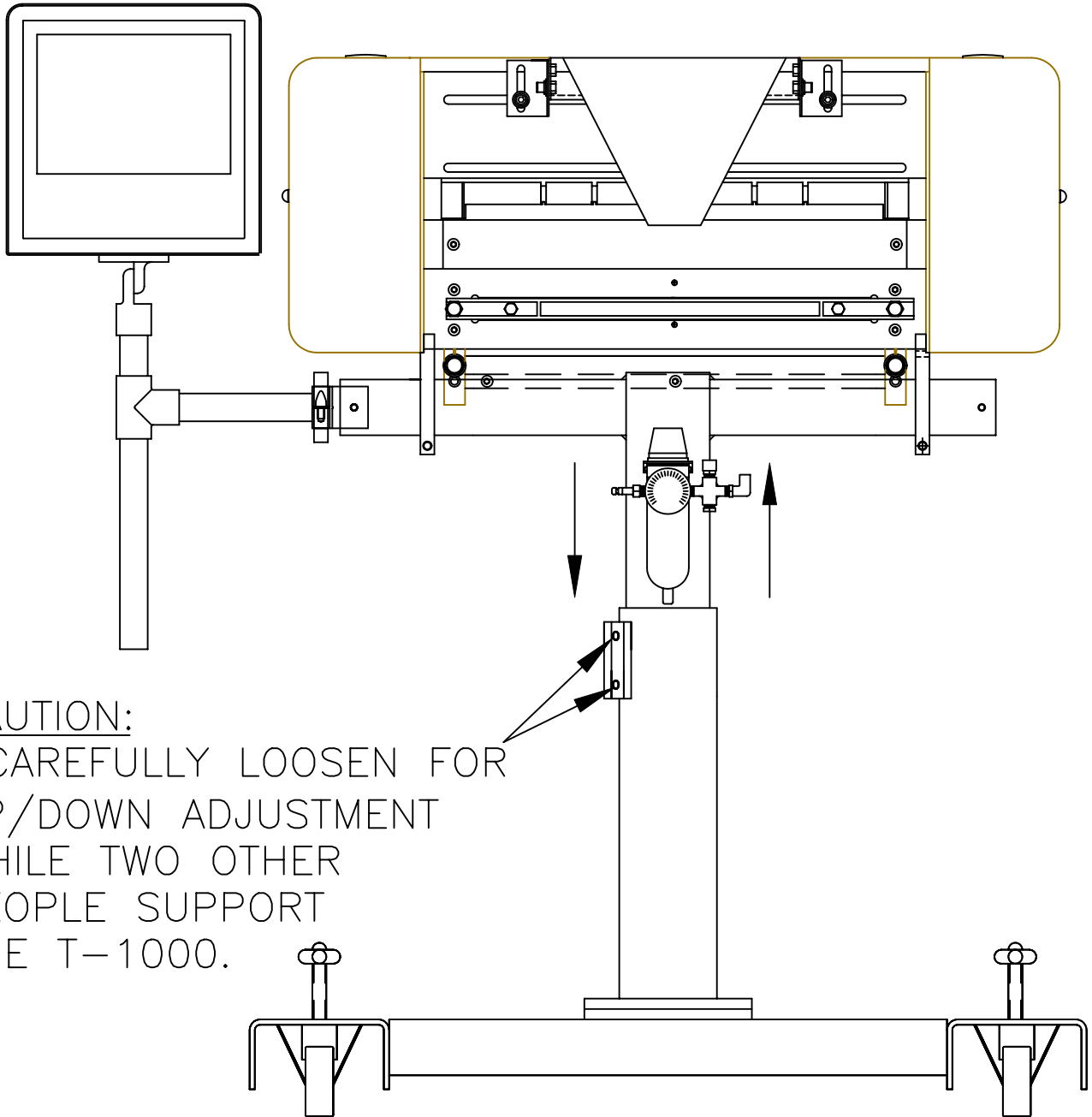

CAUTION:
 CAREFULLY LOOSEN FOR
 UP/DOWN ADJUSTMENT
 WHILE TWO OTHER
 PEOPLE SUPPORT
 THE T-1000.

CAUTION:
 DUE TO THE WEIGHT OF BAGGER,
 MACHINE MAY DROP SUDDENLY AND MAY
 CAUSE SEVERE INJURY, IF NOT HELD IN
 POSITION BY TWO PEOPLE.

QUANTITY	-
MATERIAL	-
FINISH	-
TOLERANCES UNLESS OTHERWISE NOTED: +/- .015 ON FRACTIONAL DIMENSIONS +/- .010 ON TWO PLACE DECIMAL DIMENSIONS +/- .003 ON THREE PLACE DECIMAL DIMENSIONS 125 ✓ ON MACHINED SURFACES ALL DIMENSIONS ARE IN INCHES PART MUST BE FREE OF BURRS AND SHARP EDGES	
NOTICE: THIS DOCUMENT CONTAINS PROPRIETARY INFORMATION AND IT SHALL NOT BE USED OR REPRODUCED OR ITS CONTENT DISCLOSED, IN WHOLE OR PART, WITHOUT THE PRIOR WRITTEN CONSENT OF ADVANCED POLY-PACKAGING INC.	

FIGURE 2-4		
 Advanced Poly Packaging Inc. <small>1331 Ewett Road ■ Akron ■ Ohio 44306 Phone: 330-785-4000 ■ Fax: 330-785-4010</small>		
TYPE EQUIPMENT	B/M REF. NO.	PART NO.
T-1000		-
SCALE	DRAWN BY	APPROVED
1:3	NAME MELODY	NAME
	DATE 12/13/01	DATE
TITLE	DRAWING NO.	REV.
MACHINE HEIGHT ADJUSTMENT	TP-TC01	-

LEFT PANEL

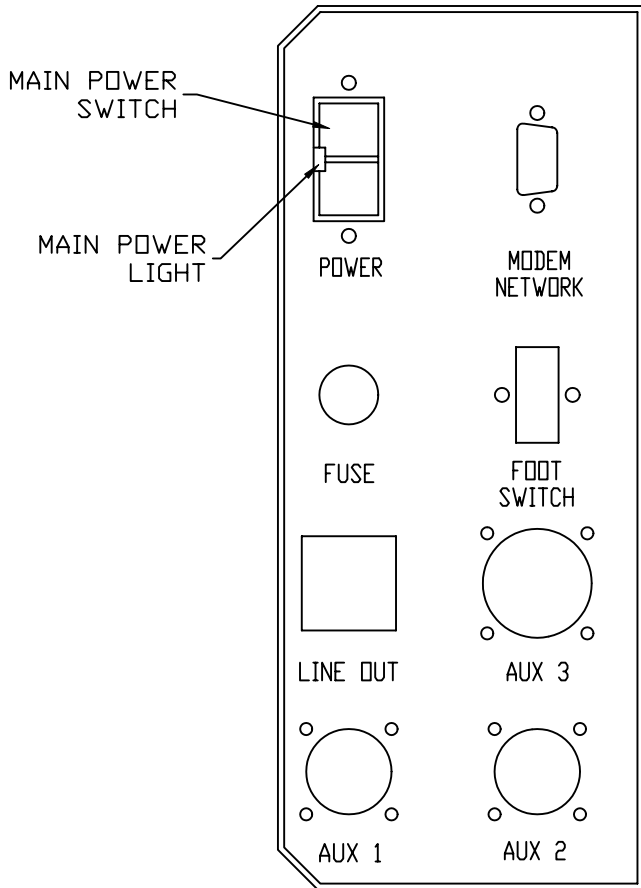

FIGURE 2-5



Advanced
Poly Packaging Inc.

1331 Emmitt Road * Akron * Ohio 44306
Phone: 330-785-4000 * Fax: 330-785-4010

TYPE EQUIPMENT T-1000		B/M REF. NO.	PART NO.
SCALE 1:2		DRAWN BY NAME MELODY DATE 12/4/01	APPROVED NAME DATE
TITLE ELECTRICAL & PNEUMATICS BACK PLATES		DRAWING NO. TP-T1E04	REV.

NOTICE: THIS DOCUMENT CONTAINS PROPRIETARY INFORMATION AND IT SHALL NOT BE USED OR REPRODUCED OR ITS CONTENT DISCLOSED, IN WHOLE OR PART, WITHOUT THE PRIOR WRITTEN CONSENT OF ADVANCED POLY-PACKAGING INC.

USE THIS DIAGRAM FOR LONGER BAG LENGTHS

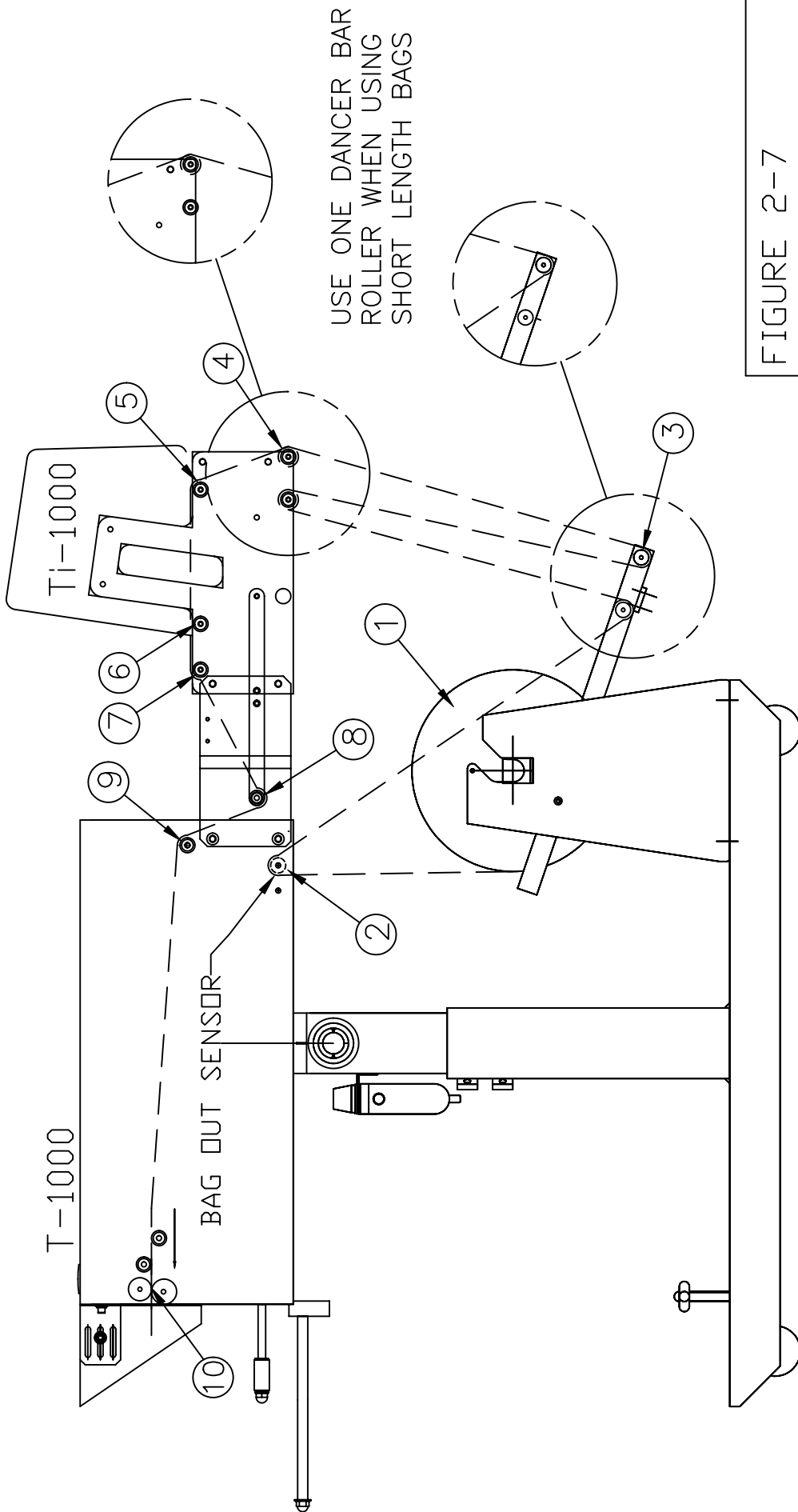
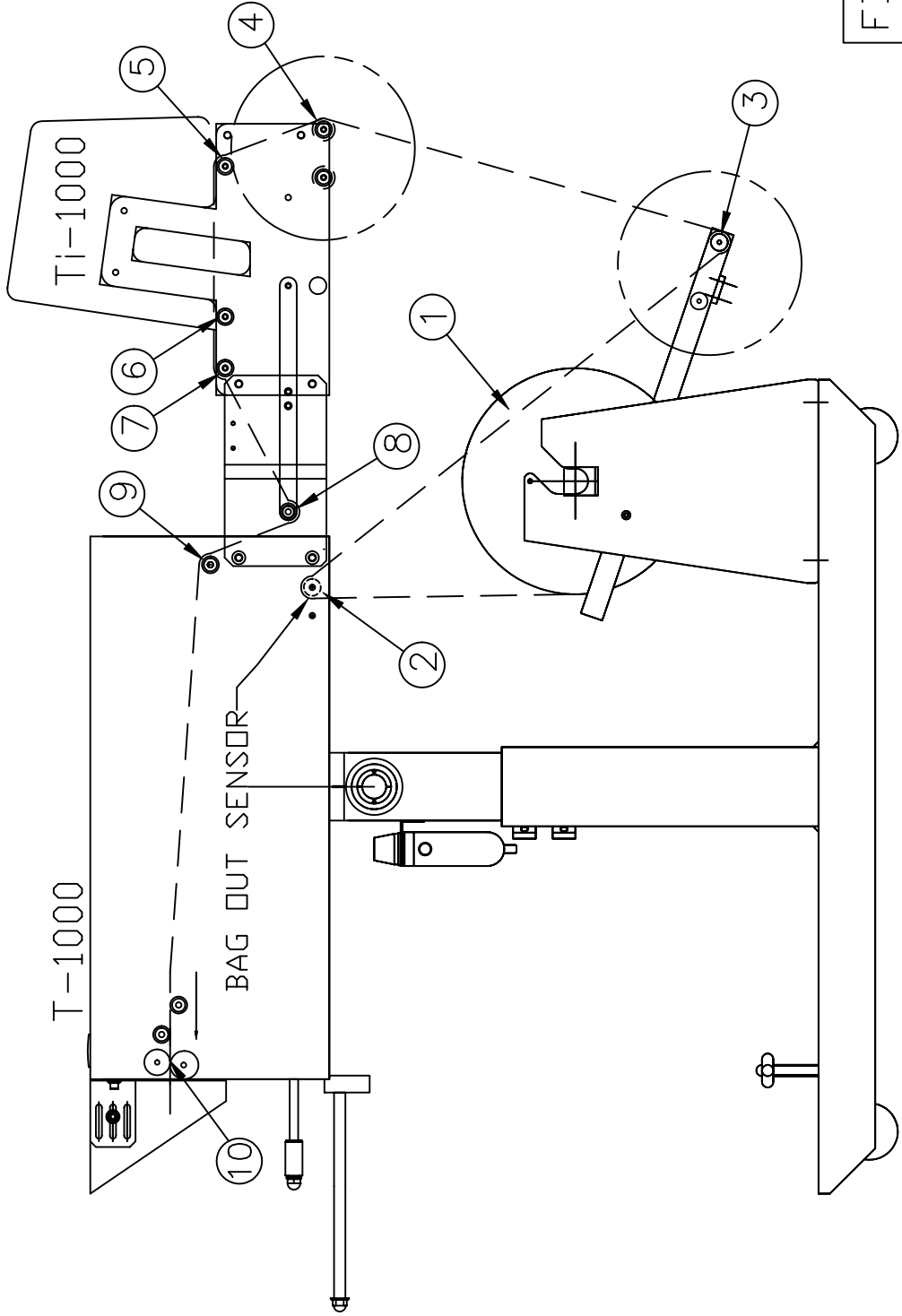

FIGURE 2-7

		Advanced Poly Packaging Inc. 1524 E. Highway Road • Aurora • OH 44202 Phone: 330-233-8000 • Fax: 330-233-0010	
TYPE EQUIPMENT		PART NO.	
SCALE	DRAWN BY	APPROVED	
1:4			
	NAME	MELODY	NAME
	DATE	12/04/01	DATE
TITLE		DRAWING NO.	
THREADING		TP-11T02	
DIAGRAM		REV. B	

NOTES: THIS DOCUMENT CONTAINS PROPRIETARY INFORMATION. IT IS THE PROPERTY OF ADVANCED POLY-PACKAGING INC. AND IS NOT TO BE REPRODUCED OR DISCLOSED IN WHOLE OR IN PART WITHOUT THE PRIOR WRITTEN CONSENT OF ADVANCED POLY-PACKAGING INC.

USE THIS DIAGRAM FOR SHORTER BAG LENGTHS



USE BOTH DANCER BAR
 ROLLERS WHEN USING
 LONGER LENGTH BAGS

FIGURE 2-7

		Advanced Poly Packaging Inc.	
1524 E. Highway Road • Marion • OH 43052 Phone: 614-392-3000 • Fax: 614-392-7852-010		PART NO.	
TYPE EQUIPMENT		DRAWN BY:	
SCALE: 1:4		APPROVED:	
NAME:		MELODY:	
DATE: 12/04/01		DATE:	
TITLE: THREADING DIAGRAM		DRAWING NO.: TP-11T02	
REV. C		REV. C	

NOTES: THIS DOCUMENT CONTAINS PROPRIETARY INFORMATION. IT IS THE PROPERTY OF ADVANCED POLY-PACKAGING INC. AND IS TO BE KEPT CONFIDENTIAL. IT IS TO BE DISCLOSED IN WHOLE OR IN PART WITHOUT THE PRIOR WRITTEN CONSENT OF ADVANCED POLY-PACKAGING INC.

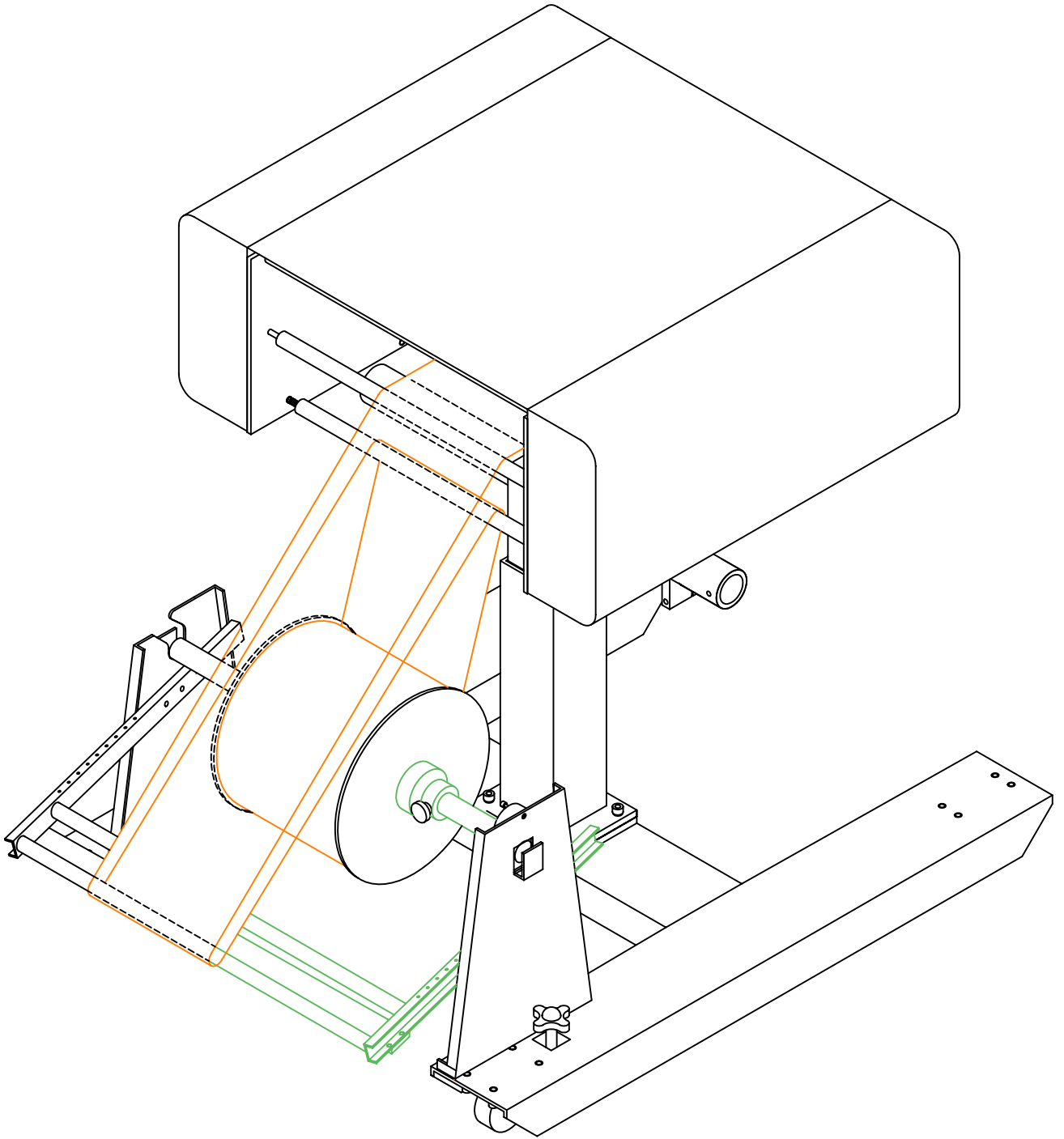

BACK VIEW

QUANTITY	-	FIGURE 2-9			
MATERIAL	-	 Advanced Poly Packaging Inc. <small>1225 Everett Road • Akron • Ohio 44306 Phone: 330-795-3999 • Fax: 330-795-3999</small>			
FINISH	-	TYPE EQUIPMENT	D/W REF. NO.	PART NO.	
TOLERANCES UNLESS OTHERWISE NOTED +/- .005 ON FRACTIONAL DIMENSIONS +/- .010 ON TWO PLACE DECIMAL DIMENSIONS +/- .015 ON THREE PLACE DECIMAL DIMENSIONS .015 ON PROPOSED SURFACES ALL DIMENSIONS ARE IN INCHES PART MUST BE FREE OF BURRS AND SHARP EDGES		T-1000		-	
NOTED: THIS DOCUMENT CONTAINS PROPRIETARY INFORMATION AND IT SHALL NOT BE USED OR REPRODUCED OR ITS CONTENT DISCLOSED, IN WHOLE OR PART, WITHOUT THE PRIOR WRITTEN CONSENT OF ADVANCED POLY-PACKAGING INC.		SCALE	DATE	DATE	DATE
		1:3	12/04/01		
		TITLE	DRAWING NO.	REV.	
		BAG THREADING LOWER FRAME	TP-2-9	-	

Center the bags on the shaft by loosening the chuck knobs and sliding the roll of bags along with the chucks to the desired location. Ensure the chuck pins remain in the core plug holes when sliding left or right. Pull the bags over the roller immediately above the dancer assembly, then down between the roll of bags and the outer dancer roller. Pull the bags around the outer dancer roller, over the rear "guide" roller and into the back of the T-1000. Push the bags at least half way through the machine.

From the front of the T-1000, lower the frame by slowly pulling the frame handle forward and downward while holding the guard assembly, supporting the weight of the seal frame assembly. See Fig. 2-9.

CAUTION: You must support the weight of seal assembly while lowering it with the handle. Otherwise, you may drop the seal assembly possibly causing personal injury or damage to the equipment.

Carefully reach inside and pull the bags through the front of the T-1000 so that one bag is centered on the roller. Ensure only one (1) bag extends through the front of the machine. Slowly raise the frame by pulling forward and upward on the handle while holding the bag in position. Holding the guide roller shaft, slide the Roller Guides within approximately 1/8" from the sides of the bag to assist the tracking of the web of bags.

Caution: Roller "Fingers" may be sharp. To avoid injury when reaching into the T-1000, ensure that you do not come in contact with the roller "fingers."

Note: The Roller Guides are for fine adjustments only, after proper tracking has been achieved. If the web of bags are not properly tracking, make proper adjustments. If not tracking properly, the web of bags may "ride" up the side of the guides causing the bags to fold over.

2.7 Cycle Operation of the T-1000

If all prior installation procedures have been performed properly, the T-1000 should be in its operating location with air and power connected. All guards, funnels and covers should be in position and securely fastened.

Locate the foot switch and plug the foot switch in the rear foot switch connector (Fig. 2-5). Press the foot switch to index one bag through the "nip" rollers. One bag should index, blow open and stop between the pressure bar and the heater bar. If the T-1000 is not up to temperature, the machine will not cycle unless the <Run> button is toggled to the Setup position.

If the web of bags breaks prematurely, further adjustments will be required. See Chapter 7, Trouble shooting. If one bag indexed through the machine, press the foot switch a few times more. Each previously indexed bag should detach completely from the web of bags. If the bag is not indexing and/or stopping or not tearing off properly, see Chapter 7, Trouble shooting.

Note: Web of bags may track right or left for a few feet until "settled" on the web path. The roll of bags or the roller guide may require readjustments or realignment after the first few feet of bags are indexed.

Note: If bags were delivered with the T-1000 or the size of the bags were known to APPI, the T-1000 may be ready to run. Therefore, few changes to BAG SET UP may be required.

2.8 Note on Adjustments to the T-1000

Upon receipt, it is not unusual for the T-1000 to be out of alignment due to shipping and excessive handling. Unless physically damaged, the T-1000 will function properly after minor adjustments are accomplished. Read Chapter 4 for information on adjustments of the T-1000.

This page intentionally left blank.

Chapter 3, Touch Screen Operation

Touch Screen Part Names

Specifications

Contrast Adjustment

Touch Screen Program

3. Touch Screen Operation

This section describes in detail, the identification, operation and adjustments of the Touch Screen Program.

3.1 Touch Screen Part Names - Front Panel (See Fig. 1)

- 1 System Button (See Section 3.4)
- 2 F1 (Help Screen)
- 3 F2 Increase Brightness (when system button is pressed)
- 4 F3 Midpoint Brightness (when system button is pressed)
- 5 F4 Decrease Brightness (when system button is pressed)
- 6 F5 Job Save / Recall
- 8 Green LED (Power): Lit when Touch Screen is turned on

3.2 Touch Screen Part Names - Back Panel (See Fig. 2)

- 1 RS-232 Communication port to PLC
- 2 Programming (For APPI use only).
- 3 Power Supply: Power terminal for Touch Screen Operation.

3.3 Touch Screen Specifications/Features

Power: 24 VDC (+/- 10%)

Operating Environment: 0-50 degrees C, 85% RH or less

Display: Color LCD

Resolution (W x H (dots)): 320 x 240

Display area (mm): 115.2 x 86.4 (5.7")

Backlight: CCFL

Backlight Hours: approx. 50,000

Life of touch panel: 1,000,000 touches or more

PLC connection: RS232

Number Characters: 40 char. x 30 lines max.

3.4 Touch Screen Contrast Adjustment

The contrast of the LCD may be adjusted if the screen is difficult to read. To adjust the contrast, press the <System> button located to the right side of the active touch screen area (See Fig. 2). Then press the F2 button to increase brightness and the F4 button to decrease brightness. F3 will go to the midpoint position.

3.5 Touch Screen Program

The Touch Screen Program is a "user-friendly" menu-driven setup and operation program. Popup windows are incorporated for quick and easy setting adjustments. Each time a setting is changed, the settings are saved so that if power is lost, the "job" will be recalled automatically without the need for reprogramming. Moving around through the program, entering menu levels and entering setup options are easily and quickly achieved by just one touch of the screen to set the options you choose. A general color scheme has been used for consistency with operation:

Blue: Background color. Blue is used as a background or text only color. Pressing this area will typically do nothing.

Yellow: Yellow buttons are Menu buttons which will take you to other available screens. Yellow buttons may be located anywhere on the screen.

Green: Setting button. Green buttons are used to change settings or mode of operation.

Red: Stop functions or warning messages.

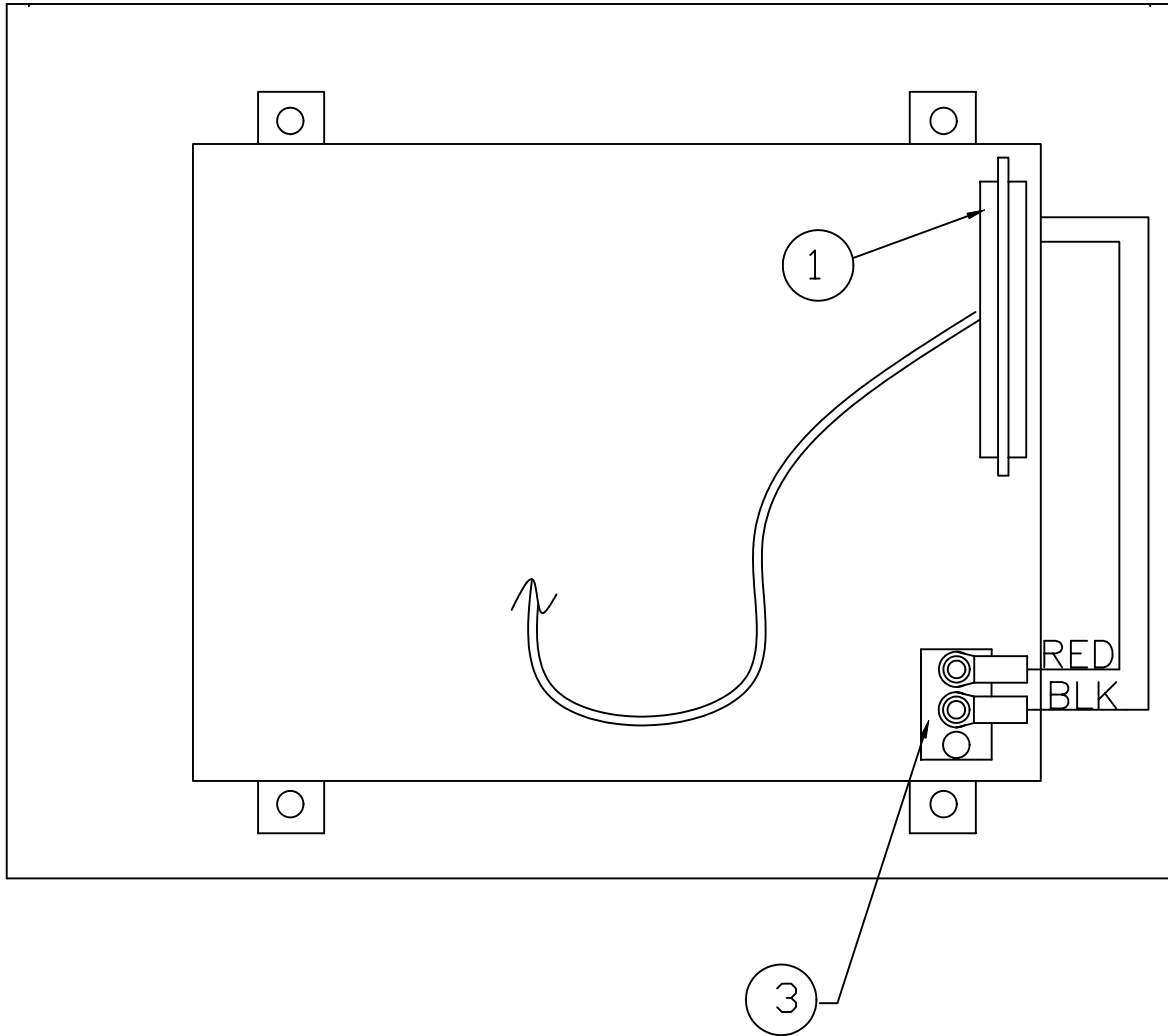

FIGURE 2



Advanced
Poly Packaging Inc.

1331 Emmitt Road * Akron * Ohio 44306
Phone: 330-785-4000 * Fax: 330-785-4010

TYPE EQUIPMENT T-1000		B/M REF. NO.	PART NO.
SCALE FULL		DRAWN BY NAME MELODY DATE 10/23/00	APPROVED NAME DATE
TITLE I.O.P REAR PANEL		DRAWING NO. TP-T1G03	REV.

NOTICE: THIS DOCUMENT CONTAINS PROPRIETARY INFORMATION AND IT SHALL NOT BE USED OR REPRODUCED OR ITS CONTENT DISCLOSED, IN WHOLE OR PART, WITHOUT THE PRIOR WRITTEN CONSENT OF ADVANCED POLY-PACKAGING INC.

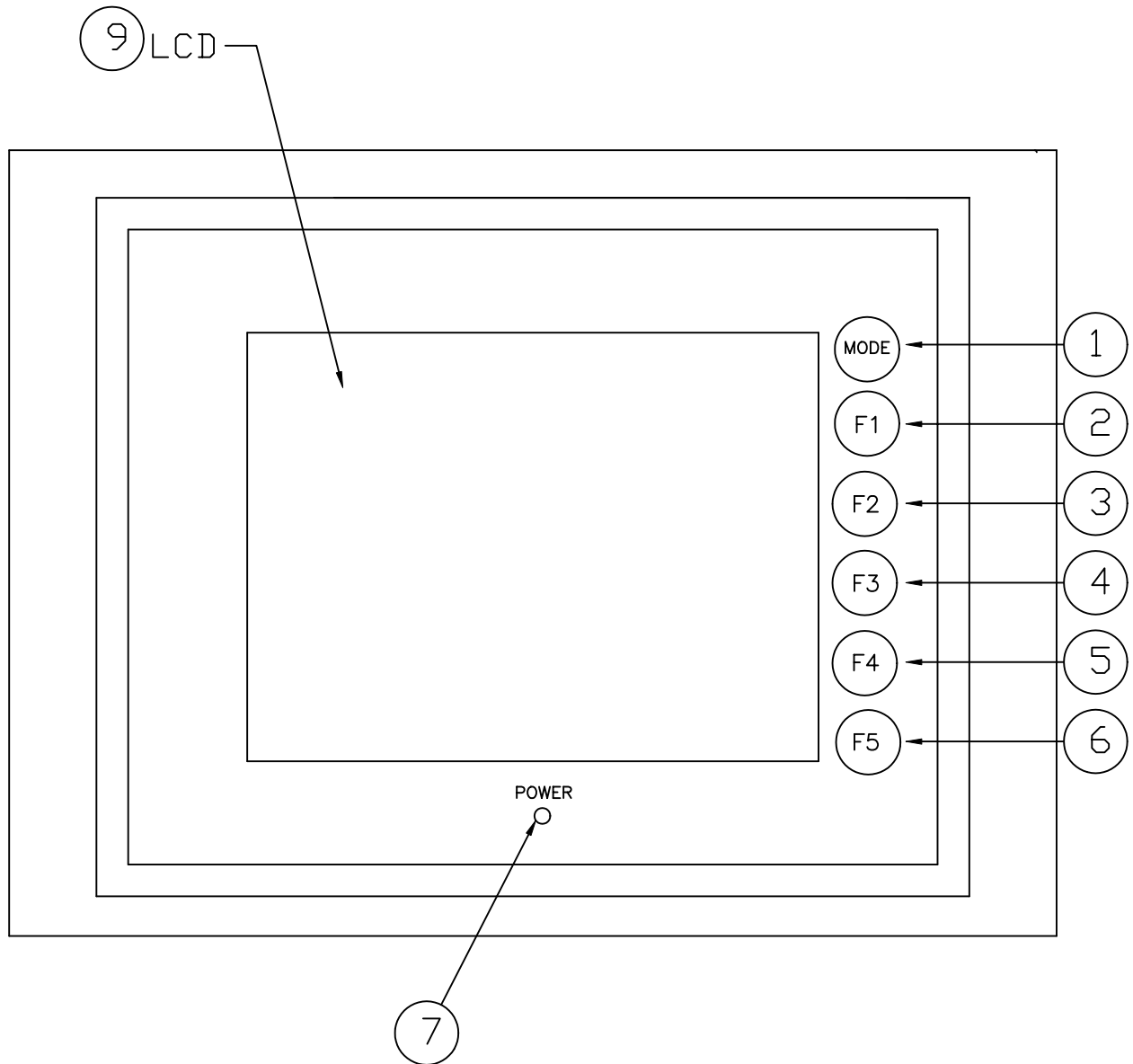

FIGURE 1



Advanced
Poly Packaging Inc.

1331 Emmitt Road * Akron * Ohio 44306
Phone: 330-785-4000 * Fax: 330-785-4010

TYPE EQUIPMENT T-1000		B/M REF. NO.	PART NO.
SCALE FULL		DRAWN BY NAME JLD DATE 5/2/06	APPROVED NAME DATE
TITLE I.O.P. FRONT PANEL & LEDS DIAGRAMS			DRAWING NO. TP-T1G02
NOTICE: THIS DOCUMENT CONTAINS PROPRIETARY INFORMATION AND IT SHALL NOT BE USED OR REPRODUCED OR IT'S CONTENT DISCLOSED, IN WHOLE OR PART, WITHOUT THE PRIOR WRITTEN CONSENT OF ADVANCED POLY-PACKAGING INC.			REV. A

3.6 Introductory Screen

When the T-1000 is turned on, an Introductory screen is displayed (Fig. 3-1). The Introduction screen is a welcome screen and has a button to take you to the Operations Menu.

3.7 Operation Screen

The Operation Screen is provided to function with Pass code Protection function of the machine. If the pass code function is enabled in the Technical Assistance Screen, the touch screen will default to the Operation Screen after a preset time has elapsed. This function prevents unauthorized operators from making setting changes that could affect the operation or performance of the unit. Since no settings are displayed on the Operations Screen, the operator cannot change settings unless a pass code is enabled. See Fig. 3-2

The Operation Screen also displays a Totalizing Counter and Production Time that can be reset by the operator.

Note: The Totalizing Counter feature must be turned ON from the Counters Screen to track cycle operations. See Fig. 3-18.

Note: For more information regarding the pass code function, refer to Section 3.28, Pass Code Setup, later in this chapter.

3.8 Main Menu

The Main Menu (Fig. 3-3) is initially accessed from the Operations Screen, This screen allows the operator to go through all of the screens.

Start / Stop button controls operation mode; mode which enables T-1000 to cycle.

Manual/Auto: Toggle button to enter Automatic (paced rate) or Auxiliary Cycle mode.

Pause/Setup: Temporarily deactivates Predetermining Counter and Totalizing Counter until reset.

Temporarily deactivates signal to auxiliary equipment. Allows cycle operation when heater bar is not up to temperature.

Ready/Waiting: Indicator LED. Displays Ready when heater bar is at the temperature set point. Waiting flashes when the machine is not at temperature.

3.9 Bag Setup Menu

The Bag Set Up Menu prompts the operator to input bag timer settings which change seal point, temperature, fill time (paced rate) and air pulse time. Bag thickness, length, width and product characteristics affect these settings. Once set, the operator may save the bag settings along with options settings and auxiliary settings for later recall (Fig. 3-4). All settings will be entered numerically on a keypad, See Fig. 3-5.

The bag set up menu is the menu where most entries and machine operation setting will occur. When a new bag size or thickness is introduced, the T-1000 must be *set up* to properly run the bags.

3.10 Fill Time

The <Fill Time> button functions differently dependent upon the MODE in which the T-1000 is operating: 1) MANUAL, 2) AUTOMATIC (<AUTO>) mode or AUXILIARY mode.

1) In the Manual mode with NO accumulating funnel, Fill Time will delay the operation from starting until this time has passed. When the T-1000 is equipped with an accumulating funnel, Fill Time will affect the delay time before sealing, after the door has closed on the accumulating funnel.



Fig. 3-1

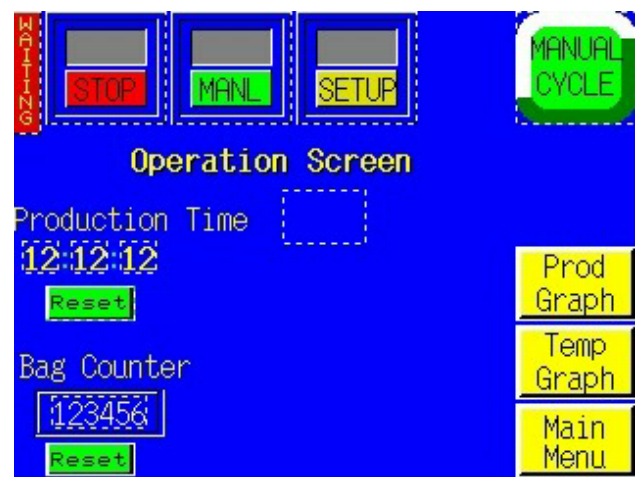

Fig. 3-2

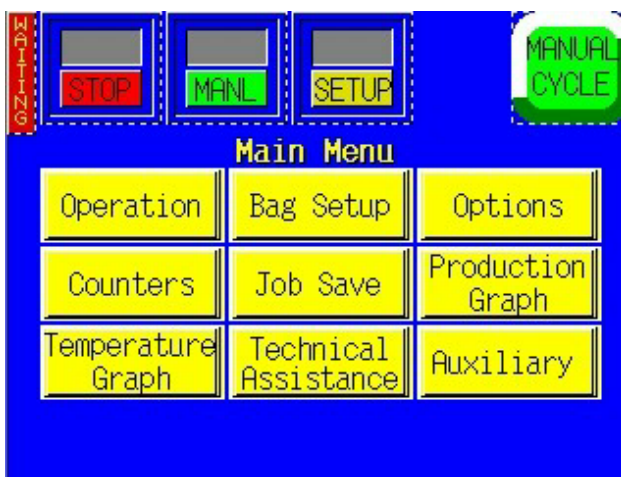

Fig. 3-3



Fig. 3-4

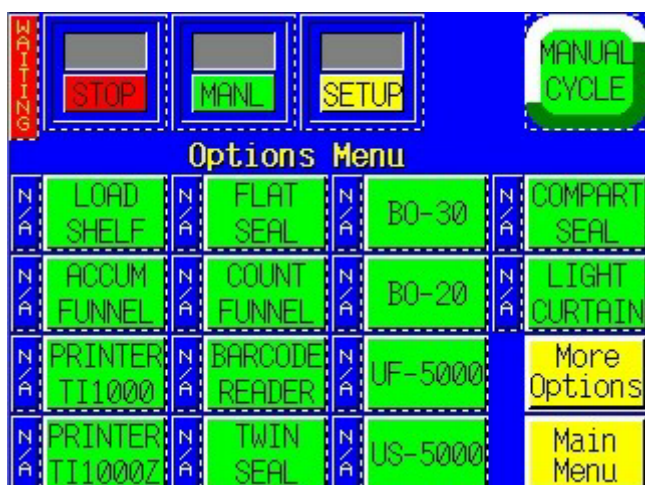

Fig. 3-5

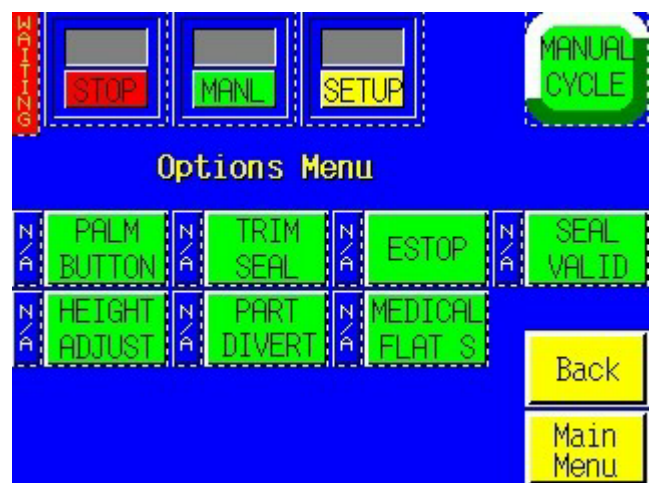

Fig. 3-6

LOAD SHELF (LSx-10)

We have a variety of Load Shelves to meet your packaging needs. The primary purpose of the Load Shelf is to support and settle heavy and bulky products.

LS-10: Flat Load Shelf
 LSC-10: Concave Load Shelf
 LSV-10: Load Shelf Vibration Kit
 LSL-10: Load Shelf Lift Kit

Activate Option Station Set-Up Option Menu

Fig. 3-7

LOAD SHELF (LSx-10)

STOP MANL SETUP MANUAL CYCLE

Load Shelf Setup

Shelf Down 1.23 s

OFF

Valve# 12

Return

Fig. 3-8

FLAT SEAL (FS-10)

The Flat Seal option helps to decrease or eliminate wrinkles in the seal by pulling the sides of the bag taut. Additionally, the FS-10 increases bag seal strength.

Activate Option Station Set-Up Option Menu

Fig. 3-9

FLAT SEAL (FS-10)

STOP MANL SETUP MANUAL CYCLE

Flat Seal Setup

OFF SETUP

Valve# 12

Return

Fig. 3-10

TRIM SEAL (TS-10)

When activated, the Trim Seal option trims the excess film from the top of the bag to enhance the appearance of the final package. Excellent for retail products.

Activate Option Option Menu

Fig 3-11

TRIM SEAL (TS-10)

STOP MANL SETUP MANUAL CYCLE

Trim Seal Setup

OFF

Seal Time 1.23 s	Blow Off 1.23 s
Cool Time 12.34 s	Seal Temp 123 °F

123 °F

Return

Fig. 3-12

2) In the AUTO cycle mode with no auxiliary infeed equipment, Fill Time affects the paced rate operation. The bagger will automatically cycle with the Fill Time delaying the seal bar after the bag has been blown open. In the AUTO mode, no foot switch or other actuator is used. *CAUTION: To avoid physical harm, DO NOT cycle the T-1000 in the AUTOMATIC mode when funnel(s), guard(s) or covers are removed. Caution: Since the seal bar actuates automatically, operators must keep fingers, hands and other parts of the body well away from the sealing mechanism and all other moving parts at all times.* AUXILIARY cycle mode, FILL TIME displays, in seconds, the time for which a product, automatically filled by auxiliary equipment, has to be completely settled in the bag before the seal bar is actuated. This time is typically referred to as the DELAY TIME.

CAUTION: To avoid physical harm, DO NOT cycle the T-1000 in the AUXILIARY mode without the funnel(s), funnel extension(s), guard(s) and covers in proper position. Since the seal bar actuates automatically, operators must keep fingers, hands and other parts of the body well away from the sealing mechanism and all other moving parts at all times.

To adjust the value, press the highlighted <Fill Time> button to display the number keypad. Then enter the value on the number keypad followed by the <Enter> button to return to the Bag Setup Screen.

NOTE: Auxiliary mode is further described in Appendix B, if Auxiliary options or components were provided by APPI.

3.11 Air Pulse

Displays, in seconds, the amount of time that a burst of air will last, *initially* blowing the bag open. Wider bags and heavier gauge bags require a longer burst of air to initially open the bag. Narrower and thinner gauge bags require less air to initially open the bag. To adjust the value, press the <Air Pulse> button from the Bag Setup Menu to display the number keypad. Press the numbers on the keypad followed by the <Enter> button to return the Bag Setup Menu. Additionally, to increase the *volume* of air from the air pulse tubes, turn the Air Pulse valve counter-clockwise; turning the valve clockwise will decrease the volume of air. The Valves to adjust the air pulse air volume and blower air volume are located on the right lower side of the seal frame assembly.

Note: The volume of air set should be the minimum amount and duration required to consistently open the bag.

3.12 Seal Point

Displays, in inches, the seal point position measured from the top perforation. To adjust the value, press the button labeled <Seal Point> from the Bag Setup Menu. Using the displayed number keypad, press in the value for the amount desired followed by the <Enter> button. Press the foot switch to test the setting and adjust as required. The proper positioning of the seal on the bag varies due to bag size and product characteristics. Wider bags generally require greater sealing area than do narrower bags. Additionally, bags packaged with bulky products require greater sealing area than do bags packaged with thinner products.

<New Bag> button is used to start an internal program which calculates an average bag length. This information is required if a perforation is not detected, so that the bag will stop in the correct seal position. Bag length information is displayed, but may not exactly match the bag length due to mechanical tolerances in the equipment (ie: roller diameter fluctuations). It is only useful to compare one bag length to the next. If the variance is too great, a Feed Error message will be displayed.

Note: Feed errors are detected and displayed on the screen. See Fig. 3-100. Once a feed error occurs, the bagger will restart to calculate the bag length.

3.13 Seal Time

Displays, in seconds, the time the pressure (rubber) bar will remain touching the surface of the bag for proper sealing. Sometimes referred to as "dwell time", seal time is one of three critical components to obtain a strong seal (other critical factors include seal temperature and seal pressure). To adjust the Seal Time value, touch the highlighted <Seal Time> menu option to display a number pad. To change the setting, press the number (decimal point first, if less than 1) and then press <Enter>. To clear an incorrectly pressed value, press the highlighted <Clear> button and retype the correct value. Pressing <Enter> will return you to the Bag Setup Screen. Test and further adjust if necessary.

3.14 Reverse

Displays in inches the distance that the rollers will reverse the bag into the T-1000, while the pressure bar is gripping the bag, to separate the bag being loaded from the bag above. For wider bags, the reverse distance may need to be increased. A typical setting is between .5" and 1". To adjust the value, press the <Reverse> button from the Bag Setup Menu. Using the displayed number keypad, press enter the value followed by the <Enter> button. Press the foot switch or otherwise cycle the bagger to test the new setting.

3.15 Blow Off: To decrease the possibility of bags sticking to the PTFE, a blow off tube is provided as a standard feature. The blower tube is located in the center, immediately below the seal bar. Typically, the blow off time is set to .1 to .3 seconds.

3.16 Index Speed

Displays in inches per second the speed at which the bag will feed/index into position. For shorter bags, the speed can be significantly decreased (to 10"/Sec, for instance). For longer bags, the setting can be increased to the max. setting of 30"/Sec. A typical setting is between 15 and 25" per second. To adjust the value, press the <IndexSpd> button from the Bag Setup Menu. Using the displayed number keypad, press enter the value followed by the <Enter> button. Press the foot switch or otherwise cycle the bagger to test the new setting.

3.17 Seal Temperature

When the power is ON, the heater bar element receives electrical current. The PLC pulses electrical current to the element until the temperature setting is reached. Shorter pulses indicate maintaining the temperature. An amber indicator lamp illuminates on the Bag Setup Screen while the element is receiving current. The longer the light is illuminating, the longer the "pulse" of current and the further away from the temperature setting. If the temperature of the heater bar is not within a set range around the set point, "Waiting" will be flashed on the top left screen. To adjust the value, press the highlighted <Seal Temp> button to display the number keypad popup screen. Enter the value and press <Enter> to return to the Bag Setup Menu.

NOTE: After making adjustments, test the seal strength prior to beginning production. It is normal for the indicator light to illuminate (pulse) during operation. As the actual temperature approaches the set temperature, the pulses will get shorter and shorter. When the heater bar is up to temperature, the Waiting LED indicator will change to Ready. From a "cold" start, it takes approximately four minutes to reach the set temperature.

Note on Seal Quality

Quality seals are achieved by making adjustments to SEAL TIME, SEAL TEMP., SEAL POINT and by having the proper seal pressure.

Note: As an additional seal function, cool time may also be required for heavy or bulky products. If too hot, the seal may separate when the pressure bar releases the bag after sealing. Cool time is considered a factory setting and can be adjusted through the Technical Assistance Screens. (See Section 3.50).

Note: Ensure Regulator Pressure is set to 60 PSI.

If, after making necessary adjustments, seal quality remains insufficient, additional options may be purchased to enhance seal appearance, integrity or strength.

See Chapter 1 for description of available options: FS-10 Flat Seal Assembly, TS-10 Trim Seal Assembly, BD-10 Bag Deflator, LS-10 Load Shelf, Twin Seal option). Wider seal bars are also available to increase the consistency of seals.

Temp Graph Menu Option is also accessible from this screen. See Section 3.45 for more information regarding this screen.

3.18 Options Menu

Options that have been added to the T-1000 at the factory can be setup from the Options Screen. If options were not installed at the factory, then N/A (Not available) will be displayed to the left of each options button. Otherwise, the button will display ON or OFF. Fig. 3-5 and 3-6.

Note: If options are added in the field, a pass code is required to Enable use of the option. Contact APPI for pass codes. Options which have been purchased separately must be installed by APPI or by qualified maintenance personnel.

The following sections describe how to setup optional equipment on the T-1000. If your T-1000 is not equipped with these options, please disregard these sections. Most of the listed options are not standard and must be purchased separately.

3.19 LS-10 Load Shelf

This option is used as a support shelf for the product to avoid the bag from prematurely tearing off at the perforation when the product is inserted in the bag. The Load Shelf allows the product to drop onto the shelf relieving the pressure on the bottom of the bag. See Fig 3-7.

To turn ON the load shelf, press the <Load Shelf> menu option and press the <ON> button. The Load Shelf down time is the length of time the shelf is in the down position. Increase the time for longer bags. See Fig. 3-8.

Note: Valve # X indicates the Valve Station number assigned to this option. Valve #0 indicates that no valve is assigned to this option. The option will not operate unless a Valve Station number is assigned, other than 0.

3.20 FS-10 Flat Seal Assembly

The Flat Seal Assembly option is not included in the standard T-1000 package and must be purchased separately. Used to help decrease or eliminate wrinkles or folds when sealed, the Flat Seal Assembly can easily be attached. For products which require a high integrity bag, for retail products, bulky products or "air tight" packages, the Flat Seal Assembly is ideal. The Flat Seal Assembly, also called

"fingers", flattens the seal portion of the bag (two layers of poly) by pulling the sides of the bag away from the center. The fingers enter the bag immediately before the pressure bar presses the two layers of the bag together, against the front sealer plate. Pulling on the sides of the bag outward causes the layers to flatten, decreasing the possibility of folds. See Fig. 3-9

To turn the Flat Seal Assembly ON, press the <Flat Seal> button on the Options menu and toggle ON the ON/OFF button. Use the <Setup> button to make it easier to mechanically adjust the fingers along the front plate slots on the T-1000. Once the mechanical adjustment is complete, press <ON> and <AUTO> for normal operation of the flat seal assembly. In the Auto mode, the fingers will automatically extend into the bag immediately prior to the pressure bar sealing the bag. See Fig. 3-10.

Note: Valve # X indicates the Valve Station number assigned to this option. Valve #0 indicates that no valve is assigned to this option. The option will not operate unless a Valve Station number is assigned, other than 0.

3.21 TS-10 Trim Seal Assembly

The Trim Seal option is not included in the standard T-1000 package and must be purchased separately. Used to enhance the appearance of packaged products, the Trim Seal option removes the excess film (trim) from the bag, above the seal. The Blow-off time indicates the time, in seconds, which a blower will remove the excess film from the bag (trim-off time). The Trim Seal option is ideal for 1) retail products for enhanced appearance and 2) hanging products for reduction of "shelf" space. See Fig. 3-11

Note: To properly "trim-off" excess film, the bag length may have to be increased to provide the required finished bag size. We recommend trimming at least 1.5" of film from the bag.

Two functions are available for trimming: 1) seal through and blow off, 2) seal through, side shift heater bar and blow off. The first function is recommended and works for most trimming applications. It also reduces wear on the heater bar and cylinder. The second function adds an additional operation of side-shifting the heater bar. This function is required when trimming specialty films such as polypropylene.

Press the ON/OFF toggle button to enable and disable the operation of the Trim Seal option. Press the value on the keypad to increase or decrease the Blow off Time value (trim-off time). Seal Point, Seal Time and Seal Temp. buttons are also available on this screen which are the same settings button that are on the Bag Setup Screen.

To enable the side-shift function, press the toggle button to turn ON the side shift.

Adjust all values until bags are trimming consistently. See Fig. 3-12.

Note: Operating the TS-10 option may cause production to decrease due to the additional time required for sealing and trimming off the excess. The side shift option and normal trimming function increase maintenance required on the heater bar, PTFE and cylinders.

Note: Valve # X indicates the Valve Station number assigned to this option. Valve #0 indicates that no valve is assigned to this option. The option will not operate unless a Valve Station number is assigned, other than 0.

3.22 PB-20 Palm Buttons

The Palm Buttons option (Dual Palm Buttons) is not included in the standard T-1000 package and must be purchased separately. This option is used as a safety device to avoid personal injury by ensuring that fingers or hands are not in the seal area during the cycle operation of the T-1000. See Fig. 3-13.

Caution: To avoid personal injury, do not operate the T-1000 when funnels are removed. Advanced Poly-Packaging, Inc. recommends either the Palm Button or Light Screen options to safeguard operators.

The Palm Button option operates in lieu of a foot switch. Two buttons, positioned on opposite (left and right) sides on the top of the T-1000 covers, must be *pressed* or *touched* simultaneously to cycle the bagger. If both buttons are not pressed at the same time, or if one of the buttons are held while the other button is pressed, the T-1000 will not cycle. As an additional safety function, the Automatic cycle mode is disabled when the Palm Button option is turned ON. The foot switch input is also disabled when the Palm Button option is turned ON.

The Palm Button option will be enabled at the factory, if the option was purchased with the machine. Otherwise, contact APPI Service Dept. for instructions on how to enable this option.

3.23 LC-10 Light Curtain

The Light Curtain option is not included in the standard T-1000 package and must be purchased separately. This option is typically used as a safety device to avoid personal injury by ensuring that fingers or hands are not in the seal area during the cycle operation of the T-1000. See Fig. 3-14.

Caution: To avoid personal injury, do not operate the T-1000 when funnels are removed. Advanced Poly-Packaging, Inc. recommends either the Palm Button or Light Screen options to safeguard operators.

Caution: Do not attempt to reach under guards for any reason. This may defeat the safety feature of the LC-10 Light Curtain option. The Light Curtain only deactivates the motor and seal/pressure bar when enabled and when the light curtain beam is broken from above the seal bar. Reaching from underneath will place your hands or fingers in the seal area!

As an additional safety function, the Automatic cycle mode is disabled when the Light Curtain option is turned ON. However, the foot switch input is not disabled when the Light Curtain option is turned ON so if pressed the machine will cycle.

To enable the Light Curtain option, press the button labeled <Press to Enable>. Once enabled, you will not be able to disable the option without knowing the correct pass code. See Fig. 3-15.

The Light Curtain option can be used as a means of initiating the cycle operation of the T-1000. To cycle the bagger automatically after the light curtain sensing area is cleared, press the <Mode> toggle button to change from Safe to Auto.

Once in the Auto mode, the <Min Time> can be set to “debounce” the input signal. This means that the curtain must be blocked for at least this amount of time before the T-1000 will automatically cycle. A typical setting for the Min Time is .3 seconds.

Also, in the Auto mode, the <Fill Time> can be set to delay the cycle operation. For instance, if the mode is set to Auto and the Fill Time is set to 1 sec., the machine will cycle only after the operator has removed their hands and after 1 second has elapsed.

A Message toggle, if pressed to ON will cause a message to be displayed during the time that the light curtain area is blocked. The message tells the operator that the machine will automatically cycle when they remove their hands.



Fig. 3-13



Fig. 3-14

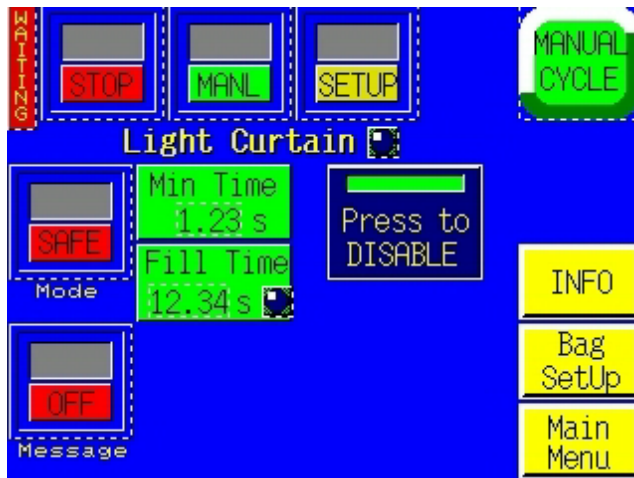

Fig. 3-15

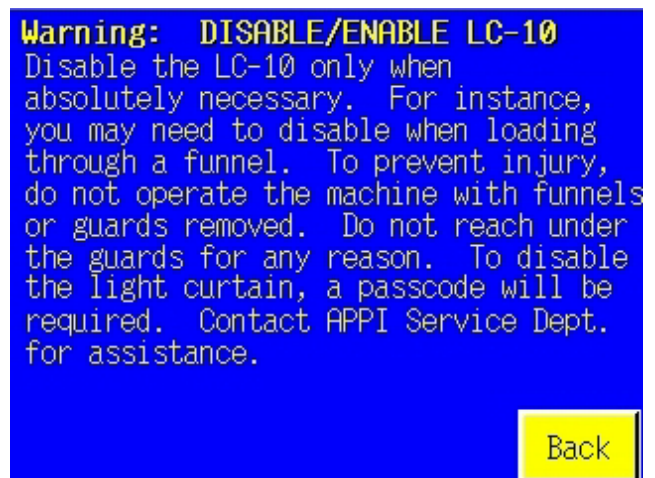

Fig. 3-16

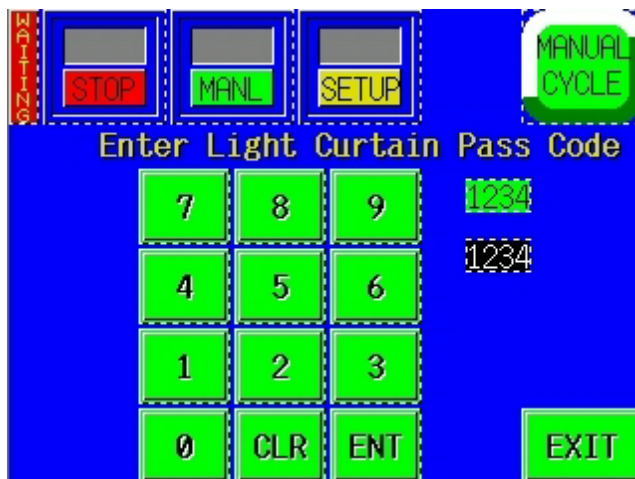

Fig. 3-17



Fig. 3-18

Caution: To avoid personal injury, do not attempt to disable the Light Curtain option unless a funnel is added which physically blocks the path to the heater bar.

If you need to add a funnel or chute which causes the light curtain area to be permanently blocked, and this funnel or chute also prevents the operator from reaching into the seal area, the light curtain can be deactivated. See Fig. 3-16.

To deactivate the light curtain, press the button labeled <Press to Deactivate>. A keypad will be displayed which will require a special code. Unless you know this code, you cannot deactivate the light curtain option. Contact APPI Service Dept. for the pass code to disable the option. See Fig. 3-17.

If the light curtain is blocked for several seconds, a message will be displayed preventing the machine operation. You must then either unblock the light curtain area or deactivate the light curtain. See Fig. 3-18.

3.24 Estop Option

The Estop option is not included in the standard T-1000 package and must be purchased separately. This option can be used to stop the cycle operation of the T-1000 and possibly other auxiliary infeed or outfeed equipment if purchased with the T-1000. This option is useful if a full system is purchased which may run in an automatic operation. One or more Estop buttons may be incorporated to stop one or more operations. See Fig. 3-19.

If depressed, the Estop button will cut power to the drive motors, turn off air pressure or otherwise halt moving components within the system. However, due to the wide range of equipment options, E-stops may function differently from one system to another depending on the components and safety requirements requested. When the Estop is pressed, a message screen will be displayed. See Fig. 3-20.

3.25 Ti-1000 Inline Printer

A Printer option not included in the standard T-1000 package and must be purchased separately. Used for product identification, it will print information, graphic images or bar codes directly to the surface of the film using a ribbon foil to transfer ink. See Fig. 3-21.

The Thermal Inline Transfer Printer - prints text, graphics and bar codes, formatted in a separate software program. The label formats, saved in a P.C. structure can be recalled and "downloaded" to the printer.

To enable Printer operation on the Thermal Transfer (TT) Printer, press the highlighted <Printer Ti-1000> button. Toggle switch to <ON> or <OFF> to disable the operation of the printer. See Fig. 3-22.

3.26 CF-10 Counting Funnel

A Photo optic and preset Counting option not included in the standard T-1000 package and must be purchased separately. This option is useful to automatically cycle the bagger when a preset number of parts have fallen through the funnel. See Fig. 3-23.

Photo optic eyes may vary depending on your product, so parts should be sent to APPI for testing to determine the correct components. Parts must be separated to be counted accurately through the eye. If two parts fall at the same time, they may be counted as one. If loading automatically with minimal distance between parts, an accumulating funnel or method of diverting may be required for separation between the last part in the batch count and first part in the next batch. Contact APPI Sales Support for additional options, programming or operations for automatic infeed operations.



Fig. 3-19



Fig. 3-20

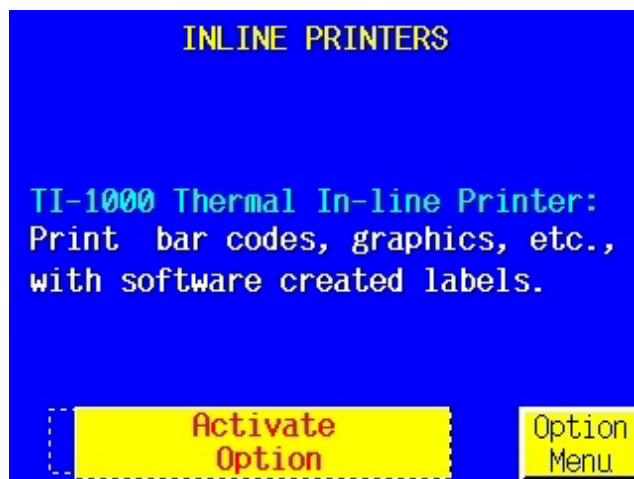

Fig. 3-21

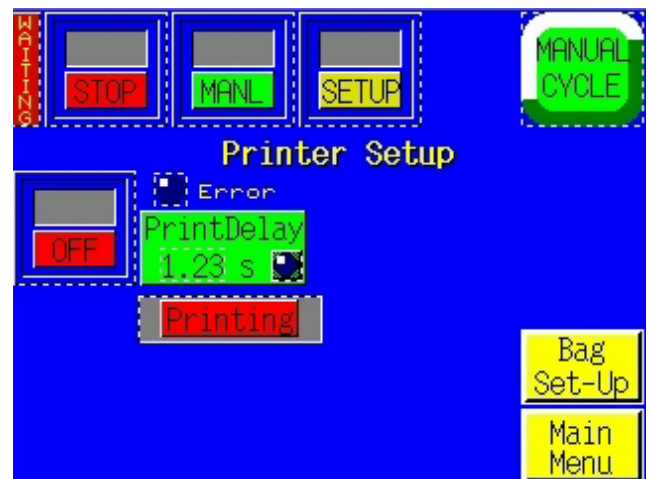

Fig. 3-22

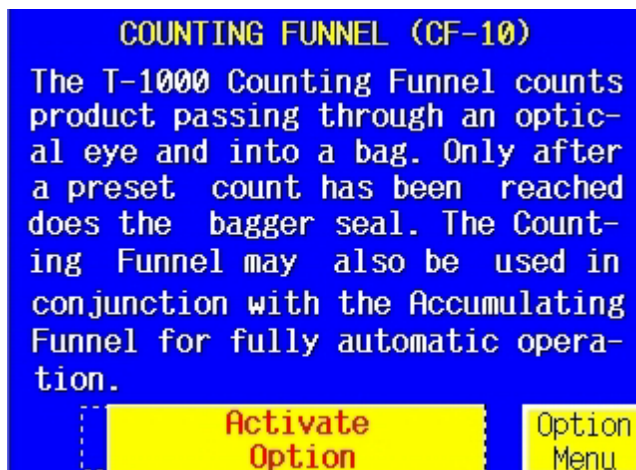

Fig. 3-23

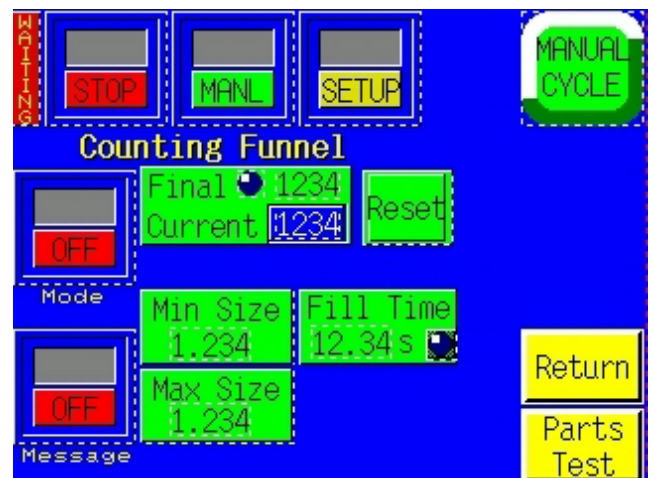

Fig. 3-24

To turn ON the option, press the Mode toggle button. See Fig. 3-24. Press the <Reset> button to reset the count to the preset value.

Parts length test: With the option ON, go to the Parts Length Test Screen, press the <Reset> button. Toggle the T-1000 to the Stop mode using the Toggle button located at the top left side of the screen. Then, drop parts individually through the photo sensor / funnel. You will notice that the Min and Max values will change as you drop parts through the eye. If the parts will be fed automatically, parts should pass through the eye as they would if feeding automatically. See Fig. 3-25.

Min Setting: The Minimum Setting is used to filter scrap. If through testing the min value detected was .2, setting the value to .1 would cause parts that are .1 or less not to be counted. If you set the Min. Setting too close to the actual minimum test value however, these parts may not be counted causing over counts. Setting the Minimum Setting to Zero will cause all parts to be counted.

Maximum Setting: The Max Setting is used to count parts connected or parts falling through the eye together (overlapped) as two parts. If when testing the parts length, the Max value was determined to be .5, you could set the Max Setting to .8. Then, if two parts overlapped go through the eye with a setting a .9, they would be counted as two parts. However, if you set the Max Setting too close to the Max Value, one part may be counted as two, causing undercounts. To disable this 2 count function, set the value to zero.

A help screen is provided to further explain Min and Max Settings. See Fig. 3-26.

When the final count has been reached, a message can be displayed by toggling the Message button to ON. The message will display the final count and tell the operator to stop loading until the bag is ready to receive the next batch. See Fig. 3-27.

If the eye is blocked for an extended period of time (parts jam), the machine will stop and a message will be displayed.

3.27 AF-10 Accumulating Funnel

A Photo optic and preset Counting option not included in the standard T-1000 package and must be purchased separately. This special purpose funnel has several functions: 1) to collect (accumulate) a product before dropping the full contents of the Accumulator into the bag, 2) to contain a product while the bagger is in a CYCLE operation (sealing, tearing off, and indexing a bag into position), 3) to insert the funnel into the bag and keep the product away from the sealing portion of the bag (Insert Funnel) and 4) to physically open the bag with a gate that enter into the bag while the product exits the funnel. See Fig. 3-28.

Increased production can be achieved in manual load or automatic load operations. In a manual operation, the operator can insert the product into the funnel without waiting for the bag to be in position and opened. When the bagger is ready to receive the product, the door at the bottom of the funnel will open, drop the product and shut, to allow the funnel to again be loaded.

In an automatic operation, increased production can be achieved by allowing counters, fillers, scales and other infeed equipment to feed the funnel without regard for the status of the bagger.

Additionally, the funnel can be operated in an "Open Accumulator" mode or a "Closed Accumulator" mode. In an Open Accumulator mode, the door is closed only during the CYCLE operation. When the door opens (when the bag is in position and blown open), the door will open and remain open until the bag has been filled with the required amount of product. The door will then close only until the next bag is in the Closed Accumulator mode, the door remains closed until the full contents have been inserted into the funnel. When the bag contents is reached in the funnel, the door will open and all of the product will enter the bag in one.

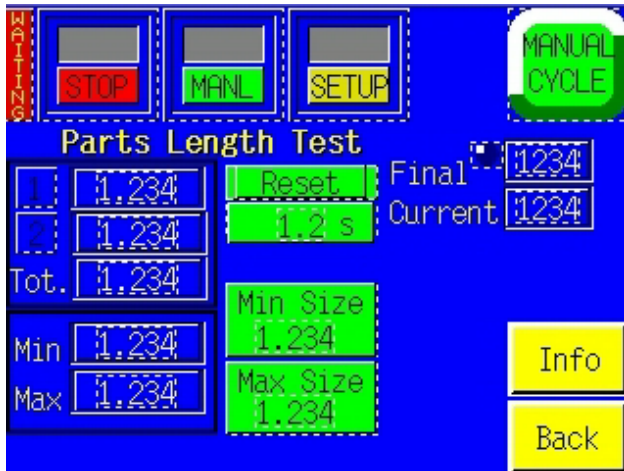

Fig. 3-25

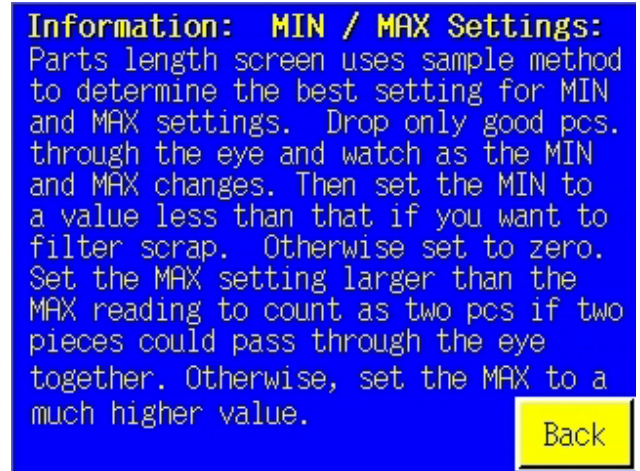

Fig. 3-26



Fig. 3-27

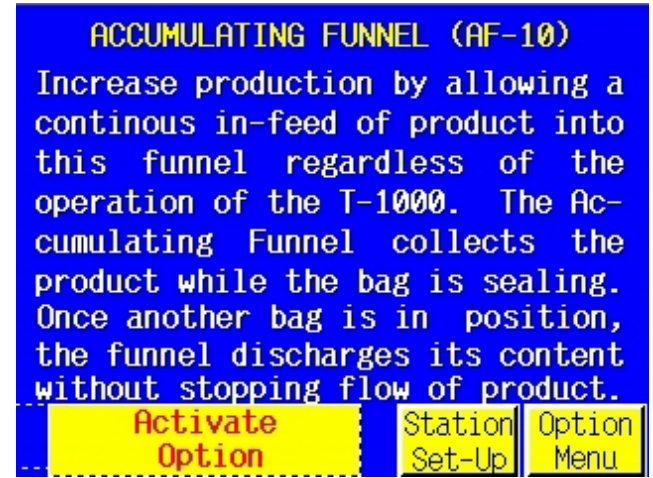

Fig. 3-28

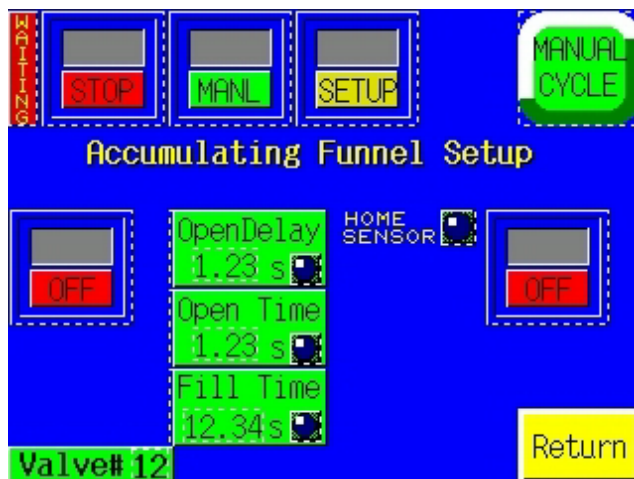

Fig. 3-29



Fig. 3-30

To turn ON the option press the Mode Toggle button. See Fig. 3-29.

The Setup screen displays the time, in seconds, which the bagger will wait after the door opens (product drops). Depending on whether you are in the Open or Closed mode, adjusting the <Door Delay 1> or <Door Delay 2> settings will cause delay in the opening or closing of the funnel.

Note: Valve #X indicates the Valve Station number assigned to this option. Valve #0 indicates that no valve is assigned to this option. The option will not operate unless a Valve Station number is assigned, other than 0.

3.28 BO-20 Bag Open Detector

A Photo optic or Closed Contact sensor to detect the opening or presence of bag material is available for purchase, not included in the standard T-1000 package. See Fig. 3-31.

This option will detect whether or not a bag is blown open, or whether or not a funnel is inserted into the bag for validation that that bag is ready to receive product. This option is valuable for an automatic operation to decrease the chance of product falling on the floor. See Fig 3-32

3.29 Bag “Out” Sensor

A Photo optic or Closed Contact sensor to detect the presence of bag material is available for purchase, not included in the standard T-1000 package. If the bag material ends, a message will be displayed indicating out of bags or a threading or web breakage issue.

3.30 DF-20 Part Diverter (Diverting Funnel)

A Photo optic and preset Counting and Diverting option is not included in the standard T-1000 package and must be purchased separately. See Fig. 3-33.

This feature is used to count bags from the bagger and divert them for further packaging operations including counting into cartons. See Fig. 3-34.

Note: Valve #X indicates the Valve Station number assigned to this option. Valve #0 indicates that no valve is assigned to this option. The option will not operate unless a Valve Station number is assigned, other than 0.

3.31 CS-10 Compartment Seal

Special programming is required to seal the bag twice with compartments within the same bag. This option is not included in the standard T-1000 package and must be purchased separately. For instance, it may be necessary to segregate a sharper object (screw) from a plastic component (mounting plate) to avoid the screw damaging the plastic part. See Fig. 3-35.

Both seal points can be adjusted by the operator to increase or decrease the size of each compartment. However, the larger object should be placed into the bag first.

First set Seal Point 1 by pressing the <Seal Point 1> button and typing in the value on the number keypad. Adjust the first seal point until the desired location is achieved. Then, turn the option ON by toggling ON the ON/OFF button. Adjust the second seal point by pressing <Seal Point 2> and entering a value in the number keypad. Adjust the value of the second seal point until the desired position is achieved. Each seal time may be adjusted if you wish the Trim Seal after the second seal has been placed on the bag. See Fig. 3-36

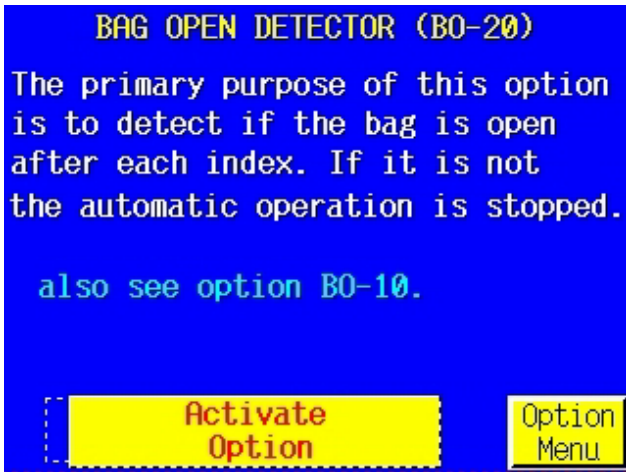

Fig. 3-31

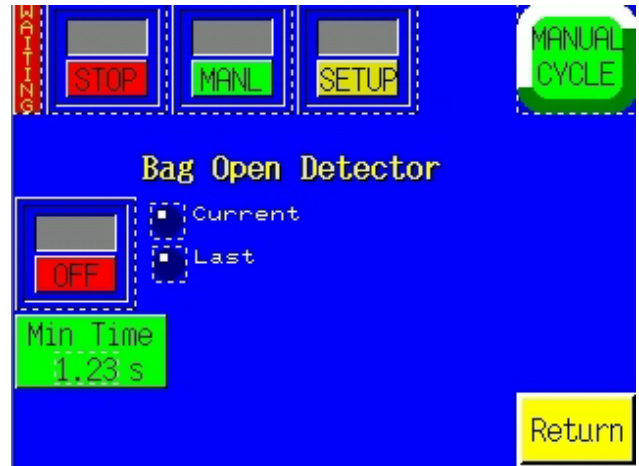

Fig. 3-32

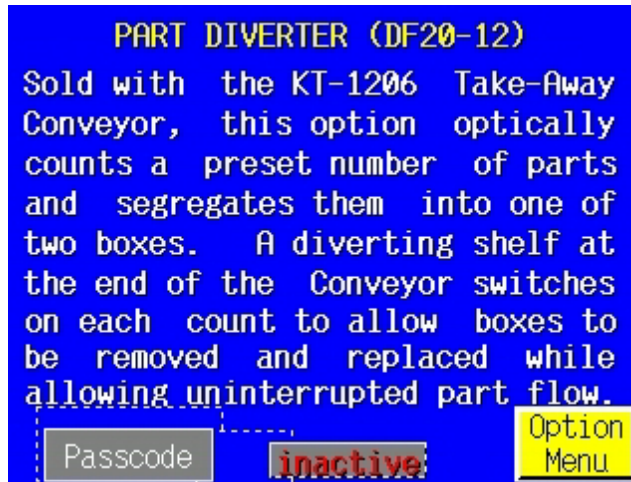

Fig. 3-33

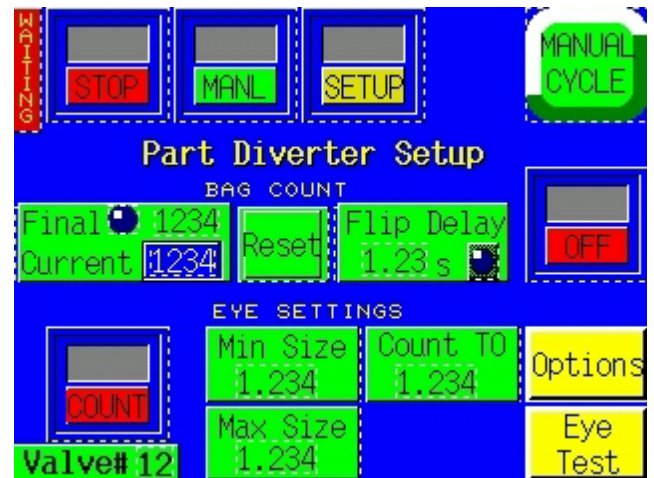

Fig. 3-34



Fig. 3-35

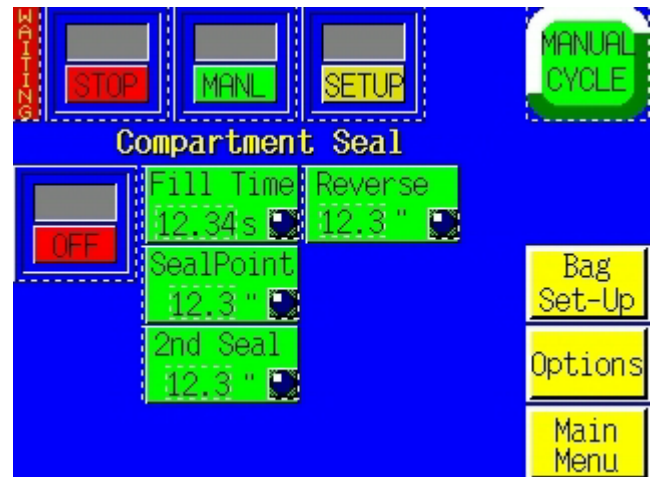

Fig. 3-36

3.32 TS-10 Twin Seal Feature

Special programming is available to seal the bag twice. This option is not included in the standard T-1000 package and must be purchased separately. An additional seal can be placed on the bag based to increase the integrity of the bag. See Fig. 3-37

To turn on the Twin Seal™ option, press the <Twin Seal> menu option and toggle the option ON. Adjust the second seal point.

Note: You may need to decrease the Seal Point value on the Bag Setup Screen to allow space for two seals on the same bag.

Note: Weight of the product, special load shelves or other options, funneling and bag size will affect the operation of this option. Contact APPI Sales Support for more information.

3.33 MV-10 Seal Validation

The Seal Validation option is not included in the standard T-1000 package and must be purchased separately. APPI provided additional components to provide a secondary means detecting a failure or out of range condition for components that affect seal quality. See Fig. 3-38 and 3-39.

To cause a good seal and to confirm that each component required to obtain the seal is in range, we have added three validations to the T-1000:

1. Seal time: sensors were added to the seal bar to measure how long the seal bar is engaged to validate that the heater bar is extended within an acceptable time compared to the set seal time.
2. Pressure: a pressure sensor was added with an alarm output that alarms when the pressure falls out of the set range in the pressure sensor.
3. Temperature: a secondary controller was added with an alarm output that alarms when the temperature falls out of the set range in the temperature controller.

Typically, medical companies require seal validation as a secondary means to detect out of range conditions are to stop the operation when the condition exists. A Message will be displayed if any of the three validation components are out of range. See Figures 3-40, 3-41 and 3-42.

The Pressure Sensor may be also be added to the T-1000 to validate only pressure, without adding the other two components. For application requiring this validation only, the bagger will not operate unless the sensor provides an output indicated that the pressure is above a minimum allowable setting.

3.34 BV-10 Barcode Reader Option

As an optional device, a barcode reader can be purchased from APPI to verify that a barcode is readable. If no barcode is detected, or if a barcode is not correctly formatted (as per software settings in the barcode verifier), then a NO READ message will be displayed. See Fig. 3-45.

To turn on the option, press the ON toggle button. Press the TEST button to send a sync signal to the barcode verifier to turn on the scanner. In this mode, the verifier can be used to scan individual barcodes. See Fig. 3-43.

Option 1 or Option 2 mode can be used depending upon the sequence of operation desired. Press the Help menu button for a description of the mode of operation for Option 1 and Option 2.

For each barcode successfully read, the status box will provide a GOOD message. If a NO READ occurs, a message will be displayed.

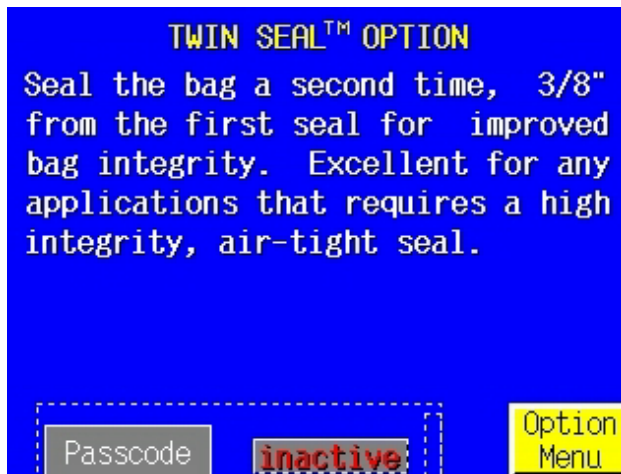

Fig. 3-37



Fig. 3-38

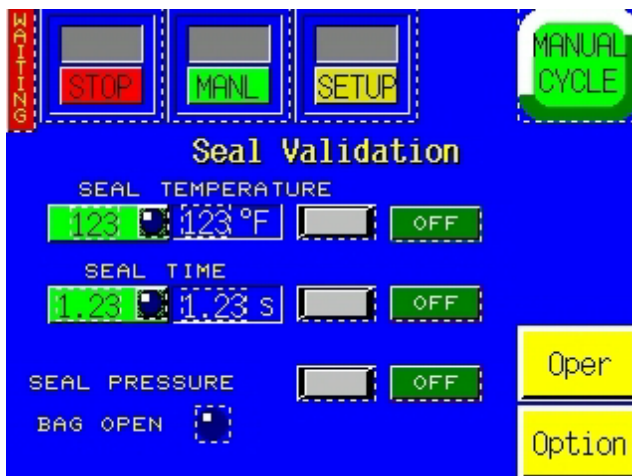

Fig. 3-39



Fig. 3-40



Fig. 3-41



Fig. 3-42

3.35 IF-10 Insert Funnel

A special funnel is offered to enter the bag so that the product does not contaminate the seal area, or the air can be shutoff or to facilitate proper loading. This special purpose funnel is not included in the standard T-1000 package and must be purchased separately. See Fig. 3-47.

The funnel enters the bag and remains in the bag until signaled with a foot switch or automatically by a filler. To turn the Insert Funnel ON, press the toggle button. To disable the air, press the Air Delay, type in the amount of time the funnel is filling up the bag before the air should shut off. See Fig. 3-48.

Note: A sensor input is required to confirm that the funnel is in the bag, prior to providing an auxiliary output. If the sensor does not detect the presence of the bag around the funnel, no signal output will be provided and the system will be halted.

Note: Valve # X indicates the Valve Station number assigned to this option. Valve #0 indicates that no valve is assigned to this option. The option will not operate unless a Valve Station number is assigned, other than 0.

3.36 BO-30 Bag Opening Device

A special device to assist in opening and maintaining a bag opening is offered by APPI. This device enters the bag with one or more “fingers” and then pulls the bag open to a stop. The stop holds the bag open during loading and also validates that there is bag material present in the “gripper”. Air can also be shut off at this point. This special purpose device is not included in the standard T-1000 package and must be purchased separately. See Fig. 3-49.

To turn ON this option, press the Toggle button.

<Reject Count> is typically set to 1 which, after one unsuccessful attempt to open and hold open the bag, a message will be displayed and the operation halted. See Fig. 3-50. If set to 2, for instance, the fingers will try one more time to enter the bag and pull it open to the gripper.

<Fill Time> is the amount of time, in seconds, that an output will be sent to an auxiliary piece of equipment, after the bag has been opened and the opening validated. A typical value is .2 seconds.

<Down Time> is a delay time before the finger will attempt to enter the bag, after it is initially blown open. A typical value is .5 seconds.

<Close Time> is the amount of time, in seconds, after the fingers have entered the bag, before the fingers will pull the bag to the gripper point. A typical value is .4 seconds.

<Open> Cycle button allows you to test cycle the Bag Opening Device alone, without initiating other equipment or the T-1000 seal operation.

A Help Screen for the Bag Opener Operation is provided for information.

Note: Valve # X indicates the Valve Station number assigned to this option. Valve #0 indicates that no valve is assigned to this option. The option will not operate unless a Valve Station number is assigned, other than 0.

3.37 ST-10 Stack Light Option

The ST-10 Stack Light option is not included in the standard T-1000 package and must be purchased separately. This option consists of a two or three LED options. Two LED indicates on Operation Condition (Green) or a Stop/Fault Condition (Red). Three LED indicates the same as the two LED

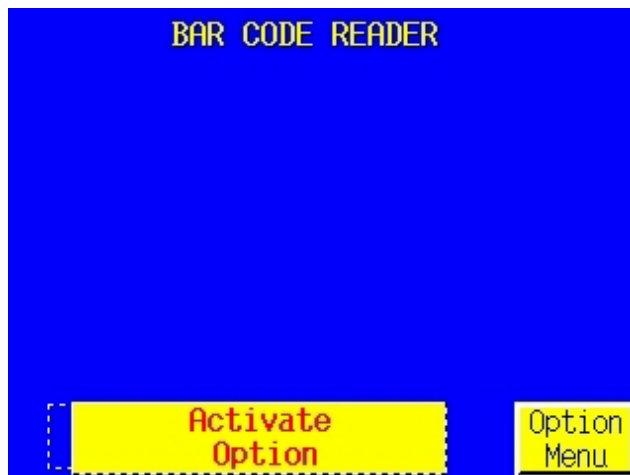

Fig. 3-43

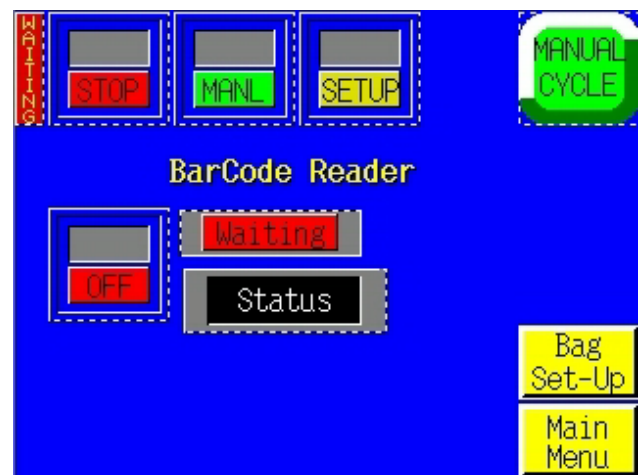

Fig. 3-44



Fig. 3-45

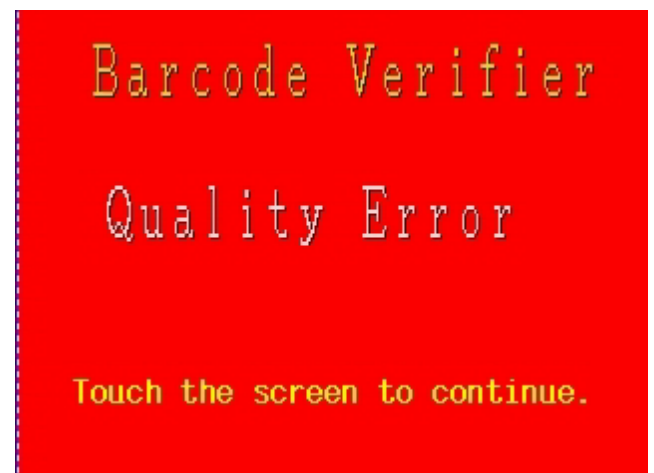

Fig. 3-46

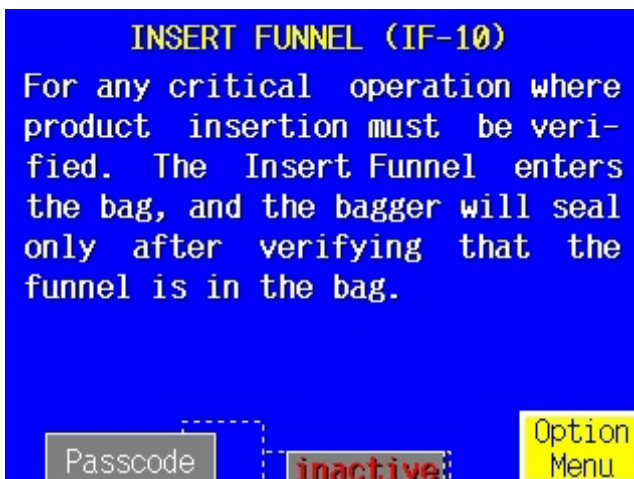

Fig. 3-47

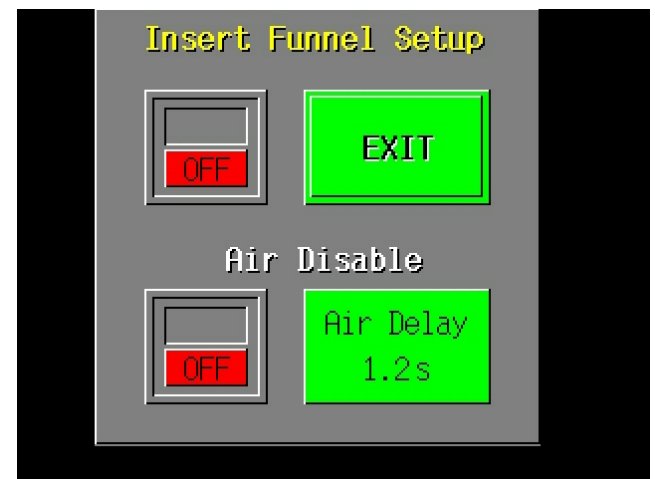

Fig. 3-48

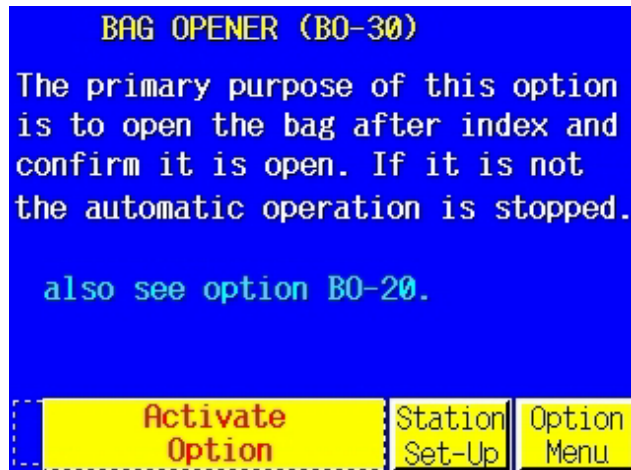

Fig. 3-49

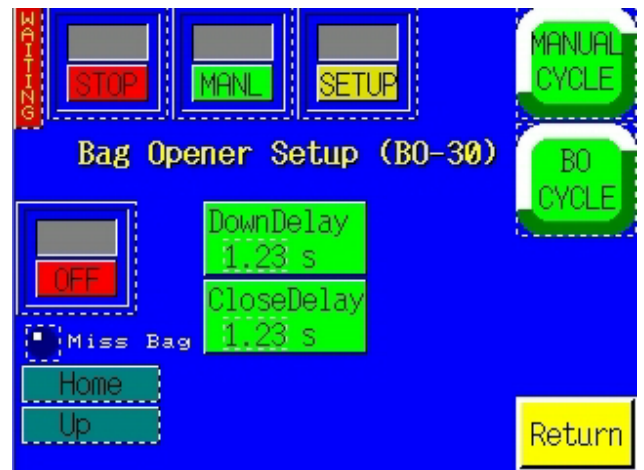

Fig. 3-50



Fig. 3-51

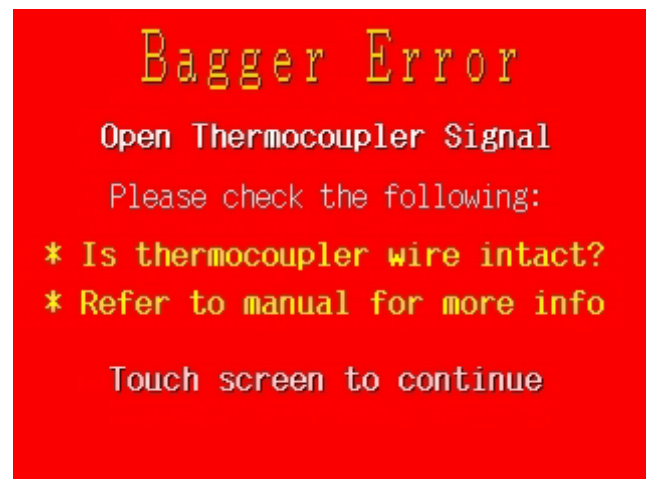

Fig. 3-52



Fig. 3-53

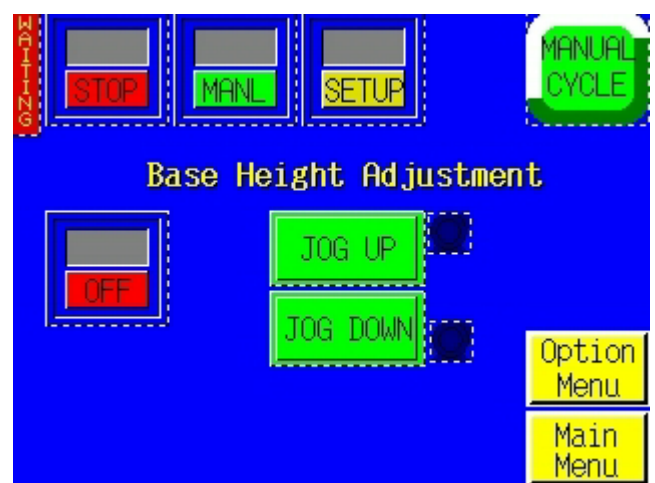

Fig. 3-54

option, but adds a Warning condition (Yellow) which can be used for low materials or other warnings within a system.

3.38 Base Height Adjustment

An option that allows the T-1000 Bagger to be conveniently versatile is the “Base Height Adjustment” Option, which allows the operator to raise or lower the base of the bagger, which is necessary particularly when other equipment, such as conveyors is to “work” with the Ti-1000. See Fig. 3-53 To adjust the base of the bagger, select the “Height Adjustment” button from the Option Menu and turn it “ON”. To raise the bagger select “JOG UP”, to lower the bagger select “JOG DOWN”. See Fig. 3-54

3.39 UF-5000 Infeed Conveyor Operation Screen

The T-1000 is programmed to also control the UF-5000 Infeed Conveyor. This screen allows the operator to setup the conveyor to run standalone, with the T-1000 or with parts counters. See Fig. 3-55.

CONV CYCLE button manually cycles the conveyor and also toggles OFF auxiliary mode buttons and bagger Run buttons.

SETUP/RUN button toggles ON the conveyor to operate with the T-1000.

ON/OFF Bagger Auxiliary button sets up the communication with T-1000.

ON/OFF Counter Auxiliary button sets up the communication with counters (UC-2400).

PART SENSOR turns on photo eyes mounted in the discharge funnel of the UF-5000 (CE-10) option, if equipped.

Index Count value is the number of compartments that will be indexed before providing an output signal to the bagger.

The UF-5000 is equipped with an emergency stop (ESTOP) switch, either a push button or pull cord. When the button is pressed, a screen will appear indicating this condition.

3.40 UF-5000 Infeed Conveyor Settings Screen

The UF-5000 settings screen provides all the settings to control production speeds and timing of the integration components of a system. See Fig. 3-56.

Fill Time is the amount of time from the time the conveyor cycles to the point that the bagger cycles.

Flight Delay is the delay time that the flight sensor is active when the flight (cleat) passes through the optical eye (normally set a .2 sec.). Light/Dark setting is determined by the type of sensor used to detect the cleats (typically set at Light).

Input Delay is the amount of time from the point the conveyor receives a signal to index before the conveyor indexes.

Output Delay is the amount of time after the conveyor indexes before the conveyor signals the bagger that it has cycled.

Sensor Delay is the amount of time after the conveyor indexes that the photo eyes (CE-10 option) “looks” for a parts before indexing another compartment of the conveyor.

Funnel Delay is the amount of time after the conveyor indexes to the point that an accumulating funnel (AF-10 option) cycles (if equipped).

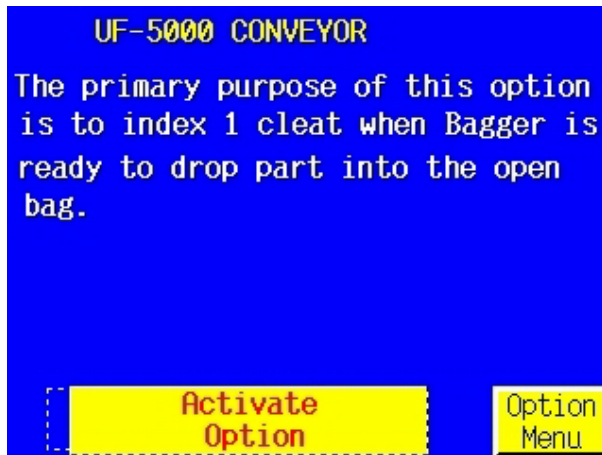

Fig. 3-55

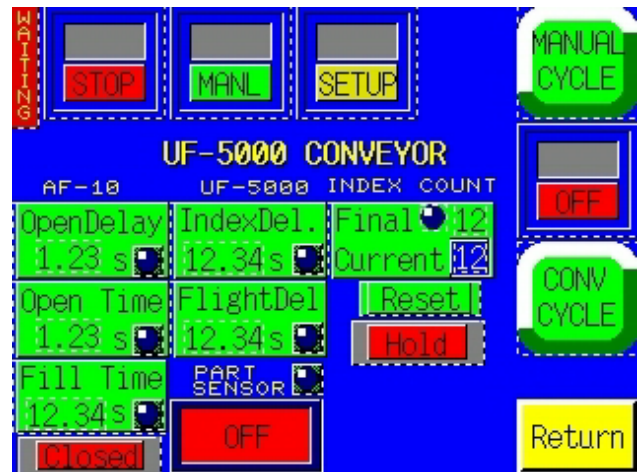

Fig. 3-56



Fig. 3-57



Fig. 3-58

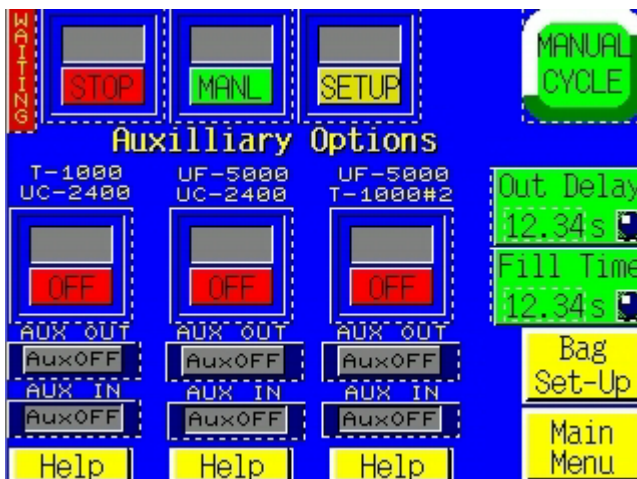

Fig. 3-59

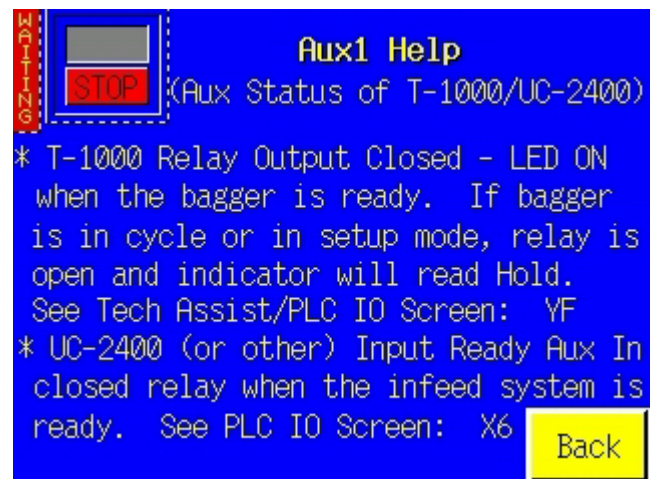

Fig. 3-60

Adjust each timer by pressing the associated timer and entering the value on the number keypad. After each value, test the settings by cycling the conveyor. Press the UF-5000 Mode button to return to the UF-5000 Operation Screen.

3.41 US-5000 Semiautomatic Net Weigh Scale Operation Screen

The US-5000 “Kit” Net Weigh system is a versatile semiautomatic bagging system which provides For fast bagging of kits or one type of part per bag, in counts up to 10,000 pieces.

If your company bags a wide variety of parts with multiple parts of various counts in bags, the US-5000 Kit Packaging system is an excellent solution.

This option is accessed through the Ti-1000 screen. A separate manual is provided if this option is purchased or is available upon request

3.42 Auxiliary Screen

The T-1000 Touch Screen Program is preprogrammed to accept most infeed equipment signals so that the two or more pieces of equipment "talk" to each. Occasionally, reprogramming will be necessary to interface auxiliary (infeed) equipment that is not manufacturer by APPI. Additional cabling may will be required which will transfer the signals between the T-1000 and your existing equipment.

Once connected and with both systems running independently, turn the Auxiliary Signal ON by pressing the ON/OFF toggle button from the Auxiliary Screen. An output time delay is provided which delays the bagger from sealing after the auxiliary infeed signal has cycled and signaled the bagger to seal. To adjust the delay timer, press the <Output Delay> button and enter the value, in seconds, on the number keypad. See Fig. 3-59

Help screens are available See Figures 3-60 thru 3-62.

CAUTION: We recommend that APPI technicians provide the cable(s) linking the equipment. Contact APPI customer support for information which will be required for the integration.

When the Auxiliary setup procedures are complete, toggle the T-1000 from <Manual> to <AUTO> by pressing the <Manual/Auto> toggle button. This will place the T-1000 in the Automatic / Auxiliary mode.

3.43 Job Save / Recall

The T-1000 is able to store 32 machine settings, called *jobs*, including BAG SETTINGS and OPTIONS SETTINGS. See Fig. 3-63.

Each time a setting is changed on the T-1000, the settings are immediately saved in memory so that if power is lost, the T-1000 will power on with the job that was running before power was lost.

To Save a job, press the <Job Save> from the Main Menu. To recall a job already saved press the desired job slot. On the numerical keypad screen press <View> to check settings, see fig. 3-64,

To save a new job, press <Job Save> from the Main Menu, then select an empty Slot. From the numerical keypad, assign a number for the new job. Once entered press the <Save> button to save settings.

If you attempt to load a job that does not exist, a message will be displayed.

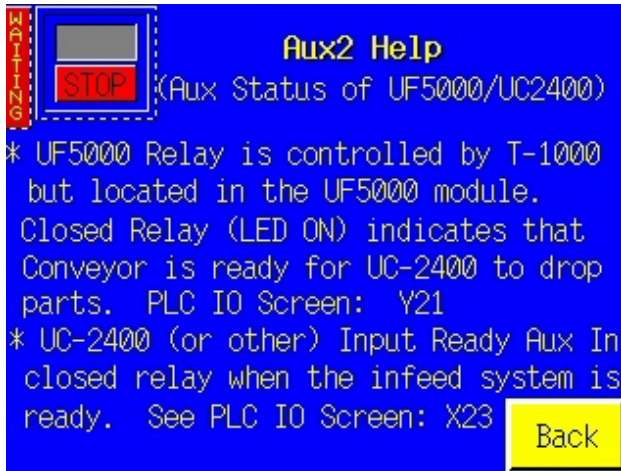

Fig. 3-61



Fig. 3-62



Fig. 3-63

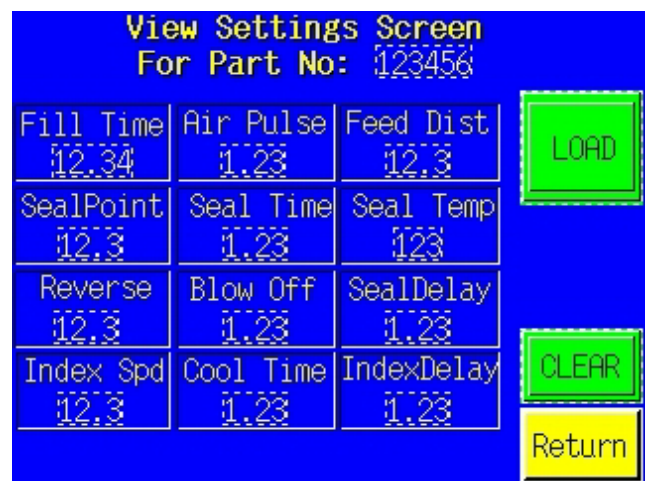

Fig. 3-64

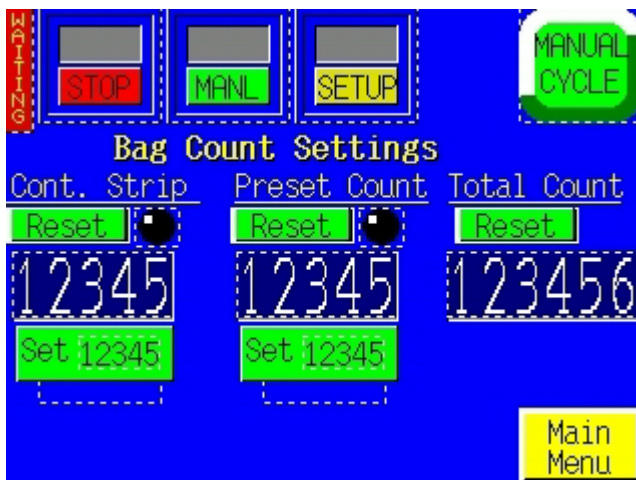

Fig. 3-65



Fig. 3-66

3.44 Counters Screen

The T-1000 is equipped with three internal counters as a standard feature. To access the counter screen press the <Counter> button from the Main Menu. See Fig. 3-65.

Continuous Strip Counter: This option allows you to seal bags in a strip, without separating them at the perforation. If you set this counter value to 10, for instance, you will have a strip of 10 bags connected. The bagger will then reverse to separate the 11th bag.

Press the <Reset> button to reset the counter to the set value. To disable the option, set the value to zero.

Note: If you don't want the bags separated ever, you can either set the counter value to very large number or simply change the Reverse setting to zero in the Bag Setup Menu.

Totalizing Counter: To track production, use the Totalizing Counter to count cycle operations of the T-1000. Press the <Reset> button to reset the counter to zero. This counter value is also displayed on the Operation Screen.

Predetermining Counter: To halt production after a preset number of cycle operations, use the Predetermining Counter. When the final count has been reached, a message screen will be displayed. See Fig. 3-58.

Set the value by pressing the <Set> button and then type the value on the number keypad followed by the <Enter> button. To disable the Predetermining Counter set the value to "0".

3.45 Production Chart

APPI provides a simple graph to chart production throughout the day. See Fig. 3-66.

Press the < (left arrow key) to scroll back, 1 hour at a time, to review past production. Press the > (right arrow key) to check more recent production information. Press the <CURNT> Current button to display the current hourly production information.

Press the <Reset> button once to reset the production time and twice to reset the graph.

3.46 Temperature Graph

APPI provides a temperature graph to display the operating temperature during production. This information is useful if bags are found to have weak seals, in isolating the problem by reviewing previous operating temperatures. See Fig. 3-67 and 3-68.

The << (left arrow key) is used to view prior operating temperatures and the >> (right arrow key) is used to view more recent temperatures. Pressing the <Curnt> Current button will display the current hour of operating temperatures. Press the <Reset> button to reset the graph information.

3.47 Technical Assistance

The Technical Assistance screen provides manufacturer information, factory settings adjustments and functions testing and troubleshooting. It also displays program version for PLC controller and touch screen. See Fig. 3-69.

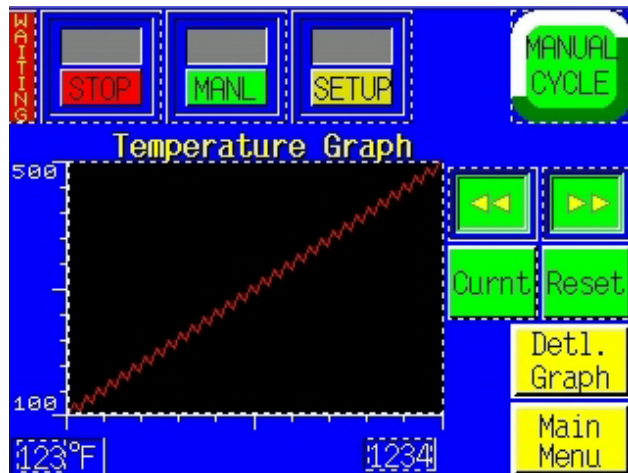

Fig. 3-67

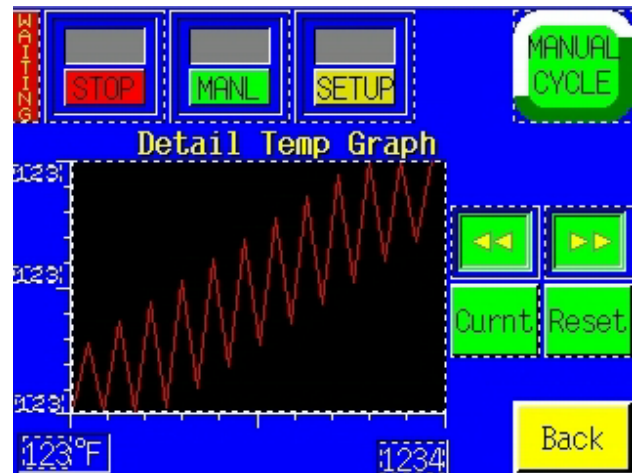

Fig. 3-68



Fig. 3-69

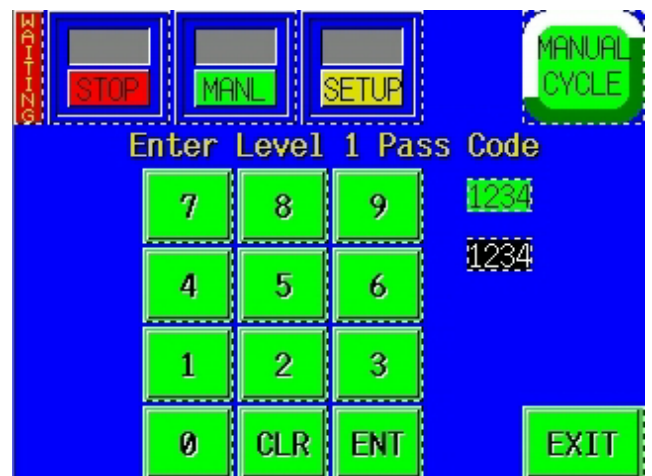

Fig. 3-70

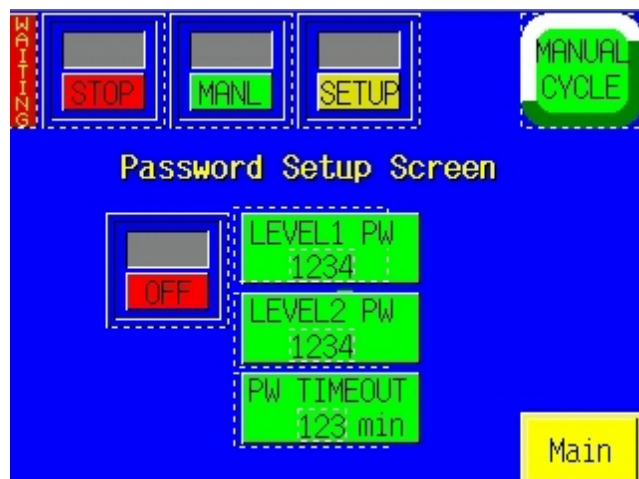

Fig. 3-71

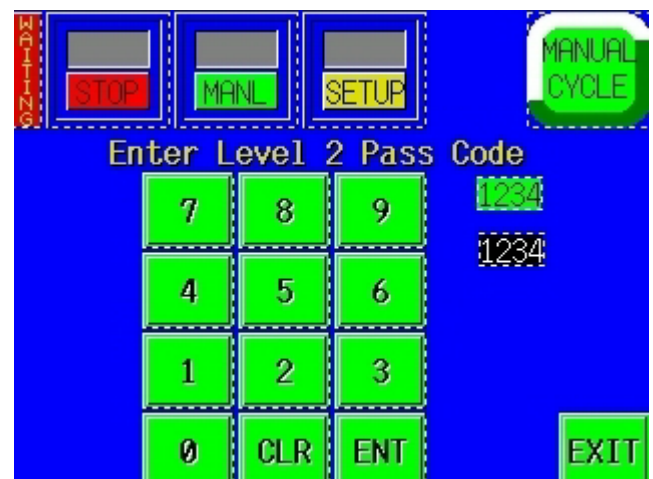

Fig. 3-72

The screen is protected from access with a Level 1 pass code. The pass code is set by default (from the factory) to 1001. See Fig. 3-70. This code can and should be changed when the system is put into operation.

Several menu options are available from the Tech Assist. menu which will assist with troubleshooting the T-1000 and also change settings that affect the operation of the equipment.

3.48 Pass Code Setup Screen

Advanced Poly-Packaging, Inc. (APPI) has included a pass code function in all touch screen equipment to prevent operators from changing settings. See Fig. 3-71.

There are two pass code levels described as follows:

1. Level 1: This is the highest level pass code which prevents operators from accessing the Technical Assistance functions of the machine. The default pass code, when shipped from the factory, is 1001.
2. Level 2: This level pass code, when the pass code function is enabled, prevents the operator from accessing settings screens that affect the operation of the equipment. See Fig. 3-72.

Pass codes prevent unauthorized individuals from tampering with settings. When equipment is shipped, APPI uses the following codes which should be changed prior to putting the T-1000 into operation.

Factory Set Pass Codes:

1. Level 1 pass code: 1001
2. Level 2 pass code: 1002

To enable the pass code function, press the <Tech Assist> button from the Main Menu. Type in the Level 1 pass code (1001 by default from APPI). Press <Bagger PassC> Then press ON to toggle the pass code function ON. If you change the pass codes, ensure that these codes are written down.

Once the pass code function is enabled, the operator will have a programmed amount of time (time-out time) to make changes. Once this time has elapsed, the Operation Screen will automatically be displayed. This time can be changed by accessing the Bagger PassC setup screen.

If you misplace or forget the pass codes, contact APPI Service Dept for assistance. APPI will provide a “factory code” so that the current pass codes can be displayed. Once you receive the factory code, press F5 function key, located to the right of the touch screen, to enter the factory code and your current pass codes will be displayed.

3.49 Options Enable Pass Codes

The Options Enable Screen is used at the factory to “enable” options for use by the operator. A status box is located to the left of the option to indicate if the option is available to operator. If OFF, the option settings screen will not be displayed for use by the operator. See Fig. 3-73 and 3-74.

Options must be purchased from Advanced Poly-Packaging, Inc. to obtain the password. Contact Advanced Poly-Packaging, Inc. Service Dept. for more information regarding options available for the T-1000.

3.50 Valve Station Setup

The T-1000 is equipped with a valve station that is wired from DB25 connector/open ended cable to the PLC. Each wire is pre assigned to a PLC output, but options that are available are not assigned to a solenoid valve until the machine is ready to ship from the factory.

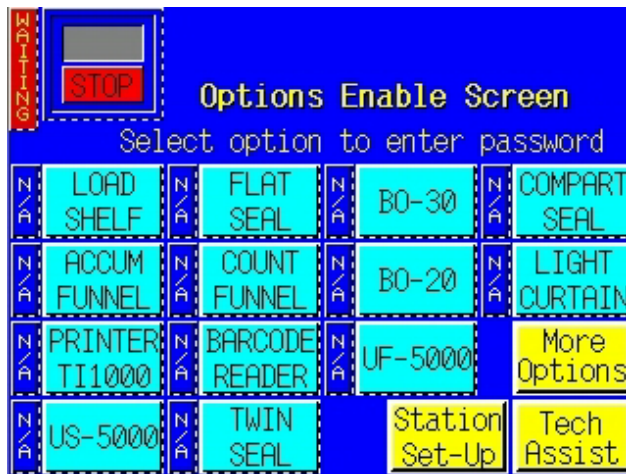

Fig. 3-73

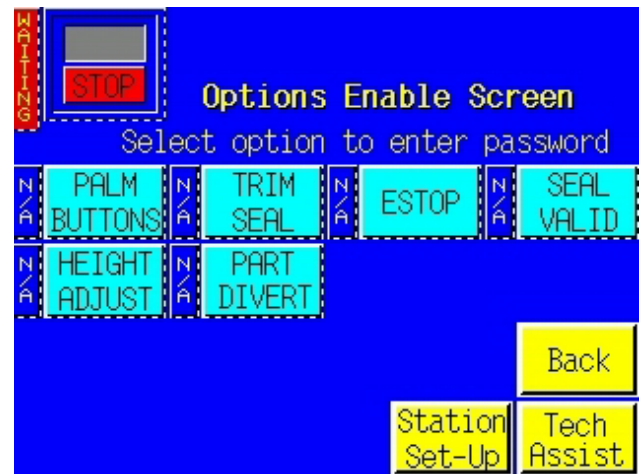

Fig. 3-74

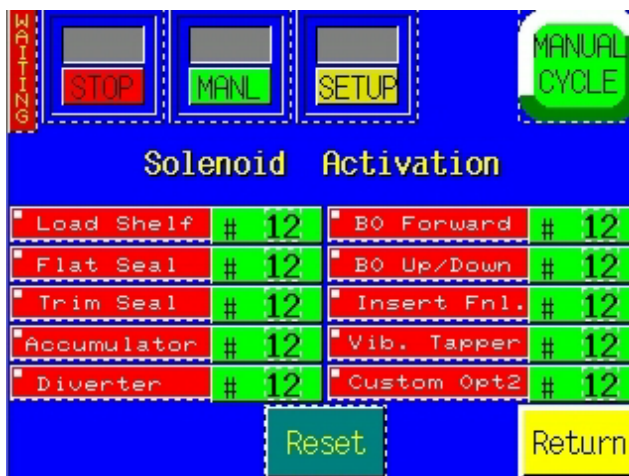

Fig. 3-75



Fig. 3-76



Fig. 3-77

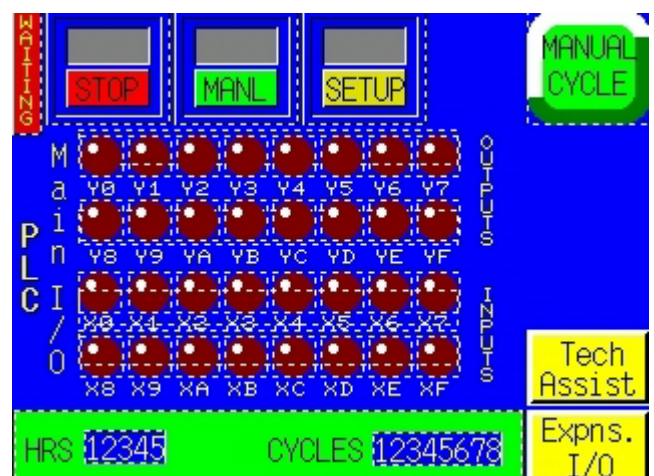

Fig. 3-78

Each valve is assigned a “station” number. Stations 1 through 4 are fixed and programmed to operate a standard T-1000 in a fixed sequence of operation. However, when options are added, the sequence of operation changes. Additionally, outputs from the PLC to the valve are assigned, depending on the options equipped.

For instance, if a LS-10 Load Shelf option is added and the valve station assigned is #6, the T-1000 Valve Setup Screen must be accessed and the Load Shelf option assigned to Station #6. See Fig. 3-75.

To assign an option to a Valve Station, press the option and on the number keypad, press the number followed by the <Enter> button.

Note: You will not be able to assign two options to the same Station number. A message screen will be displayed if you attempt to assign two options to the same Valve Station number. The message will also be displayed if you attempt to leave the Valve Station setup screen with two options assigned to the same valve.

To start over, press the <Reset> button. Contact APPI Technical Support for assistance.

3.51 Factory Settings

These settings are additional bagger settings which should only be set by qualified technicians or by the factory. See Fig. 3-76.

Heat Off - The amount of time that will pass before the heater bar will turn off automatically, while the machine is still “ON” during for example operator breaks.

Temp Range - The range above and below the temperature set point where the bagger will display “Ready” and allow normal operation. If the temperature is out of this ranging a Warning signal will display

Feed Dist- displays a distance in inches where perforation sensor is not looking for a perforation. Example : if there are other holes in the bag. *Note: Normal distance is 0”-2”*

Seal Delay - amount of time the seal is delayed after the air is turned off, so that the air can escape the bag.

Cool Time - after the pressure bar and the heater bar come into contact, the amount of time the pressure bar is released to ensure the seal is cool enough to be torn off.

Index Delay - after the bag is released the next bag is fed into place, the delay allows the previous bag time to get out of the way so that the bag doesn’t beat the seal bar coming into contact and causing a bag “jam”.

Note: It normally takes 3-4 minutes to bring the heater bar to temperature depending on the Seal Temp. value and the current temperature of the heater bar.

Job Default - If pressed, all settings will revert back to the factory settings. These settings may be used to simplify the troubleshooting procedures by APPI Service Personnel.

Zero Perf Setup Routine - This feature is used to initially setup the bagger to register a zero seal point. In other words, if the bagger could be set to a Seal Point of 0.00, the perforation would be

located at the seal point. This then becomes the reference point when adjusting for the Seal location. It also prevents the operator from entering a seal point which would miss the bag.

Step 1: Press the <Zero Perf> button. This will cause a bag to advance slowly and stop.

Step 2: Press the <JOG+> button to advance the perforation on the bag to light up with the heater bar.

Step 3: When the perforation is in alignment with the heater bar, press the <Zero Seal> button.

Step 4: Press the <JOG - > button to reverse the bag into the machine, so that the perforation stops below the fingers on the upper roller.

This procedure also sets the max distance that the bag can reverse so that the bag web does not break due to reversing too much into the machine.

To test for accuracy of the Zero Perf Setup Routine (seal point settings), go to the Bag Setup Screen and enter the Minimum seal point value and test cycle the bag. A seal should be positioned immediately below the opening of the bag. The front layer will most likely not be sealed to the back layer.

Then, to test for accuracy of the Zero Perf Setup Routine (Mx Reverse), go to the Bag Setup Screen and enter a Maximum reverse value and test cycle the bag. The bag should not feed to far back into the machine. A Help screen is also available from this screen . See Fig. 3-77

3.52 PLC Info

The PLC I/O screen is provided for maintenance personnel to determine the status of the PLC and review the mode of Outputs and Inputs. PLC I/O screen(s) are also used to assist APPI Service Technicians, working with your Maintenance Personnel to troubleshoot the T-1000 in the field. See Fig.3-78.

To determine the function of each Input / Output, press the LED to display a brief description. The PLC I/O screen also provide the run Hours and Cycles counters. These counters cannot be reset by the operator.

3.53 Information Screens / Message Screens

The T-1000 touch screen program provides for many informational screens that provides descriptions of functions or screens. See Fig. 3-79 through 3-101 for examples of messages that indicate the status of the bagger. Some messages provide functional messages that describe errors or the status of equipment and some provide instructions for operators to follow to bring the bagger back online.

To reset a message screen, clear the condition first (if required) and then touch the screen.

Accumulating Funnel

Please check the following:

- * Air Pressure
- * Electrical connection.
- * Refer to manual for more info

Touch screen to continue

Fig. 3-79

Auxiliary Error

Check Auxiliary equipment
Or turn Auxiliary Option off.

Touch screen to continue

Fig. 3-80

Bag Opener Error

- * Refer to manual for more info

Press Foot switch or
touch screen to continue

Fig. 3-81

Bagger Error

Anti-Jam Triggered

Please check the following:

- * Is seal bar area obstructed?
- * Refer to manual for more info

Touch screen to continue

Fig. 3-82

Bagger Error

Bag Sensor Activated

Please check the following:

- * Are bags threaded properly?
- * Refer to manual for more info

Touch screen to continue

Fig. 3-83

Bagger Error

Open Thermocoupler Signal

Please check the following:

- * Is thermocoupler wire intact?
- * Refer to manual for more info

Touch screen to continue

Fig. 3-84



Fig. 3-85



Fig. 3-86

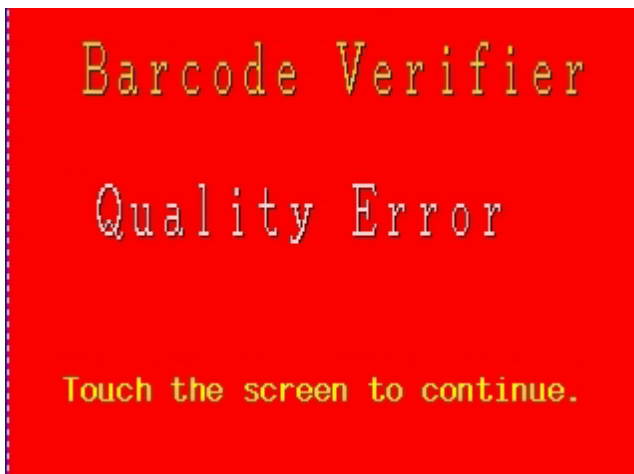

Fig. 3-87



Fig. 3-88



Fig. 3-89

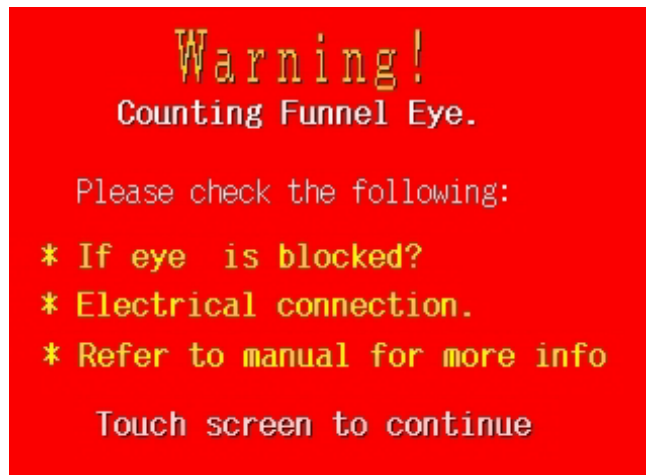

Fig. 3-90



Fig. 3-91



Fig. 3-92



Fig. 3-93



Fig. 3-94

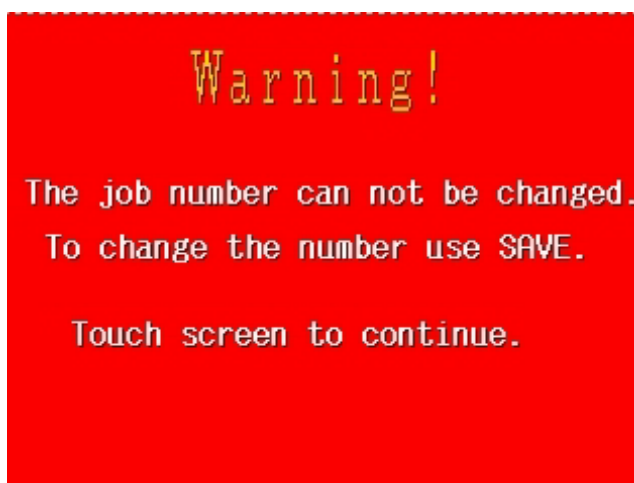

Fig. 3-95



Fig. 3-96



Fig. 3-97



Fig. 3-98



Fig. 3-99



Fig. 3-100

Chapter 4, Settings & Adjustments

Machine Adjustments

Component Replacement

4.1 Machine Adjustments

Periodically, the T-1000 will require readjustment or realignment of components to ensure proper operation. Adjustments may be required after transportation, excessive handling, or due to normal wear and tear.

Caution: Machine adjustments, electrical troubleshooting and component replacement should be performed by qualified maintenance technicians, familiar with safety practices including but not limited to equipment lock-out/tag-out, voltages, and pneumatics. If you are not familiar with the equipment or have not received training on the T-1000, you should consult with APPI technical support before attempting adjustments or repairs.

4.2 Tracking and Alignment Adjustments

To avoid spillage of product in an automatic loading operation and loss of production in a manual loading operation, make machine adjustments to correct the tracking and alignment of the web of bags.

4.3 Compression (NIP) Roller Adjustment

The drive roll compression is the force that exists between the two feed rolls (rubber covered grooved roll and grooved steel roll). Not enough drive roll compression will prevent the bags from *tearing off* after each sealing operation. Too much drive roll compression will cause extra wear on the drive roll and the motor.

Turn the power switch to the OFF position and unplug the power cord. Remove the left and right side covers. The compression adjustment is located on the lower outside right and left side-plates (Fig. 4-14 & Fig. 4-15).

Compression adjustment is a two step process. First, the upper and lower roller are adjusted to make the lower roller parallel to the upper roller. Then, the lower roller is adjusted (raised) for proper compression.

On both the left panel and right panel, loosen the two locking bolts on the upper block of the compression tension assembly. Loosen the nut on the adjustment screw. With the inner frame locked in the UP position, lower the lower roller by turning the adjustment screws counter-clock wise until the lower roller is parallel to the upper roller and leaving 1/16" gap between the rollers. Turn the adjustment screw clockwise alternatively, keeping the lower roller parallel with the upper roller until the rollers come in contact across the width of the rollers. Slightly lower the inner frame and raise again to ensure that when raised again, the rollers touch simultaneously. Then "snug" the upper block bolts and recheck the alignment.

Note (TIP): A light source (lamp) positioned to the rear of the T-1000 showing light in the gap of the rollers will assist in judging whether the upper and lower roller are parallel.

With the rollers slightly touching and parallel, turn each adjustment screw approximately 1/2 turn clockwise. Then test the compression by putting a bag between the rollers. Attempt to pull the bag between the rollers. If the bag pulls out easily, turn the compression adjustment screws 1/2 turn clockwise.

Continue this adjustment until the bag is slightly difficult to pull out of the rollers.

Caution: Over-tightening of the compression adjustment screws may cause damage to the upper (rubber) roller or the motor

When you are satisfied with the compression, slightly lower the inner frame and slowly raise it until it almost touches the upper roller. If the gap is consistent across the width of the rollers and it appears

LEFT SIDE PANNEL

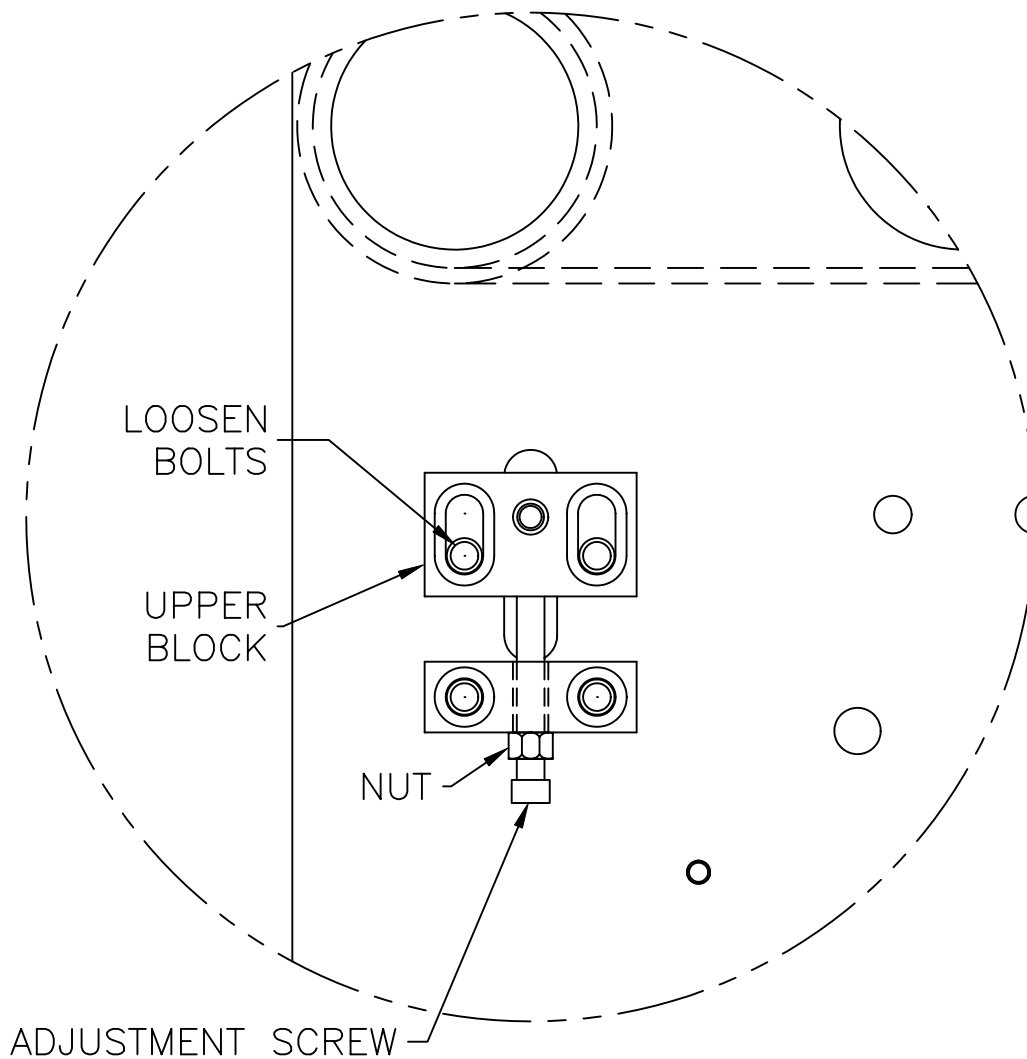

QUANTITY	-	FIGURE 4-14		
MATERIAL	-	 Advanced Poly Packaging Inc. <small>1331 Emmitt Road * Akron * Ohio 44306 Phone: 330-785-4000 * Fax: 330-785-4010</small>		
FINISH	-		TYPE EQUIPMENT	B/M REF. NO.
TOLERANCES UNLESS OTHERWISE NOTED: +/- .015 ON FRACTIONAL DIMENSIONS +/- .010 ON TWO PLACE DECIMAL DIMENSIONS +/- .003 ON THREE PLACE DECIMAL DIMENSIONS 125 ✓ ON MACHINED SURFACES ALL DIMENSIONS ARE IN INCHES PART MUST BE FREE OF BURRS AND SHARP EDGES		T-1000		-
		SCALE	DRAWN BY	APPROVED
		1:1	NAME MELODY	NAME
			DATE 12/05/01	DATE
NOTICE: THIS DOCUMENT CONTAINS PROPRIETARY INFORMATION AND IT SHALL NOT BE USED OR REPRODUCED OR IT'S CONTENT DISCLOSED, IN WHOLE OR PART, WITHOUT THE PRIOR WRITTEN CONSENT OF ADVANCED POLY-PACKAGING INC.		TITLE	DRAWING NO.	REV.
		COMPRESSION (NIP) ROLLER ADJUSTMENT	TP-T1E08	-

RIGHT SIDE PANNEL

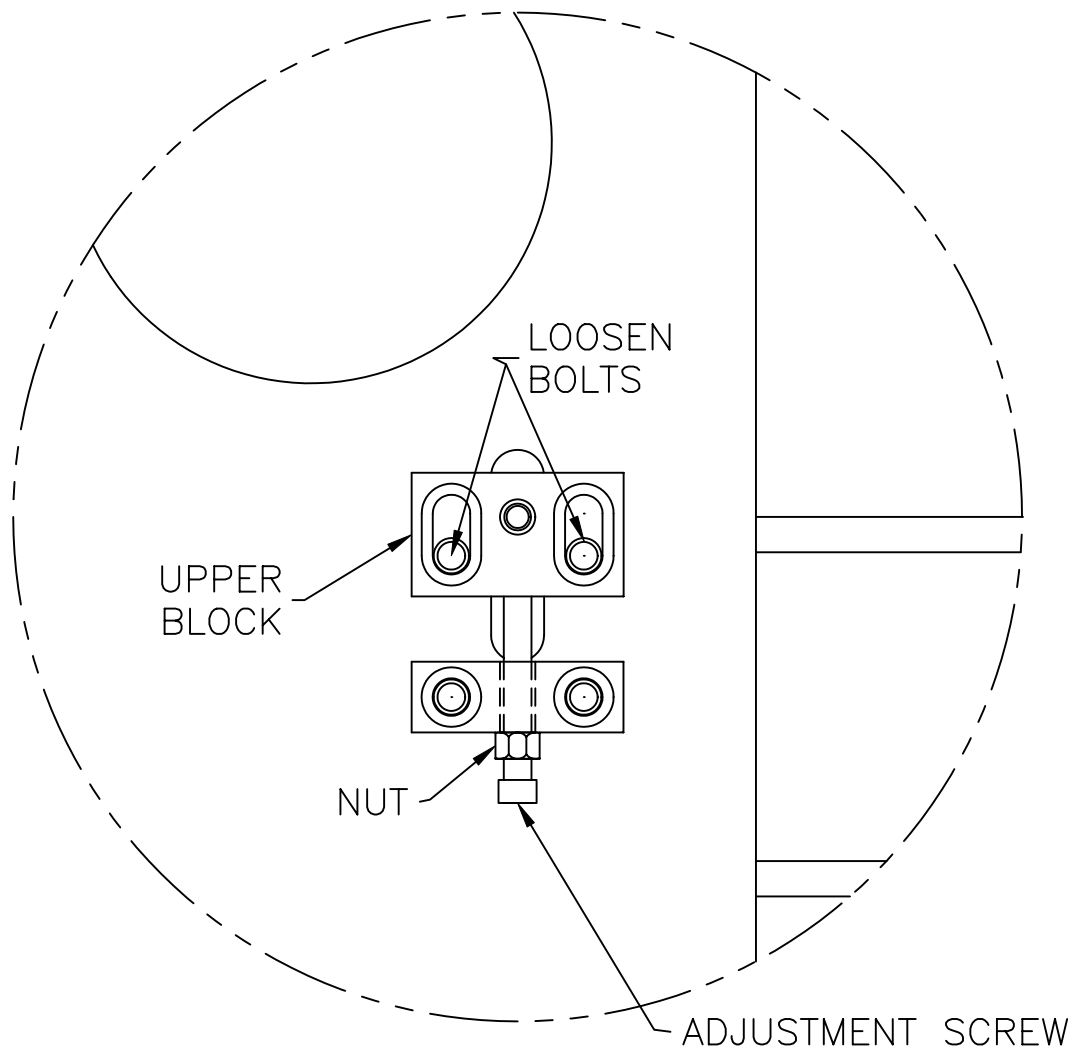

QUANTITY		-		FIGURE 4-15			
MATERIAL		-		 Advanced Poly Packaging Inc. 1331 Emmitt Road * Akron * Ohio 44306 Phone: 330-785-4000 * Fax: 330-785-4010			
FINISH		-		TOLERANCES UNLESS OTHERWISE NOTED: +/- .015 ON FRACTIONAL DIMENSIONS +/- .010 ON TWO PLACE DECIMAL DIMENSIONS +/- .003 ON THREE PLACE DECIMAL DIMENSIONS 125 ✓ ON MACHINED SURFACES ALL DIMENSIONS ARE IN INCHES PART MUST BE FREE OF BURRS AND SHARP EDGES			
		TYPE EQUIPMENT		B/M REF. NO.		PART NO.	
		T-1000				-	
		SCALE		DRAWN BY		APPROVED	
		1:1		NAME MELODY		NAME	
				DATE 12/05/01		DATE	
NOTICE: THIS DOCUMENT CONTAINS PROPRIETARY INFORMATION AND IT SHALL NOT BE USED OR REPRODUCED OR IT'S CONTENT DISCLOSED, IN WHOLE OR PART, WITHOUT THE PRIOR WRITTEN CONSENT OF ADVANCED POLY-PACKAGING INC.		TITLE		DRAWING NO.		REV.	
		COMPRESSION (NIP) ROLLER ADJUSTMENT		TP-T1E07		-	

parallel, lock the inner frame upward and re-tighten the two locking bolts on the upper block of the compression tension assembly. Then re-tighten the nut on the adjustment screws. Replace the covers, plug the cord into the power outlet and turn the main power on.

4.4 Dancer Assembly Adjustments (Roller Shaft)

A roller shaft, holding in position a roll of bags, will rest on the side-plates of the dancer assembly. The roller shaft must be parallel to the upper and lower guide rollers to allow proper tracking through the center of the T-1000. If the roller shaft is not parallel, the web of bags may track to the left or right.

Note: The roller shaft should not be out of alignment unless damaged or jolted in shipment.

4.5 Dancer Bar & Brake Strap Adjustment

The dancer assembly maintains proper bag web tension throughout the stop/start feed motion. T-1000 web tension is required for proper tracking. If the tension is insufficient, the web may track left or right. Thinner bags require less tension than thick bags. Web tension is created by friction of the brake strap along with the weight of the dancer bar pulling downward on the web of bags. Friction of the brake is created by the weight of the bag roll and the spring tension on the brake strap. As the dancer bar raises, spring tension is decreased and friction is decreased. If the web of bags is slack between the dancer roller and nip rollers, there is not enough tension on the bags. If the web of bags break prematurely, the tension is too high.

To correct the web tension, the dancer bar or brake strap spring must be adjusted (Fig. 3-16). To increase brake strap tension, relocate the spring on the dancer rail, by sliding the block closer to the dancer roller. To decrease tension with the brake strap move the spring on the dancer bar, slide block back away from the dancer roller.

The dancer bar pivots on two shoulder bolts which extend from the side-plates. The downward force can be adjusted by repositioning the pivot point. To increase tension with the pivot position, move the pivot position away from the dancer roller. To decrease tension, move the pivot position closer to the dancer roller.

Note: Inspect the dancer bar to ensure that it is parallel to the roller shaft.

4.6 Upper Roller Guides

Two plastic web guides, are located on the upper rear roll of the T-1000 used for *fine* adjustment of tracking. Once the web is tracking within +/- 1/8" left to right, the plastic web guides can be used to further assist tracking. Hold the upper roller in place while turning and sliding the plastic guides close to the bags without touching the bags.

NOTE: If the bags are not tracking properly, the plastic guides could cause the bag web to turn or fold over. If this occurs, slide the guides further away from the web and make adjustments to correct tracking issues.

NOTE: If bags have an air relief hole or hanger hole, shift the bag to the right or left of center to avoid having the hole pass directly under the perf sensor.

NOTE: Use the web guides for minor adjustments only. Major adjustment of the guides requires relocation of the bag roll on the bag roll shaft.

4.7 PTFE Anti-Sticking Adjustment

A PTFE Anti-Sticking sheet which prevents the bag from sticking to heater bar surfaces is located immediately behind the front plate. The material should periodically be inspected for wear or damage. If holes or tears exist, the rolls can be turned (rotated) to cover the contact surfaces with a fresh surface. If a change of material is required, turn the main power to the OFF position and unplug the power cord. Lower the inner frame by pulling the handle downward. The rollers are located on the outside lower frame, on the left and right side of the inner frame which extends beneath the side-plates (Fig. 4-17). To adjust the sheet, turn the lower roller clockwise approximately 1/4 turn using a flathead screwdriver. When fresh material is in place, turn the roller counterclockwise releasing ALL of the tension on the sheet.

CAUTION: If sheet tension is not released, the material will tear when the seal bar engages.

4.8 PTFE Anti-Stick Replacement

Turn the power to the OFF position and unplug the power cord. Remove the four screws which hold the front plate to the inner frame. Pull the front plate from the inner frame and slide the front plate along the guide rods away from the seal assembly. Then slide the rollers and the roller holder away from the heater bar as a unit. Remove and discard the sheet. Replace the sheet and rollers with the new material wrapped on the upper roller. Place the rollers on the roller holder, ensuring springs are seated in the grooves on the rollers. Replace the rollers and holder as an assembly (with the unexpanded material on the upper roller). Replace the front plate and tighten the four screws. Adjust the sheet as described in the previous section.

Note: Fiber spacers are located behind the front gripper plate which may fall when removing the front plate screws.

4.9 Pressure Bar Adjustment

The pressure bar, when actuated by the seal cylinder, is forced against the front plate. The pressure bar must be parallel to front plate to avoid excessive wear of components.

Turn the power to the OFF position and unplug the power cord. Remove the air line from the regulator and remove the top cover. Once the air is removed, the pressure bar can freely be pushed toward the front plate. As the pressure bar approaches the front plate, you can see whether the pressure bar is parallel to the front plate. If it is not, remember which side of the pressure bar touches first; along with the distance of the gap on the opposite side. To make the pressure bar parallel to the front plate, the rear channel which holds the guide rods, must be adjusted. Loosen the nuts inside the channel. On the side opposite of the "touching" side, turn the nut, located on back side of the channel, clockwise the same distance the pressure bar was out of alignment. Tighten the inner-channel nuts and test the pressure bar again by sliding it in and out a few time. Ensure it is parallel to the front plate by slowly pushing it against the front plate. Readjust the nuts on the rear channel as required.

Note: Pressure bar adjustment should only be necessary after rod or bushing replacement.

4.10 Sealer Cylinder Adjustment

Two "speed controls" operate the speed of the cylinder in and out motion that brings the pressure bar against the front plate (grripper plate). Increasing the speed of the pressure will increase production. But, if the pressure bar moves in or out too fast causing the pressure bar to "bang", excessive wear will occur. The valve which controls the pressure bar cylinder is located on the main center cylinder on the inner frame (Fig. 4-19). The adjustment knob (B) controls the speed of the pressure bar INWARD (towards the front plate). The adjustment knob (A) controls the speed of the pressure bar OUTWARD (away from the front plate). To decrease the speed of the pressure bar INWARD, turn the knob (B) counter clockwise. To decrease the speed of the pressure bar INWARD, turn the knob (B) clockwise. To increase the speed of the pressure bar OUTWARD, turn the knob (A) counter clockwise. To

RIGHT SIDE

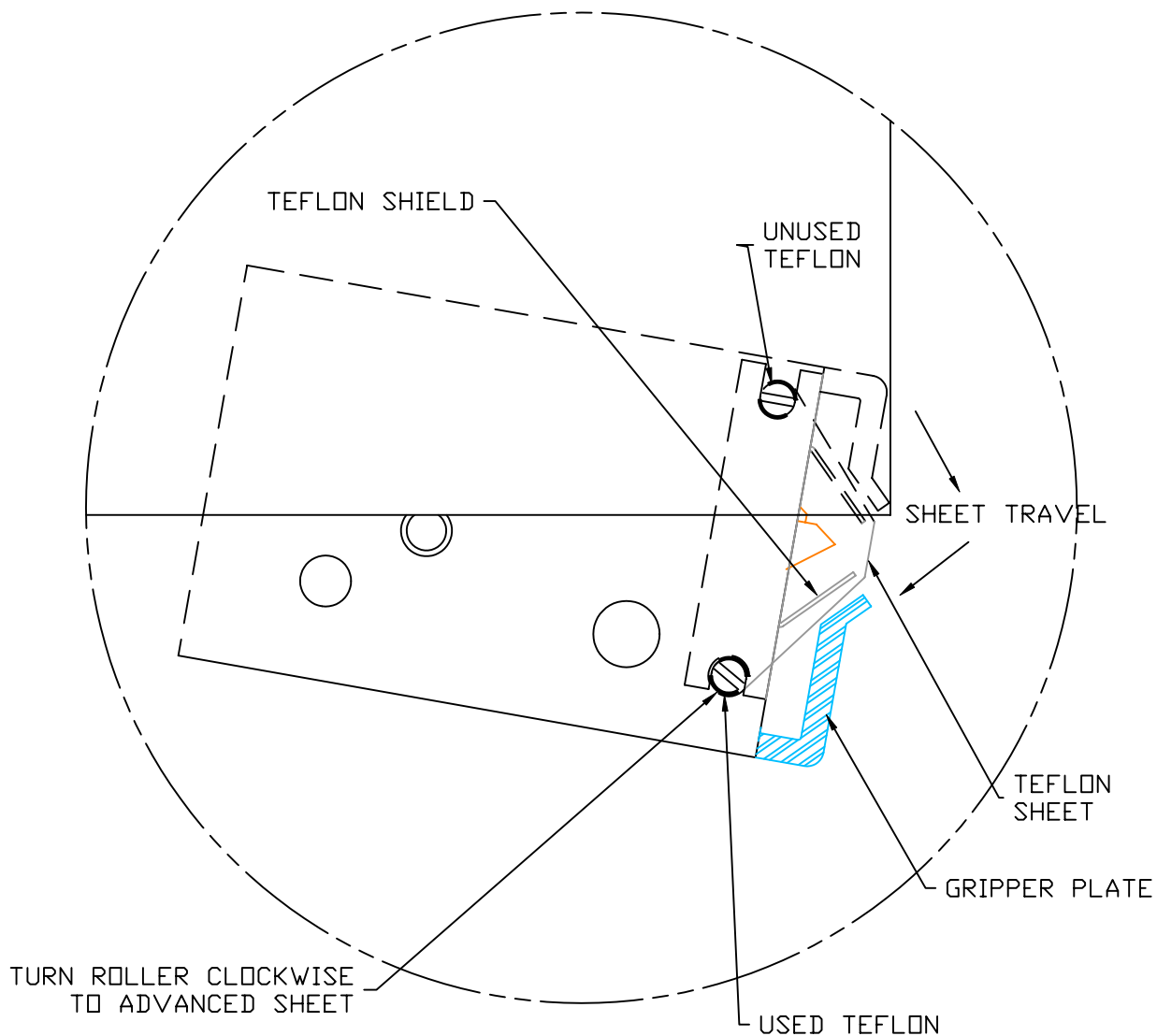

FIGURE 4-17



Advanced
Poly Packaging Inc.

1331 Emmitt Road * Akron * Ohio 44306
Phone: 330-785-4000 * Fax: 330-785-4010

TYPE EQUIPMENT T-1000		B/M REF. NO.	PART NO. -
SCALE NTS		DRAWN BY NAME MELODY DATE 10/23/01	APPROVED NAME DATE
TITLE TEFLON ADJUSTMENT FOR THE T-1000			DRAWING NO. TP-T1T03
NOTICE: THIS DOCUMENT CONTAINS PROPRIETARY INFORMATION AND IT SHALL NOT BE USED OR REPRODUCED OR IT'S CONTENT DISCLOSED, IN WHOLE OR PART, WITHOUT THE PRIOR WRITTEN CONSENT OF ADVANCED POLY-PACKAGING INC.			REV. -

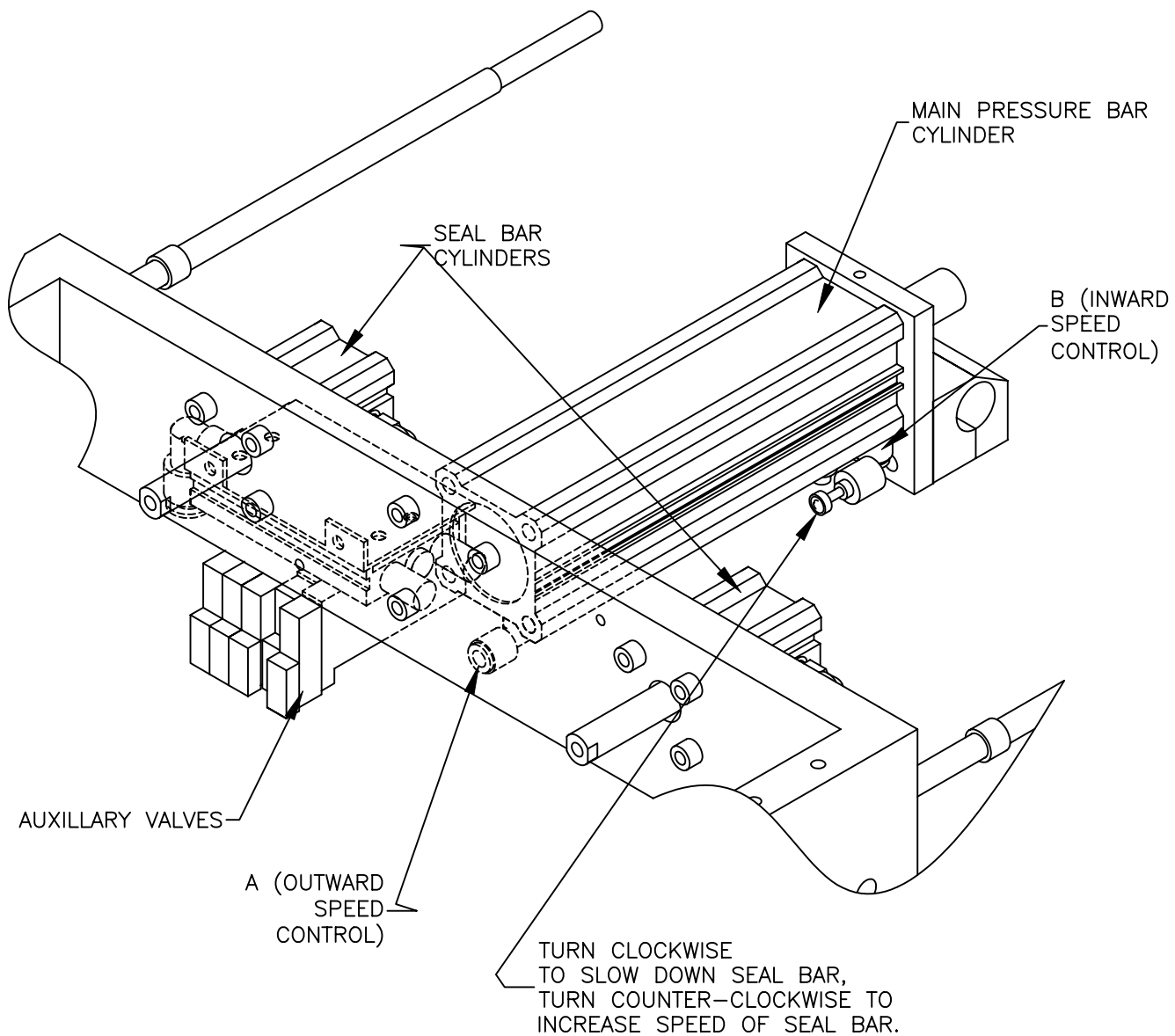

QUANTITY	-	FIGURE 4-19			
MATERIAL	-	 Advanced Poly Packaging Inc. <small>1331 Ewett Road ■ Akron ■ Ohio 44306 Phone: 330-785-4000 ■ Fax: 330-785-4010</small>			
FINISH	-	TYPE EQUIPMENT	B/M REF. NO.	PART NO.	
TOLERANCES UNLESS OTHERWISE NOTED +/- .015 ON FRACTIONAL DIMENSIONS +/- .010 ON TWO PLACE DECIMAL DIMENSIONS +/- .003 ON THREE PLACE DECIMAL DIMENSIONS 125 ✓ ON MACHINED SURFACES ALL DIMENSIONS ARE IN INCHES PART MUST BE FREE OF BURRS AND SHARP EDGES		T-1000		-	
		SCALE	DRAWN BY		APPROVED
		1:1	NAME MELODY	NAME	
			DATE 12/05/01	DATE	
NOTICE: THIS DOCUMENT CONTAINS PROPRIETARY INFORMATION AND IT SHALL NOT BE USED OR REPRODUCED OR ITS CONTENT DISCLOSED, IN WHOLE OR PART, WITHOUT THE PRIOR WRITTEN CONSENT OF ADVANCED POLY-PACKAGING INC.		TITLE	DRAWING NO.	REV.	
		INNER FRAME VALVE ADJUSTMENT	TP-T1B06	-	

decrease the speed of the pressure bar OUTWARD, turn the knob (A) clockwise. Adjust the speed of the pressure bar so that it moves in and out rapidly, in a fluid manner, without causing the pressure bar to "bang" in or out.

4.11 Pressure Bar (Rubber) Replacement

Located along the inside of the pressure bar is a strip of rubber, held on the pressure bar by a channel, pressing on the edges of the rubber. The rubber compresses against the front (gripper) plate holding the bag in place during sealing and during bag tear off. If the rubber becomes brittle, torn, gouged or otherwise worn, it should be replaced to assure strong seals.

To replace the pressure bar rubber, simply pull one end of the rubber from the channel. The rubber will come out of the channel quickly and easily. To install a fresh piece of rubber, press one edge of the rubber into the channel then the other edge. Work the rubber into the channel in small increments along the length of the channel (Fig. 4-20). If you used PTFE tape to cover the surface of the rubber, place the PTFE on the rubber along its length. If the PTFE extends beyond the rubber, cut off the excess.

Note: PTFE may be added to the pressure bar rubber if the bag sticks to the rubber after loading and sealing. The bag may stick to the rubber if the product and bag is light in weight and if the rubber is dirty.

Note: Frequently clean the rubber with alcohol to remove buildup of dirt or other contaminants.

4.12 Antijam Adjustment

The antijam device is designed to protect the T-1000 from damage when an obstruction is encountered in the seal area (area between the pressure bar and front (gripper) plate). If properly adjusted, the pressure bar will retract if an obstruction is encountered in the seal area. The pressure bar houses springs which cause the rubber and holder to compress. When the rubber holder compresses, a sensor is activated causing the pressure bar to retract. The sensor is defeated when the pressure bar is approximately 1/8" from the gripper plate (Fig. 4-21). The antijam can quickly be tested while the T-1000 is operating using care, but should be thoroughly tested by disconnecting air and power and removing covers.

To quickly test the antijam device, place a 3/8" diameter flexible poly tube against the front (gripper) plate perpendicular to the seal bar opening. Press the foot switch allowing the pressure bar to compress the poly tube against the front plate. If the pressure bar does not immediately retract and place the T-1000 in the STOP mode, the antijam device is not properly adjusted. Test the antijam device along the entire length of the pressure bar using the 3/8" poly tubing as a test device.

CAUTION: To avoid personal injury, do not place fingers or hands into the seal area of the T-1000 while power is ON or air is attached. Do not test the antijam device with hands or fingers. Ensure the poly tube which is used for testing is long enough to keep fingers or hands away from the seal area of the T-1000.

To thoroughly test and adjust the antijam device, you must first turn the power to the OFF position, disconnect the air line from the T-1000 and remove the top and left side cover. With the covers removed and air disconnected, turn the power to the ON position.

To test the pressure bar sensor, locate the "X4" LED on the PLC Board (Fig. 4-8) and ensure the light is illuminated (ON). Then, compress the rubber and holder into the pressure bar (nylon holder). As soon as the rubber is pressed into the nylon holder, the "X4" LED should turn OFF. The LED should remain OFF while the rubber is held compressed into the nylon holder. If the "X4" LED shuts OFF while the rubber bar is pressed into the nylon holder, the pressure bar sensor is functioning properly.

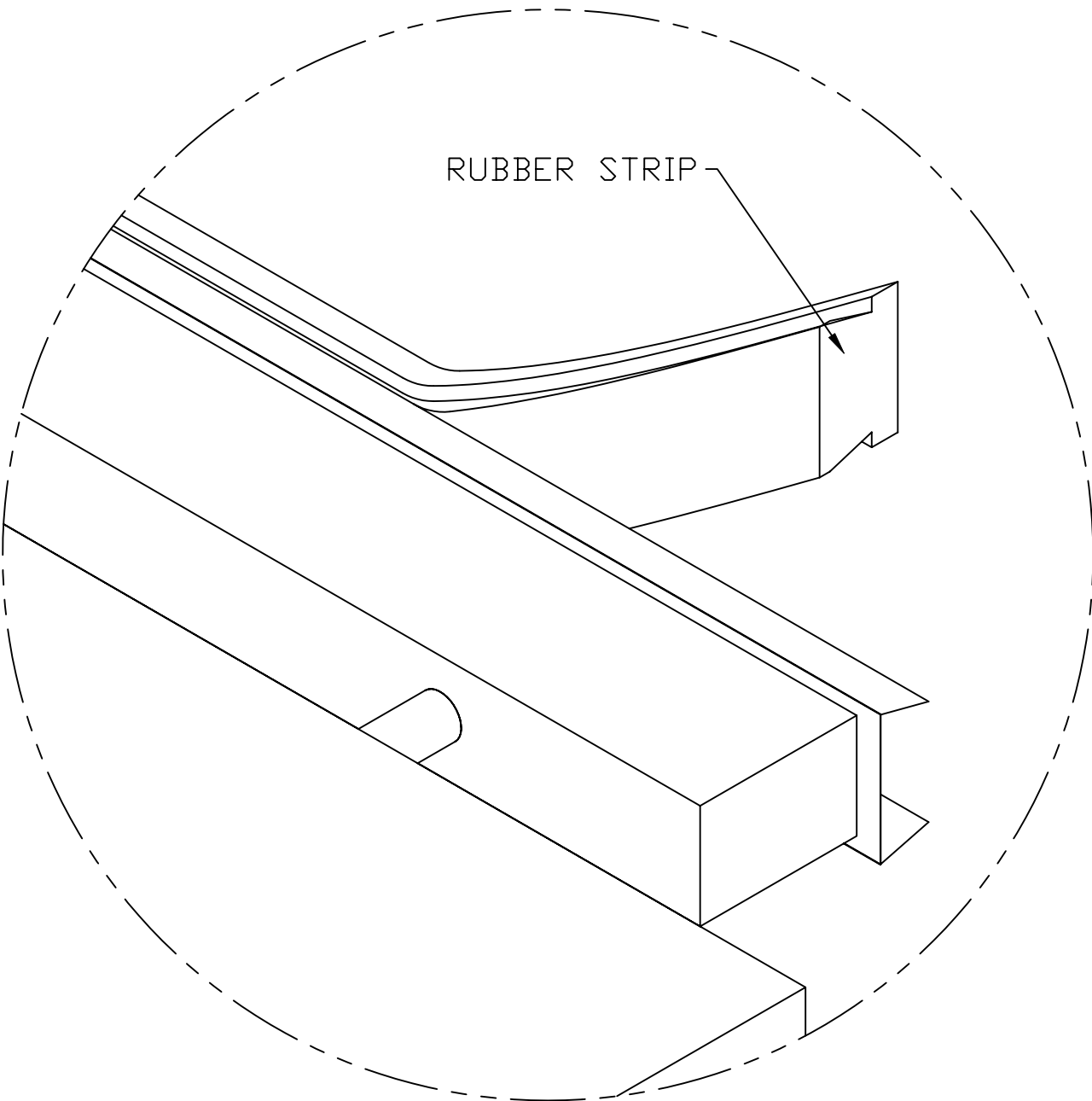

FIGURE 4-20

QUANTITY	-
MATERIAL	-
FINISH	-



Advanced
Poly Packaging Inc.

1331 Emmitt Road * Akron * Ohio 44306
Phone: 330-785-4000 * Fax: 330-785-4010

TOLERANCES UNLESS OTHERWISE NOTED:

- +/- .015 ON FRACTIONAL DIMENSIONS
- +/- .010 ON TWO PLACE DECIMAL DIMENSIONS
- +/- .003 ON THREE PLACE DECIMAL DIMENSIONS
- 125 ✓ ON MACHINED SURFACES
- ALL DIMENSIONS ARE IN INCHES

PART MUST BE FREE OF BURRS AND SHARP EDGES

TYPE EQUIPMENT T-1000	B/M REF. NO.	PART NO. -
SCALE 1:1	DRAWN BY NAME MELODY DATE 12/13/011	APPROVED NAME DATE
TITLE PRESSURE BAR	DRAWING NO. TP-4-20	REV. -

NOTICE: THIS DOCUMENT CONTAINS PROPRIETARY INFORMATION AND IT SHALL NOT BE USED OR REPRODUCED OR ITS CONTENT DISCLOSED, IN WHOLE OR PART, WITHOUT THE PRIOR WRITTEN CONSENT OF ADVANCED POLY-PACKAGING INC.

GUIDE ROD

HOUSING

FRONT GRIPPER PLATE

RUBBER HOLDER CHANNEL

PRESSURE RUBBER

ACORN NUT

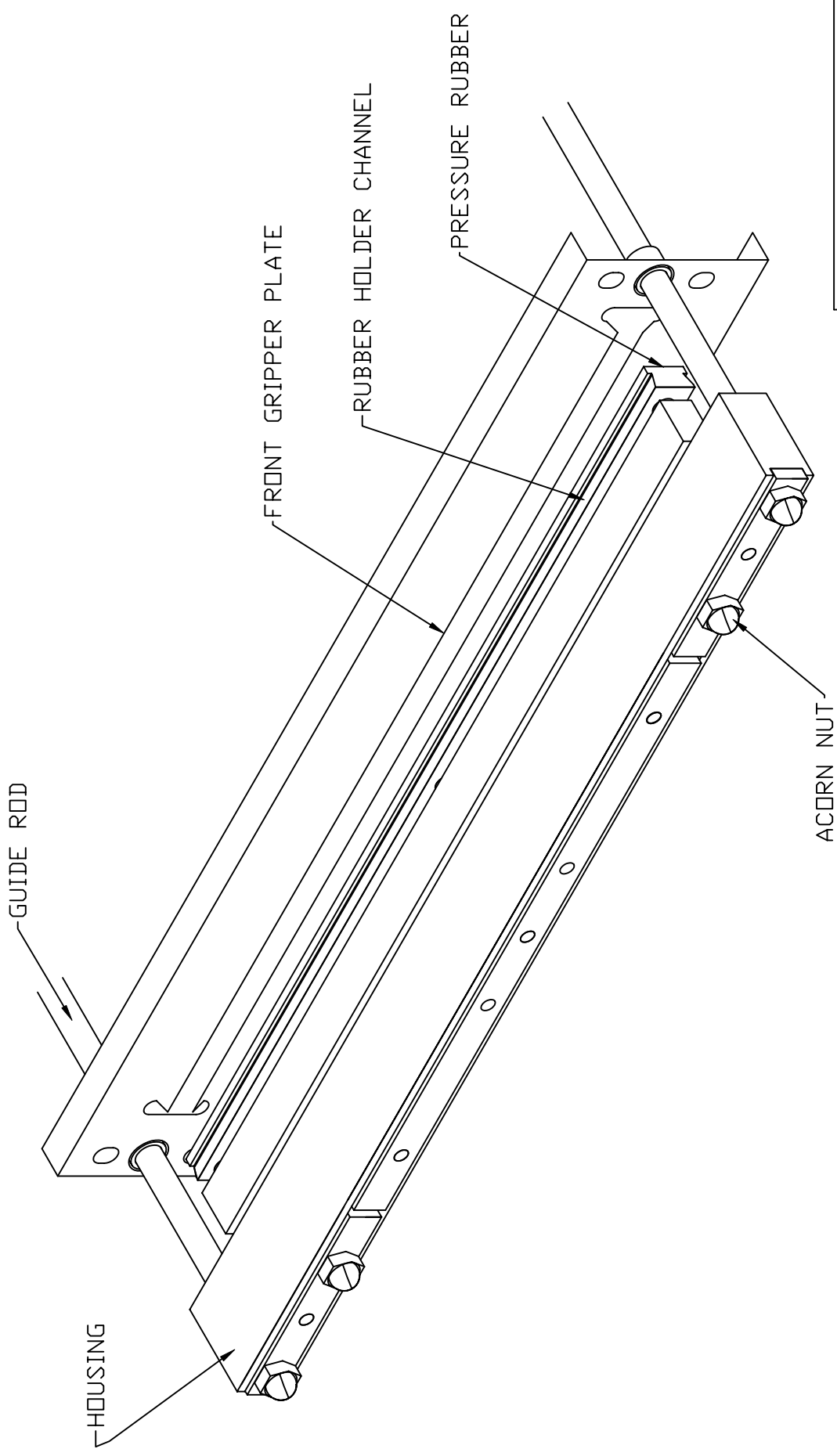

FIGURE 4-21

Advanced
Poly Packaging Inc.

TYPE EQUIPMENT	T-1000	DATE	10/23/01
SCALE	NTS	DRAWN BY	MELODY
		DATE	10/23/01
		APPROVED	
		NAME	
		DATE	
		REV.	

NOTICE: THIS DOCUMENT CONTAINS PROPRIETARY INFORMATION AND IS UNCLASSIFIED. ANY DISCLOSURE OF THIS INFORMATION WITHOUT THE WRITTEN CONSENT OF ADVANCED POLY-PACKAGING INC. IS PROHIBITED.

NOTE: 1/8" GAP BTW. PRESSURE RUBBER AND FRONT GRIPPER PLATE

TITLE ANTI-JAM ADJUSTMENT
 DRAWING NO. TP-T1B02
 REV. -

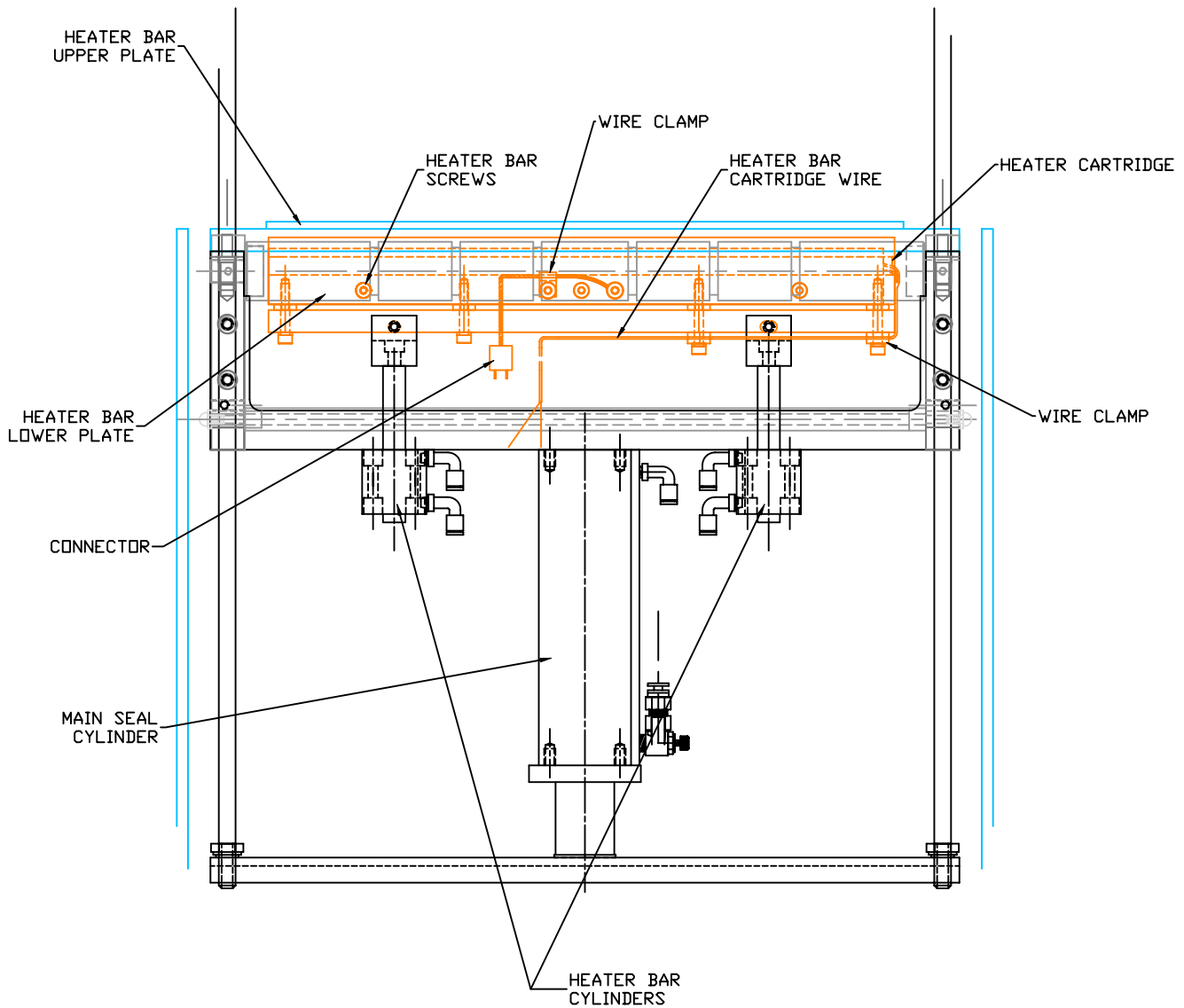

VIEW FROM UNDERNEATH INNER FRAME

FIGURE 4-23



Advanced Poly Packaging Inc.

1331 Ewett Road ■ Alton ■ Ohio 44306
Phone: 330-789-4900 ■ Fax: 330-789-4910

TYPE EQUIPMENT T-1000	B/M REF. NO.	PART NO. -
SCALE 1:2	DRAWN BY NAME MELODY DATE 10/23/01	APPROVED NAME DATE

NOTICE: THIS DOCUMENT CONTAINS PROPRIETARY INFORMATION AND IT SHALL NOT BE USED OR REPRODUCED OR ITS CONTENT DISCLOSED, IN WHOLE OR PART, WITHOUT THE PRIOR WRITTEN CONSENT OF ADVANCED POLY-PACKAGING INC.

TITLE HEATER BAR CARTRIDGE REPLACEMENT DRAWING	DRAWING NO. TP-T1B04	REV. -
---	-------------------------	-----------

To test the antijam override sensor, locate the "X7" LED on the PLC board (Fig. 4-8) and ensure that the light is OFF. Then, standing in front of the T-1000, push the pressure bar slowly towards the front plate, keeping hands and fingers out of the seal area. While pushing the pressure bar towards the front plate do not compress the rubber into the nylon holder or touch the round nuts on the pressure bar (Fig. 4-21).

When the pressure bar rubber is approximately 1/8" from the front plate, "X7" LED should illuminate (ON).

If the LED illuminates prematurely (when the rubber is farther than 1/8" from the front plate), the antijam override sensor must be adjusted. An aluminum block, located on the right guide rod in the inner frame, houses a magnet (Fig. 4-22). The antijam override sensor detects the magnetic field sending the signal to the PLC. If illuminated prematurely, the "magnetic block" should be moved toward the front of the T-1000 along the guide rod.

If the LED illuminates when the rubber is closer than 1/8" to the front plate or when the rubber is touching the rubber plate (illuminates late), the magnetic block should be adjusted by moving the magnetic block toward the rear of the T-1000 along the guide rod.

To move the magnetic block, loosen the screw on the block which secures it to the guide rod. Loosen the screw just enough to allow the magnet block to slide along the guide rod without pivoting.

After moving the magnetic block, pull the pressure bar away from the front plate and check the illumination of "X7" LED by pushing the pressure bar slowly toward the front plate. If out of alignment, move the magnetic block in 1/8" increments until properly positioned. In its final position along the guide rod, the magnetic block should be parallel to the side plate.

If the magnetic block, when parallel to the side plate and adjacent to the override sensor, does not cause the LED to illuminate, adjust the override sensor so that the sensor is closer to the magnetic block.

The override sensor is secured to the side-plate with two plastic nuts, one on either side of the side-plate. To bring the sensor closer to the magnetic block, loosen the nuts and turn the sensor counter clockwise, from inside the frame. Turn the sensor 1/2 turn at a time or until the "X7" LED is illuminated. When illuminated, turn 1/4 turn more.

CAUTION: To avoid damaging the plastic override sensor, position the sensor so that it does not contact the magnetic block when the pressure bar is moving. To avoid "stripping" the threads of the sensor, do not over tighten the securing nuts.

When properly positioned, secure the sensor by tightening the securing nuts. When properly adjusted and thoroughly tested, tighten the screw on the magnetic block, replace covers and connect the air line to the regulator.

4.13 Heater Cartridge Replacement

A cylinder-shaped cartridge (element), located inside the heater bar, heats the bronze bars which contain it. This cartridge is considered a normal wear item and will infrequently fail, requiring replacement.

To determine if the heater cartridge is bad, follow the following troubleshooting steps: 1) Locate the "Y3" indicator on the PLC info screen. See Fig. 3-26. Press the <START> key if the T-1000 is in the Stop mode. If "Y3" illuminates in long pulses without increasing the Temperature on the Bag Setup screen proceed to step two. 2) Check resistance value of heater cartridge, should read between 18-32 ohms.

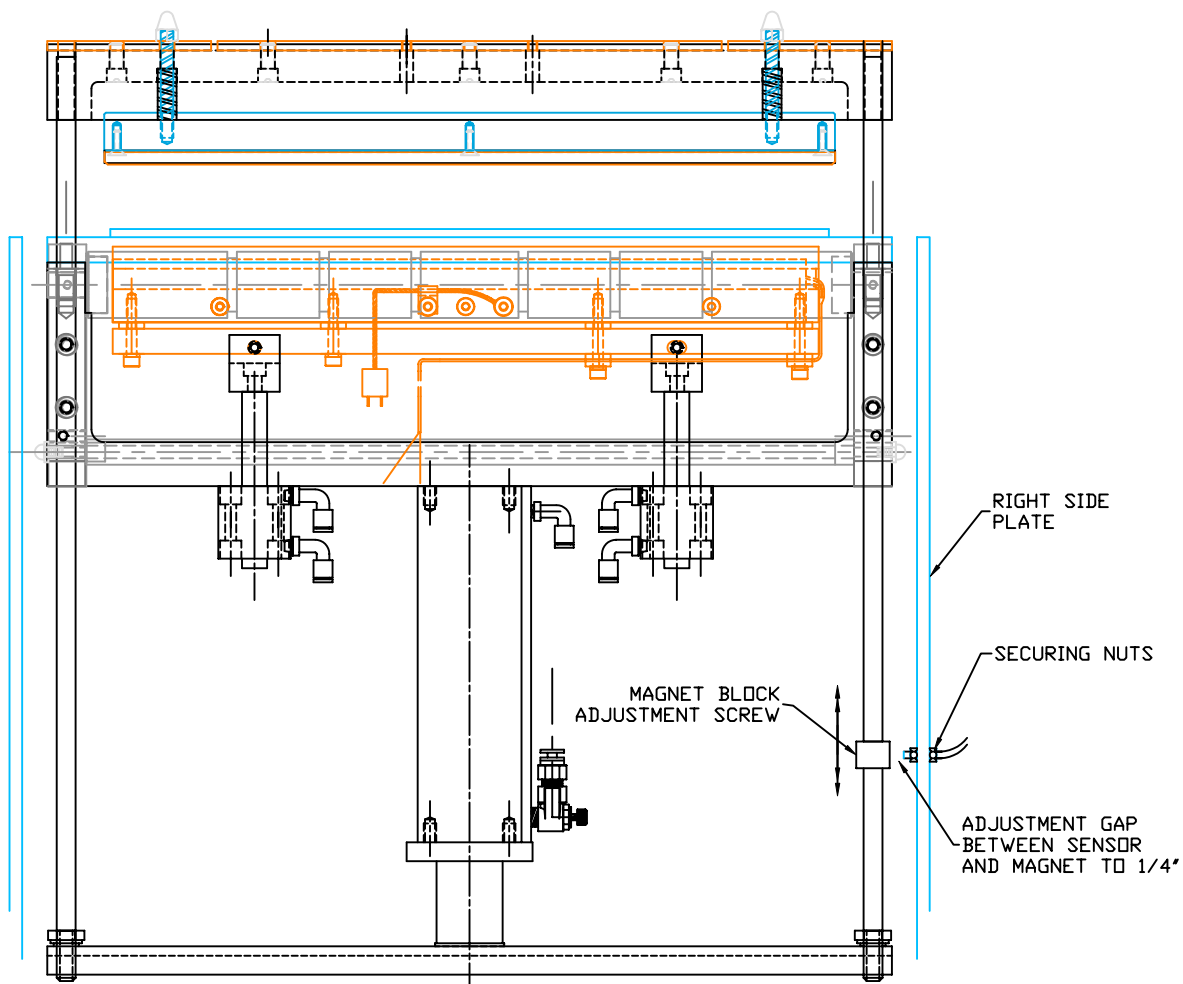

FIGURE 4-22



Advanced Poly Packaging Inc.

1331 Ewitt Road ■ Akron ■ Ohio 44306
Phone: 330-789-4900 ■ Fax: 330-789-4010

TYPE EQUIPMENT T-1000	B/M REF. NO.	PART NO. -
SCALE 1:2	DRAWN BY NAME MELODY DATE 12/05/01	APPROVED NAME DATE

NOTICE: THIS DOCUMENT CONTAINS PROPRIETARY INFORMATION AND IT SHALL NOT BE USED OR REPRODUCED OR ITS CONTENT DISCLOSED, IN WHOLE OR PART, WITHOUT THE PRIOR WRITTEN CONSENT OF ADVANCED POLY-PACKAGING INC.

TITLE ANTI-JAM OVER-RIDE ADJUSTMENT	DRAWING NO. TP-T1B03	REV. -
--	-------------------------	-----------

Note: If you do not have an Ohms meter, replace the heater cartridge after step one.

To replace the heater cartridge, turn the main power to the OFF position, unplug the power cord and disconnect the air line.

Disconnect the heater cartridge wire at the connector. From underneath the inner frame, loosen and remove the screws which holds the wire clamp and lower heater bar plate to the upper heater bar plate (Fig. 4-23). Then remove the two remaining screws which hold the lower heater bar plate to the upper heater bar plate. Remove the heater cartridge wires from the wire clamp. Place a new cartridge into the heater bar slot and replace the lower heater bar plate. Place the wires into the wire clamp and secure to the lower heater bar plate. Reconnect the heater cartridge wires ensuring that the heater bar can extend fully without stretching the heater cartridge wires. Plug the cord into the outlet, turn the power to the ON position and connect the air line to the regulator. Press <START> on the Touch Screen and verify that the temperature increases.

Note: Heater cartridge wires must make a sharp 90° bend at the end of heater bar. Wires should to extend past the end of the heater bar.

4.14 Replace Thermocouple Wire

A thermocouple wire, brazed to a ring terminal and secured to the bottom of the heater bar, detects the amount of heat the heater bar is emitting. The thermocouple wire is considered a normal wear item and will infrequently fail, requiring replacement.

The thermocouple should be replaced when excessive fluctuations occurs or incorrect temperature is displayed in the Bag Setup menu. The thermocouple should also be replaced when a visual inspection reveals frayed insulation or broken wire. If the above conditions are met, the thermocouple is bad and the current to the heater bar has been turned OFF.

To replace the thermocouple wire, turn the main power to the OFF position, unplug the power cord and disconnect the air line.

Remove the front plate and PTFE assembly, as described in Chapter 4.13. Remove the screws which hold the ring terminal and the jacketed wire clamp. Disconnect the connector and remove the wire. Reverse these steps to replace the wire.

CAUTION: To avoid stretching or breaking the wire during heater cylinder extension, ensure that the wire is looped and free to bend during heater bar movement.

Replace the PTFE assembly and front plate.

This page intentionally left blank.

Chapter 5, Parts

Advanced Poly-Packaging, Inc.

Bill of Materials Top Level Report for 5/23/2006

(see Drawing No. T-T1000-S14)

Assembly --> T-T1000-S14 T-1000S Advanced Poly-Bagger (DF14)

Item	Item No.	Description
1	TA-T10100-S14	Head Assembly, T-1000-S14
2	TA-T10199	Stand Assy, T-1000
3	TA-T10240	IOP Control Case Assy

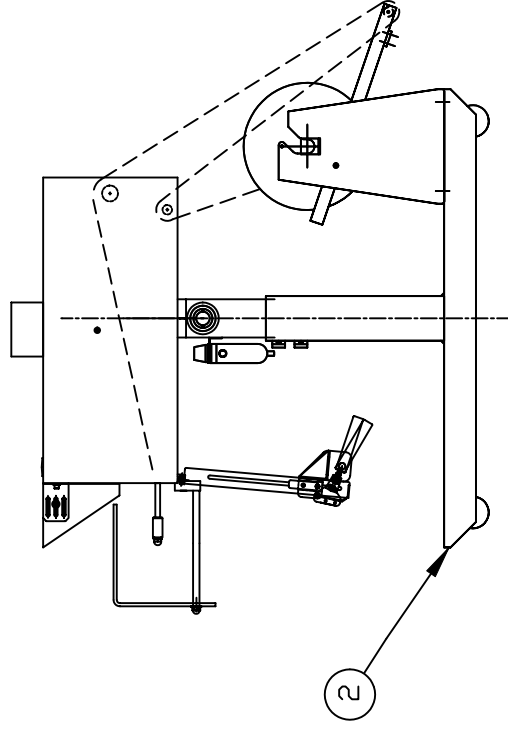
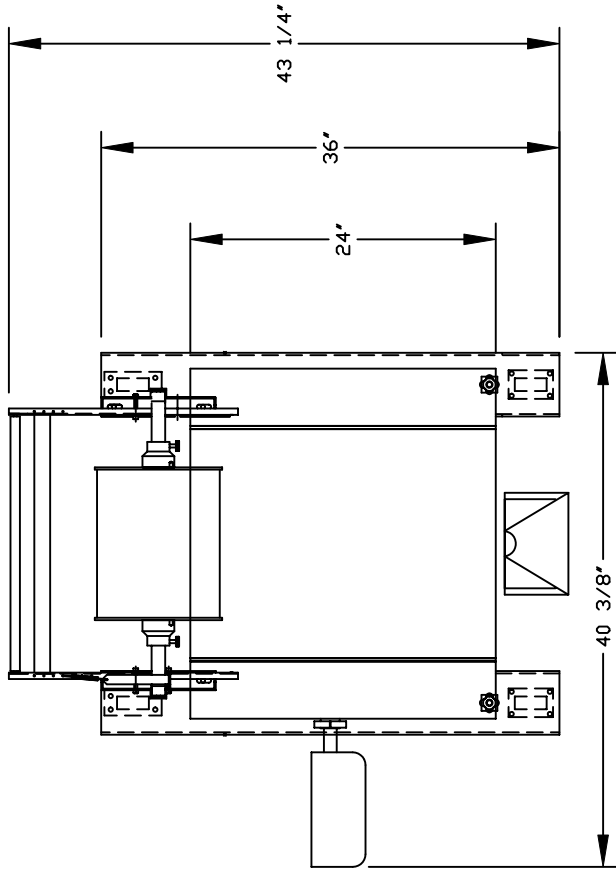

SIDE VIEW

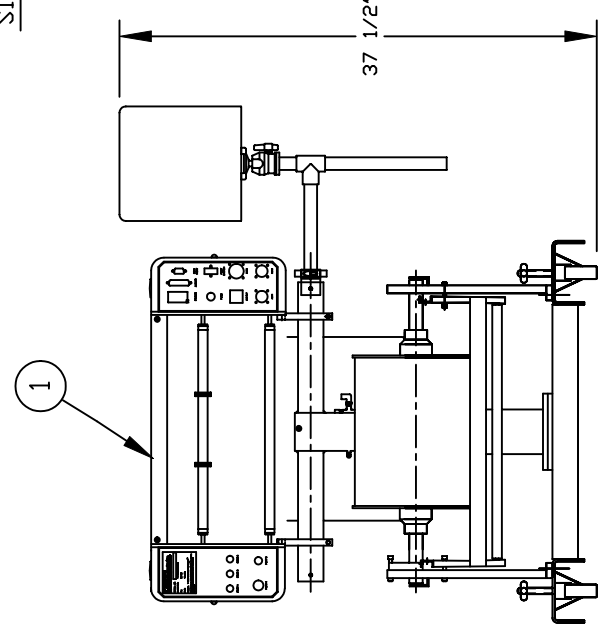

REAR VIEW

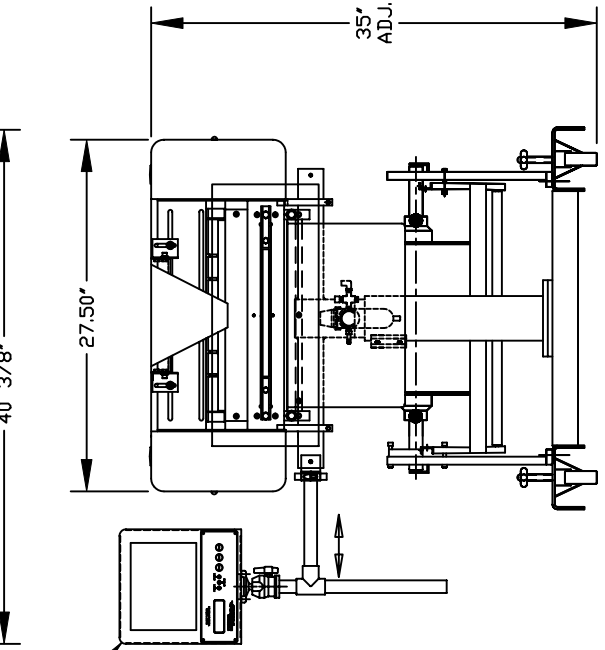

FRONT VIEW

I.D.P. FOR USE WITH
 T-1000B
 T-1000A
 T-1000-S14 V.1 T-2000
 SEE DIMENSIONS FOR DETAILS
 T-1000B FOR DETAILS

QTY	MATERIAL	FINISH	REV	DATE	CHKD	BY	DESCRIPTION
Advanced Poly Packaging Inc. 1000 S. 10th St. - Suite 100 Phoenix, AZ 85001-1000 Phone: 602-998-7800							
TYPE CHANGE: T-1000-S14 T-1000-S14 T-1000-S14 SCALE: NA DATE: 4/10/01 DATE: 4/10/01 DATE: 4/10/01 DRAWN BY: DATE: 4/10/01 DATE: 4/10/01 DATE: 4/10/01 CHECKED BY: DATE: 4/10/01 DATE: 4/10/01 DATE: 4/10/01 APPROVED BY: DATE: 4/10/01 DATE: 4/10/01 DATE: 4/10/01							
TITLE: T-1000-S14 BAGGER MACHINE ASSEMBLY PART NO.: T-1000-S14							
NOTES: THIS DRAWING CONTAINS PROPRIETARY INFORMATION. IT IS TO BE KEPT CONFIDENTIAL AND NOT REPRODUCED OR COPIED WITHOUT THE WRITTEN CONSENT OF ADVANCED POLY-PACKAGING, INC.							

Advanced Poly-Packaging, Inc.

Bill of Materials Top Level Report for 5/23/2006

(see Drawing No. TA-T10100-S14)

Assembly --> TA-T10100-S14 Head Assembly, T-1000-S14

Item	Item No.	Description
1	TA-T10018	Flat Load Shelf Sub-Assembly
2	TA-T10110-S14	Main Frame Assy, TA-T1000-S14
3	PENDING	Pending Item Number or N/A
4	TO-T1-FU-MISC	Additional Funnel for T-1000
5	TP-T1MD00044	Top Cover
6	TP-T1MD00004S14	Cover,Electronics Left Side T1K-S14
7	TP-T1MD00005S14	Cover,Pneumatics Right Side T1K-S14
8	TP-T1MD00116-1	Lexan Guard, T-1000
9	TP-T1MO00226-1	Euro Guard Bracket (Left)
10	TP-T1MO00226-2	Euro Guard Bracket (Right)
11	TP-T1MD00201-1	Funnel Mounting Bracket Left
12	TP-T1MD00201-2	Funnel Mounting Bracket Right

TOP VIEW

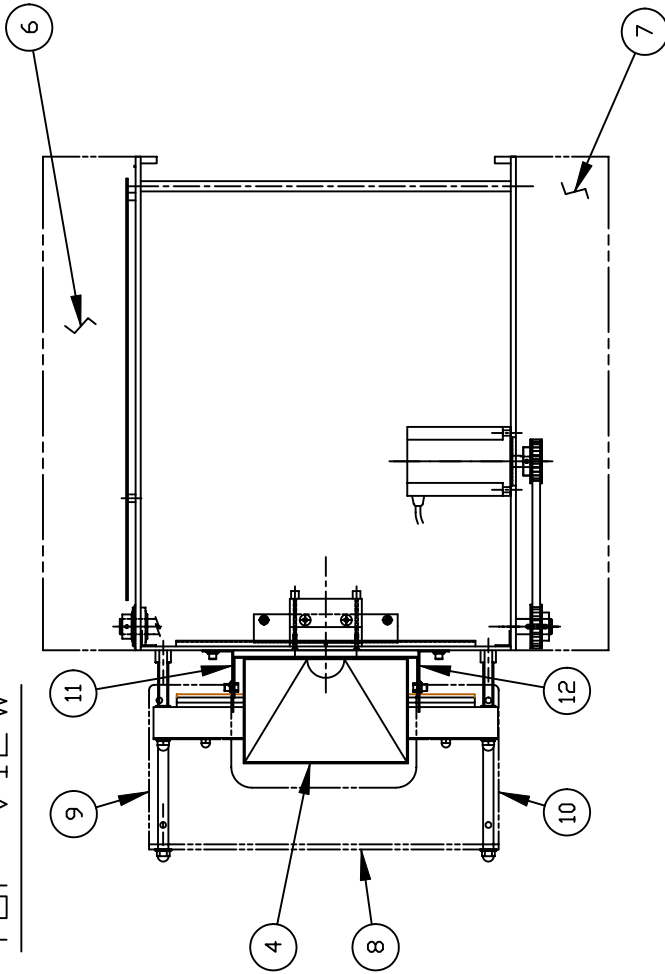

SIDE VIEW

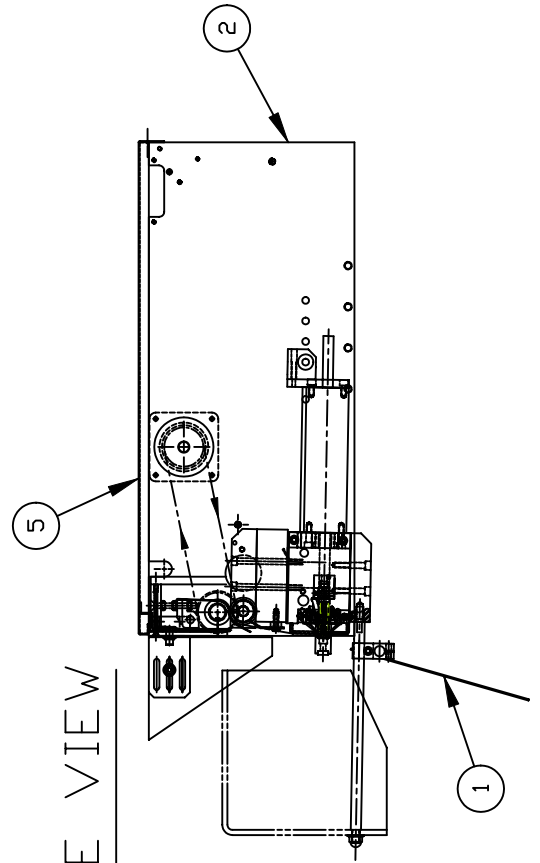

QUANTITY		REV	DATE	BY	DESCRIPTION
MATERIAL					
FINISH					
<p>USE ENGLISH UNITS IN ALL DIMENSIONS UNLESS OTHERWISE NOTED 1/2" AND ON FRACTIONAL DIMENSIONS 1/4" AND ON TWO PLACE DECIMAL DIMENSIONS 1/8" AND ON THREE PLACE DECIMAL DIMENSIONS ALL DIMENSIONS ARE IN INCHES PART MUST BE FREE OF BURRS AND SHARP EDGES</p> <p>NOTED: THIS DOCUMENT CONTAINS PROPRIETARY INFORMATION AND IT SHALL NOT BE USED OR REPRODUCED OR ITS CONTENTS DISCLOSED TO ANY OTHER PERSON WITHOUT THE WRITTEN CONSENT OF ADVANCED POLY-PACKAGING INC.</p>					
<p>Advanced Poly Packaging Inc. 1520 Everett Road • Houston • TX 77061-4000 PHONE: 281-282-2200 FAX: 281-282-2201</p>		<p>TYPE EQUIPMENT: T-1000-S14 SCALE: 1:4 DRAWN BY: [blank] INK: CJK DATE: 7/12/05</p>			
		<p>TITLE: HEAD ASSEMBLY PART NO.: TA-T10100-S14 DRAWING NO.: TA-T10100-S14</p>			

Advanced Poly-Packaging, Inc.

Bill of Materials Top Level Report for 5/23/2006

(see Drawing No. TA-T10018)

Assembly --> TA-T10018

Flat Load Shelf Sub-Assembly

Item	Item No.	Description
1	TP-T1MB00074-1	Load Shelf Bracket (Left)
2	TP-T1MB00074-2	Load Shelf Bracket (Right)
3	TP-T1MB00075	Back Plate, 14"W x 9"L, Fixed Plate
4	TP-T1MB00076	Rod, Fixed Load Shelf
5	TP-101102	Nut, 6-32 Hex Mach Screw Pltd
6	TP-102152	Washer, #6 Med Split Lock
7	TP-102155	Washer, 1/4 Med Split Lock
8	TP-103003	Screw, SHCS 1/4-20 x 1/2
9	TP-103224	Screw, BHCS 1/4-20 x 1/2
10	TP-103407	Screw, FHCS 6-32 x 3/4

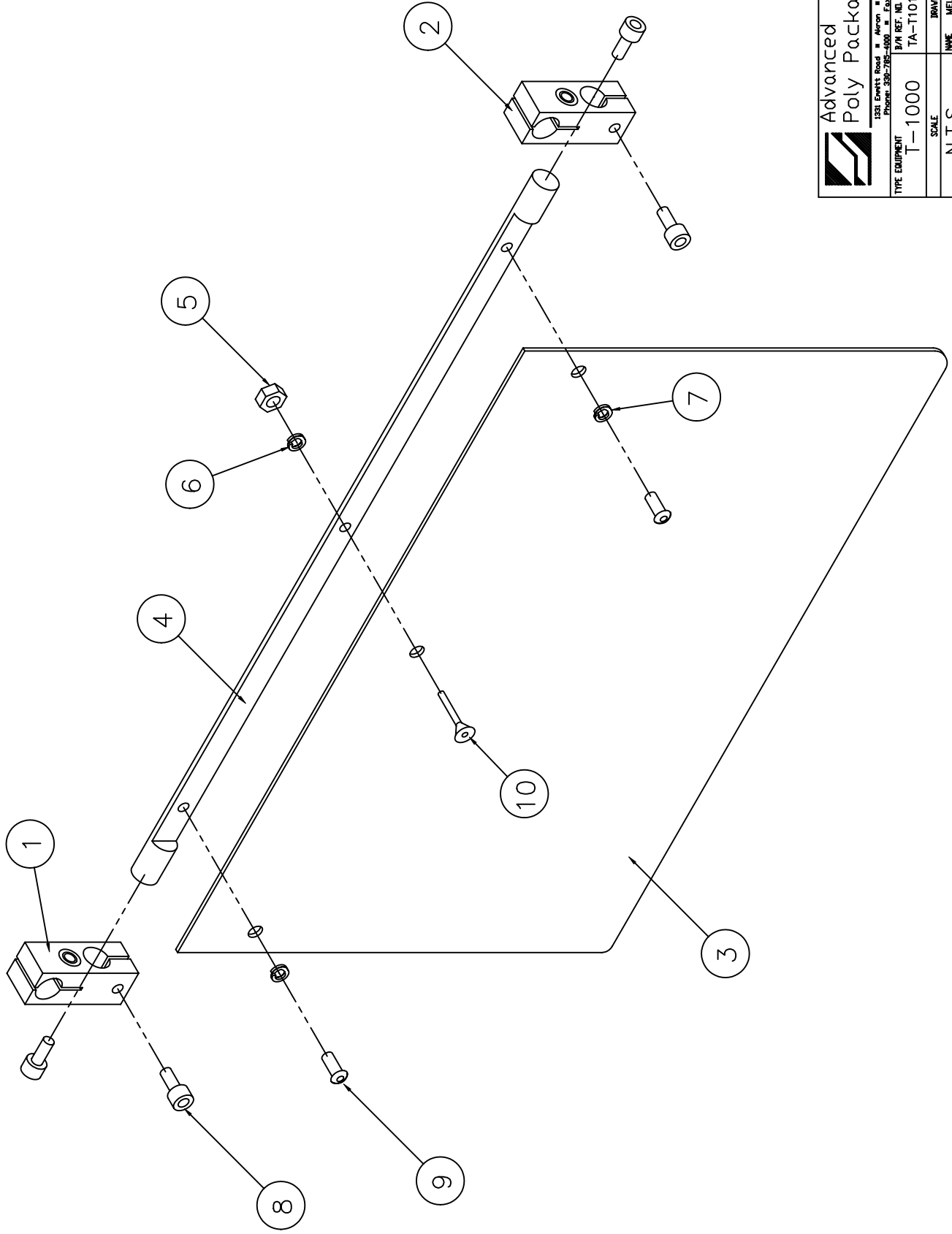

Advanced Poly Packaging Inc.
 1331 Everett Road ■ Akron ■ Ohio 44396
 Phone: 330-785-4000 ■ Fax: 330-785-5000

TYPE EQUIPMENT	T-1000	PART NO.	TA-T10018
SCALE	N.T.S	DATE	7/26/00
DATE		NAME	MELODY
DRAWN BY		NAME	MELODY
APPROVED		DATE	
DRAWING NO.			TA-T10018
TITLE			FLAT LOAD SHELF SUB-ASSEMBLY
REV.			

NOTICE: THIS DOCUMENT CONTAINS PROPRIETARY INFORMATION AND SHALL NOT BE USED OR REPRODUCED OR ITS CONTENT DISCLOSED IN ANY MANNER WITHOUT THE PRIOR WRITTEN CONSENT OF ADVANCED POLY-PACKAGING, INC.

Advanced Poly-Packaging, Inc.

Bill of Materials Top Level Report for 5/23/2006

(see Drawing No. TA-T10110-S14)

Assembly --> TA-T10110-S14 Main Frame Assy, TA-T1000-S14

Item	Item No.	Description
1	TA-T10250-S14	Main Frame Assy, T-1000-S14
2	TA-T10270-S14	Electrical Panel, T-1000-S14
3	TA-T10280-S14	Sealer Frame Assy, T-1000-S14

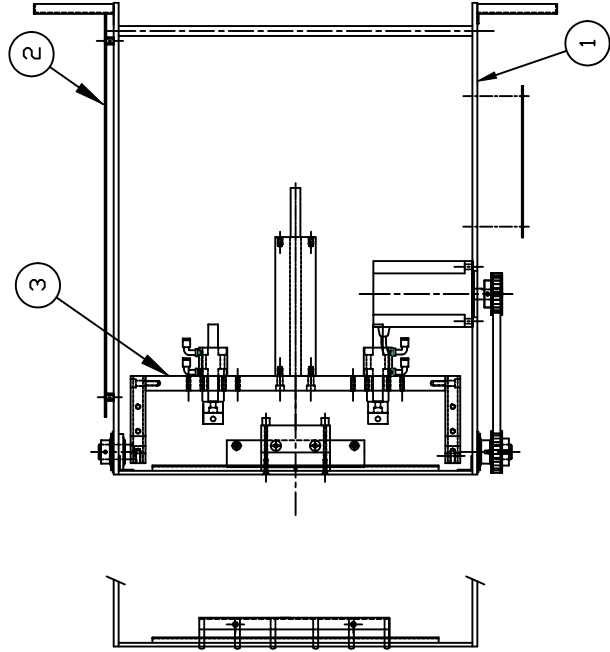
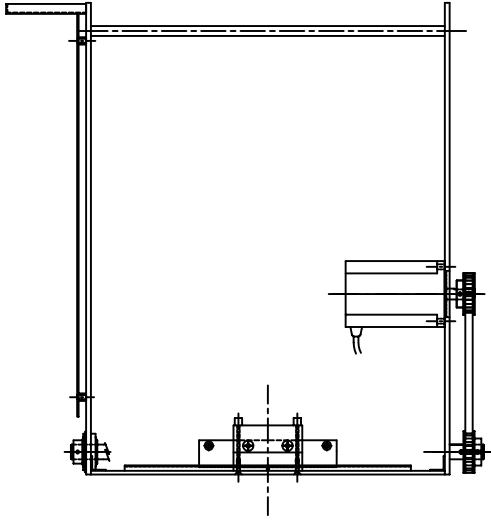

QUANTITY					
MATERIAL					
FINISH					
<p>TOLERANCES UNLESS OTHERWISE NOTED 1/4" AS ON FRACTIONAL DIMENSIONS 1/8" AS ON TWO PLACE DECIMAL DIMENSIONS 1/16" AS ON THREE PLACE DECIMAL DIMENSIONS ALL DIMENSIONS ARE IN INCHES PART MUST BE FREE OF BURRS AND SHARP EDGES</p> <p>NOTED: THIS DOCUMENT CONTAINS PROPRIETARY INFORMATION. IT IS THE PROPERTY OF ADVANCED POLY-PACKAGING INC. AND IS TO BE KEPT CONFIDENTIAL. IT IS TO BE REPRODUCED OR TRANSMITTED IN ANY FORM OR BY ANY MEANS, WITHOUT THE WRITTEN CONSENT OF ADVANCED POLY-PACKAGING INC.</p>					
REV		DATE	CHK	BY	DESCRIPTION
A					NEW LOCATION OF US-300I CONTROLLER BOARD
Advanced Poly Packaging Inc. <small>1221 Everett Road • Weymouth, MA 01988 PHONE: 508-752-7200 FAX: 508-752-7201</small>					
TYPE EQUIPMENT		TA-T10110-S14	TA-T10110-S14	TA-T10110-S14	REV. NO.
SCALE		1:4	NAME	DATE	APPROVED
			CHK	7/13/03	DATE
TITLE		MAIN FRAME ASSEMBLY		DRAWING NO.	TA-T10110-S14
				REV.	A

Advanced Poly-Packaging, Inc.

Bill of Materials Top Level Report for 5/23/2006

(see Drawing No. TA-T10250-S14)

Assembly --> TA-T10250-S14 Main Frame Assy, T-1000-S14

Item	Item No.	Description
1	TA-T10001-S14	Air Knife Assy. T-T1000-S14
2	TA-T10002-S14	Upper Roller Assembly
3	TP-T1MC00001S14	Main Side Plates, T-1000-S14
4	TP-T1MC00017	Vulcanized Rubber Roller
5	TP-T1MC00042NB	Face Plate (NBO)
6	TP-T1MC00052	Guide Roller 1.101.A21.000 16.50RL
7	TP-T1MC00054	Cover Support Clamp (4/M)
8	PENDING	Pending Item Number or N/A
9	TP-T1MC00058	Latch Adjuster Block (2/M)
10	TP-T1MC00059	Latch Lock Block (2/M)
11	TP-T1MC00079	Shaft, Cylinder Pivot
12	TP-T1MC00082	Cover Stand-off (2/M)
13	PENDING	Pending Item Number or N/A
14	TP-T1MC00099	Rear Cover Support (2/M)
15	TP-T1MC00056	Shaft, Rear Support
16	TP-T1MC00163-1	Seal Frame Guide Block-LH
17	TP-T1MC00163-2	Seal Frame Guide Block-RH
18	TP-T1MD00010S14	Pneumatics Mtg.Panel Back Plate S14
19	TP-T1ME00302	High Voltage Cable
20	TP-101105	Nut, 10-32 Hex Mach Screw
21	TP-102154	Washer, #10 Med Split Lock
22	TP-103024	Screw, SHCS 10-32 x 1/2
23	TP-103310	Screw, Sock Shldr 5/16 x 1/2x1/4-20
24	TP-106106	Spring Pins, SS 1/4"Dia. x 1-1/4"Lg
25	TP-108099	Compression Spring,Guide Rollers,MW
26	TP-111010	Collars, Spring Closure (Web Guide)
27	TP-111142	Clamp Collar, 2 pc Split 3/4" Bore
28	PENDING	Pending Item Number or N/A
29	PENDING	Pending Item Number or N/A
30	TP-501170	Motor, Vexta Stepper(NBO,S-14)
31	TP-501169-1	5 Phase Driver,US-4000,NBO,S-14,300
32	TP-503185	Belt, T-1000-S14
33	TP-T1MC00161	Pulley,Brake(T-1000)RollerT-1000S14
34	TP-504113	Bearing, 7612 DLG (2/M)
35	TP-T1MC00162S14	Pulley, Motor T-1000-S14 Stepper
36	TP-T1MC00011S14	Pneumatics MtgPanel Overlay T1K-S14
37	TP-215200	Switch, Magnetic(Threaded Bolt&Nut)
38	TP-103137	***USE TP-103003***Screw, SHCS 1/4-
39	TP-102155	Washer, 1/4 Med Split Lock

ITEM APP# NO REQ DRAWING MATERIAL LIST DESCRIPTION

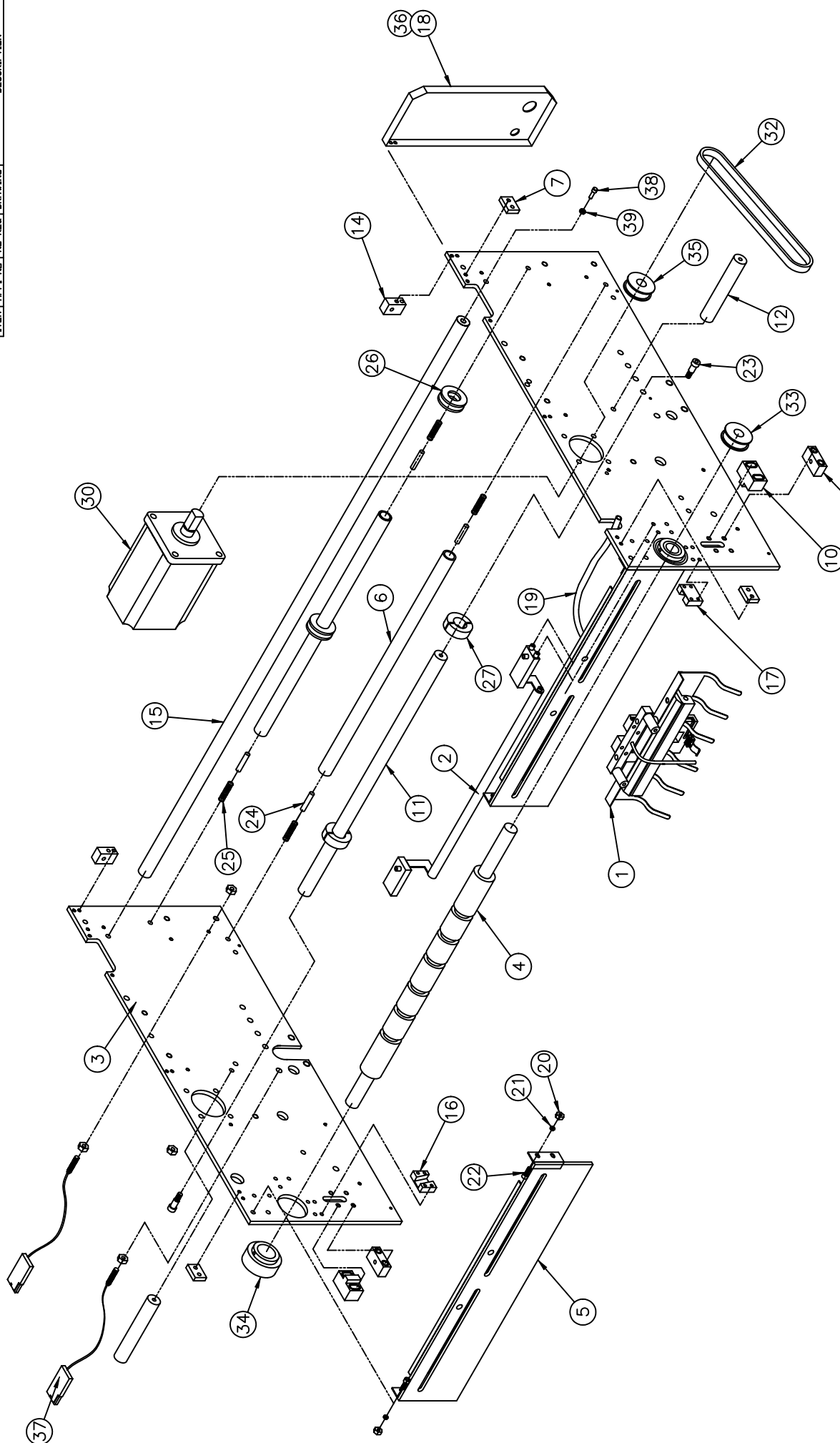

QTY	UNIT	DESCRIPTION
1	EA	MAIN FRAME ASSEMBLY

Advanced Poly Packaging Inc.	
TYPE	TA-T10250-S14
SCALE	1:3
DATE	5/22/2005
REV	A

TELEPHONE: 800-255-5555
 FAX: 800-255-5555
 WWW: WWW.ADVANCEDPOLYPACKAGING.COM

ALL DIMENSIONS ARE IN INCHES
 PART MUST BE FREE OF BURRS AND SHARP EDGES
 METRIC AND SI UNITS CONTAINING UNITS AND DIMENSIONS ARE NOT TO BE USED UNLESS SPECIFICALLY NOTED OTHERWISE IN PART NUMBER OR PART LIST

Advanced Poly-Packaging, Inc.

Bill of Materials Top Level Report for 5/23/2006

(see Drawing No. TA-T10001-S14)

Assembly --> TA-T10001-S14 Air Knife Assy. T-T1000-S14

Item	Item No.	Description
1	PENDING	Pending Item Number or N/A
2	TP-BP-1013-S14	Mounting Bar, Air Knife T-1000-S14
3	TP-BP-1015-S14	Air Nozzle, T-1000-S14
4	PENDING	Pending Item Number or N/A
5	TP-T1MC00020NB	Finger Plate (NBO)
6	TP-405268	Air Knife (Venturi) 6"
7	PENDING	Pending Item Number or N/A
8	TP-T1MC00125S14	Sensor Mounting Bar, T-1000-S14
9	TP-T1MC00083	Insulator, High Volt Sensor
10	TA-T100124-1	High Voltage Sensor
11	TP-T1ME00302	High Voltage Cable
12	TP-103395	Screw, FHCS 8-32 x 5/8
13	PENDING	Pending Item Number or N/A
14	TP-103247	Screw, BHCS 1/4-20 x 7/8
15	TP-101121	Nut, 1/4-20 Jam Hex Pltd
16	TP-102155	Washer, 1/4 Med Split Lock
17	TP-103213	Screw, BHCS 8-32 x 3/4
18	TP-102153	Washer, #8 Med Split Lock
19	PENDING	Pending Item Number or N/A
20	PENDING	Pending Item Number or N/A
21	PENDING	Pending Item Number or N/A
22	TP-401292	Straight, 1/4" Poly x 1/4" NPT
23	TP-401277	Elbow, 1/4" Tube x 10/32 Thread
24	TP-406181	Filter, 4 Micron (Air Knife)
25	TP-401262	Union, Straight 1/4" Tube
26	TP-103390	Screw, FHCS 1/4-20 x 2
27	TP-103196	Screw, BHCS 6-32 x 5/8
28	TP-102152	Washer, #6 Med Split Lock
29	TP-102132	Washer, #6 SAE Flat
30	TP-103196	Screw, BHCS 6-32 x 5/8
31	TP-102102	Lockwasher, #6 Int Tooth Pltd
32	TP-101140	#6-32 Hex Nylon Insert Locknut
33	TP-101126	Nut, Hex Jam Mach Screw 10-32 SS
34	TP-210233	Clamp On Ferrites
35	TP-102142	Washer, 1/4" SAE Flat

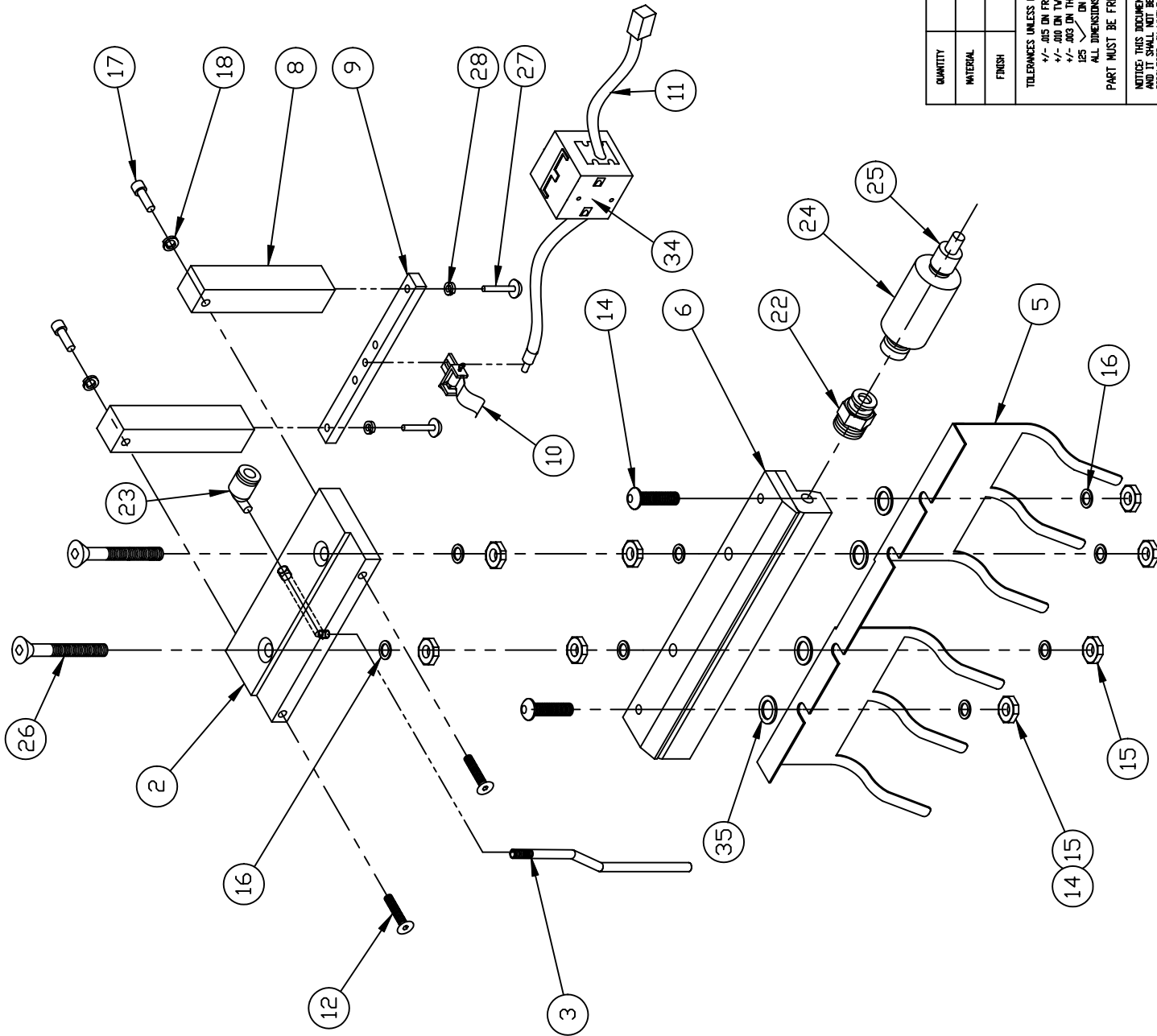

NOTE:

ALL FITTINGS MUST
HAVE TEFLON TAPE

REV	DATE	C.N.K.	BY	DESCRIPTION
A	1/12/06			RE-DESIGNED AIR TUBE & SENSOR MOUNT

		Advanced Poly Packaging Inc. 1331 Everett Road ■ Akron ■ Ohio 44386 Phone: 330-765-4000 ■ Fax: 330-765-4010	
TYPE EQUIPMENT	B/A REF. NO.	PART NO.	
T-T1000-S14			
SCALE	DRAWN BY	APPROVED	
N.T.S.	NAME C.N.K.	NAME	
	DATE 6/8/05	DATE	
TITLE	DRAWING NO.		REV.
AIR KNIFE ASSEMBLY	TA-T10001-S14		A

QUANTITY	MATERIAL	FINISH
TOLERANCES UNLESS OTHERWISE NOTED +/- .010 ON FRACTIONAL DIMENSIONS +/- .005 ON TWO PLACE DECIMAL DIMENSIONS +/- .003 ON THREE PLACE DECIMAL DIMENSIONS ALL DIMENSIONS ARE IN INCHES PART MUST BE FREE OF BURRS AND SHARP EDGES NOTICE: THIS DOCUMENT CONTAINS PROPRIETARY INFORMATION AND IT SHALL NOT BE USED OR REPRODUCED OR ITS CONTENT DISCLOSED IN WHOLE OR IN PART, WITHOUT THE PRIOR WRITTEN CONSENT OF ADVANCED POLY-PACKAGING, INC.		

Advanced Poly-Packaging, Inc.

Bill of Materials Top Level Report for 5/23/2006

(see Drawing No. TA-T10002-S14)

Assembly --> TA-T10002-S14 Upper Roller Assembly

Item	Item No.	Description
1	TP-T1MC00018S14	Roller Mount, T-1000-S14
2	PENDING	Pending Item Number or N/A
3	TP-103130	Screw, SHCS 10-32 x 3/4
4	TP-102154	Washer, #10 Med Split Lock
5	TP-T1MC00118-1	Film Web Roller Bracket (Left)
6	TP-T1MC00118-2	Film Web Roller Bracket (Right)
7	TP-T1MC00119	Film Web Roller
8	TP-T1MC00120	Film Web Roller Shaft
9	PENDING	Pending Item Number or N/A
10	PENDING	Pending Item Number or N/A
11	TP-102152	Washer, #6 Med Split Lock
12	TP-102153	Washer, #8 Med Split Lock
13	TP-102133	Washer, #8 SAE Flat
14	TP-103116	Screw, SHCS 8-32 x 1/2
15	PENDING	Pending Item Number or N/A
16	PENDING	Pending Item Number or N/A
17	PENDING	Pending Item Number or N/A
18	TP-107177	Bushing, 1/4"ID x 3/8"OD x 3/8"Lg
19	PENDING	Pending Item Number or N/A
20	PENDING	Pending Item Number or N/A
21	PENDING	Pending Item Number or N/A
22	PENDING	Pending Item Number or N/A

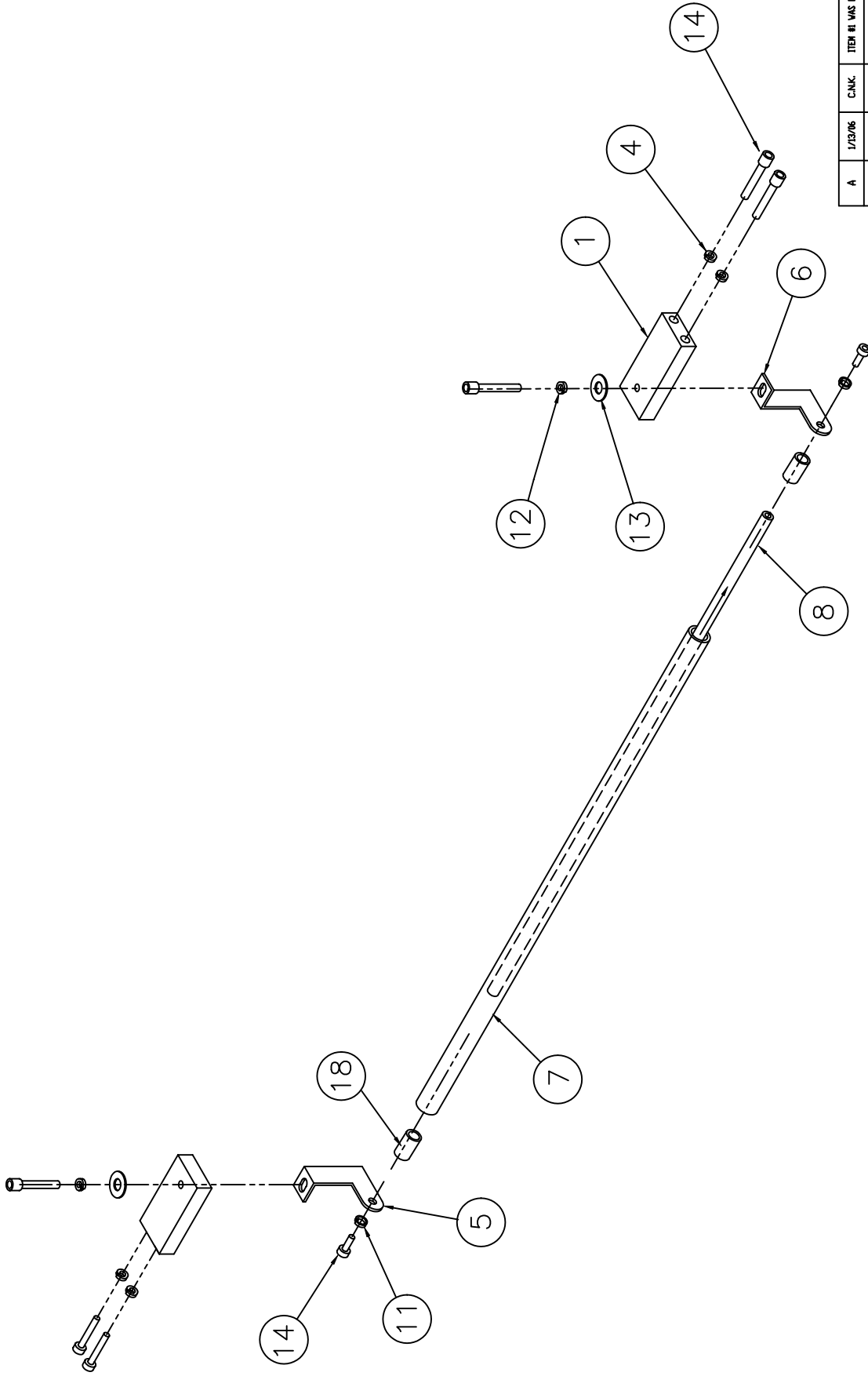

ITEM #	1145	DATE	1/13/06	BY	CAN/C	DESCRIPTION	ITEM #	1145	DATE	1/13/06	BY	CAN/C	DESCRIPTION
REV	A	DATE	1/13/06	BY	CAN/C	DESCRIPTION	REV	A	DATE	1/13/06	BY	CAN/C	DESCRIPTION
<p>Advanced Poly Packaging Inc. 1531 Emmett Road ■ Akron ■ Ohio 44306 Phone: 330-785-4000 ■ Fax: 330-785-4010</p>													
TYPE EQUIPMENT		T-11000-S14		B/M REF. NO.		PART NO.		DRAWN BY		APPROVED		NAME	
SCALE		N.T.S.		DATE		5/12/06		NAME		JLD		DATE	
TITLE		UPPER ROLLER ASSEMBLY		DRAWING NO.		TA-T10002-S14		REV.		B		REV.	

QUANTITY
 MATERIAL
 FINISH

TOLERANCES UNLESS OTHERWISE NOTED
 +/- .005 ON FRACTIONAL DIMENSIONS
 +/- .001 ON TWO PLACE DECIMAL DIMENSIONS
 +/- .0005 ON THREE PLACE DECIMAL DIMENSIONS
 ✓ .125 ON MACHINED SURFACES
 ALL DIMENSIONS ARE IN INCHES
 PART MUST BE FREE OF BURRS AND SHARP EDGES

NOTICE: THIS DOCUMENT CONTAINS PROPRIETARY INFORMATION AND IT SHALL NOT BE USED OR REPRODUCED OR ITS CONTENT DISCLOSED IN WHOLE OR IN PART, WITHOUT THE PRIOR WRITTEN CONSENT OF ADVANCED POLY-PACKAGING INC.

Advanced Poly-Packaging, Inc.

Bill of Materials Top Level Report for 5/23/2006

(see Drawing No. TA-T10270-S14)

Assembly --> TA-T10270-S14 Electrical Panel, T-1000-S14

Item	Item No.	Description
1	TC-T1000-S14	Harness, T-1000-S14 Stepper
2	TP-T1MC00002S14	Angle Mnt-5 Phase Driver T-1000-S14
3	TP-T1MC00016S14	Electronics Mtg. Bracket-T-1000-S14
4	TP-T1MC00006S14	Electronics Mounting Panel Weldment
5	TP-T1MC00008S14	Overlay, Elect. Back Panel T1K-S14
6	TP-T1ME00301	PCB, High Voltage Board Finished
7	TP-207216	Fuse Holder (110v/220v,30Amps)
8	TP-208141	Term.Block,Screw Clamp,15mm AKZ 1.5
9	TP-208410	Terminal Blocks, Direct Mount, PCB
10	TP-211386	Transformer, Dual Voltage
11	TP-208149	Fixed Bridge, 10 Position
12	TP-212166	6 Pin Circular Male Conn (Box Rcpt)
13	TP-212167	6 Pin Circular Fem Conn (Box Rcpt)
14	TP-205108	Filter, RFI Power Line, 10 Amps
15	TP-212242	3 Pin Socket w/Angle Bracket(Fem)
16	TP-212247	9 Pin D-Sub Female (Solder Cup)
17	TP-212248	25 Pin D-sub Female (solder cup)
18	TP-212338	10 Pin Circular Fem Conn (Box Rcpt)
19	TP-212410	Receptacle, Snap-In QC Tabs
20	TP-213266	Cable, Power Supply Cord 12'Long
21	TP-214111	Battery for FP Sigma
22	TP-214268	Standoffs,1/4 4-40 x 3/8",Hex Plast
23	TP-214279	Standoff,Hex 6-32 x 1"
24	TP-215000	Relay, Solid State 10A G-Series
25	TP-215384	Switch, Rocker SPST 250V @ 10A
26	TP-218020	Din-3 Rail,Symmetrical 35mm(1.0M)
27	TP-218021	Rail (1m) Long
28	TP-219455-1	UC-2400 Aux Relay Upgrade(Complete)
29	TP-220508	PLC Analog Module, FPO-A21-A
30	TP-220511	PLC, FPG-C32T2 -Gray
31	TP-220513	PLC, Communication Cassette
32	TP-220514	PLC, FPO-E32T-A Expansion I/O
33	PENDING	Pending Item Number or N/A
34	PENDING	Pending Item Number or N/A
35	TP-501169-1	5 Phase Driver,US-4000,NBO,S-14,300
36	TP-213358	Power Supply,25W 4.00"x2.50"x0.860"
37	PENDING	Pending Item Number or N/A
38	TP-212160	Receptical Plug,5 Position Mini Dip
39	TP-112242	Strain Relief Black 1/2 NPT
40	TP-112243	Locknut, Black, 1/2 NPT
41	TP-104136	Stand Off, Universal (NBO,DC, S-14)

SIDE PLATE

TOP VIEW

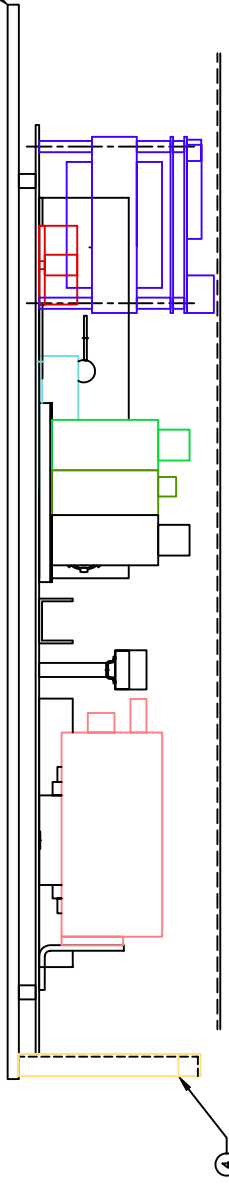

SIDE PLATE

FRONT VIEW

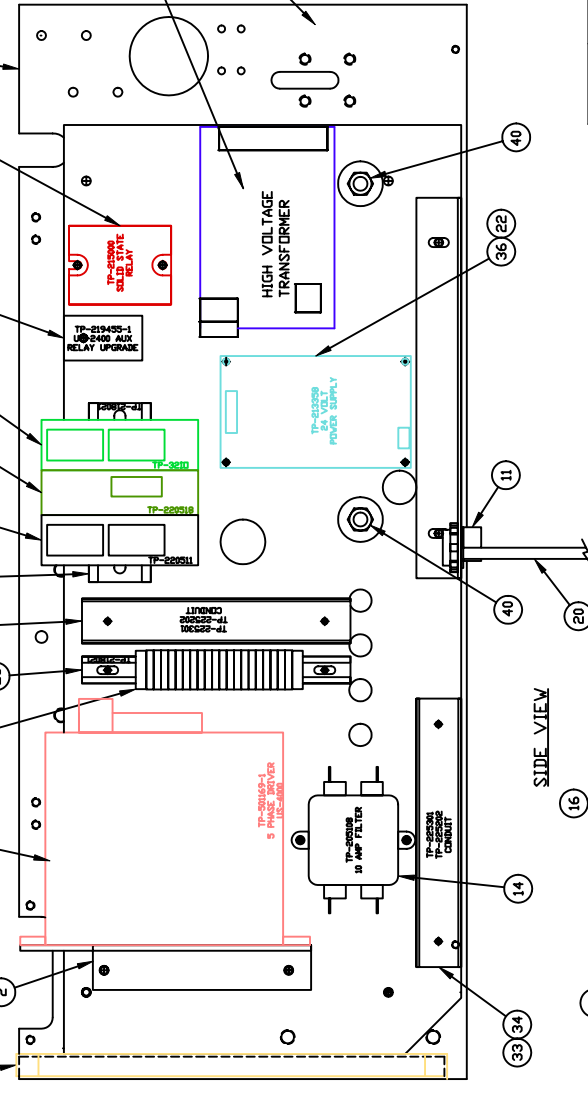

SIDE VIEW

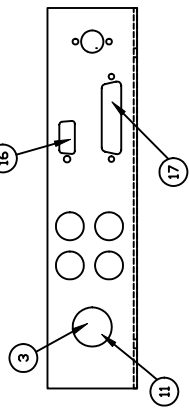

BOTTOM VIEW

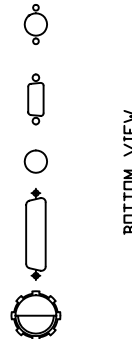

REV	DATE	BY	CNKG	DESCRIPTION
A	1/11/06			ADDED HIGH VOLTAGE TRANSFORMER

Advanced
 Poly Packaging Inc.
 1231 Emmett Road • Akron • Ohio 44306
 Phone: 330-785-5000 • Fax: 330-785-5000

TYPE EQUIPMENT	SCALE	DRAWN BY	CNKG	DATE	APPROVED	DATE
T-1000-S14	1:1			08/25/05		

TOLERANCES UNLESS OTHERWISE NOTED:
 ✓- .010 ON FRACTIONAL DIMENSIONS
 ✓- .005 ON DECIMAL DIMENSIONS
 ✓- .005 ON THREE PLACE DECIMAL DIMENSIONS
 ✓- .010 ON INCH SURFACES
 ✓- .005 ON MACHINED SURFACES
 ALL DIMENSIONS ARE IN INCHES
 PART MUST BE FREE OF BURRS AND SHARP EDGES

NOTICE: THIS DOCUMENT CONTAINS PROPRIETARY INFORMATION AND IT SHALL NOT BE USED OR REPRODUCED OR ITS CONTENT DISCLOSED IN ANY MANNER WITHOUT THE EXPRESS WRITTEN CONSENT OF ADVANCED POLY-PACKAGING, INC.

TITLE	ELECTRICAL PANEL ASSEMBLY	DRAWING NO	REV.
		A-10270-S14	A

Advanced Poly-Packaging, Inc.

Bill of Materials Top Level Report for 5/23/2006 (see Drawing No. TA-T10280-S14)

Assembly --> TA-T10280-S14 Sealer Frame Assy, T-1000-S14

Item	Item No.	Description
1	TA-T10025-S14	Pneumatic Mtg. Valve Assy. S-14
2	TP-403244	Cylinder, NCQ2A4OUIA950549 T-1000
3	TA-T10005	Pressure Bar Sub-Assembly
4	TA-T10006	Heater Bar Sub-Assembly
5	TA-T10009	PTFE Guide Sub-Assembly
6	TA-T10012	Grooved Roller Mounting Sub-Assy
7	TP-403245	Cylinder, 25mm Bore X 10mm Stroke
8	TA-T10017	Bag Finger Grounding Assembly
9	TA-T10019	Latch Sub-Assembly
10	TP-T1MB00005	Gripper Plate (Standard)
11	TP-T1MB00010	Tie Bar, T-1000 Seal Bar
12	TP-T1MB00016	Seal Cylinder Mtg Block
13	TP-T1MB00022	Guard Rod Mounting Block (2/M)
14	TP-T1MB00026	Gripper Plate Spacer
15	TP-T1MB00033	Seal Rod (2/M)
16	TP-T1MB00057	Heater Bar Yoke (2/M)
17	TP-T1MB00062	Latch Handle,L.H.
18	TP-T1MB00063	Latch Shaft
19	TP-T1MB00107	Magnetic Sensor Housing
20	TP-T1MB00144	Shield Mounting Rods (2/M)
21	TP-T1MB00164	Pivot Clamp
22	TP-T1MB00200	Sealer Frame Machined
23	TP-T1ME00209	Seal Bar Coiled Cable Harness
24	TP-101123	Nut, Hex Jam Zinc 3/8-16
25	TP-101132	Nut, Acorn Steel Zinc Pltd 5/16-18
26	TP-101133	Nut, Acorn Zinc Pltd 3/8-16
27	TP-102103	Lockwasher,#8 Int Tooth Pltd Zinc
28	TP-102105	Lockwasher, Int Tooth Pltd 5/16
29	TP-102106	Lockwasher, Int Tooth Pltd 3/8
30	TP-102133	Washer,#8 SAE Flat
31	TP-102143	Washer, SAE Flat 5/16
32	TP-102144	Washer, SAE Flat 3/8"
33	TP-102154	Washer, #10 Med Split Lock
34	TP-102155	Washer,1/4 Med Split Lock
35	TP-102254	Washer, Fender 3/8 x 1-1/2 zinc plt
36	TP-103006-1	Screw, SHCS 3/8-24 x 1
37	TP-103014	Screw, SHCS 10-32 x 1-3/4
38	TP-103116	Screw, SHCS 8-32 x 1/2
39	TP-103129	Screw, SHCS 10-32 x 1/2
40	TP-103003	Screw, SHCS 1/4-20 x 1/2
41	TP-103139	Screw, SHCS 1/4-20 x 3/4
42	TP-103140	Screw, SHCS 1/4-20 x 1
43	TP-103141	Screw, SHCS 1/4-20 x 1-1/4
44	TP-103142	Screw, SHCS 1/4-20 x 1-1/2
45	TP-103186	Screw, Sock Shldr 1/4 x 3/4
46	TP-103210	Screw, BHCS 8-32 x 1/4
47	TP-103225	Screw, BHCS 1/4-20 x 3/4
48	TP-103261	Screw, Set 10-32 x 1/4
49	TP-106109	Spring Pins, SS 1/8 x 3/4
50	TP-106110	Spring Pins, SS 1/8 x 1/2
51	TP-107127-1	Bushing, 12MM ID x 16MM OD x25MM Lg
52	TP-107160	Bushing, 3/8" PTFE Coated
53	TP-107227	Bushing,Thrust Nylon 1/2ID x 1"OD
54	TP-107228	Bushing, Nylon Flange 3/8"IDx1/2"OD
55	TP-211374	Magnet, Round
56	TP-214373	Clamp, 1/4" #10 Screw
57	TP-401254	Union Tee Fitting, 1/4" Tube
58	TP-401257	Elbow, 1/4" Tube x 1/8" NPT
59	TP-401277	Elbow, 1/4" Tube x 10/32 Thread
60	TP-402186	Flow Control (Load Shelf,T1000-S-14

Item	Item No.	Description
61	TP-402105	Flow Control, In Line
62	TP-402106	Holder, Flow Control 1/4"

This page intentionally left blank.

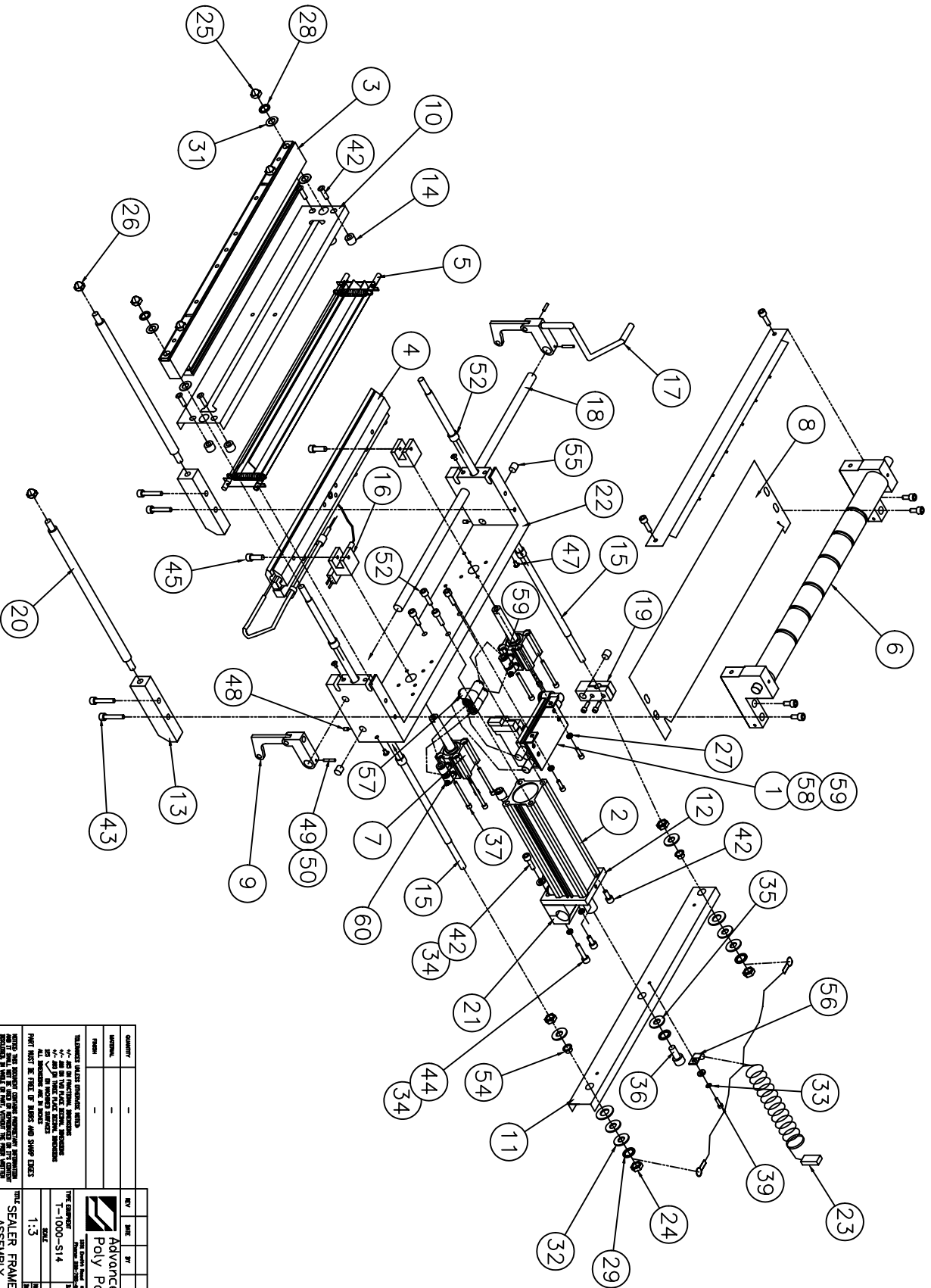

QUANTITY	-	REV	DATE	BY	DESCRIPTION
MATERIAL	-				
<p>TELEPHONE: 848-6966 FAX: 848-6967 11000 S-14 ADVANCED POLY PACKAGING INC. 11000 S-14 1-3 THE SEALER FRAME ASSEMBLY 7A-110280-S14</p>					
<p>ADVANCED POLY PACKAGING INC. 11000 S-14 1-3 THE SEALER FRAME ASSEMBLY 7A-110280-S14</p>					

Advanced Poly-Packaging, Inc.

Bill of Materials Top Level Report for 5/23/2006

(see Drawing No. TA-T10025-S14)

Assembly --> TA-T10025-S14 Pneumatic Mtg. Valve Assy. S-14

Item	Item No.	Description
1	TP-402265	Manifold,D side End Plate
2	TP-402266	Valve, 2 Pos. Single Solenoid
3	TP-402267	Valve, 4 Position, 3 Port NC/NC
4	PENDING	Pending Item Number or N/A
5	TP-402269	D Sub Connector
6	TP-402271	Muffler 8MM O.D.
7	TP-402272	Nipple, Reducer
8	TP-402273	Union, Straight 3/8" O.D.
9	TP-402274	Manifold Block Assembly, Cassette
10	TP-402275	Sup/Exh Block Assembly (s-14)
11	TP-402276	Din Rail (185.5 MM)
12	TP-402277	Pursh, (8 MM O.D.5/15")Plug Connect
13	PENDING	Pending Item Number or N/A
14	PENDING	Pending Item Number or N/A
15	TP-T1MC00015S14	Bracket, Mtg.-Manifold/Flow Control
16	PENDING	Pending Item Number or N/A
17	TP-103129	Screw, SHCS 10-32 x 1/2
18	TP-102154	Washer, #10 Med Split Lock
19	TP-102134	Washer, #10 SAE Flat Zinc
20	TP-101105	Nut, 10-32 Hex Mach Screw
21	TP-103118	Screw, SHCS 8-32 x 1
22	TP-103220	Screw, BHCS 10-32 x 1/2

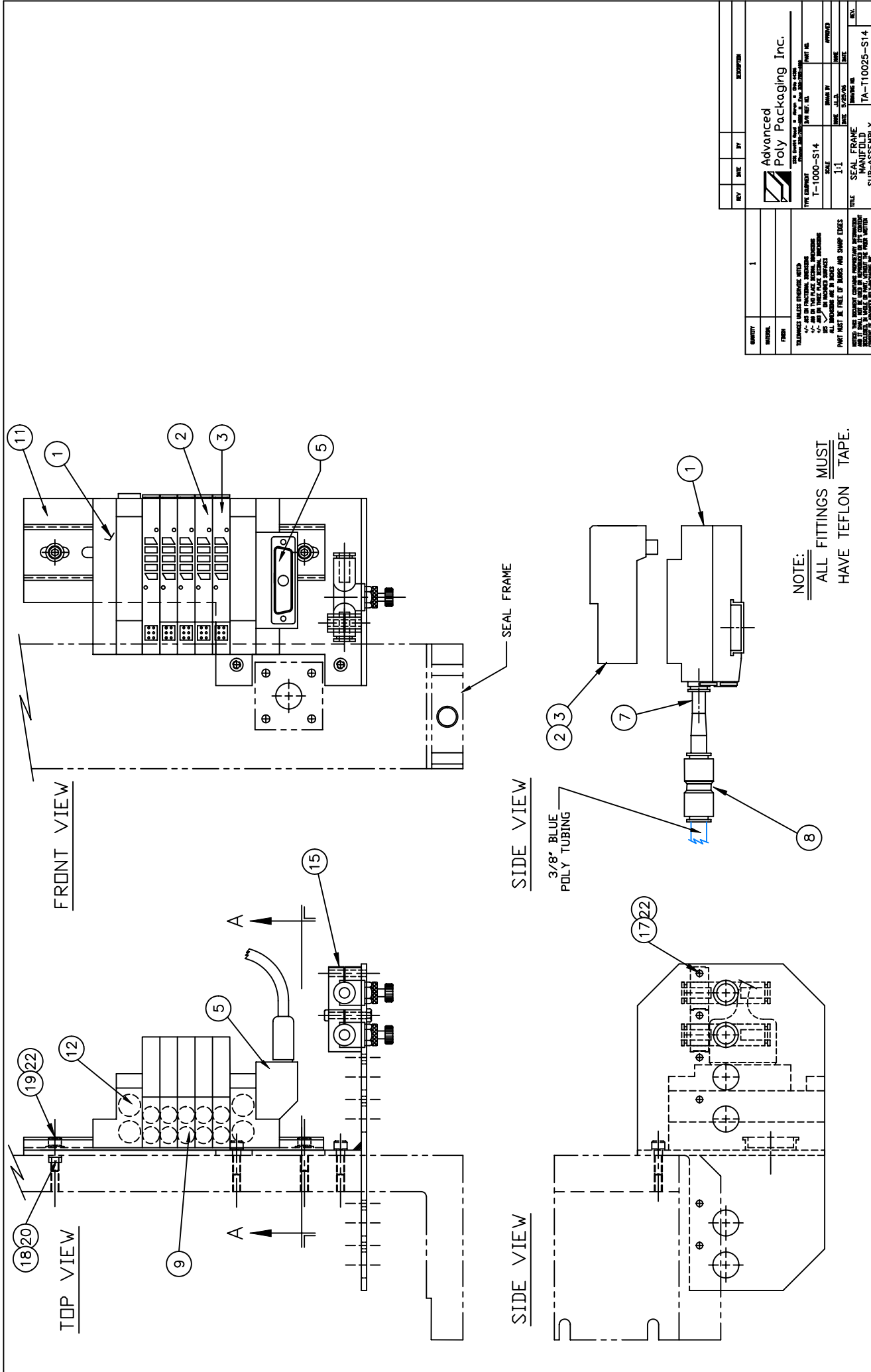

REV	DATE	BY	DESCRIPTION
1			

		Advanced Poly Packaging Inc. 1000 S. 10th St. Waukegan, IL 60087-1000
TITLE	SEAL FRAME MANIFOLD SUB-ASSEMBLY	TA-T10025-S14
DATE	1/1	
SCALE	1:1	
DESIGNED BY	DMH/RYL	
CHECKED BY	DMH/RYL	
APPROVED BY		
DATE	1/1/00	
TIME		
REV.		

QUANTITY 1

UNIT

FORM

TOLERANCES UNLESS OTHERWISE NOTED
 FRACTIONS AS SHOWN
 DIMENSIONS ARE IN INCHES
 UNLESS OTHERWISE NOTED
 ALL DIMENSIONS ARE TO FACE
 UNLESS OTHERWISE NOTED
 PARTS MUST BE FREE OF BURRS AND SHARP EDGES
 AND ALL SURFACES MUST BE FINISHED TO THE SPECIFICATION
 OF THE DRAWING UNLESS OTHERWISE NOTED
 ALL DIMENSIONS ARE TO FACE UNLESS OTHERWISE NOTED
 UNLESS OTHERWISE NOTED

Advanced Poly-Packaging, Inc.

Bill of Materials Top Level Report for 5/23/2006

(see Drawing No. TA-T10005)

Assembly --> TA-T10005

Pressure Bar Sub-Assembly

Item	Item No.	Description
1	TP-T1MB00029	Anti-Jam Pressure Housing
2	TP-T1MB00030	Anti-jam Contact Center Strip
3	TP-T1MB00031	Anti-jam Pressure Pad
4	TP-T1MB00068	Anti-jam Contact Strip (2/M)
5	TP-T1MB00111	Rubber Strip Holder
6	TP-101131	Nut, Acorn Brass Nickel Pltd 1/4-20
7	TP-103139	Screw, SHCS 1/4-20 x 3/4
8	TP-103408	Screw, FHCS 8-32 x 3/8
9	TP-106093	Stud, 1/4-20 x 2.0" (Anti-Jam) Zinc
10	TP-108155	Compression Spring, Pressure Bar
11	TP-306002	Seal Rubber Strip, T-1000-W14
12	TP-300001	Solid Rubber Bumper

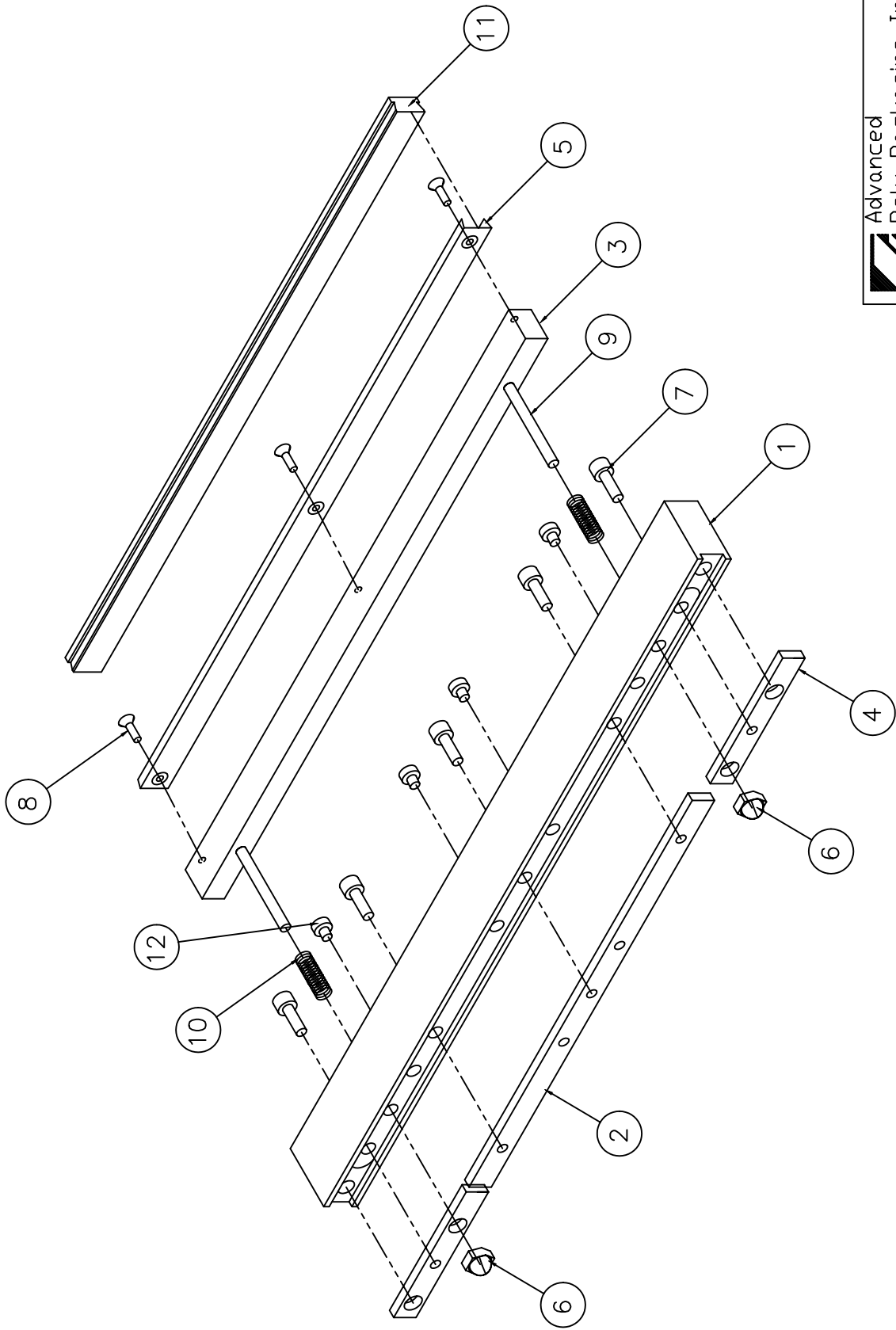

Advanced
Poly Packaging Inc.

1521 Emerald Road • Newark, NJ 07102
 TEL: 908-278-4000 FAX: 908-278-4010
 TYPE EQUIPMENT: T-1000 B/A REF. NO. PART NO.

SCALE	DRAWN BY	APPROVED
N.T.S.	NAME	NAME
	DATE	DATE
	MELODY	7/25/00

TITLE	DRAWING NO.	REV.
PRESSURE BAR	TA-T10005	
SUB-ASSEMBLY		

NOTES: THIS DOCUMENT CONTAINS PROPRIETARY INFORMATION AND IT SHALL NOT BE USED OR REPRODUCED OR ITS CONTENT DISCLOSED, IN WHOLE OR PART, WITHOUT THE PRIOR WRITTEN CONSENT OF ADVANCED POLY-PACKAGING INC.

Advanced Poly-Packaging, Inc.

Bill of Materials Top Level Report for 5/23/2006

(see Drawing No. TA-T10006)

Assembly --> TA-T10006

Heater Bar Sub-Assembly

Item	Item No.	Description
1	TP-T1MB00008	Heater Bar Mtg Plate
2	TP-T1MB00009	Heater Seal Bar
3	TP-T1MB00024	Heater Cartridge Corner Hanger
4	TP-T1MB00145	Thermocouple Wire Tie Down
5	TP-T1MB00159	Heater Cartridge Wire Lead Clamp
6	TP-101126	Nut, Hex Jam Mach Screw 10-32 SS
7	TP-102150	Washer, #10 Flat SS
8	TP-103025	Screw, SHCS 10-32 x 1
9	TP-103242	Screw, BHCS 10-32 x 3/8
10	TP-103248	Screw, BHCS 10-32 x 1
11	TP-104124	Spacer, Round Unthreaded, Alum(HtrBar
12	TP-217116	Cartridge, Heater 800W 120V
13	TP-221416	Thermal-Couple Wire w/ Connector
14	TP-102108	Lockwasher, #10 Int Tooth Pltd
15	TP-102134	Washer, #10 SAE Flat Zinc

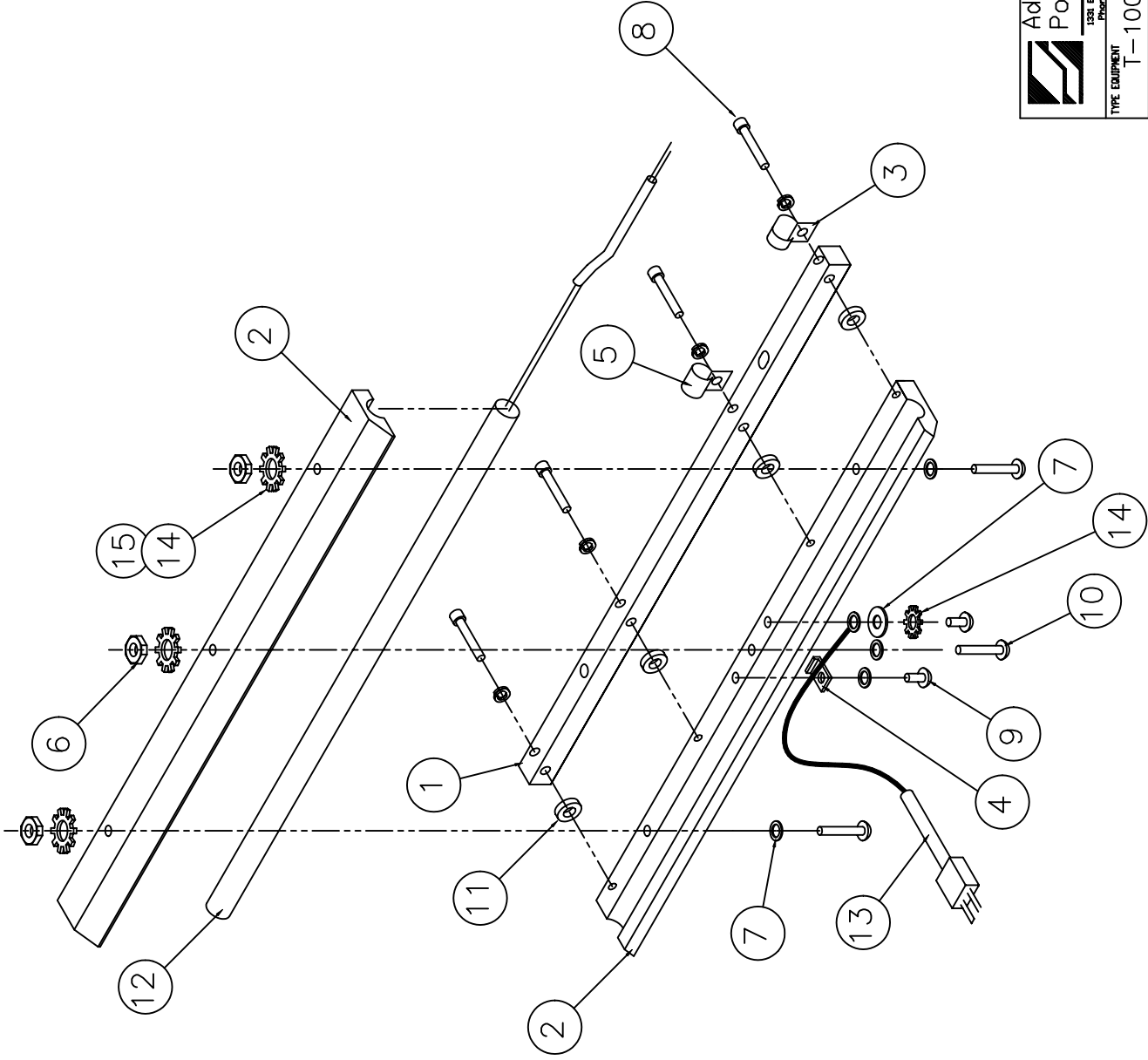

Advanced Poly Packaging Inc.
 1530 Empire Road • Albany • TN 31706
 Phone: 336-258-4000 • Fax: 336-258-4000

TYPE EQUIPMENT	T-1000	DRAWN BY	NAME	MELODY	DATE	APPROVED	
SCALE	N.T.S.				7/26/00		
TITLE	HEATER BAR SUB-ASSEMBLY		DRAWING NO.	TA-T10006		REV.	A

NOTICE: THIS DOCUMENT CONTAINS PROPRIETARY INFORMATION AND IT SHALL NOT BE USED OR REPRODUCED OR ITS CONTENT DISCLOSED, IN WHOLE OR PART, WITHOUT THE PRIOR WRITTEN CONSENT OF ADVANCED POLY-PACKAGING INC.

Advanced Poly-Packaging, Inc.

Bill of Materials Top Level Report for 5/23/2006
(see Drawing No. TA-T10009)

Assembly --> TA-T10009

PTFE Guide Sub-Assembly

Item	Item No.	Description
1	TP-T1MB00034	Bracket Plate Finger (PTFE)
2	TP-T1MB00040	Rod, PTFE (2/M)
3	TP-108156	Extension Spring, PTFE Rod Assy
4	TP-300500	PTFE Sheet (T-1000)

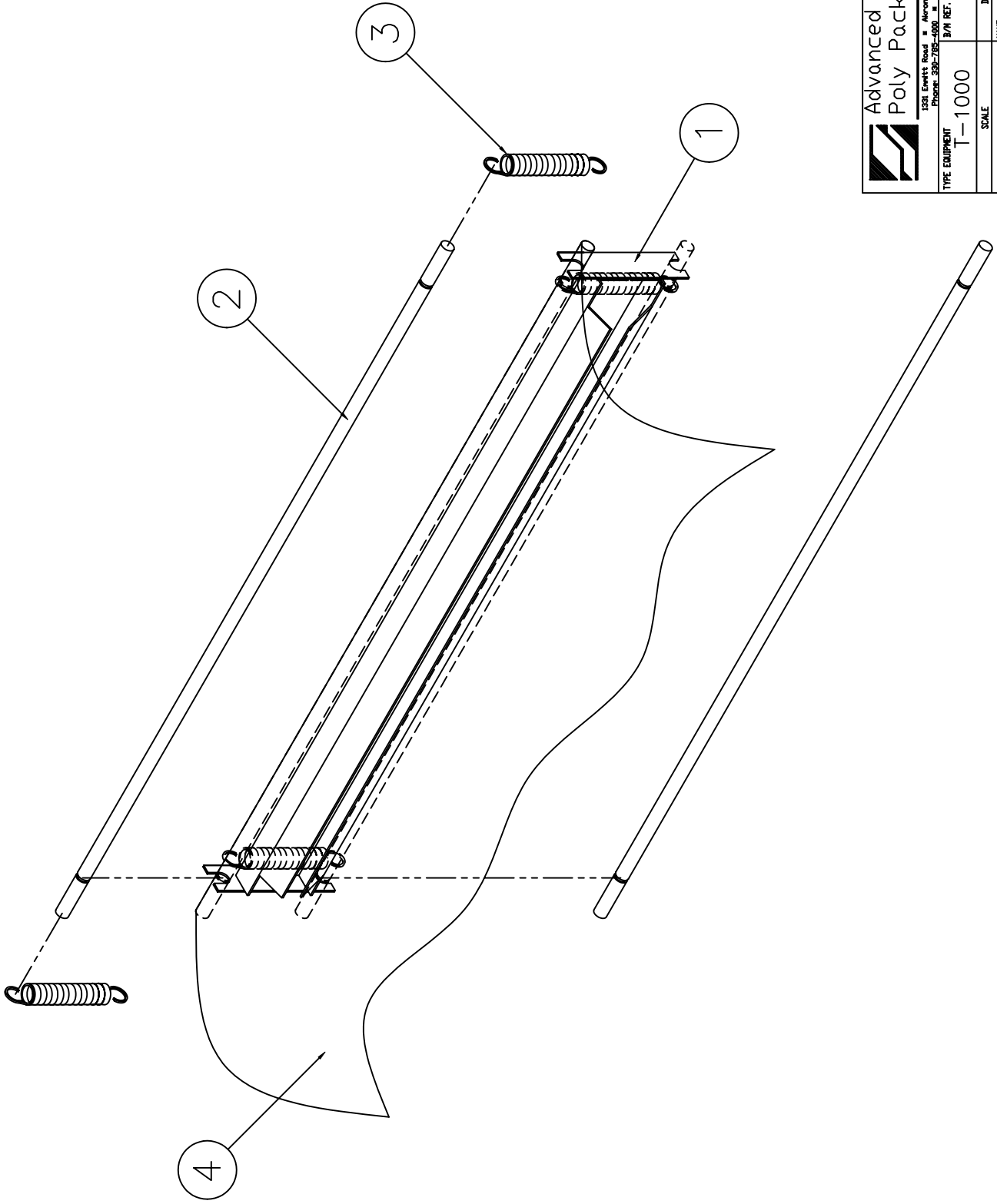

Advanced
Poly Packaging Inc.

1381 Emmett Road ■ Akron ■ Ohio 44306
Phone: 330-795-4000 ■ Fax: 330-795-4010

TYPE EQUIPMENT	T-1000	B/M REF. NO.	PART NO.
SCALE	N.T.S	DRAWN BY	APPROVED
NAME	MELODY	NAME	DATE
DATE	7/19/00	DATE	

TITLE
TEFLON GUIDE
SUB-ASSEMBLY

DRAWING NO.
TA-T10009

REVISIONS

REV.	
------	--

NOTICE: THIS DOCUMENT CONTAINS PROPRIETARY INFORMATION AND IT SHALL NOT BE USED OR REPRODUCED OR ITS CONTENT DISCLOSED, IN WHOLE OR IN PART, WITHOUT THE PRIOR WRITTEN CONSENT OF ADVANCED POLY-PACKAGING INC.

Advanced Poly-Packaging, Inc.

Bill of Materials Top Level Report for 5/23/2006

(see Drawing No. TA-T10012)

Assembly --> TA-T10012

Grooved Roller Mounting Sub-Assy

Item	Item No.	Description
1	TP-T1MB00004	Grooved Metal Roller Mounting Block
2	TP-T1MB00012	Grooved Lower Roller (Steel)
3	TP-T1MB00013	Grooved Lower Roller Shaft
4	TP-T1MB00155	S Frame Film Web Tension Roller
5	TP-T1MB00156	S Frame Film Web Tension Roll Shaft
6	TP-101143	Locknut, Hex Nylon Insert 1/4-20
7	TP-102153	Washer, #8 Med Split Lock
8	TP-103118	Screw, SHCS 8-32 x 1
9	TP-103141	Screw, SHCS 1/4-20 x 1-1/4
10	TP-103249	Screw, SHCS Nylon 1/4-20 x 1
11	TP-103260	Screw, Set 8-32 x 1/4
12	TP-107163	Bushing,Sleeve (Brake Plate-T1000)
13	TP-107227	Bushing,Thrust Nylon 1/2ID x 1"OD
14	TP-504107	Bearing, Nice 1616

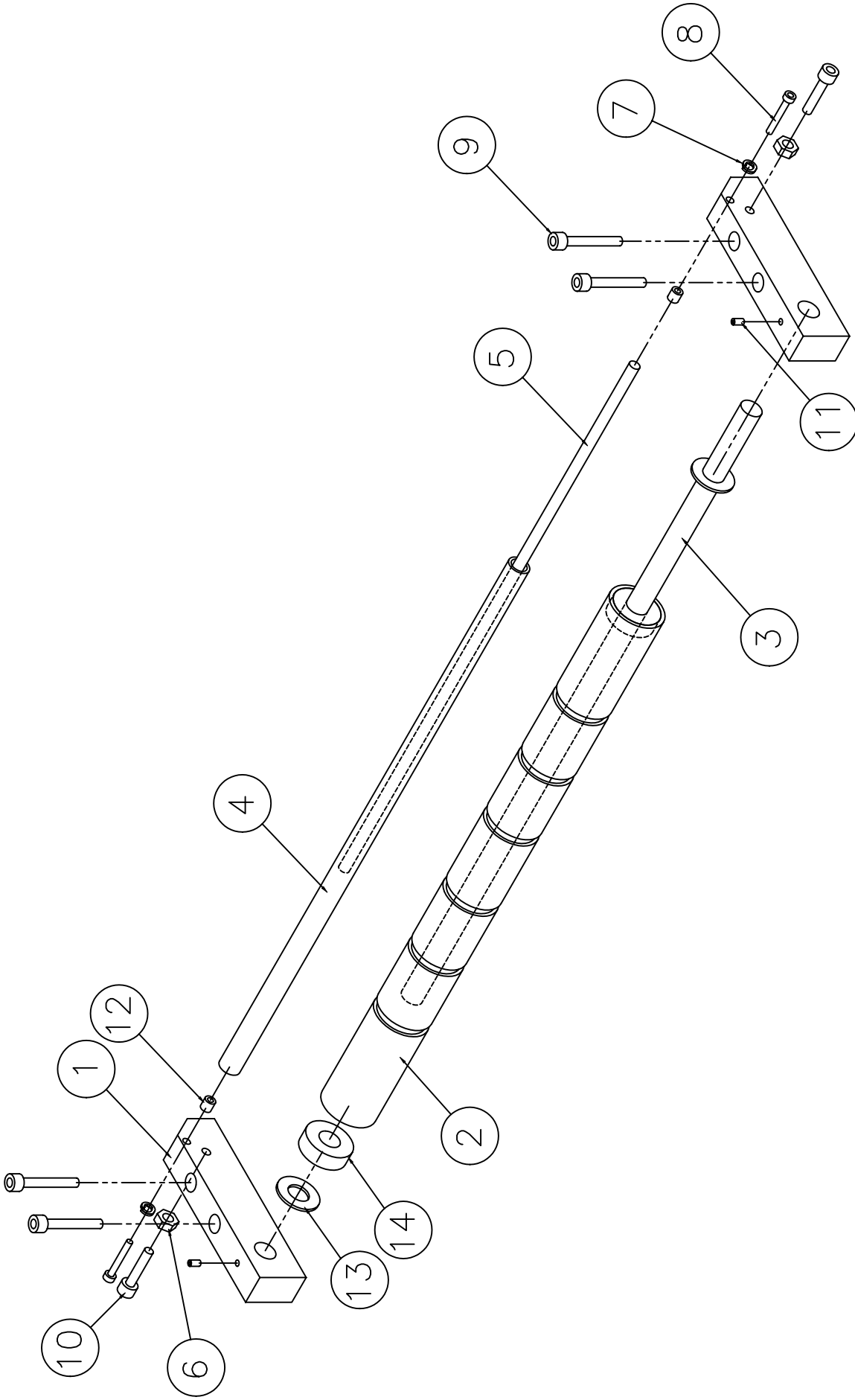

Advanced Poly Packaging Inc.
 1331 Ewett Road • Akron • Ohio 44306
 Phone: 330-785-4000 • Fax: 330-785-4010

TYPE EQUIPMENT	T-1000	B/M REF. NO.	PART NO.
SCALE	N.T.S.	DRAWN BY	APPROVED
		NAME	NAME
		DATE	DATE
		7/25/00	

TITLE	TA-T10012
GROOVED ROLLER MOUNTING SUB-ASSEMBLY	
DRAWING NO.	
REV.	

NOTICE: THIS DOCUMENT CONTAINS PROPRIETARY INFORMATION AND IT SHALL NOT BE USED OR REPRODUCED OR ITS CONTENT DISCLOSED, IN WHOLE OR PART, WITHOUT THE PRIOR WRITTEN CONSENT OF ADVANCED POLY-PACKAGING INC.

Advanced Poly-Packaging, Inc.

Bill of Materials Top Level Report for 5/23/2006

(see Drawing No. TA-T10017)

Assembly --> TA-T10017

Bag Finger Grounding Assembly

Item	Item No.	Description
1	TA-T100124-3	Grounding Sensor
2	TP-T1MB00028	Grooved Metal Roller Finger
3	TP-T1ME00325	Grounding Sensor Wire Assembly
4	TP-101102	Nut,6-32 Hex Mach Screw Pltd
5	TP-102102	Lockwasher,#6 Int Tooth Pltd
6	TP-102132	Washer, #6 SAE Flat
7	TP-103207	Screw, BHCS 6-32 x 3/8

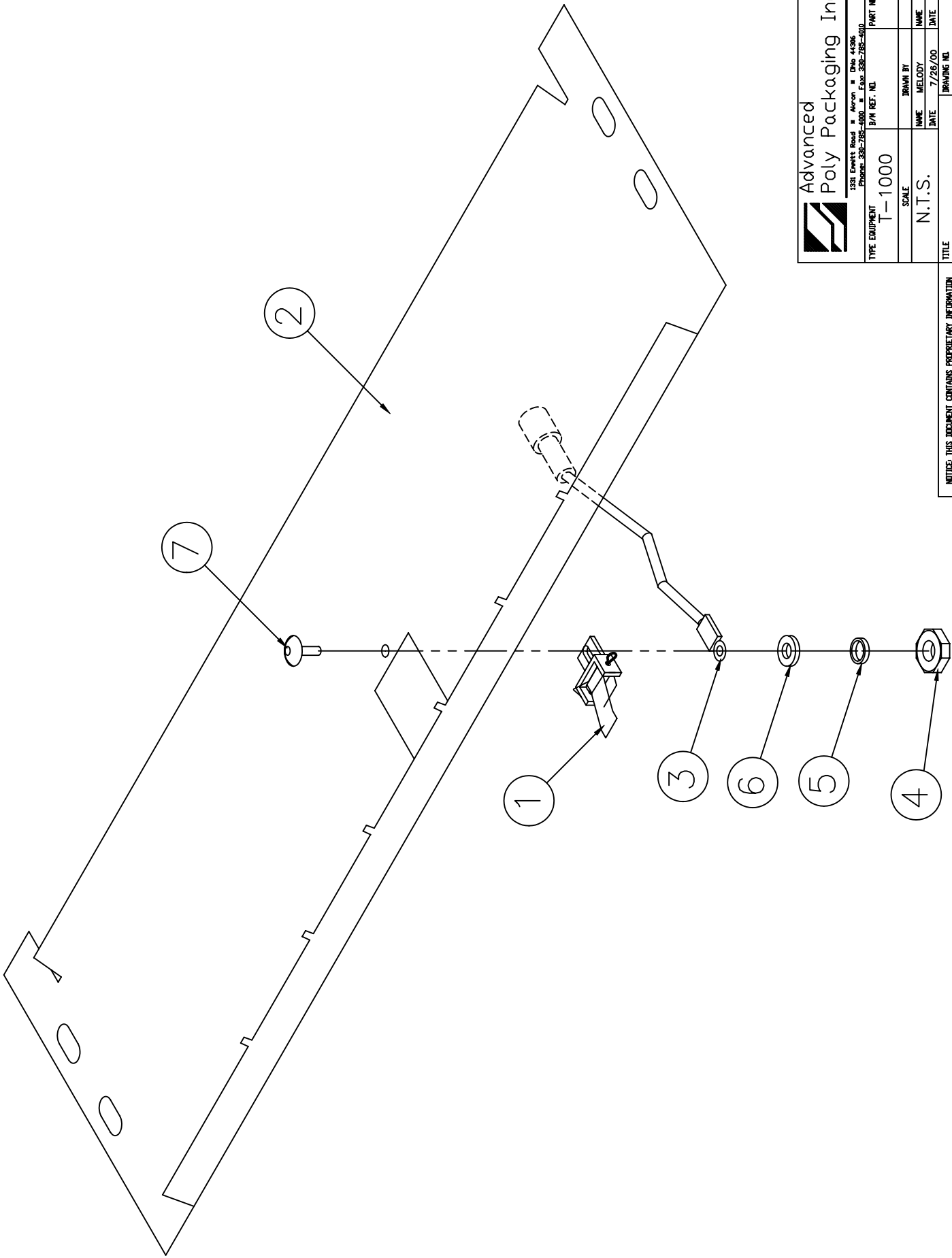

NOTICE: THIS DOCUMENT CONTAINS PROPRIETARY INFORMATION AND IT SHALL NOT BE USED OR REPRODUCED OR ITS CONTENT DISCLOSED, IN WHOLE OR PART, WITHOUT THE PRIOR WRITTEN CONSENT OF ADVANCED POLY-PACKAGING INC.



Advanced Poly Packaging Inc.
 1301 Emmett Road • Alpen • Ohio 44396
 PHONE: 330-252-5600 FAX: 330-252-5600

TYPE EQUIPMENT T-1000	B/P# REF. NO.	DRAWN BY	APPROVED
SCALE N.T.S.		DATE	DATE
		MELODY	7/26/00
		DATE	DATE
TITLE BAG FINGER GROUNDING ASSEMBLY			DRAWING NO. TA-T10017
			REV.

Advanced Poly-Packaging, Inc.

Bill of Materials Top Level Report for 5/23/2006

(see Drawing No. TA-T10019)

Assembly --> TA-T10019

Latch Sub-Assembly

Item	Item No.	Description
1	TP-T1MB00060	Latch Lock (2/M)
2	TP-T1MB00061	Latch Cam (2/M)
3	TP-T1MB00092	Latch Cam Clevis Pin (2/M)
4	TP-106141	Cotter Pin, 1/16 x 3/4 Zinc

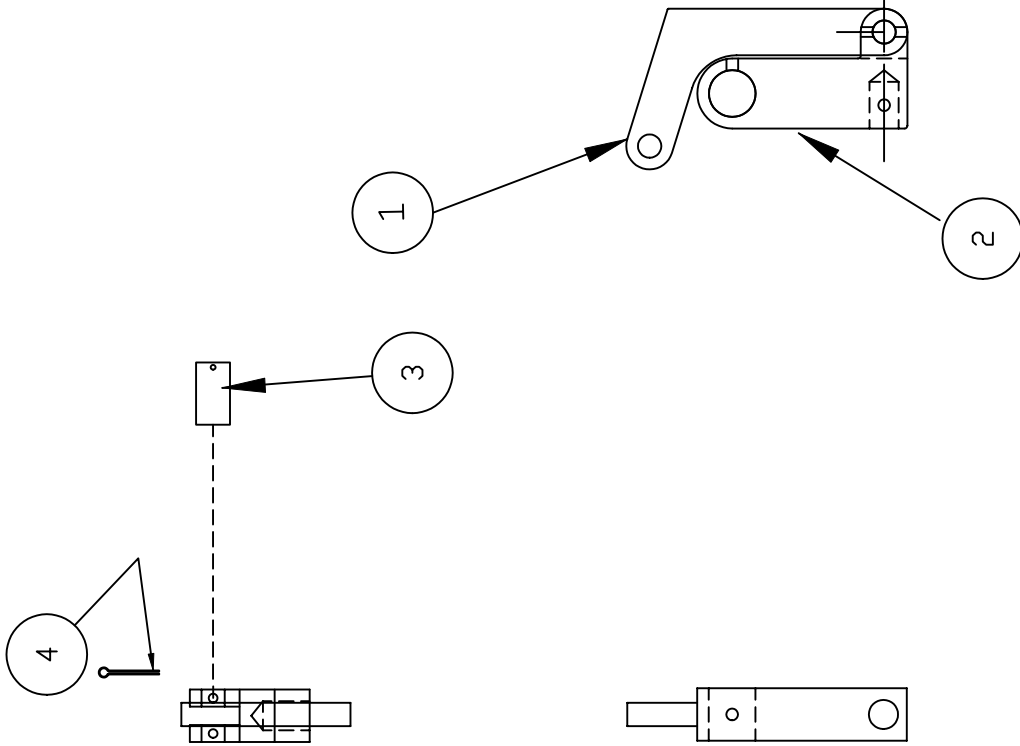

MATERIAL

FINISH

TOLERANCES UNLESS OTHERWISE NOTED:
 +/- .015 ON FRACTIONAL DIMENSIONS
 +/- .010 ON TWO PLACE DECIMAL DIMENSIONS
 +/- .003 ON THREE PLACE DECIMAL DIMENSIONS
 125 ON MACHINED SURFACES
 ALL DIMENSIONS ARE IN INCHES
 PART MUST BE FREE OF BURRS AND SHARP EDGES

NOTICE: THIS DOCUMENT CONTAINS PROPRIETARY INFORMATION AND IT SHALL NOT BE USED OR REPRODUCED FOR ITS CONTENT DISCLOSED IN WHOLE OR PART WITHOUT THE PRIOR WRITTEN CONSENT OF ADVANCED POLY-PACKAGING, INC.

REV	DATE	BY	DESCRIPTION

Advanced Poly Packaging Inc.
 1331 Ewett Road ■ Akron ■ Ohio 44306
 Phone: 330-785-4000 ■ Fax: 330-785-4000

T-1000 BAGGER **B/M REF. NO.** **PART NO.**

SCALE **DRAWN BY** **APPROVED**

FULL **NAME** **M. F. F.** **DATE** **5/28/96** **DATE**

TITLE **DRAWING NO.**

LATCH SUB ASSEMBLY **TA-T10019**

REV. **—**

Advanced Poly-Packaging, Inc.

Bill of Materials Top Level Report for 5/23/2006
(see Drawing No. TA-T10199)

Assembly --> TA-T10199 Stand Assy,T-1000

Item	Item No.	Description
1	TA-T10200	Base Assembly
2	TA-T10210	Upper Column Assy
3	TA-T10220	Dancer Assy

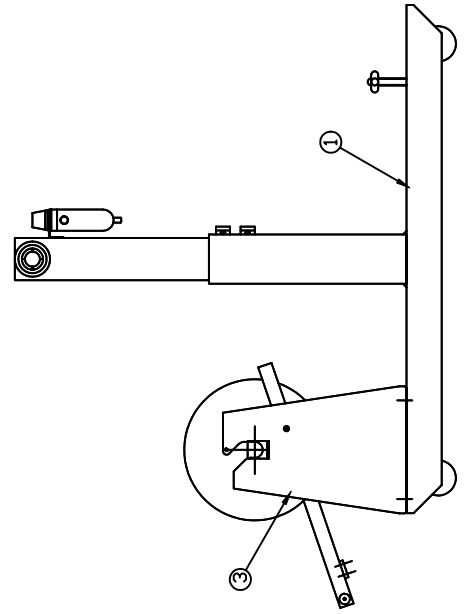
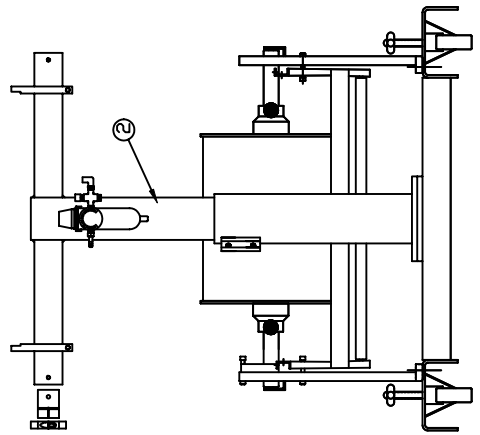
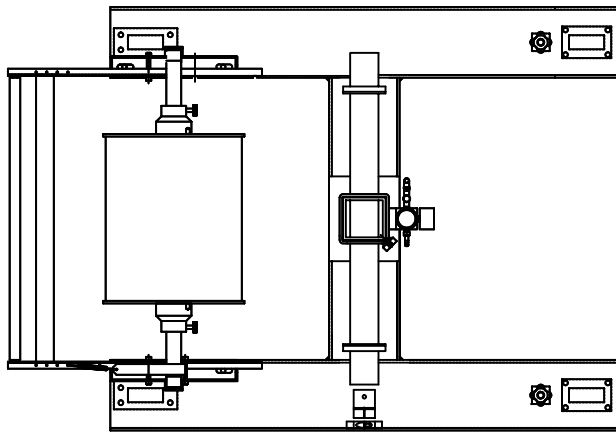

 Advanced Poly Packaging Inc. <small>1000 West 10th Street, Suite 100, Los Angeles, CA 90015</small>		PART NO. _____
TYPE EQUIPMENT T-1000	DRAWN BY _____	APPROVED _____
SCALE N.T.S.	DATE _____	DATE _____
TITLE STAND ASSEMBLY		PART NO. TA-T10199

ALL DIMENSIONS UNLESS OTHERWISE SPECIFIED
 ARE TO BE TAKEN AS SHOWN ON THIS DRAWING
 UNLESS OTHERWISE SPECIFIED BY ADVANCED POLY-PACKAGING INC.

Advanced Poly-Packaging, Inc.

Bill of Materials Top Level Report for 5/23/2006

(see Drawing No. TA-T10200)

Assembly --> TA-T10200

Base Assembly

Item	Item No.	Description
1	TP-T1MA00051	Lower Base Weldment
2	TP-T1MA00051-1	Lower Column
3	TP-T1MA00102	Floor Leveler,Base Assy (2/M)
4	TP-102156	Washer, 5/16 Med Split Lock
5	TP-102157	Washer,3/8 Med Split Lock
6	TP-103541-2	Screw, Socket Set 5/16-18 x 1"
7	TP-103161	Screw, SHCS 5/16-18 x 5/8
8	TP-103150	Screw, SHCS 3/8-16 x 1
9	TP-110756	Swivel Caster 200# Cap.
10	TP-110763	Rigid Caster 200# Cap.

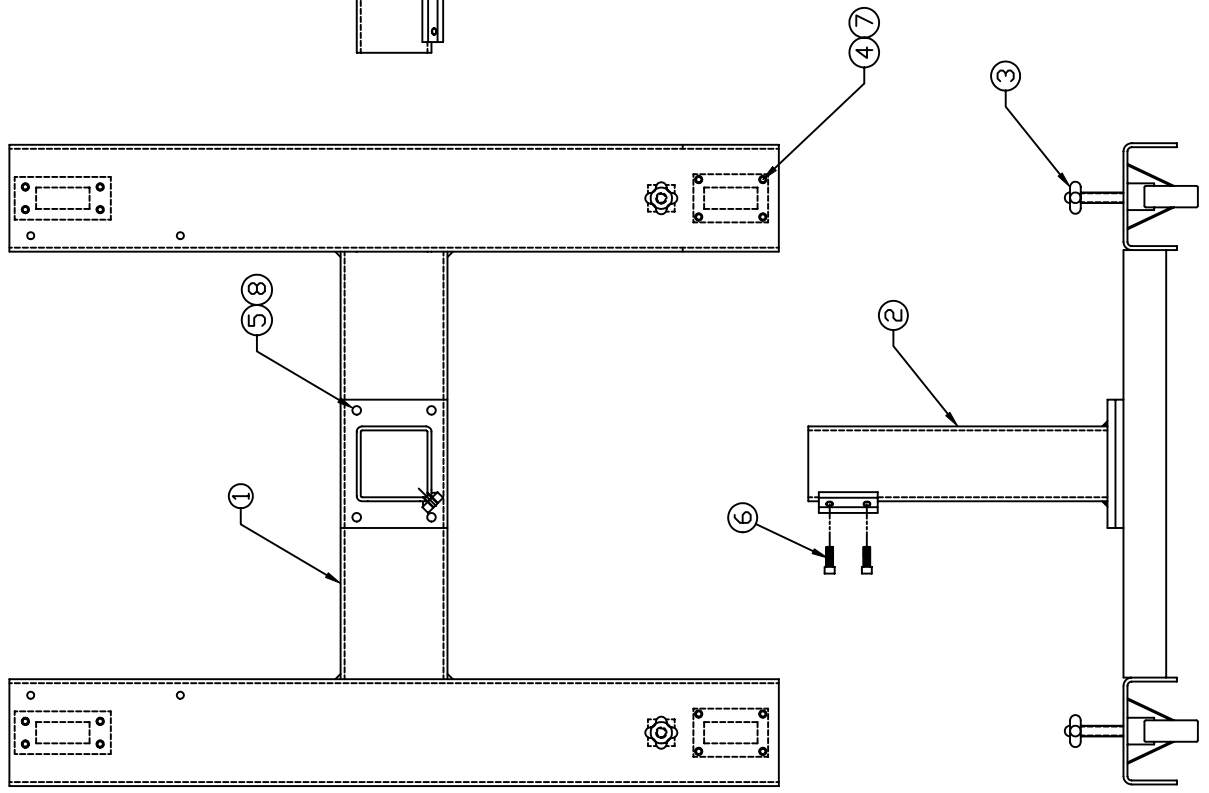
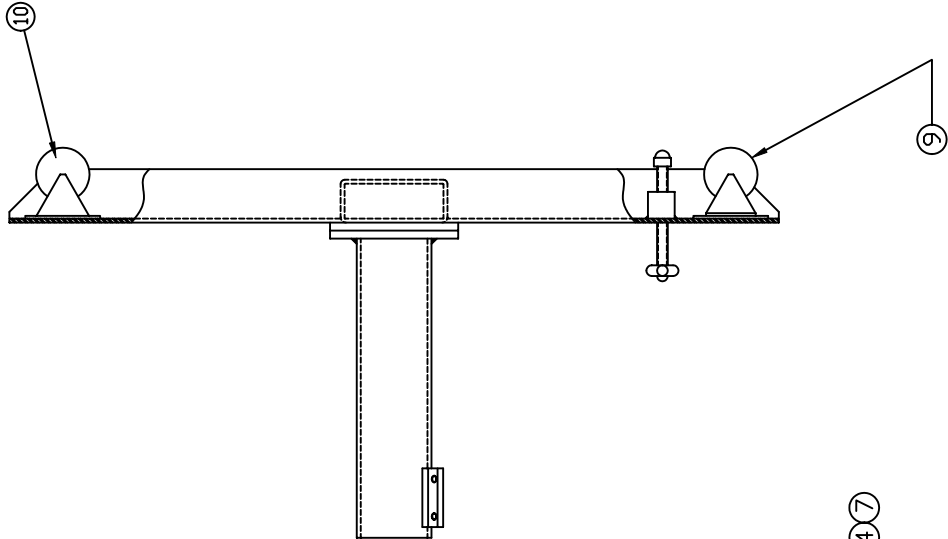

Advanced Poly Packaging Inc. <small>1000 Industrial Blvd. • P.O. Box 1000 • St. Louis, MO 63103</small>	
TYPE COMPONENT	DATE
1-1000	REV. 001
SCALE	APPROVED
N.T.S.	DATE
	BY
	FOR
TITLE BASE ASSEMBLY	
PART NO. TA-T10200	

NOTED: THIS DRAWING CONTAINS INFORMATION WHICH IS UNCLASSIFIED AND IS BEING RELEASED TO THE PUBLIC. ANY REPRODUCTION OF THIS DRAWING IS UNLAWFUL WITHOUT THE WRITTEN PERMISSION OF ADVANCED POLY PACKAGING, INC.

Advanced Poly-Packaging, Inc.

Bill of Materials Top Level Report for 5/23/2006

(see Drawing No. TA-T10210)

Assembly --> TA-T10210

Upper Column Assy

Item	Item No.	Description
1	TP-T1MA00087	Cross Pipe Weldment
2	TP-T1MC00019-1	Base Clamp Block (Left)
3	TP-T1MC00019-2	Base Clamp Block (Right)
4	TP-102134	Washer, #10 SAE Flat Zinc
5	TP-102154	Washer, #10 Med Split Lock
6	TP-102156	Washer, 5/16 Med Split Lock
7	TP-103012	Screw, SHCS 5/16-18 x 2-1/2
8	TP-103127	Screw, SHCS 10-32 x 5/16
9	TP-103136	Screw, SHCS 1/4-20 x 3/8
10	TP-401222	Nipple, 1/4" NPT Quick Connect
11	TP-401224	Nipple, 1/4" Hex
12	TP-401267	Double Universal Elbow 1/4"x3/8"Tube
13	TP-406005	Air Dryer,AD-10
14	TP-406246	Regulator/Filter/Bracket/Gauge Comp

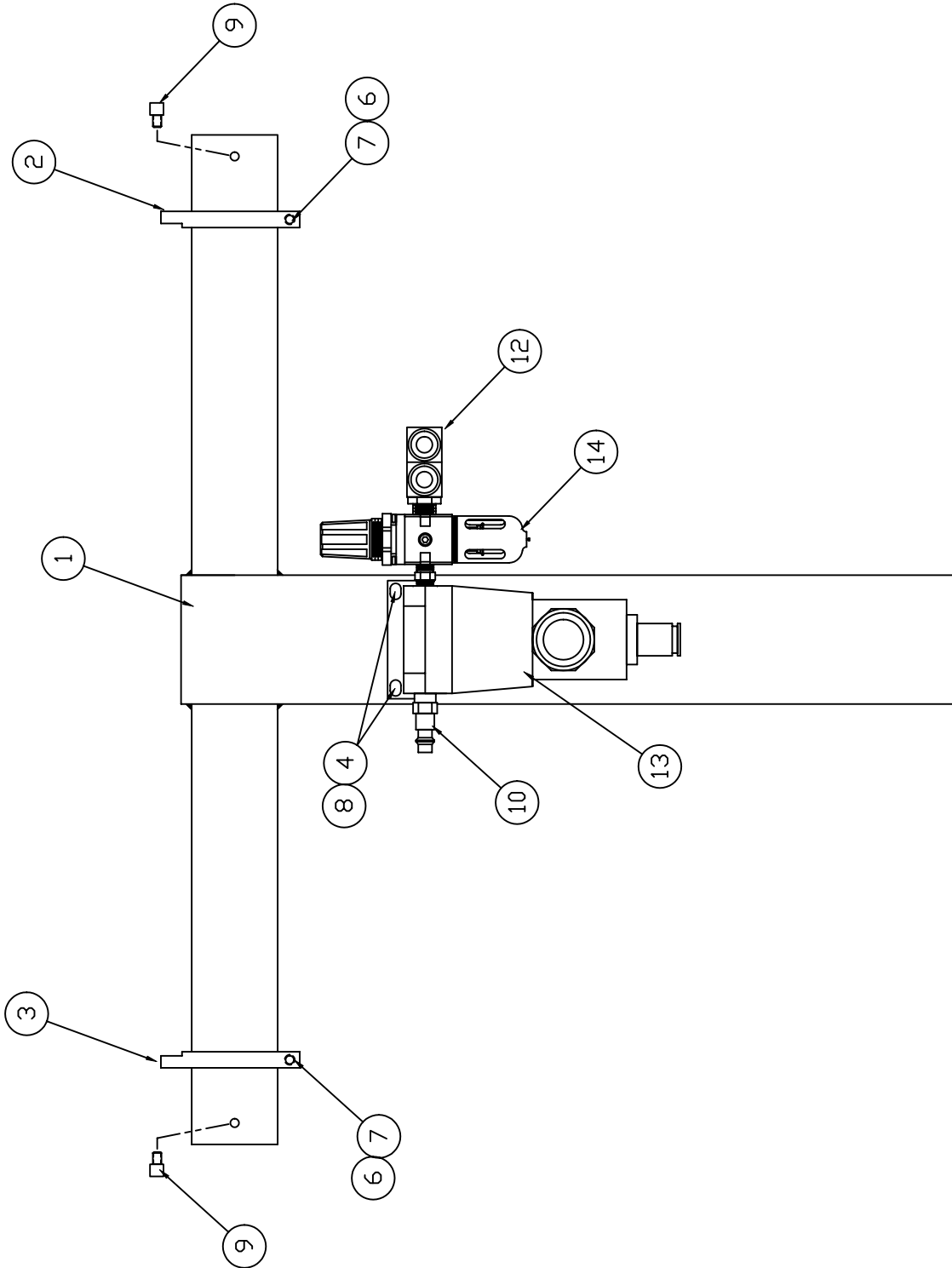

 Advanced Poly Packaging Inc. <small>1521 Ewart Road • Marion • Ohio 43046 Phone: 758-282-8000 • Fax: 758-282-0900</small>		PART NO. TA-T10210
TYPE EQUIPMENT T-1000	B/P REF. NO. N.T.S.	APPROVED NAME MELODY DATE 8/1/00
TITLE UPPER COLUMN ASSEMBLY		DRAWING NO. TA-T10210
NOTICE: THIS DOCUMENT CONTAINS PROPRIETARY INFORMATION THE USE OF WHICH IS LIMITED TO THE CUSTOMER WHOSE BUSINESS IT SERVES. NO PART OF THIS DOCUMENT IS TO BE REPRODUCED OR TRANSMITTED IN ANY FORM OR BY ANY MEANS, ELECTRONIC OR MECHANICAL, WITHOUT THE WRITTEN CONSENT OF ADVANCED POLY-PACKAGING, INC.		REV.

Advanced Poly-Packaging, Inc.

Bill of Materials Top Level Report for 5/23/2006

(see Drawing No. TA-T10220)

Assembly --> TA-T10220

Dancer Assy

Item	Item No.	Description
1	TA-T10010	Film Tension Hub Sub-Assembly
2	TA-T10011	Dancer Guide Sub-Assembly
3	TP-T1MA00069-1	Dancer Side Frame Plate (Left)
4	TP-T1MA00069-2	Dancer Side Frame Plate (Right)
5	TP-T1MA00073	Shaft, Bag Roll (T-1000)
6	TP-T1MA00115	Brake Tension Strap (Dancer)
7	TP-101141	Locknut, Hex Nylon Insert 10-24 Zn
8	TP-102143	Washer, SAE Flat 5/16
9	TP-102156	Washer, 5/16 Med Split Lock
10	TP-103144	Screw, SHCS 5/16-18 x 3/4
11	TP-103237	Screw, BHCS 5/16-18 x 1
12	TP-103307	Screw, Sock Shldr 1/4 x 1-1/4, 10-24
13	TP-504132	Cam Follower

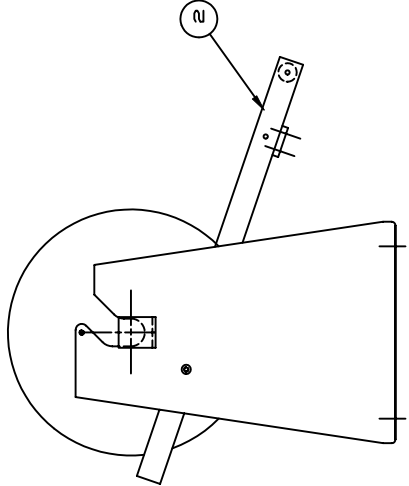
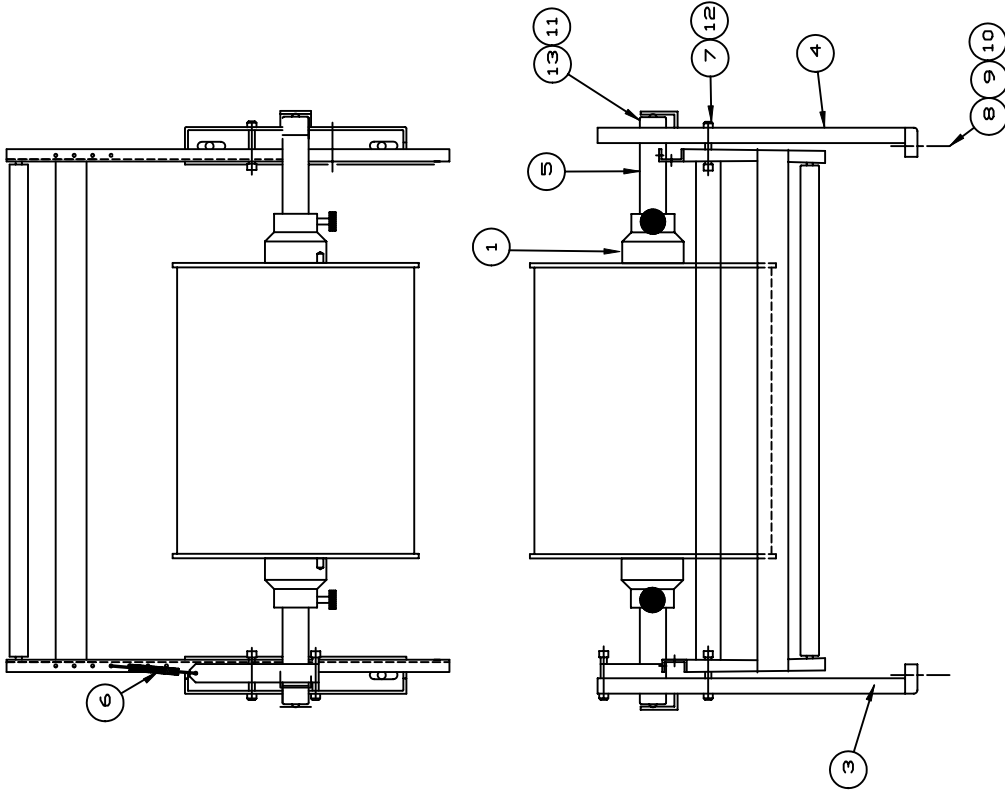

REV	DATE	BY	DESCRIPTION
-	-	-	-
-	-	-	-
-	-	-	-

		Advanced Poly Packaging Inc. 1281 Ewett Road • Akron • Ohio 44306 Phone: 330-282-5887 Fax: 330-282-5888	
TYPE EQUIPMENT	T-1000	DRAWN BY	MELODY
SCALE	1:4	DATE	10/11/01
		APPROVED	
		DATE	10/11/01
		NAME	
TITLE	DANCER ASSEMBLY		
REV.	TA-T10220		
	-		

TOLERANCES UNLESS OTHERWISE NOTED:
 +/- .005 IN FRACTIONAL DIMENSIONS
 +/- .001 IN TWO PLACE DECIMAL DIMENSIONS
 +/- .003 IN THREE PLACE DECIMAL DIMENSIONS
 125 ✓ ON MACHINED SURFACES
 ALL DIMENSIONS ARE IN INCHES
 PART MUST BE FREE OF BURRS AND SHARP EDGES
 NOTICE: THIS DOCUMENT CONTAINS PROPRIETARY INFORMATION AND IT SHALL NOT BE USED OR REPRODUCED OR ITS CONTENT DISCLOSED, IN WHOLE OR IN PART, WITHOUT THE PRIOR WRITTEN CONSENT OF ADVANCED POLY-PACKAGING INC.

Advanced Poly-Packaging, Inc.

Bill of Materials Top Level Report for 5/23/2006

(see Drawing No. TA-T10010)

Assembly --> TA-T10010

Film Tension Hub Sub-Assembly

Item	Item No.	Description
1	TP-T1MA00049	Film Tension Hub (2/Unit)
2	TP-106106	Spring Pins, SS 1/4" Dia. x 1-1/4" Lg
3	TP-109212	Knob, Torque 1/4-20 x 1" Steel Stud

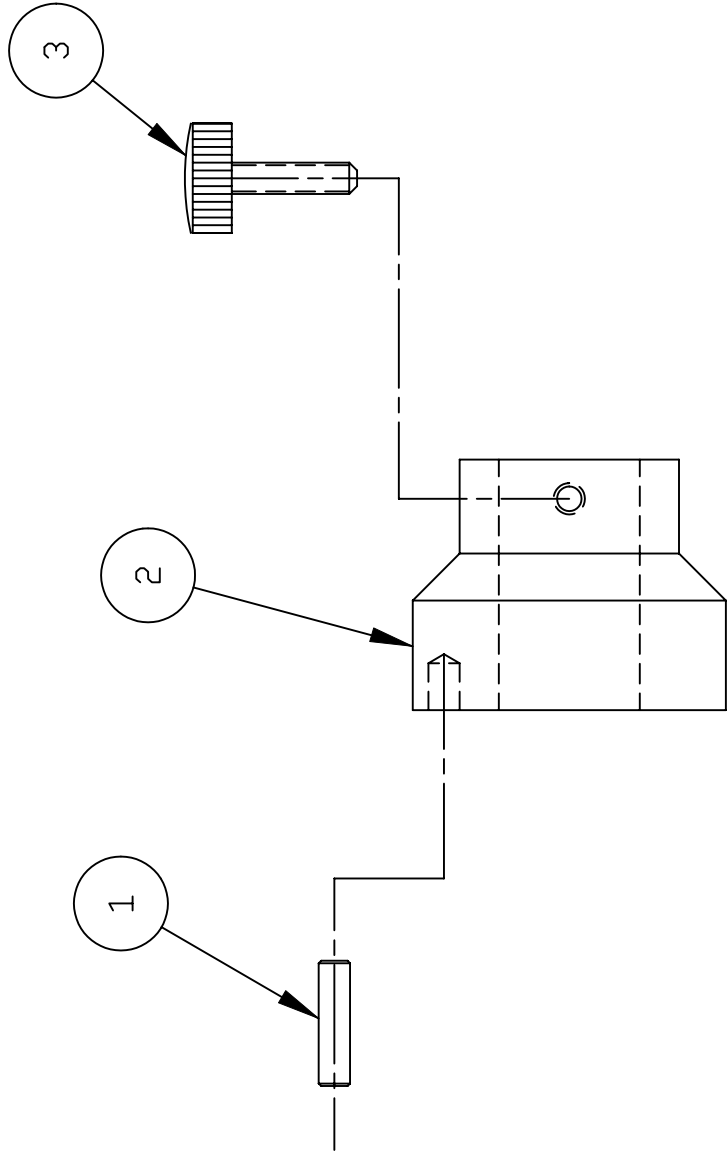

MATERIAL

FINISH

TOLERANCES UNLESS OTHERWISE NOTED:
 +/- .015 ON FRACTIONAL DIMENSIONS
 +/- .010 ON TWO PLACE DECIMAL DIMENSIONS
 +/- .003 ON THREE PLACE DECIMAL DIMENSIONS
 125 ON MACHINED SURFACES
 ALL DIMENSIONS ARE IN INCHES

PART MUST BE FREE OF BURRS AND SHARP EDGES

NOTICE: THIS DOCUMENT CONTAINS PROPRIETARY INFORMATION AND IT SHALL NOT BE USED OR REPRODUCED OR ITS CONTENT DISCLOSED, IN WHOLE OR PART, WITHOUT THE PRIOR WRITTEN CONSENT OF ADVANCED POLY-PACKAGING INC.

Advanced
 Poly Packaging Inc.

1321 Ewitt Road ■ Akron ■ Ohio 44316
 Phone: 330-785-6000 ■ Fax: 330-785-4010

TYPE EQUIPMENT
 T-1000 BAGGER

SCALE
 FULL

1321 Ewitt Road ■ Akron ■ Ohio 44316
 Phone: 330-785-6000 ■ Fax: 330-785-4010

TYPE EQUIPMENT
 T-1000 BAGGER

SCALE
 FULL

1321 Ewitt Road ■ Akron ■ Ohio 44316
 Phone: 330-785-6000 ■ Fax: 330-785-4010

TYPE EQUIPMENT
 T-1000 BAGGER

SCALE
 FULL

1321 Ewitt Road ■ Akron ■ Ohio 44316
 Phone: 330-785-6000 ■ Fax: 330-785-4010

TYPE EQUIPMENT
 T-1000 BAGGER

SCALE
 FULL

1321 Ewitt Road ■ Akron ■ Ohio 44316
 Phone: 330-785-6000 ■ Fax: 330-785-4010

TYPE EQUIPMENT
 T-1000 BAGGER

SCALE
 FULL

1321 Ewitt Road ■ Akron ■ Ohio 44316
 Phone: 330-785-6000 ■ Fax: 330-785-4010

TYPE EQUIPMENT
 T-1000 BAGGER

SCALE
 FULL

1321 Ewitt Road ■ Akron ■ Ohio 44316
 Phone: 330-785-6000 ■ Fax: 330-785-4010

TYPE EQUIPMENT
 T-1000 BAGGER

SCALE
 FULL

1321 Ewitt Road ■ Akron ■ Ohio 44316
 Phone: 330-785-6000 ■ Fax: 330-785-4010

TYPE EQUIPMENT
 T-1000 BAGGER

SCALE
 FULL

1321 Ewitt Road ■ Akron ■ Ohio 44316
 Phone: 330-785-6000 ■ Fax: 330-785-4010

TYPE EQUIPMENT
 T-1000 BAGGER

SCALE
 FULL

1321 Ewitt Road ■ Akron ■ Ohio 44316
 Phone: 330-785-6000 ■ Fax: 330-785-4010

TYPE EQUIPMENT
 T-1000 BAGGER

SCALE
 FULL

1321 Ewitt Road ■ Akron ■ Ohio 44316
 Phone: 330-785-6000 ■ Fax: 330-785-4010

TYPE EQUIPMENT
 T-1000 BAGGER

SCALE
 FULL

1321 Ewitt Road ■ Akron ■ Ohio 44316
 Phone: 330-785-6000 ■ Fax: 330-785-4010

TYPE EQUIPMENT
 T-1000 BAGGER

SCALE
 FULL

Advanced Poly-Packaging, Inc.

Bill of Materials Top Level Report for 5/23/2006

(see Drawing No. TA-T10011)

Assembly --> TA-T10011

Dancer Guide Sub-Assembly

Item	Item No.	Description
1	TP-T1MA00072	Dancer Tension Bar
2	TP-T1MA00081	Dancer Tension Bar Cross Brace
3	TP-T1MA00089	Dancer Roller 1.101.A21.000 20.25RL
4	TP-T1MA00090	Dancer Guide Roller Shaft
5	TP-T1MA00186	Tension Adjuster & Spacer
6	TP-101144	Nut, Hex Mach Screw SS 10-32
7	TP-102153	Washer, #8 Med Split Lock
8	TP-102154	Washer, #10 Med Split Lock
9	TP-102155	Washer, 1/4 Med Split Lock
10	TP-103116	Screw, SHCS 8-32 x 1/2
11	TP-103170	Screw, SHCS 10-32 x 5/8
12	TP-109212	Knob, Torque 1/4-20 x 1"Steel Stud

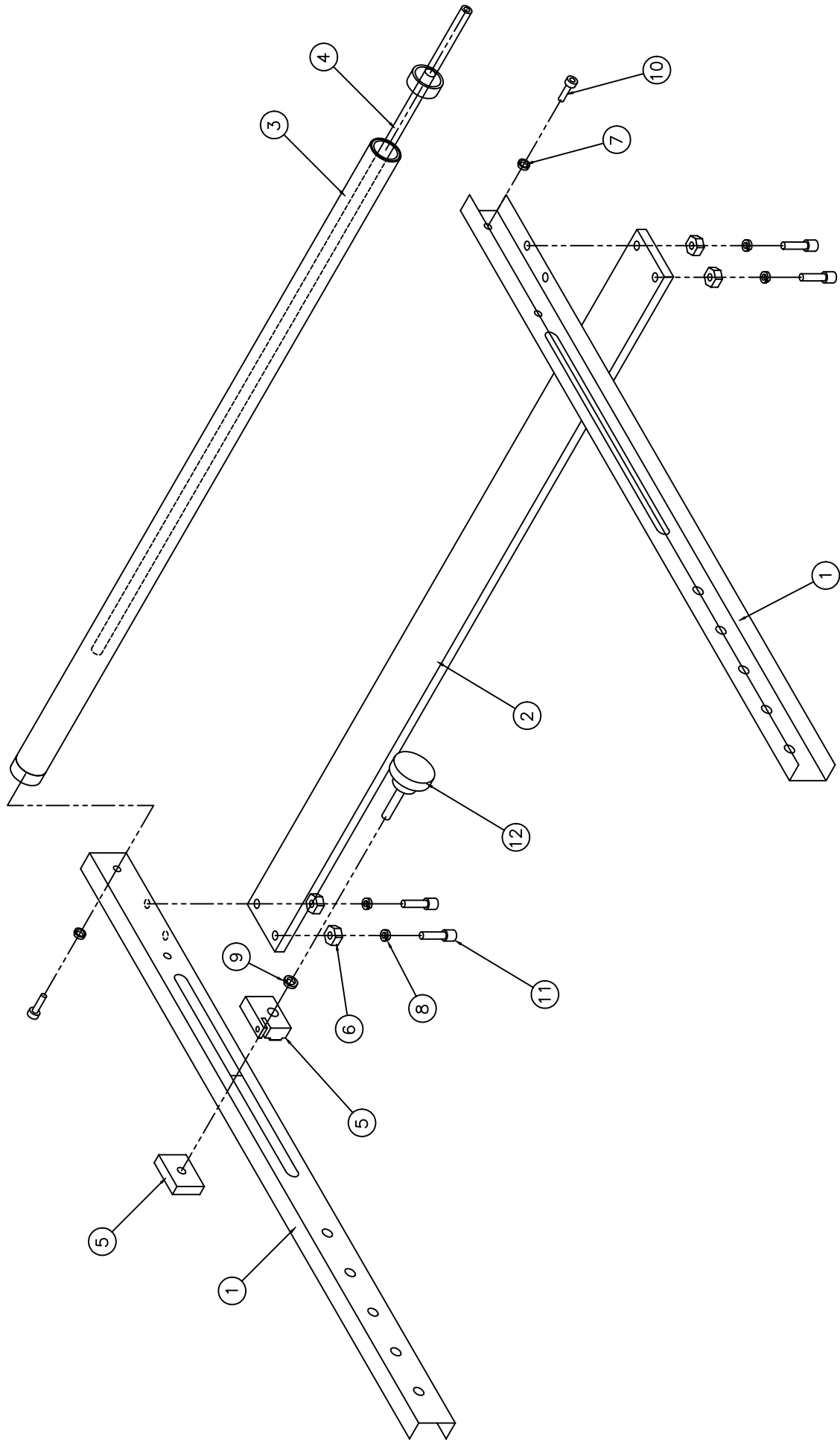

Advanced Poly Packaging Inc.
 520 Emma's Road • Norco • Dist. 44306
 Phone: 337-285-4000 • Fax: 337-285-4000

TITLE	DANCER GUIDE SUB-ASSEMBLY
REV.	A
DRAWING NO.	TA-T10011
DATE	7/19/00
NAME	MELODY
DATE	7/19/00
NAME	N.T.S.
SCALE	N.T.S.
TYPE EQUIPMENT	T-1000
B/M REF. NO.	
PART NO.	
APPROVED	
NAME	
DATE	

NOTICE: THIS DOCUMENT CONTAINS PROPRIETARY INFORMATION AND IT SHALL NOT BE USED OR REPRODUCED OR ITS CONTENT DISCLOSED, IN WHOLE OR PART, WITHOUT THE PRIOR WRITTEN CONSENT OF ADVANCED POLY-PACKAGING INC.

REV	DATE	BY	MELODY	ADDED THE TENSION ADJUSTER AND SLOT ON THE DANCER BAR	DESCRIPTION
A	10/26/00				

Advanced Poly-Packaging, Inc.

Bill of Materials Top Level Report for 5/24/2006

(see Drawing No. TA-T10240-S14)

Assembly --> TA-T10240-S14 Touch Screen Control Assy.T-1000S14

Item	Item No.	Description
1	TP-T1MA00088	Base Clamp Pipe Insert
2	TP-T1MB00196NB	IOP Ctrl.Case Main Frm.Assy S-14
3	PENDING	Pending Item Number or N/A
4	TP-T1MB00197NB	IOP Front Printer Panel T-1000-S14
5	TP-T1MD00094	I.O.P Tube Short
6	TP-T1MD00109	Mounting Bar,Touchscreen
7	TP-102134	Washer, #10 SAE Flat Zinc
8	TP-102154	Washer, #10 Med Split Lock
9	TP-103207	Screw, BHCS 6-32 x 3/8
10	TP-103211	Screw, BHCS 8-32 x 3/8
11	TP-111104	Clamp, Collar 2pc Split 1-1/2"ID
12	TP-111125	Ball Socket Assy, T-1000 (all model
13	TP-111215	Joining Tee,3/4"Pipe,1"Tube,3outlet
14	TP-220348	Touch Screen, 5.7" Disp. (NoPrPt)
15	TC-T1-T2-2	Cable,Printer(IOP/TI-1000)
16	TP-T1MB00198NB	IOP Front Blank Panel Y-1000-S14
17	TP-T1MB00199NB	IOP Front Panel Lexan Overlay S-14
18	PENDING	Pending Item Number or N/A
19	VP-SX40085	Printer LCD Display Board (SX4\SX5)
20	VP-SX40084	LED PC Board Ass'y (SX4\SX5)
21	VP-SX40086	LED-LCD Cable (SX4\SX5)
22	VP-SX40087	LED PC Board Cable (SX4\SX5)
23	TP-T15M3017	Push Button, T-375
24	TP-T14M1064	Board, Mounting Bar Electronic(T375

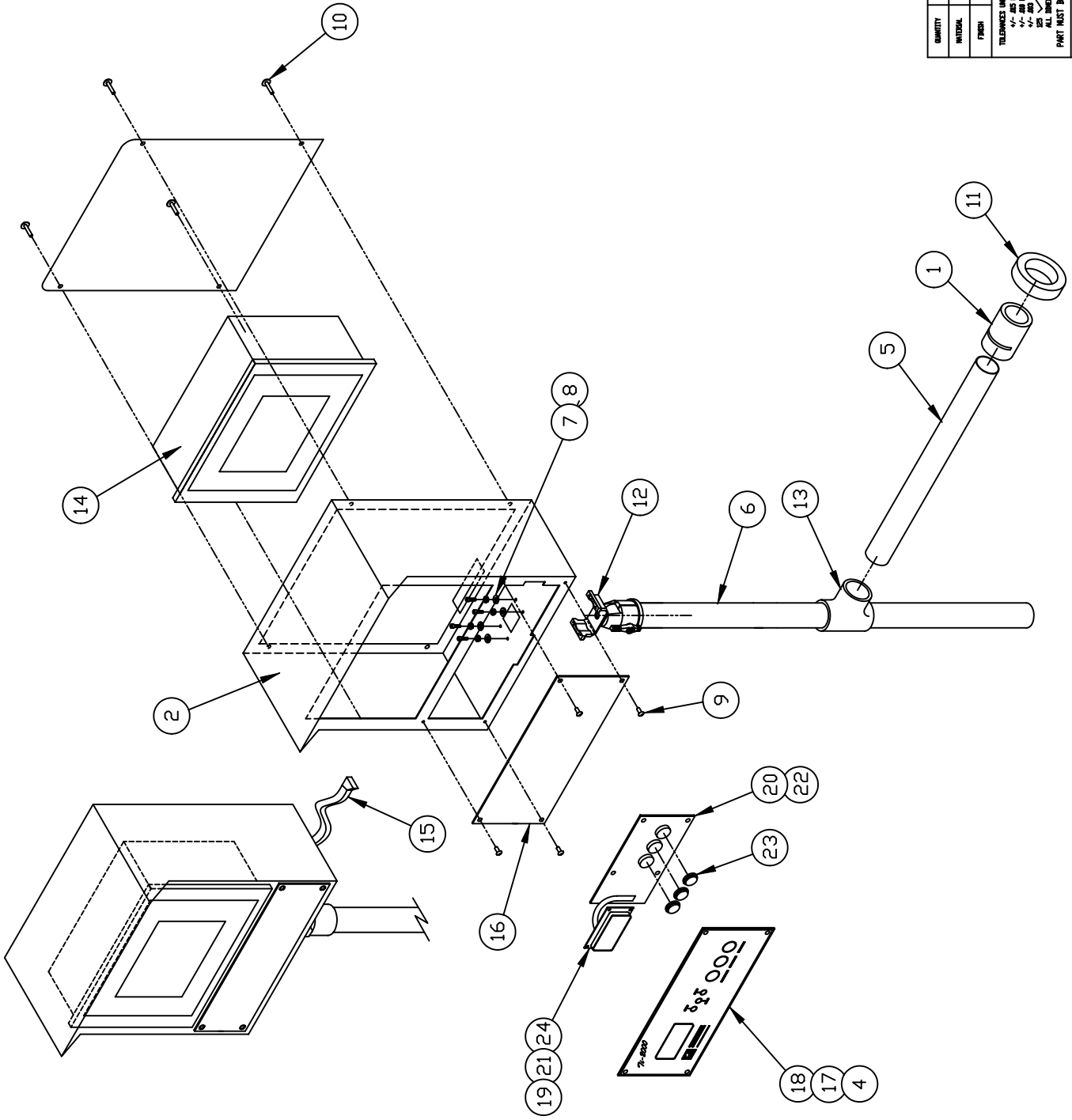

REV	DATE	BY	DESCRIPTION

 Advanced Poly Packaging Inc. <small>1200 Airport Road • Denver, CO 80202 Phone: 303-750-4000 • Fax: 303-750-4000</small>		TYPE EQUIPMENT T-1000-S14	DATE REV. NO. TA-T15-1000 TA-T151000	PART NO. TA-T151000
SCALE NA		DATE CHG. 8/2/05	NAME GSK	APPROVED [Signature]
TITLE IOP ASSEMBLY		DRAWING NO. TA-T10240-S14	REV. [Blank]	

QUANTITY	MATERIAL	REVISIONS

TOLERANCES UNLESS OTHERWISE NOTED:
 +/- .015 ON FRACTIONAL DIMENSIONS
 +/- .005 ON TWO PLACE DECIMAL DIMENSIONS
 +/- .002 ON THREE PLACE DECIMAL DIMENSIONS
 DIMENSIONS ON HATCHED SURFACES
 ALL DIMENSIONS ARE IN INCHES
 PART MUST BE FREE OF BURRS AND SHARP EDGES
 NOTES THIS DRAWING CONTAINS PROPRIETARY INFORMATION
 AND IT SHALL NOT BE REPRODUCED OR ITS CONTENTS
 DISCLOSED TO ANY OTHER PARTY WITHOUT THE
 EXPRESS WRITTEN CONSENT OF ADVANCED POLY PACKAGING INC.

This page intentionally left blank.

Chapter 6, Preventive Maintenance & Scheduled Maintenance

PM Checklist

Schedule Maintenance (CHART)

6.1 Preventative Maintenance & Scheduled Maintenance

To extend the life of the T-1000, qualified maintenance personnel must perform all required maintenance tasks. Failure to perform scheduled and preventative maintenance may cause excessive wear to components and will void the warranty. For the purpose of this manual, preventative maintenance (PM) tasks are considered periodic tasks which should be performed on a daily, weekly or monthly basis.

Scheduled maintenance tasks are performed when the T-1000 Maintenance Chart Number changes to a higher number. Scheduled maintenance tasks (CHART items) are performed dependent upon the number of machine cycles and therefore are not considered "periodic" tasks.

Legend for Preventative Maintenance Checklist

D	Daily
W	Weekly
M	Monthly

6.2 Preventative Maintenance Checklist

ITEM

DESCRIPTION

PERIOD

ITEM	DESCRIPTION	PERIOD
Filter / Air regulator	Drain water from filter	D
Air regulator	Adjust pressure to 80 PSI	D
Antijam device	Check operation, adjust as needed (Chapter 4.10)	D
Pressure bar (rubber)	Clean with alcohol	D
Perforation sensor	Clean sensor assembly with alcohol	W
Upper (rubber) roller	Inspect for nicks or cuts, clean with alcohol	W
Lower (alum.) roller	Clean with alcohol	W
Micron filter / Venturi	Inspect for contamination of filter, replace as needed Inspect for blockage / air restriction	M
Wiring / Connectors	Inspect for loose wiring / connectors, tighten as needed	M
Air lines / Valves / Cylinders	Inspect for loose air lines, listen for leaks, tighten or replace poly tubing as needed	M
Compartments / Covers	Remove all covers, clean and blow out compartments with compressed air to remove dust and dirt	M
Side-plates	Clean and wipe down with lightweight oil (based upon environmental - humidity conditions)	M
Drive belt	Inspect for wear / fraying, replace if needed	M
Drive belt (right panel)	Inspect for looseness, tighten as required	M
Touch Screen cabinet / arms	Tighten set screws	M

Height adjustments screws	Tighten bolts	M
---------------------------	---------------	---

CAUTION: Unplug power cord and disconnect air line prior to removing guards, funnels or covers. Preventative Maintenance must be performed by qualified maintenance personnel.

6.3 Scheduled Maintenance Chart

CHART

ITEM DESCRIPTION 1 2 3 4 5 6 7 8 9

ITEM	DESCRIPTION	1	2	3	4	5	6	7	8	9
Drive belt (right panel)	Adjust/Inspect for wear replace when necessary	O	O	O	O	O	O	O	O	O
Heater element & wiring	Inspect for fraying, cuts, loose connections	O	O	O	O	O	O	O	O	O
Pressure bar assembly	Disassemble, clean, inspect springs for wear, breakage (frequency dependent on environment and product)	O		O		O		O		O
Guide rollers	Inspect for free movement	O	O	O	O	O	O	O	O	O
Roller bearings	Inspect for free movement	O	O	O	O	O	O	O	O	O
Perf sensor & spring	Inspect for wear, replace when necessary		O		O		O		O	
Upper rubber roll	Inspect for cuts, unevenness	O		O	O	O	O	O	O	O
Lower aluminum roller	Clean w/ alcohol, inspect for burs	O	O	O	O	O	O	O	O	O
Printed circuit boards	Blow off with clean, dry air, inspect for loose wires, connectors	O	O	O	O	O	O	O	O	O
Main Seal Cylinder	Listen for air leakage, replace or repair as required	O	O	O	O	O	O	O	O	O
Air (blower) filter	Inspect for contamination, replace as necessary	O	O	O	O	O	O	O	O	O
Air lines & connectors	Inspect for wear, cuts, leaking, replace as required	O	O	O	O	O	O	O	O	O
	INITIALS									

(Note: Each chart change represents 1MM cycles)

Advanced Poly-Packaging, Inc.

Bill of Materials Top Level Report for 5/25/2006
(see Drawing No. TO-T1-SP10-S14)

Assembly --> TO-T1-SP10-S14 SP-10 Spare Parts Kit (T-1000-S14)

Item	Item No.	Description	Qty
1	TA-T100124-1	High Voltage Sensor	1
2	TP-215200	Switch, Magnetic(Threaded Bolt&Nut)	1
3	TP-T1MA00115	Brake Tension Strap (Dancer)	1
4	TP-108155	Compression Spring, Pressure Bar	2
5	TP-111010	Collars, Spring Closure (Web Guide)	4
6	TP-207344	Fuse, 12 Amp, Time Delay	3
7	TP-217116	Cartridge, Heater 800W 120V	1
8	TP-221416	Thermal-Couple Wire w/ Connector	2
9	TP-300500	PTFE Sheet (T-1000)	2
10	TP-306002	Seal Rubber Strip, T-1000-W14	1
11	TP-404266	Poly Tubing,1/4" Dia Blue(33M Roll)	10
12	TP-404267	Poly Tubing,3/8"OD Dia Blue(20M/R1)	5
13	TP-406181	Filter, 4 Micron (Air Knife)	2
14	TP-503185	Belt, T-1000-S14	1
15	TP-101131	Nut, Acorn Brass Nickel Pltd 1/4-20	2

This page intentionally left blank.

Chapter 7

Trouble Shooting

7.1 Trouble Shooting Guide

The items included in this section cover the common causes of trouble which an operator might encounter during the operation of the T-1000. When operating difficulties occur, the best procedure is to observe what is happening; then search out the causes; and effect the correction. Make only one adjustment at a time, checking the results of each adjustment. If an adjustment does not help or escalates the problems, return the settings back to the former position.

CAUTION: These tests and repairs should be performed only by qualified mechanics or electricians and at their own risk.

NOTE: When trouble shooting a T-1000 functioning within a system (e.g.: with conveyors, scales, feeders, counters, etc.), always isolate the equipment and operate each machine individually.

7.2 Troubleshooting Checklist

PROBLEM	POSSIBLE CAUSE	CORRECTIVE ACTION
Touch Screen does not display	<ol style="list-style-type: none"> 1. Power off 2. Loose connection 3. Fuse blown 4. Contrast out of adjustment 	<ol style="list-style-type: none"> 1. Plug in power cord / turn on 2. Tighten connections 3. Replace fuse(s) 4. Adjust screen contrast
No main power light	<ol style="list-style-type: none"> 1. Blown fuse 2. Bulb out 	<ol style="list-style-type: none"> 1. Replace fuse 2. Replace bulb
Pressure bar does not move when foot switch is operated	<ol style="list-style-type: none"> 1. Disconnected air line/foot switch 2. Power off 	<ol style="list-style-type: none"> 1. Hookup air line 2. Turn on power
Pressure bar moves inward but does not reach the front plate (retracts immediately)	<ol style="list-style-type: none"> 1. Anti-jam improperly adjusted 2. Misalignment of guide rods 3. Insufficient air pressure 4. Loose / broken ground wire on guide rods 	<ol style="list-style-type: none"> 1. Adjust anti-jam (section 4.10) 2. Align guide rods (section 4.8) 3. Increase air pressure 4. Connect / tighten ground wires
Pressure bar presses against front plate but does not seal bag	<ol style="list-style-type: none"> 1. Seal time too low 2. Heat (temp.) too low 3. Heater cartridge bad 4. Insufficient air pressure 5. Misalignment of guide rods 6. PTFE folded over 7. Heater bar not extending 8. Seal cylinder bad 9. Heater bar cylinder(s) bad 	<ol style="list-style-type: none"> 1. Increase in bag setup screen 2. Increase in bag setup screen 3. Replace heater cartridge 4. Increase air pressure 5. Align guide rods 6. Turn PTFE 7. Check heater bar cylinders / valve 8. Replace cylinder / valve 9. Replace cylinder / valve

Bag sticks to PTFE or pressure (rubber) bar	<ol style="list-style-type: none"> 1. Seal temp. too high 2. Seal time too high 3. PTFE in poor condition 4. Rubber is dirty / contaminated 	<ol style="list-style-type: none"> 1. Decrease temp in bag setup screen 2. Decrease seal time in bag setup screen 3. Turn / replace PTFE 4. Clean / replace pressure bar rubber
Bag does not tear off completely	<ol style="list-style-type: none"> 1. Bag slipping through rollers 2. Compression pressure insufficient 3. Drive roller not reversing 4. Bag did not index properly 5. Seal rubber dirty / worn 	<ol style="list-style-type: none"> 1. Clean upper and lower rollers with alcohol to remove slip and dirt build-up 2. Adjust roller compression 3. Check tear off cylinder 4. Index another bag for test 5. Clean/ replace rubber
Two bags index from rollers	<ol style="list-style-type: none"> 1. Bag is folded over 2. Perf sensor dirty / damaged 3. Perf sensitivity out of adjustment 4. Ungrounded outlet causing electrical noise 5. Auxiliary equipment - noise 6. Seal point value too high 	<ol style="list-style-type: none"> 1. Lower inner frame and straighten bag 2. Clean / replace perf sensor 3. Contact APPI for perf adj. 4. Plug into "clean" power source 5. Contact APPI for solution 6. Set value lower
Bag does not completely index	<ol style="list-style-type: none"> 1. Perf is sensing hole in bag (vent) 2. Seal position setting too low 	<ol style="list-style-type: none"> 1. Reposition bag 2. Increase seal position in bag setup screen
Bag web indexing to floor level without stopping on bag	<ol style="list-style-type: none"> 1. Perf Sensor not sensing bag 2. Dirty / damaged sensor 3. Perf sensor out of adjustment 	<ol style="list-style-type: none"> 2. Clean / replace sensor 1 & 3. Contact APPI for adjustment
Bags web breaking prematurely in machine	<ol style="list-style-type: none"> 1. Improper web tension 2. Web dragging foreign objects 3. Bag roll side-plates bent inward 	<ol style="list-style-type: none"> 1. Adjust tension 2. Remove obstructions 3. Repair / remove side-plates

7.3 Wiring Tab (Point to Point)

A point to point wiring tab drawing is provided to assist in troubleshooting the T-1000. The drawing provides locations or all connection points and routings of wiring. See Dwg TC-T1000-S14.

7.4 110V Circuit

Circuit drawings are provided to assist in troubleshooting the functionality of the T-1000 and also the interface signaling with auxiliary infeed equipment.

A circuit diagram of the 110V circuit is comprised of main power to the T-1000, through the fuse, Corcom filter, motor controller, solid state relay, heater element, line out, and into the power supply printed circuit board. See Dwg T1kSTNB-E1.

7.5 Analog Card, Temperature Controller, Heater Circuit

A circuit diagram of the Analog controller FPO-A21 with correct Dip switch settings is provided. See Dwg T1kSTNB-E3. With a Thermocouple input (TC), the analog card has built in PID and auto tuning functions with 16 bit resolution for very accurate temperature controls. See Dwg T1kSTNB-E3.

7.6 Stepper Motor Circuit

A circuit diagram of the stepper motor controller is provided with correct Dip switch and Pot settings. See Dwg T1kST-E4.

7.7 Perforation Sensor PCB

APPI manufactures the printed circuit board for accurate and consistent perforation detection, for accurate bag positioning and registration. A circuit diagram is provided for this PCB. See Dwg T1kSTNB-E5.

7.8 Aux Interface

APPI provides for a closed loop signal with auxiliary infeed equipment. The circuit diagram references the pinouts on Aux 2 connector, located on the T-1000 rear electrical panel (military connector). See Dwg T1kST-E7.

7.9 Solenoid Valve Circuit Diagram

The T-1000 is equipped with an expandable Valve manifold, pre wired for up to 7 options solenoid valves. Valve stations 1 through 4 are standard, and valve station 5-11 are options. PLC output information, DB25 pin outs, voltages and valve descriptions are provided on this circuit diagram. See Dwg T1kST-E8.

7.10 Pneumatic Piping Diagram

APPI offers a piping diagram to assist in troubleshooting the T-1000 bagger. Piping from Solenoid Valve Stations 5 through 11 will change based on the configuration of the T-1000 and the options ordered by the customer. See Dwg PL-S14.

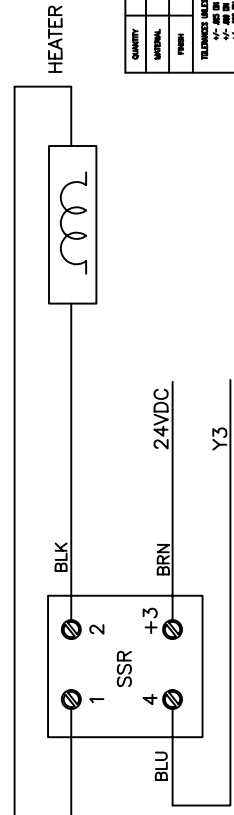
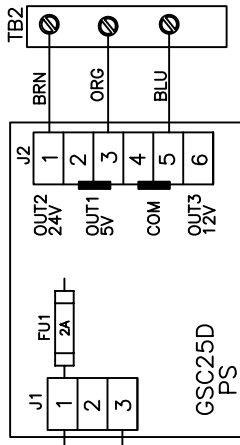
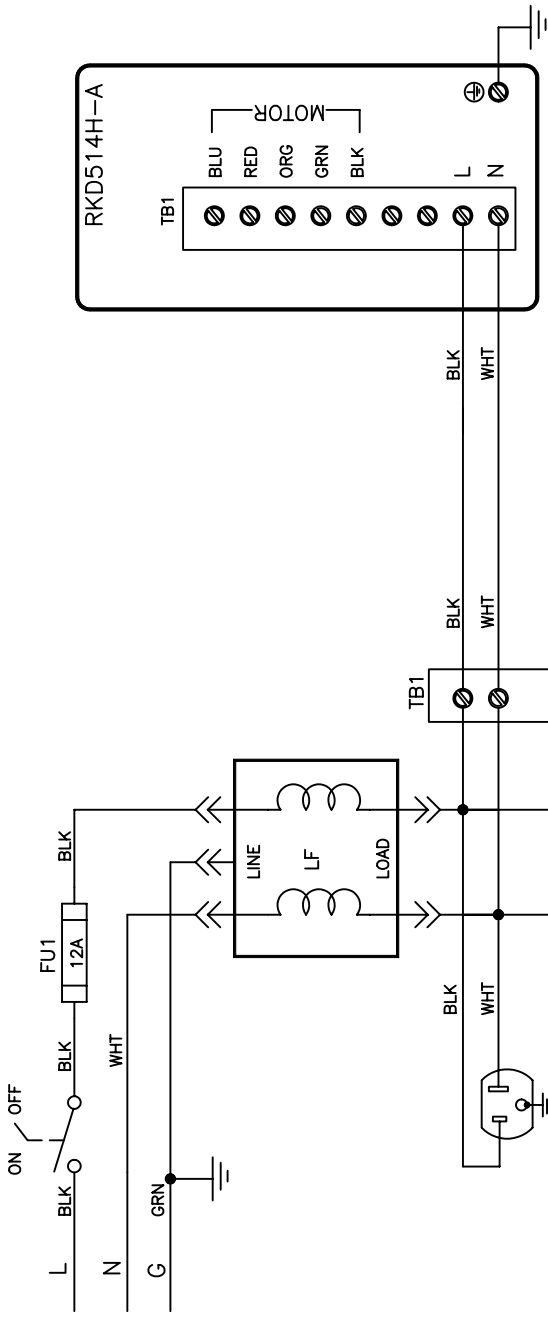

REV	DATE	BY	DESCRIPTION
1			

		Advanced Poly Packaging Inc. 10000 STINE 10000 STINE 10000 STINE
TYPE	SCALE	DATE
1-1000STINE	1:1	05/09/2005
DATE	BY	APPROVED
05/09/2005		
TITLE	110VAC	
	T1KSTNB-E1	

TELEPHONE: 408-734-1100 FAX: 408-734-1101
 WWW: WWW.APPACK.COM
 ALL DIMENSIONS ARE IN INCHES
 PART MUST BE FREE OF BURRS AND SHARP EDGES
 MATERIALS AND MANUFACTURING METHODS
 TO BE DETERMINED BY THE CUSTOMER
 ALL DIMENSIONS ARE IN INCHES
 PART MUST BE FREE OF BURRS AND SHARP EDGES
 MATERIALS AND MANUFACTURING METHODS
 TO BE DETERMINED BY THE CUSTOMER

T-1000

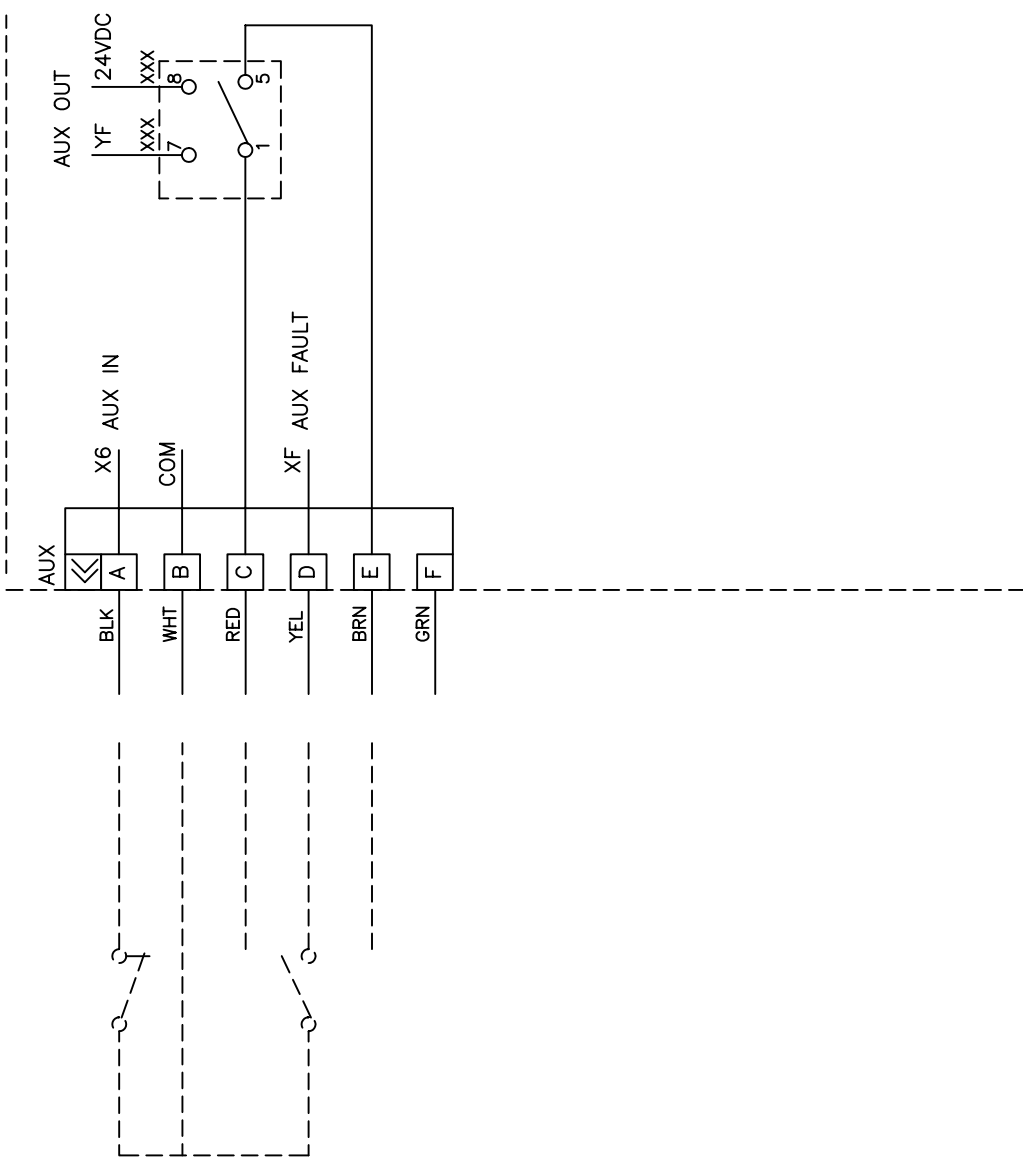

QTY	REV	DATE	BY	DESCRIPTION
 Advanced Poly Packaging Inc. <small>1280 South Main St. Suite 100 Phoenix, AZ 85004 Phone: 602-952-7500</small>				
TYPE CHANGE		DATE		PART NO.
T-1000		04/01/04		T-1000
SCALE		DRAWN BY		APPROVED
1:1		MKS		LF
		DATE		04/12/2008
TITLE		DRAWING NO.		
AUX INTERFACE		T1KST-E7		
		REV.		
		-		

TELETYPE: 1-800-762-4673
 FAX: 602-952-7500
 E-MAIL: SALES@POLYPACKAGING.COM
 WWW: WWW.POLYPACKAGING.COM
 ALL DIMENSIONS ARE IN INCHES
 PART MUST BE FREE OF BURRS AND SHARP EDGES
 NOTES: THIS DRAWING CONTAINS PROPRIETARY INFORMATION
 BELONGING TO ADVANCED POLY-PACKAGING, INC.
 IT IS THE PROPERTY OF ADVANCED POLY-PACKAGING, INC.
 AND IS NOT TO BE REPRODUCED OR TRANSMITTED IN ANY FORM OR BY ANY MEANS, WITHOUT THE PRIOR WRITTEN
 CONSENT OF ADVANCED POLY-PACKAGING, INC.

Item	APPI No.	No. Reqd	Drawing No.	Description
------	----------	----------	-------------	-------------

Material List				
---------------	--	--	--	--

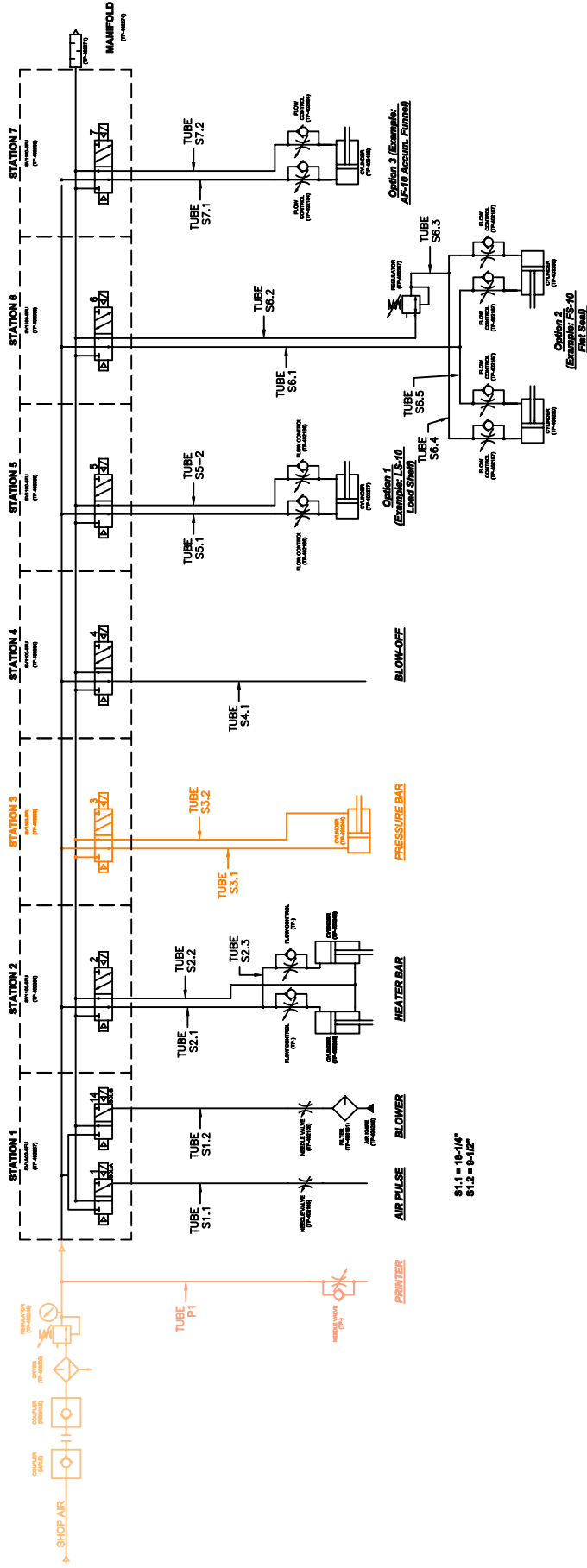

S1.1 = 1/8-1/4"
S1.2 = 9-1/2"

- STATION 1: AIR PULSE / BLOWER
- STATION 2: HEATER BAR
- STATION 3: PRESSURE BAR
- STATION 4: BLOW OFF
- STATION 5: OPTION 1
- STATION 6: OPTION 2
- STATION 7: OPTION 3
- STATION 8: OPTION 4
- STATION 9: OPTION 5
- STATION 10: OPTION 6
- STATION 11: OPTION 7

QUANTITY	MATERIAL	FINISH	EXEMPTION

TOLERANCES UNLESS OTHERWISE SPECIFIED:
 FRACTIONS: AS SHOWN
 DECIMALS: TO PLACE FINAL DIMENSIONS
 DIMENSIONS ARE IN INCHES
 ALL DIMENSIONS ARE TO UNLESS OTHERWISE SPECIFIED
 PARTS MUST BE FREE OF BURRS AND SHARP EDGES
 UNLESS OTHERWISE SPECIFIED
 DIMENSIONS TO BE TAKEN TO CENTER UNLESS OTHERWISE SPECIFIED
 DIMENSIONS TO BE TAKEN TO FACE UNLESS OTHERWISE SPECIFIED
 DIMENSIONS TO BE TAKEN TO CENTER UNLESS OTHERWISE SPECIFIED
 DIMENSIONS TO BE TAKEN TO FACE UNLESS OTHERWISE SPECIFIED

REV	DATE	BY	DESCRIPTION

Advanced Poly-Packaging Inc.
 1000 S. 10th Street, Suite 100, Lincoln, NE 68502
 T-1000-S14
 SIZE: NONE
 DRAWN BY: [Blank]
 CHECKED BY: [Blank]
 INCHES
 TITLE: T-1000-S14 PNEUMATIC CIRCUIT
 DRAWING NO.: PL-S14
 REV.: [Blank]

7.11 PLC IO Listing

Main PLC and Expansion PLC IO (Inputs and Outputs) Listing is provided to assist in troubleshooting the T-1000.

Main PLC	Input	Description	Output	Description
	X0	Stepper Control	Y0	Stepper Motor Forward
	X1	Perforation Sensor	Y1	Stepper Motor Reverse
	X2	Spare	Y2	Perforation Activate
	X3	Spare	Y3	Heater Element
	X4	Spare	Y4	Air Blower Valve#1a
	X5	CF-10 Counting Funnel Photo Sensor	Y5	Air Pulse Valve#1b
	X6	Spare	Y6	Heater Bar Valve#2
	X7	Seal Bar In Sensor - Antijam Defeat	Y7	Seal Bar Out Valve#3a
	X8	Spare	Y8	Seal Bar In Valve#3b
	X9	Bag Out Sensor	Y9	Blow Off Valve#4
	XA	Spare	YA	Spare
	XB	Ti-1000 Ready	YB	Option 1, Valve#5
	XC	Ti-1000 Fault	YC	Spare
	XD	PB-20 Palm Button 1	YD	LC-10 Activate Cycle Operation
	XE	PB-20 Palm Button 2	YE	Ti-1000 Print Initiate
	XF	Spare	YF	Spare
Expansion PLC	X20	Spare	Y20	Spare
	X21	Spare	Y21	Spare
	X22	Spare	Y22	Spare
	X23	Spare	Y23	Spare
	X24	E-Stop Button	Y24	Spare
	X25	LC-10 Light Curtain	Y25	ST-10 Stack Light Red
	X26	DF-20 Diverting Funnel Photo Sensor	Y26	ST-10 Stack Light Green
	X27	IF-10 Insert Funnel Down Sensor	Y27	ST-10 Stack Light Yellow

	X28	BV-10 Barcode Verifier Read	Y28	Spare
	X29	BV-10 Barcode Verifier No Read	Y29	Spare
	X2A	MV-10 Medical Val. Temp. Out of Range	Y2A	Spare
	X2B	MV-10 Medical Val. Pressure Out of Range	Y2B	Spare
	X2C	MV-10 Medical Val. Heater Bar 1 Cylinder Activated	Y2C	Spare
	X2D	BO-20 Bag Open Sensor	Y2D	Spare
	X2E	MV-10 Medical Val. Heater Bar 2 Cylinder Activated	Y2E	BV-10 Barcode Verifier Initiate (Sync)
	X2F	Spare	Y2F	Spare

