

# T-1000

# Advanced Poly-Bagger

---

## Operation Guide

Setup, Operation and Parts Manual (Version 2)





# T-1000

# Advanced Poly-Bagger

---

## Operation Guide

Setup, Operation and Parts Manual



Advanced  
Poly-Packaging, Inc.

---

1331 Emmitt Road, Akron, Ohio 44306  
Phone (800) 754-4403 Fax (330) 785-4010

## Acknowledgments

Manual written by: Stuart Baker  
Drawings by: Melody Cacho

## Copyright

1995, 2001, Advanced Poly-Packaging, Inc. (APPI). All rights reserved.

This manual and the program operating the equipment described in it are copyrighted. You may not copy this manual in whole or part without the consent of Advanced Poly-Packaging, Inc.

All information pertaining to the promotion, sale, distribution, operation, and maintenance of the T-1000 ADVANCED POLY-BAGGER including this manual, drawings, schematic, wiring diagrams, VHF video tapes, brochures, specification sheets, figures, charts, or any other information, due to its proprietary design and manufacture remain the property of Advanced Poly Packaging, Inc. Unauthorized duplication, distribution, or disclosure to third parties without the express permission of Advanced Poly-Packaging, Inc. is strictly prohibited.

## Trademarks

T-1000 Advanced Poly-Bagger is a trademark of Advanced Poly-Packaging, Inc. Advanced Poly-Packaging, Inc. owns also the following trademarks: Advanced Poly-Bags, Twin-Seal, Advanced Poly-Pack, Advanced Poly-Bag, Blist-a-Bag.

## Limited Warranty & Disclaimer

Warranty period is 12 months or 1,000,000 cycles whichever comes first. The warranty commences on the date of delivery of the equipment to the Purchaser.

APPI warrants to the Purchaser that the equipment is free from defects in workmanship or material under normal use and service. During the warranty period, APPI agrees to repair or replace, at its sole option, without charge to Purchaser, any defective component part of the equipment. To obtain service, Purchaser must return the equipment or component to APPI or an authorized APPI distributor or service representative in an adequate container for shipping. Any shipping charges, insurance, or other fees must be paid by Purchaser and all risk for the equipment shall remain with Purchaser until such time as APPI takes receipt of the equipment. Upon receipt, APPI, the authorized distributor or service representative will promptly repair or replace the defective component and then return the equipment or component to Purchaser, shipping charges, insurance and additional fees prepaid. APPI may use reconditioned or like new parts or units, at its sole option, when repairing any component or equipment. Repaired products shall carry the same amount of outstanding warranty as from original purchase. Any claim under the warranty must include a dated proof of delivery. In any event, APPI's liability for defective components or equipment is limited to repairing or replacing the components.

This warranty is contingent upon proper use of the equipment by Purchaser and does not cover: expendable component part such as rollers, bushings, and the like; or if damage is due to accident, unusual physical, electrical, or electromechanical stress, neglect, misuse, failure of electric power, improper environmental conditions, transportation, tampering with or altering of the equipment, packaging of corrosive or contaminating products or other products damaging to components, and equipment or components not owned or in the possession of original Purchaser.

APPI will not be liable for loss of production, profits, lost savings, special, incidental, consequential, indirect, or other similar damages arising from breach of warranty, breach of contract, negligence, or their legal action even if APPI or its agent has been advised of the possibility of such damages or for any claim brought against the Purchaser by another party.

This warranty allocates risks of equipment failure between Purchaser and APPI. APPI's pricing reflects this allocation of risk and the limitations of liability contained in this warranty. The warranty set forth above is in lieu of all other express warranties, whether oral or written. The agents, employees, distributors, and dealers of APPI are not authorized to make modifications to this warranty, or additional warranties binding on APPI. Accordingly, additional statements such as dealer advertising or presentations, whether oral or written, do not constitute warranties by APPI and should not be relied upon.

Warranty on equipment is considered void when outstanding balances become delinquent (over 30 days late - 60 days after ship date).

Equipment Integration to other Equipment: APPI assumes no responsibility for the integration of its products to other products or within a system unless APPI performs the integration, testing and provides the results of the tests to the purchaser in writing. Furthermore, APPI assumes no responsibility for bag sizing whether suggested or recommended.



# Contents

---

## Chapter 1, Introduction

- 1.1 Welcome
- 1.2 Overview
- 1.3 Special Features
- 1.4 System Integration
- 1.5 Options Available
- 1.6 Using This Manual
- 1.7 Registration Information

## Chapter 2, Getting Started

- 2.1 Installation Procedures
- 2.2 Air & Power Requirements
- 2.3 Assembly
- 2.4 Air & Power Hookup
- 2.5 Main Power
- 2.6 Bag Threading
- 2.7 Cycle Operation
- 2.8 Note on Adjustments
- 2.9 Energy Conservation & Component Saver

## Chapter 3, Touch Screen Operation

- 3.1 Touch Screen Front Panel
- 3.2 Touch Screen Back Panel
- 3.3 Specifications
- 3.4 Contrast Adjustments
- 3.5 Touch Screen Program
- 3.6 Intro. Screen
- 3.7 Main Menu
- 3.8 Bag Setup Menu
- 3.9 Seal Time
- 3.10 Seal Temperature
- 3.11 Seal Point
- 3.12 Note on Seal Quality
- 3.13 Air Pulse
- 3.14 Blower
- 3.15 Fill Time
- 3.16 Counters
- 3.17 Options
- 3.18 Accumulating Funnel
- 3.19 Load Shelf
- 3.20 Inline Printer
- 3.21 Counting Funnel

- 3.22 Insert Funnel
- 3.23 Diverting Funnel
- 3.24 Palm Buttons
- 3.25 Light Curtain
- 3.26 Trim Seal
- 3.27 Flat Seal Assembly
- 3.28 Twin Seal™ Assembly
- 3.29 Compartment Seal
- 3.30 Auxiliary Options Setup
- 3.31 Graphs Screen
- 3.32 Job Save / Recall
- 3.33 Technical Assistance
- 3.34 Timers
- 3.35 Passwords
- 3.36 Inputs / Outputs (PLC)
- 3.37 Input / Outputs (Expansion Card)
- 3.38 UF-5000 Operation Screen
- 3.39 UF-5000 Settings Screen
- 3.40 Information Screens
- 3.41 Message Screens

## Chapter 4, Operation, Settings & Adjustments

- 4.1 Machine Adjustments
- 4.2 Tracking & Alignment
- 4.3 Compression (Nip) Roller Adjustment
- 4.4 Dancer Assembly
- 4.5 Dancer Bar & Brake Strap
- 4.6 Upper Roller Guides
- 4.7 PTFE Anti-Stick Adjustment
- 4.8 PTFE Anti-Stick Replacement
- 4.9 Pressure Bar Adjustment
- 4.10 Drive Belt Tension
- 4.11 Seal Cylinder Adjustment
- 4.12 Pressure Bar Rubber Replacement
- 4.13 Anti-jam Adjustment
- 4.14 Heater Cartridge Replacement
- 4.15 Thermocouple Wire Replacement
- 4.16 Brake Gap Adjustment
- 4.17 Battery Replacement
- 4.18 PLC E-Prom Installation Instructions

## Chapter 5, Parts

- 5.1 Machine Assembly
- 5.2 Head Assembly
- 5.3 Flat Load Shelf Sub-Assembly
- 5.4 Main Frame Assembly
- 5.5 Main Frame Assembly
- 5.6 Inner Main Frame Assembly

- 5.7 Upper Roller Finger Assembly
- 5.8 Air Knife Assembly
- 5.9 Outer Main Frame Assembly
- 5.10 Pneumatics Mntg. Valve
- 5.11 Electrical Panel Assembly
- 5.12 Sealer Frame Assembly
- 5.13 Seal Frame Manifold Sub-Assembly
- 5.14 Pressure Bar Sub-Assembly
- 5.15 Heater Bar Sub-Assembly
- 5.16 PTFE Anti-Stick Guide Sub-Assembly
- 5.17 Grooved Roller Mounting Sub-Assembly
- 5.18 Bag Finger Grounding Assembly
- 5.19 Stand Assembly
- 5.20 Base Assembly
- 5.21 Upper Column Assembly
- 5.22 Dancer Assembly
- 5.23 Dancer Guide Sub-Assembly
- 5.24 Touch Screen Assembly
- 5.25 SP-10 Spare Parts Kit (Level 1)
- 5.26 SP-20 Spare Parts Kit

## Chapter 6, Preventive Maintenance & Scheduled Maintenance

- 6.1 Preventative Maintenance & Schedule Maintenance
- 6.2 P.M. Checklist
- 6.3 Scheduled Maintenance Chart

## Chapter 7, Trouble-Shooting

- 7.1 Trouble-shooting
- 7.2 Trouble-shooting Checklist
- 7.3 Interface PCB Voltage Table
- 7.4 Wiring Tab List
- 7.5 Circuit Boards
- 7.6 Pneumatic Valves / Cylinders
- 7.7 Wiring Diagram
- 7.8 Notes

This page intentionally left blank.

# Operation Guide

---

## Chapter 1, Introduction

Welcome

Overview

Special Features

System Integration

Options Available

Using This Manual

Registration Information

## 1.1 Introduction

Now that you've decided to upgrade your packaging facilities with the T-1000 Advanced Poly-Bagger from Advanced Poly-Packaging, Inc., we thank you for selecting our equipment, materials and service. Where labor reduction and fast changeover is important, the T-1000 uses Advanced Poly-Bags (pre-opened bags on rolls), manufactured by Advanced Poly-Packaging, Inc. Extensively equipped with several "built-in", ready-to-use options, the T-1000 can package various industrial, medical, molded and food products. With a wide range of bag sizes (2" x 3" to 14" x 30") and mil thickness (1 mil to 5 mil), we hope the T-1000 will meet all of your bagging needs.

## 1.2 Overview

The T-1000 ADVANCED POLY-BAGGER™ is a system designed to lower your packaging costs with high speeds, versatility, reliability, and simplicity.

**High Speeds** - Indexes, opens, seals and tears off a bag at rates over 100 cycles per minute, dependent upon bag size and product characteristics.

**Versatility** - Mobile on rugged castors for packaging at any production station throughout your facility. Ideal for numerous short runs with virtually no production loss for job changeovers since all that is required is a roll change and recalling the bag settings from memory.

**Reliability** - Crafted from the highest quality components and materials to withstand the most rigorous manufacturing environment; sturdy mounts with castors, and rugged frame guarantee long life and usefulness with minimal maintenance.

**Simplicity** - A "user-friendly" menu-driven touch screen program allows operators to setup the bag, options and auxiliary equipment, save the settings in memory, and recall those settings for repeat runs.

## 1.3 Special Features

**Energy Conservation & Component Saver** - To extend its life and conserve energy in your plant, the T-1000 is programmed to sequentially shut components down when not in use for extended periods. First, the motor will shut off until the foot switch is pressed or a signal is received to initiate operation. Later, current to the heater bar will discontinue and place the T-1000 in the stop mode. Shortly thereafter, air flow will be shut off preserving compressed air. A screen saver is also provided.

**Predetermined Counter** - Preset the T-1000 to stop after a predetermined number of bags have been packaged. Set the quantity of finished bags to complete a work order or fill a shipping container. Once the work order is complete or the container is full, the T-1000 stops to alert the operator to begin the next work order or to push aside the box to begin filling another. Pressing anywhere on the screen resets the counter and starts the bagging operation with minimum delay.

**Totalizing Counter** - Reset this counter at the beginning of each shift or day to record packaging production over a period of time.

**Maintenance Counter/Chart** - Periodically check this counter (total machine cycles) to determine preventative maintenance / component inspection intervals for inspection / maintenance criteria and intervals.

**Continuous Strip Option** - Leave bags connected in an "endless" strip or a predetermined number of strips of sealed bags.

**Networking Capability** - Allows remote access to PLC for production and status reports.

**Communications Port/Modem** - Allows for auxiliary communications.

**Anti-Jam Device** - During the loading and sealing operation, this device will detect obstructions and automatically reverse the pressure bar and discontinue the cycle operation.

**Castors Assembly** - Rugged castors are standard for plant mobility.

## 1.4 System Integration

The T-1000 is preprogrammed to integrate automatically to major brand vibratory counters and feeders, weigh scales, volumetric fillers, auger fillers and infeed conveyors. As an OEM for numerous equipment manufacturers of infeed systems, we can offer the best available system, with the T-1000 Advanced Poly-Bagger as the integral packaging component.

**FREE CONSULTATION AND PRODUCT EVALUATION:** We invite you to call to discuss your packaging requirements and our free product packaging analysis.

## 1.5 Additional Options Available

Although the T-1000 is extensively equipped with many "built-in" options described above, various auxiliary options and equipment can easily be added for special purpose packaging. The following options may be purchased from Advanced Poly-Packaging, Inc.

**AF-10 Accumulating Funnel** - Increase production by allowing a continuous infeed of product into the funnel without regard for the operation of the T-1000. The Accumulating Funnel will collect the product while the bag is sealing. Once another bag is in position and blown open, the funnel discharges the product into the bag without stopping the flow of product into the funnel.

**BB-10 Bag Blow-off Assembly** - Allows for faster packaging of lighter products by stripping bags from seal bar. Also used when bags stick to PTFE Anti-Stick Sheet or seal bar.

**BF-10 Bag Deflator** (sponge or rubber loop) - Flattens package by removing air from bag before sealing.

**CF-10 Counting Funnel** - Preprogrammed, the T-1000 Counting Funnel counts product entering the funnel or bag and signals the T-1000 to seal the bag when the preset quantity has been reached. The Counting Funnel may operate in conjunction with the Accumulating Funnel for fully automatic operations.

**DF-10 Diverting Funnel** - Mounts to bagger beneath the seal bar or the end of a takeaway conveyor to count bags into one of two boxes. When the final bag count is reached, a diverter redirects from Box A to Box B.

**FS-10 Flat Seal Assembly** - Helps decrease / eliminate wrinkles in the seal by pulling sides of bag. Increase bag integrity.

**LS-10 Load / Support Shelf** - Provides support for heavier packages when dropped into bag. Sizes: 10", 15", or 20" long.

**LSV-10 Load Shelf Vibrator Kit** - Settles product to bottom of bag to increase volume of product in bag. (LS-10 back plate required).

**PB-20 Dual Palm Buttons** - Decrease the possibility of injury to hands and fingers. Operator must push two buttons simultaneously to actuate seal bar.

**LC-10 Light Safety Curtain** - Safety feature that prohibits seal operation when there are obstructions in light screen. Also, toggle on the "auto cycle" feature and the seal bar automatically activates when the light curtain field is unobstructed (trailing edge of signal).

**Printpad Terminal & Scanner** - No longer is a PC required to operate a thermal transfer printer. Alphanumeric keypad with programmable function keys, printer controls, easy-to-read display, scanned input, and stored databases. Data can be imported directly from external devices such as scales or other test and measurement equipment. Designed for an industrial environment, this compact unit is sealed for protection and costs less than most PCs.

**TS-10 Trim Seal Assembly** - Trims excess film from bag above seal to enhance the appearance of the package (retail products).

**Ti-1000 Thermal Transfer Inline Printer** - Print bar codes, graphics, etc. by downloading pre-formatted labels, generated via label software. (PC or Terminal & software required)

**Ti-2000 Dual Thermal Inline Printers** - Print bar codes, graphics, etc. on both front and back of bag, directly to the surface of the bag, simultaneously with a "top & bottom" printer. (PC or terminal & software required)

**Twin-Seal™** - Seal the bag a second time, 3/4" from the first seal for additional bag integrity.

**UF-2000 Takeaway Conveyor** - Remove the packaged product to a packing station or directly feed a carton or table, conveying the product from floor level. The conveyor perfectly fits underneath the T-1000 and takes the product away. Small, lightweight and equipped with castors, use this conveyor anywhere in the plant. Designed for 24 hour / 7 days a week operation.

**UF-5000 Infeed Conveyor** - Kit packaging infeed conveyor. Instead of loading parts directly into the bag, load parts into compartments on the conveyor. Packaging kits loading the compartments by hand or automatically with parts counters or scales.



UC-2400 Vibratory Parts Counter - Automatic parts counter feeds fasteners, electronic components, injected molded parts and many other types of products, then drop the final count into the bag, carton or infeed conveyor.

US-5000/7000/9000 - Semi automatic (US-5000) or automatic scale (US-7000 & US-9000) feeds a weigh / counted batch of product into bags.

Other options may have been added since the date this list was printed. Please call for additional or custom options pricing.

## 1.6 Using this Manual - Typographical Conventions

The following manual conventions are frequently used to assist in understanding important information, alerting the operator of potentially dangerous or damaging practices, and the normal functions of the T-1000 Advanced Poly-Bagger™.

text                      Normal text

<ENTER>                Used to show Touch Screen keys

*Italics*                      Used for emphasis

**CAUTION:**                Warning messages: To avoid physical harm, damage to equipment or damage to the product. Be sure to read these messages carefully.

## 1.7 REGISTRATION INFORMATION:

(This section must be completed and returned to Advanced Poly Packaging, Inc. to register the T-1000 for Warranty Protection)

Company Name & Address	Contact Name(s) / Title(s) / Phone Number

This page intentionally left blank.

# Operation Guide

---

## Chapter 2, Getting Started

Installation Procedures

Assembly Instructions

Height Adjustment

Air & Power Hookup

Bag Threading

## 2. Getting Started

This chapter describes in detail procedures to receive and setup the T-1000, including uncrating, environmental, air and power requirements, assembly, and height adjustments. Additionally, this chapter describes how to turn on power to the T-1000 and properly thread bags through the machine.

### 2.1 Installation Procedures

The T-1000 is transported as a single unit in a custom crate designed to protect the machine during shipment. It is shipped completely assembled except for a few items which are easily attached during installation with final adjustment for proper placement of touch screen, dancer assembly, foot switch, funnel and guards.

**Unpacking:** After removing the stretch wrapping, remove the outer crate from the skid which contains the T- 1000. Unfasten the base support brace from the skid. Carefully lower the T-1000 from the skid. Transport the T-1000 to the operating location prior to placing the Touch Screen in position and unfastening the dancer assembly.

**Operating Environment:** The T-1000 should be placed in an area free of excessive heat, moisture, dirt and dust. Operating room temperature should range from 50 to 100 degrees Fahrenheit.

### 2.2 Air & Power Requirements

**Power Requirements:** Provisions must be made for 115 VAC, 50/60 Hz line current with ground. Full Load Current for T-1000: 12 AMPS.

*CAUTION: A qualified electrician should ensure that the T-1000 power outlet is properly grounded, voltages are as required and amperage capacity is sufficient. Note: APPI recommends a dedicated 20 Amp circuit for the T-1000.*

**Air Requirements:** At least 2 CFM free air is required, regulated to 80 PSI. *Note: Air should be dry and oil-free.*

### 2.3 Assembly Instructions

Choose an operating location considering traffic flow, availability of bag supplies, supply of product to be packaged, takeaway of finished packages, placement of auxiliary infeed equipment and placement of takeaway conveyor(s). Operating location, the first step is to remove any inner packaging, banding or wires.

**Touch Screen Assembly/Position:** The Touch Screen has been secured for transportation in a positioned "face in" with protective wrapping. Holding the Touch Screen preventing it from falling, loosen the set screw located in the clamp collar at the top of the upper "T" column. Pull the shaft from the clamp collar approximately 6" and tighten the collar. Holding the Touch Screen module, loosen the "ball" clamp lever and position the touch screen. (Fig 2-1).

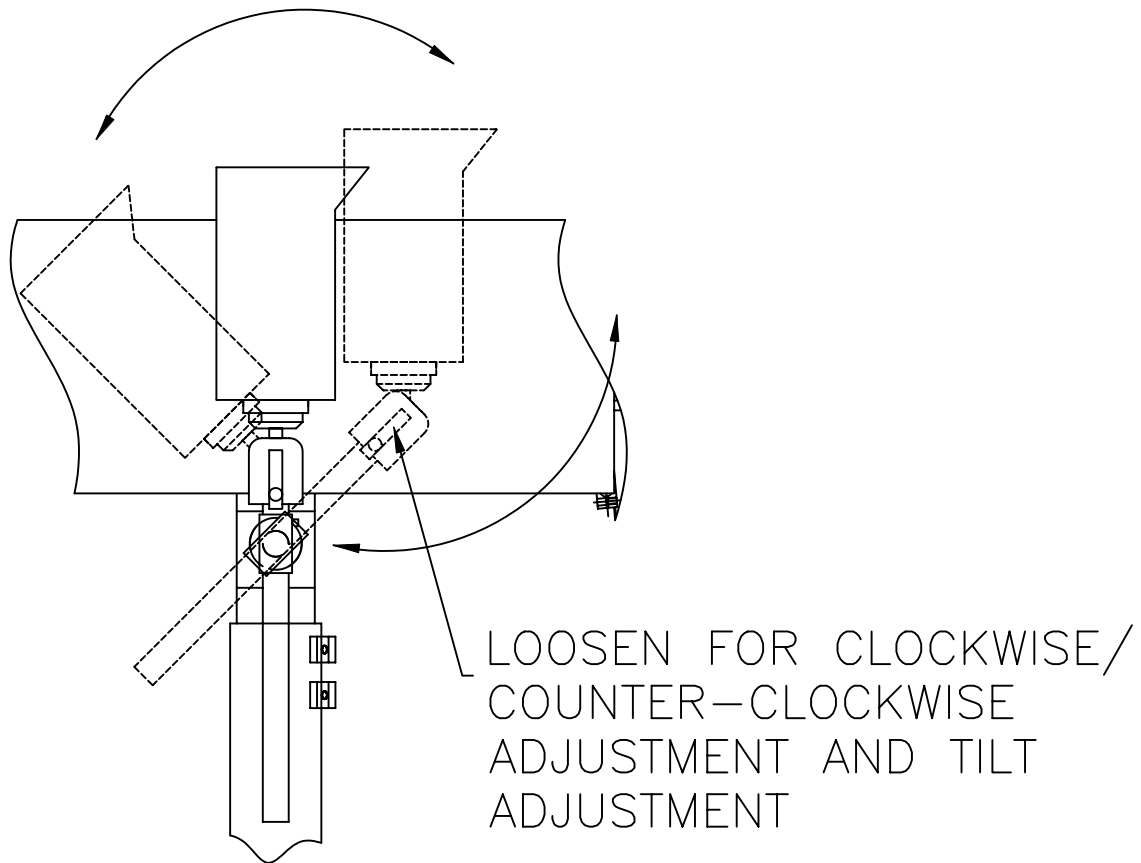
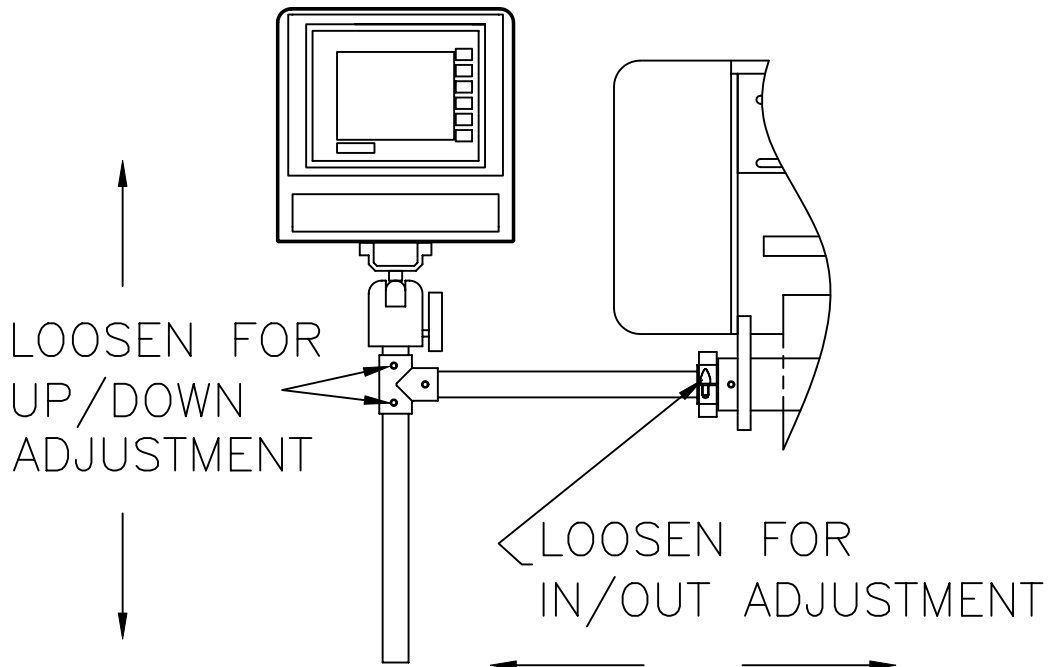

QUANTITY	-
MATERIAL	-
FINISH	-
TOLERANCES UNLESS OTHERWISE NOTED: +/- .015 ON FRACTIONAL DIMENSIONS +/- .010 ON TWO PLACE DECIMAL DIMENSIONS +/- .003 ON THREE PLACE DECIMAL DIMENSIONS 125 ✓ ON MACHINED SURFACES ALL DIMENSIONS ARE IN INCHES PART MUST BE FREE OF BURRS AND SHARP EDGES	
NOTICE: THIS DOCUMENT CONTAINS PROPRIETARY INFORMATION AND IT SHALL NOT BE USED OR REPRODUCED OR ITS CONTENT DISCLOSED, IN WHOLE OR PART, WITHOUT THE PRIOR WRITTEN CONSENT OF ADVANCED POLY-PACKAGING INC.	

FIGURE 2-1			
 <b>Advanced Poly Packaging Inc.</b> <small>1331 Ewitt Road • Akron • Ohio 44306          Phone: 330-789-6900 • Fax: 330-789-6910</small>			
TYPE EQUIPMENT	B/M REF. NDL	PART NDL	
T-1000		-	
SCALE	DRAWN BY	APPROVED	
1:3	NAME MELODY	NAME	
	DATE 12/13/01	DATE	
TITLE	DRAWING NDL	REV.	
I.O.P ASSEMBLY & POSITION	TP-T1D01	-	

*CAUTION: To avoid damage to the Touch Screen module, hold the Screen until it is in the desired position and then be sure the screws and ball clamp lever are securely tightened.*

**Dancer Assembly:** The dancer assembly, located on the stand at the rear of the T-1000, is secured with tape strapping during shipment. After the removal of the strapping, the dancer should be checked to make sure that it will rotate freely in a semicircular path. Ensure the brake strap and brake tension spring remain affixed to the dancer assembly. The shaft assembly may then be inserted into the dancer frame brackets so it is over the brake stop for tension. Once the bag roll shaft is inserted, the brake strap will be in a position under the bag roll shaft with a slight amount of tension on the dancer assembly. The dancer should be checked to insure that it rotates freely.

**Funnel Assembly & Adjustment:** One standard funnel, any size, is provided with the T-1000. Other sizes and configurations may be purchased separately. Mount the funnel brackets to the funnel using thumb-knob screws through the three-slotted side of the brackets (Fig. 2-3). The three slots are provided for height adjustment of the funnel.

With both the left and right bracket fastened to the funnel, position the funnel such that the small end of the funnel lies approximately 1/2" above the center of the seal bar. Secure the brackets to the upper face-plate slots with thumb-knob screws through the slotted brackets. Position and hand-tighten the thumb-knob screws, sliding the funnel left or right centering the funnel over the bag. Fine adjustments of the funnel may be achieved, including left to right, up and down, front to back and tilt angles.

*CAUTION: Seal bar should not come in contact with the funnel during sealing. Raise the funnel to avoid contact.*

**Guard:** Mount the Plexiglas guard by first loosening the two nuts at the end of each extension rod. Then remove one of the two washers from each extending rod, leaving one washer in place. Position the guard on the extension rods so that the ends of each rod extend through the two holes on front of the guards. Replace the washers and nuts and securely fasten.

*CAUTION: Do not operate the T-1000 without a funnel, guard or covers properly positioned.*

**Machine Height Adjustment:** The height of the T-1000 is adjustable. To change the height of the machine, three (3) people total are required. With two people holding the weight of the machine, loosen the two bolts located on the leg, clamping the outer leg to the inner leg (Fig 2-4). Raise or lower the T-1000 to the desired height, and tighten the two bolts.

*CAUTION: Unless properly supported the T-1000 will drop suddenly when loosening the height adjust bolts.*

*CAUTION: Do not attempt to adjust the height without the assistance of at least two other people supporting the weight .*

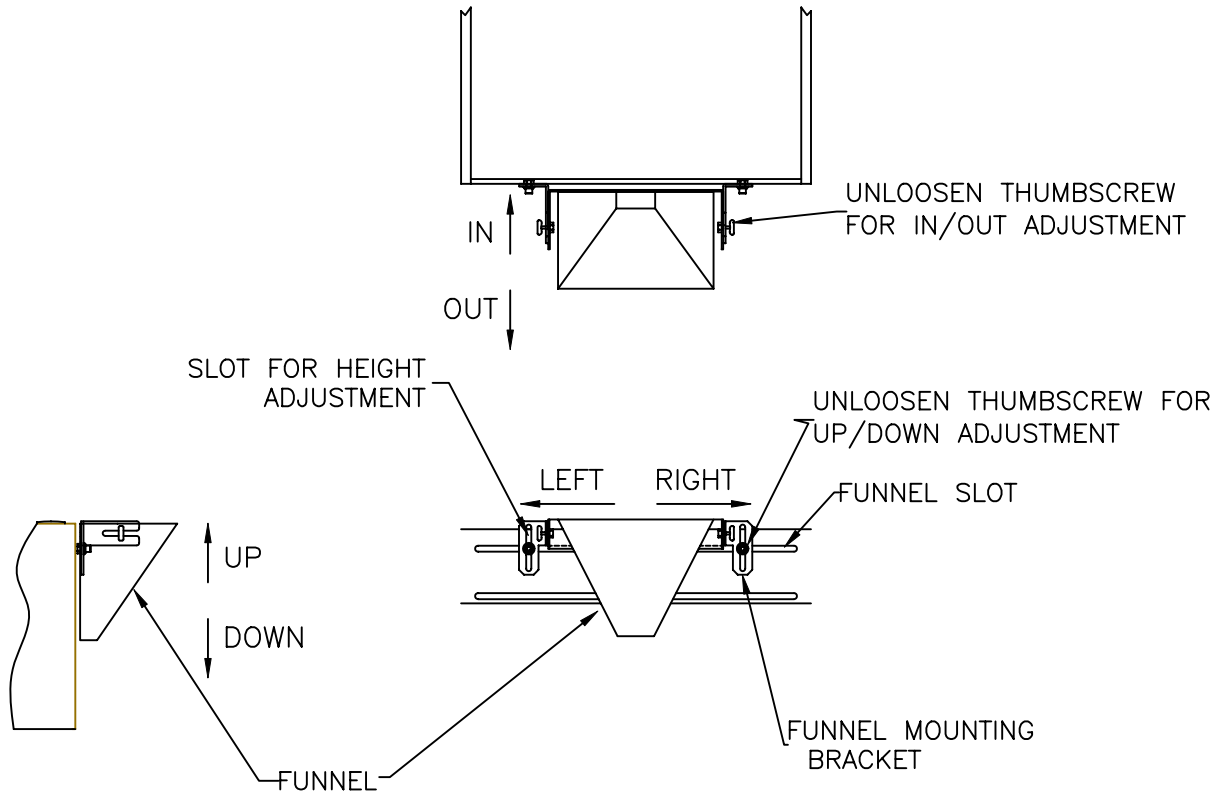

FIGURE 2-3



1201 Everett Road • Alton • Ohio 44306  
 Phone: 330-795-4000 • Fax: 330-795-1999

TYPE EQUIPMENT	B/M REF. NO.	PART NO.
T-1000		
SCALE	DRAWN BY	APPROVED
1:4	NAME	NAME
	DATE	DATE
	10/18/01	
TITLE	DRAWING NO.	REV.
FUNNEL ASSEMBLY AND ADJUSTMENT	TP-T1D02	

NOTICE THIS DOCUMENT CONTAINS PROPRIETARY INFORMATION AND IT SHALL NOT BE USED OR REPRODUCED OR ITS CONTENT DISCLOSED, IN WHOLE OR PART, WITHOUT THE PRIOR WRITTEN CONSENT OF ADVANCED POLY-PACKAGING INC.

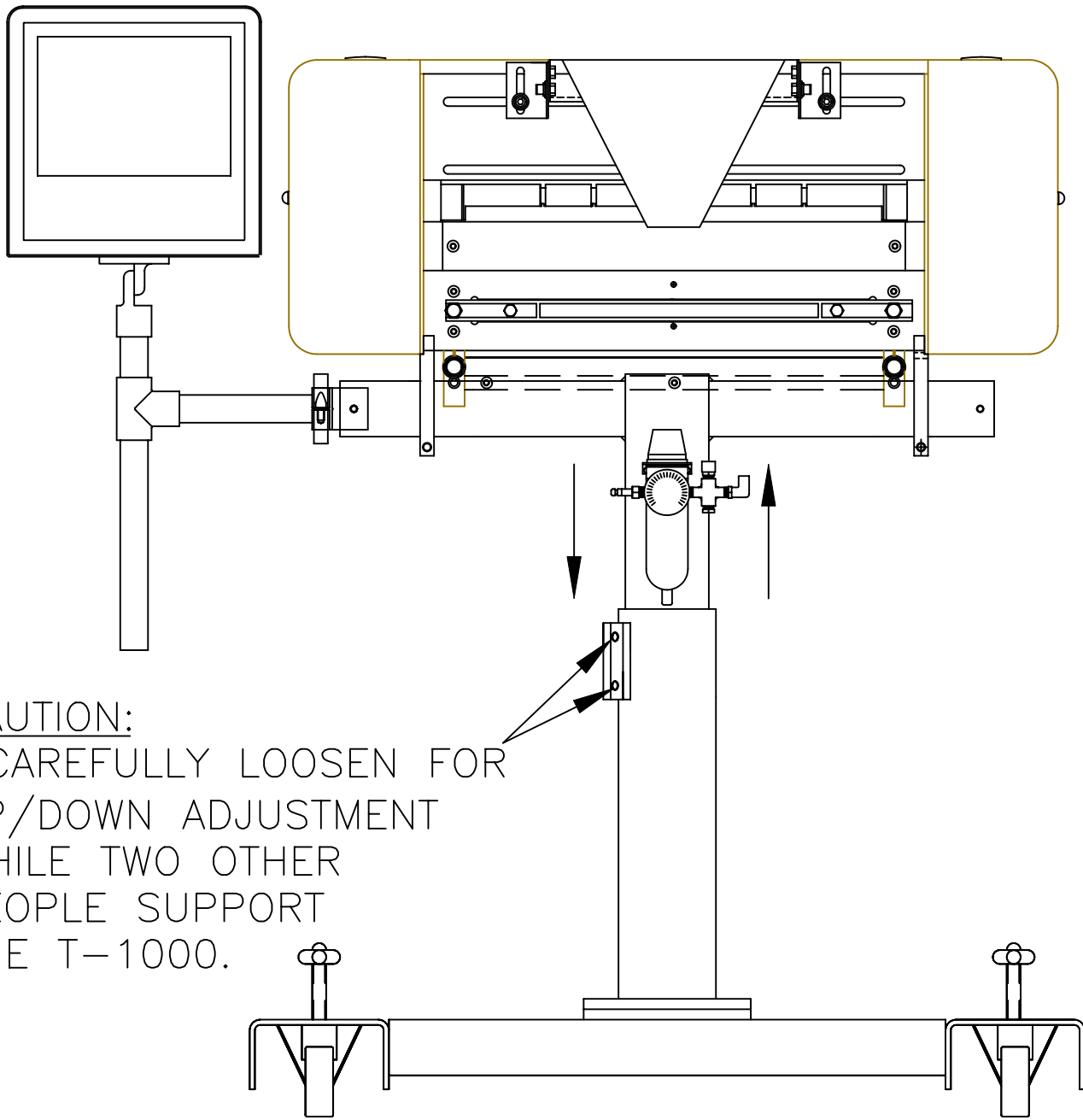

CAUTION:  
 CAREFULLY LOOSEN FOR  
 UP/DOWN ADJUSTMENT  
 WHILE TWO OTHER  
 PEOPLE SUPPORT  
 THE T-1000.

CAUTION:  
 DUE TO THE WEIGHT OF BAGGER,  
 MACHINE MAY DROP SUDDENLY AND MAY  
 CAUSE SEVERE INJURY, IF NOT HELD IN  
 POSITION BY TWO PEOPLE.

QUANTITY	-
MATERIAL	-
FINISH	-
TOLERANCES UNLESS OTHERWISE NOTED: +/- .015 ON FRACTIONAL DIMENSIONS +/- .010 ON TWO PLACE DECIMAL DIMENSIONS +/- .003 ON THREE PLACE DECIMAL DIMENSIONS 125 ✓ ON MACHINED SURFACES ALL DIMENSIONS ARE IN INCHES PART MUST BE FREE OF BURRS AND SHARP EDGES	
NOTICE: THIS DOCUMENT CONTAINS PROPRIETARY INFORMATION AND IT SHALL NOT BE USED OR REPRODUCED OR ITS CONTENT DISCLOSED, IN WHOLE OR PART, WITHOUT THE PRIOR WRITTEN CONSENT OF ADVANCED POLY-PACKAGING INC.	

FIGURE 2-4			
 Advanced Poly Packaging Inc. <small>1331 Ennitt Road ■ Akron ■ Ohio 44306          Phone: 330-785-6000 ■ Fax: 330-785-6010</small>			
TYPE EQUIPMENT	B/M REF. NO.	PART NO.	
T-1000		-	
SCALE	DRAWN BY	APPROVED	
1:3	NAME MELODY	NAME	
	DATE 12/13/01	DATE	
TITLE	DRAWING NO.	REV.	
MACHINE HEIGHT ADJUSTMENT	TP-TC01	-	



## 2.4 Air & Power Hookup

This section describes in detail how to hook up air and power and the air and power requirements. *Note: A qualified electrician should ensure power outlets are the required 115 VAC and properly grounded before hooking up the power.*

The air supply should be fed to the T-1000 with 3/8 ID flexible tubing; this tubing affixes to the coupler adapter (quick disconnect not provided). Connect the air to the regulator by holding the regulator firmly in one hand and pushing the air line connector on the male regulator connector. After connecting air, the regulator should be adjusted so the gauge reads 80 PSI. Insert the T-1000 power cord into a 115 VAC, 50/60 Hz, grounded power outlet.

## 2.5 Main Power

The main power switch is located on the rear panel (Fig. 2-5). Press the switch to ON position so that the Red main power light is illuminated. When the power is in the ON position, the Touch Screen will power up displaying the Introduction Screen. The program version will also be identified. The introduction screen will only appear for a few seconds until automatically changing to the MAIN MENU. *Note: If the Touch Screen does not power up to the Introduction "T-1000" screen, see Chapter 6, Trouble- shooting steps.*

## 2.6 Bag Threading (Fig. 2-6 & 2-7, Threading Diagrams)

The first step to threading the machine is to place a roll of bags on the shaft. Remove one of the chucks from the shaft by loosening the chuck knob and slide the roll of bags over the shaft, locking the chuck pin in the small hole in the core plug. Tighten the knob. Replace the second chuck also locking the chuck pin to the core plug. Remove the tape from the bags so that the bags fall freely and hang down from the top of the roll towards the back of the machine. Insert the right side of the roll shaft in the right side of the shaft holder (circular holder). Then drop the roll shaft in the slot located on the left side of the dancer assembly. See Fig. 2-2 and 2-8.

Center the bags on the shaft by loosening the chuck knobs and sliding the roll of bags along with the chucks to the desired location. Ensure the chuck pins remain in the core plug holes when sliding left or right. Pull the bags over the roller immediately above the dancer assembly, then down between the roll of bags and the outer dancer roller. Pull the bags around the outer dancer roller, over the rear "guide" roller and into the back of the T-1000. Push the bags at least half way through the machine.

From the front of the T-1000, lower the frame by slowly pulling the frame handle forward and downward. See Fig. 2-9. Carefully reach inside and pull the bags through the front of the T-1000 so that one bag is centered on the roller. Ensure only one (1) bag extends through the front of the machine. Slowly raise the frame by pulling forward and upward on the handle while holding the bag in position. Holding the guide roller shaft, slide the Roller Guides within approximately 1/8" from the sides of the bag to assist the tracking of the web of bags.

*Caution: Roller "Fingers" may be sharp. To avoid injury when reaching into the T-1000, ensure that you do not come in contact with the roller "fingers."*

*Note: The Roller Guides are for fine adjustments only, after proper tracking has been achieved. If the web of bags are not properly tracking, make proper adjustments. If not tracking properly, the web of bags may "ride" up the side of the guides causing the bags to fold over.*

# LEFT PANEL

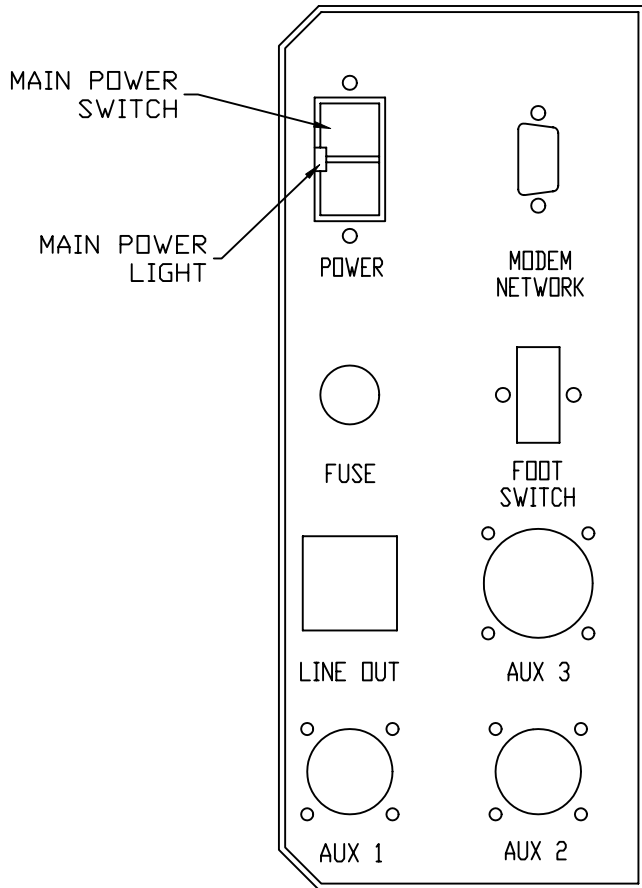

## FIGURE 2-5



Advanced  
Poly Packaging Inc.

1331 Emmitt Road \* Akron \* Ohio 44306  
Phone: 330-785-4000 \* Fax: 330-785-4010

TYPE EQUIPMENT T-1000		B/M REF. NO.	PART NO.
SCALE 1:2		DRAWN BY NAME MELODY DATE 12/4/01	APPROVED NAME DATE
TITLE ELECTRICAL & PNEUMATICS BACK PLATES		DRAWING NO. TP-T1E04	REV.

NOTICE: THIS DOCUMENT CONTAINS PROPRIETARY INFORMATION AND IT SHALL NOT BE USED OR REPRODUCED OR ITS CONTENT DISCLOSED, IN WHOLE OR PART, WITHOUT THE PRIOR WRITTEN CONSENT OF ADVANCED POLY-PACKAGING INC.

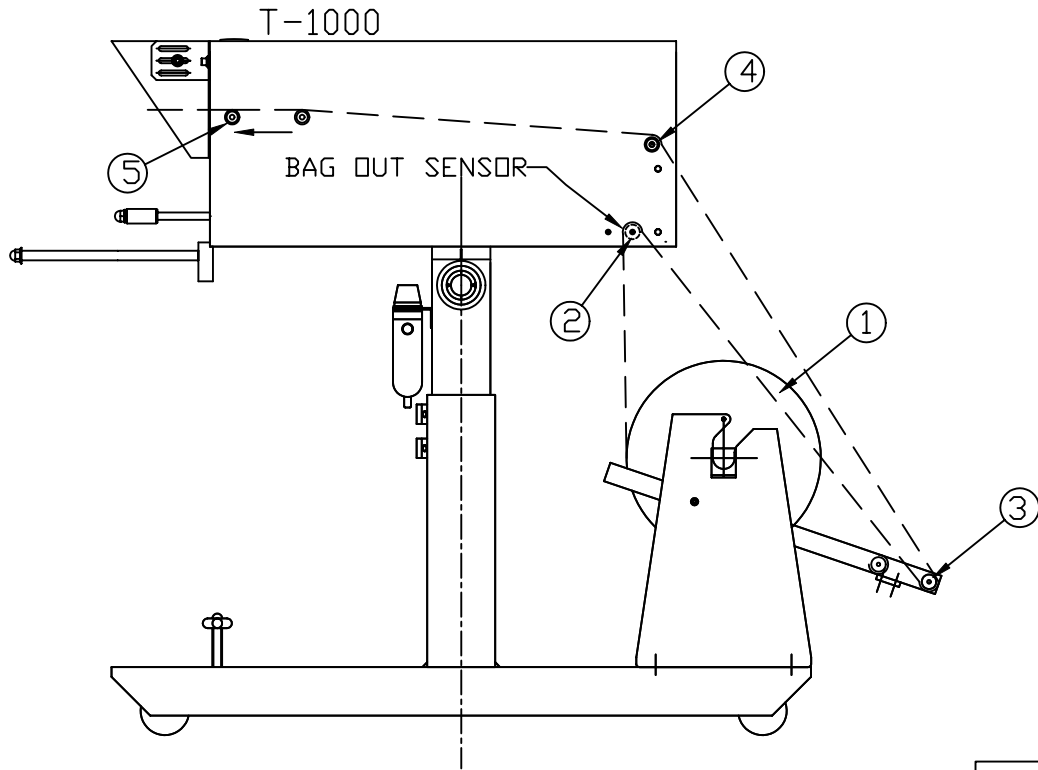



FIGURE 2-6

 <b>Advanced Poly Packaging Inc.</b> <small>1201 Everett Road • Alton • Ohio 44026          Phone: 330-785-0000 • Fax: 330-785-5100</small>			
TYPE EQUIPMENT	B/M REF. NO.	PART NO.	
SCALE	DRAWN BY	APPROVED	
1:4	NAME MELODY	NAME	
	DATE 12/04/01	DATE	
TITLE	DRAWING NO.	REV.	
THREADING DIAGRAM	TP-T1T01		

NOTICE: THIS DOCUMENT CONTAINS PROPRIETARY INFORMATION AND IT SHALL NOT BE USED OR REPRODUCED OR ITS CONTENT DISCLOSED, IN WHOLE OR PART, WITHOUT THE PRIOR WRITTEN CONSENT OF ADVANCED POLY-PACKAGING INC.

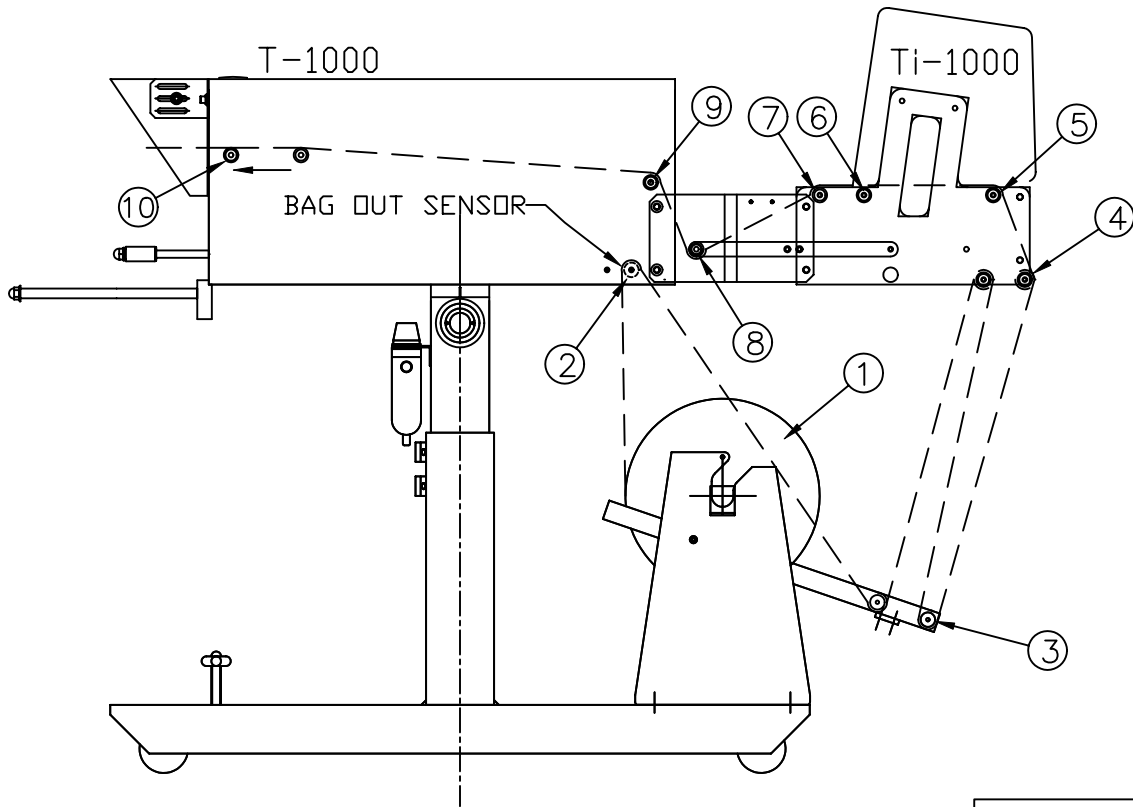

FIGURE 2-7

 Advanced Poly Packaging Inc.

1326 Everett Road • Alton • Ohio 44026  
Phone: 330-785-6000 • Fax: 330-785-6000

TYPE EQUIPMENT	B/M REF. NO.	PART NO.
SCALE	DRAWN BY	APPROVED
1:4	NAME	MELODY
	DATE	12/04/01
TITLE	DRAWING NO.	REV.
THREADING DIAGRAM	TP-T1T02	

NOTICE: THIS DOCUMENT CONTAINS PROPRIETARY INFORMATION AND IT SHALL NOT BE USED OR REPRODUCED OR ITS CONTENT DISCLOSED, IN WHOLE OR PART, WITHOUT THE PRIOR WRITTEN CONSENT OF ADVANCED POLY-PACKAGING INC.

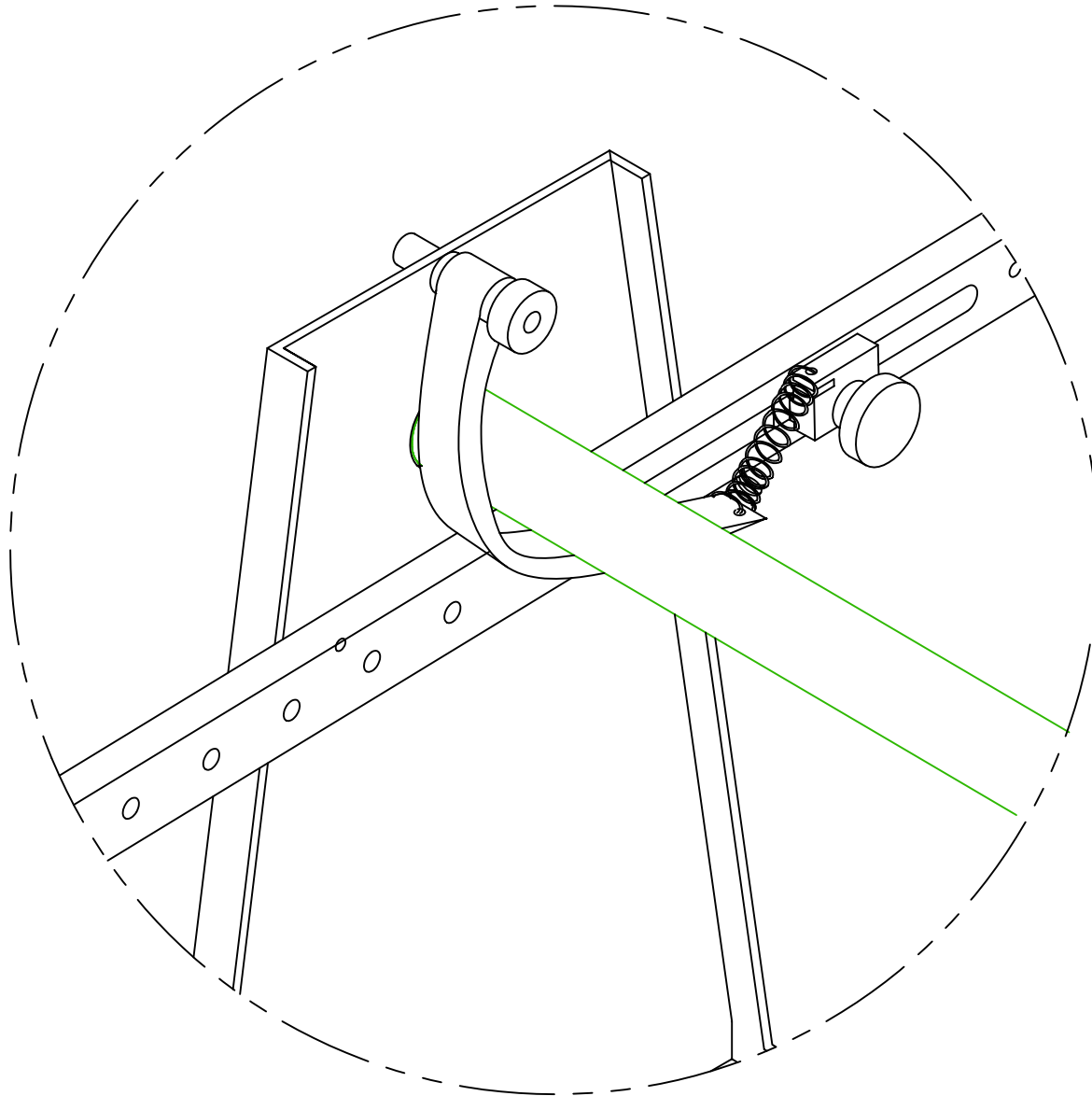

QUANTITY		-		FIGURE 2-2																
MATERIAL		-		 <b>Advanced Poly Packaging Inc.</b> <small>1331 Ewitt Road ■ Alton ■ Ohio 44306          Phone: 330-789-4900 ■ Fax: 330-789-4010</small>																
FINISH		-		<table border="1"> <tr> <td>TYPE EQUIPMENT</td> <td>B/M REF. NDL</td> <td>PART NDL</td> </tr> <tr> <td>T-1000</td> <td></td> <td>-</td> </tr> <tr> <td>SCALE</td> <td>DRAWN BY</td> <td>APPROVED</td> </tr> <tr> <td>1:1</td> <td>NAME MELODY</td> <td>NAME</td> </tr> <tr> <td>DATE</td> <td>12/05/01</td> <td>DATE</td> </tr> </table>		TYPE EQUIPMENT	B/M REF. NDL	PART NDL	T-1000		-	SCALE	DRAWN BY	APPROVED	1:1	NAME MELODY	NAME	DATE	12/05/01	DATE
TYPE EQUIPMENT	B/M REF. NDL	PART NDL																		
T-1000		-																		
SCALE	DRAWN BY	APPROVED																		
1:1	NAME MELODY	NAME																		
DATE	12/05/01	DATE																		
TOLERANCES UNLESS OTHERWISE NOTED: +/- .015 ON FRACTIONAL DIMENSIONS +/- .010 ON TWO PLACE DECIMAL DIMENSIONS +/- .003 ON THREE PLACE DECIMAL DIMENSIONS 125 ✓ ON MACHINED SURFACES ALL DIMENSIONS ARE IN INCHES PART MUST BE FREE OF BURRS AND SHARP EDGES				<table border="1"> <tr> <td>TITLE</td> <td>DRAWING NDL</td> <td>REV.</td> </tr> <tr> <td>DANCER ASSEMBLY</td> <td>TP-2-2</td> <td>-</td> </tr> </table>		TITLE	DRAWING NDL	REV.	DANCER ASSEMBLY	TP-2-2	-									
TITLE	DRAWING NDL	REV.																		
DANCER ASSEMBLY	TP-2-2	-																		
<small>NOTICE: THIS DOCUMENT CONTAINS PROPRIETARY INFORMATION AND IT SHALL NOT BE USED OR REPRODUCED OR ITS CONTENT DISCLOSED, IN WHOLE OR PART, WITHOUT THE PRIOR WRITTEN CONSENT OF ADVANCED POLY-PACKAGING INC.</small>																				

SHAFT  
HOLDER

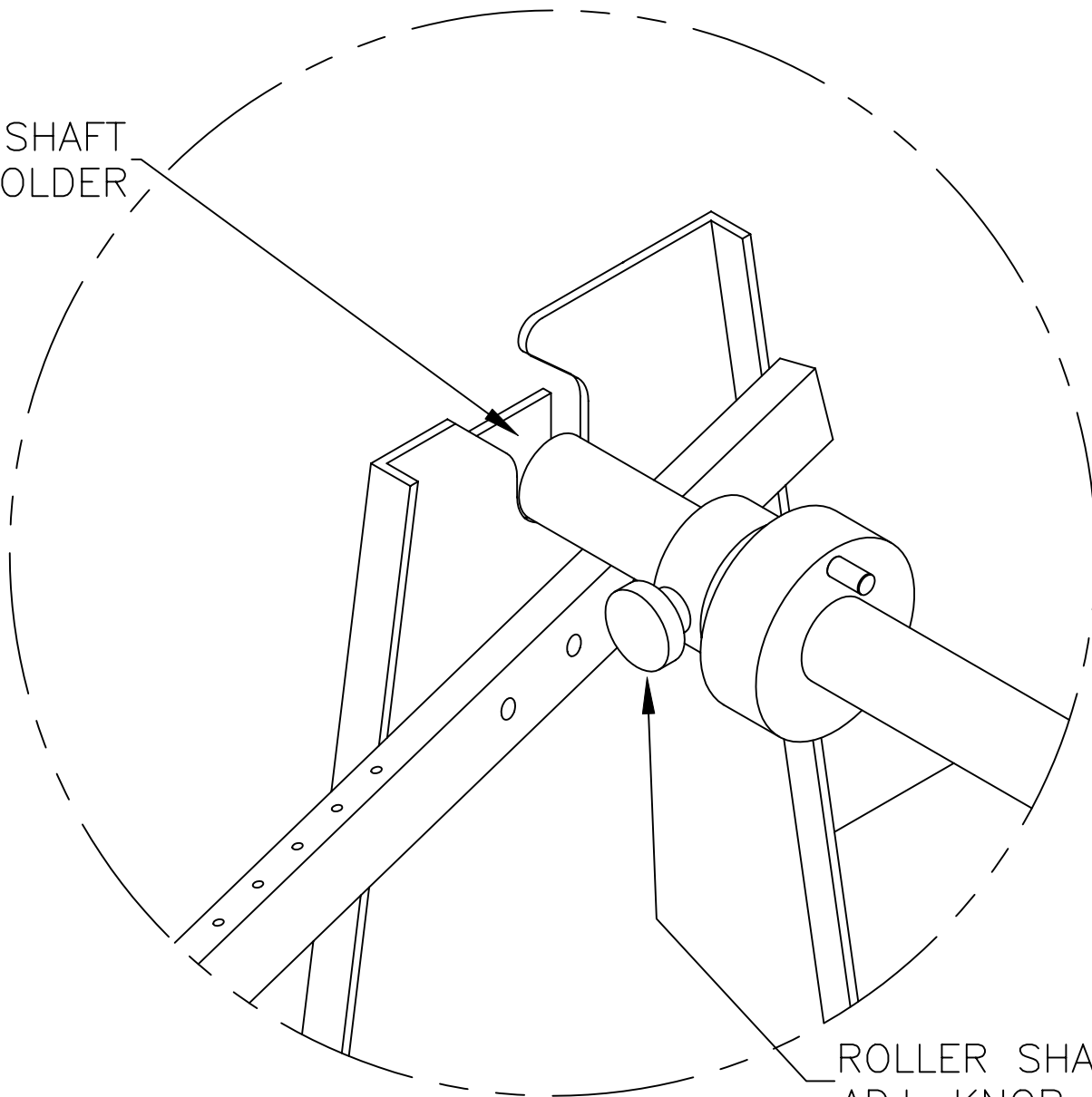

ROLLER SHAFT  
ADJ. KNOB

LEFT SIDE  
(BACK VIEW)

QUANTITY		-		FIGURE 2-8	
MATERIAL		-		 <b>Advanced Poly Packaging Inc.</b> <small>1331 Ewitt Road ■ Akron ■ Ohio 44306          Phone: 330-789-4900 ■ Fax: 330-789-4010</small>	
FINISH		-			
TOLERANCES UNLESS OTHERWISE NOTED: +/- .015 ON FRACTIONAL DIMENSIONS +/- .010 ON TWO PLACE DECIMAL DIMENSIONS +/- .003 ON THREE PLACE DECIMAL DIMENSIONS 125 ✓ ON MACHINED SURFACES ALL DIMENSIONS ARE IN INCHES PART MUST BE FREE OF BURRS AND SHARP EDGES				TYPE EQUIPMENT <b>T-1000</b>	
				B/M REF. NO.      PART NO. -	
				SCALE      DRAWN BY      APPROVED <b>1:1</b> NAME MELODY      NAME DATE      12/04/01      DATE	
NOTICE: THIS DOCUMENT CONTAINS PROPRIETARY INFORMATION AND IT SHALL NOT BE USED OR REPRODUCED OR ITS CONTENT DISCLOSED, IN WHOLE OR PART, WITHOUT THE PRIOR WRITTEN CONSENT OF ADVANCED POLY-PACKAGING INC.				TITLE      DRAWING NO.      REV. <b>ROLLER SHAFT</b> <b>TP-2-8</b> -	



## 2.7 Cycle Operation of the T-1000

If all prior installation procedures have been performed properly, the T-1000 should be in its operating location with air and power connected. All guards, funnels and covers should be in position and securely fastened.

Locate the foot switch and plug the foot switch in the rear foot switch connector (Fig. 2-5). Press the foot switch to index one bag through the "nip" rollers. One bag should index, blow open and stop between the pressure bar and the heater bar. If the T-1000 is not up to temperature, the machine will not cycle unless the <Pause> button is pressed.

If the web of bags breaks prematurely, further adjustments will be required. See Chapter 7, Trouble shooting. If one bag indexed through the machine, press the foot switch a few times more. Each previously indexed bag should detach completely from the web of bags. If the bag is not indexing and/or stopping or not tearing off properly, see Chapter 7, Trouble shooting.

*Note: Web of bags may track left or right for a few feet until "settled" on the web path. The roll of bags or the roller guides may require readjustment or realignment after the first few feet of bags are indexed.*

*Note: If bags were delivered with the T-1000 or the size of the bags were known to APPI, the T-1000 may be ready to run. Therefore, few changes to BAG SET UP may be required.*

## 2.8 Note on Adjustments to the T-1000

Upon receipt, it is not unusual for the T-1000 to be out of alignment due to shipping and excessive handling. Unless physically damaged, the T-1000 will function properly after minor adjustments are accomplished. Read Chapter 4 for information on adjustments of the T-1000.

## 2.9 Energy Conservation & Component Saver

The T-1000 is programmed to automatically shut down components after various periods of nonuse to preserve components and conserve energy.

**Motor shut off:** After two minutes of nonuse (or the amount of time set in the Technical Assistance / Timers screen), the motor will stop. To resume packaging, press the foot switch or other input signal. When the foot switch is pressed, the motor immediately runs, the bag in position is sealed, torn off and another bag indexed into position.

**Touch Screen shut off:** The touch screen backlight will shut off after 60 minutes of nonuse, preserving the life of the LCD and back light. To turn the screen back on, touch the screen.

**Heater bar shut off:** After 40 minutes of nonuse (or the amount of time set in the Technical Assistance / Timers Screen), electrical current to the heater bar cartridge will stop. To resume packaging, press the <START> key. You may have to wait until the heater bar is up to temperature depending upon the temperature of the bar.

**Air shut off:** 10 minutes after the heater bar current has shut down, air will be shut off disconnecting air flow to the blower. To resume packaging, press the <START> key.



# Operation Guide

---

## Chapter 3, Touch Screen Operation

Touch Screen Part Names

Specifications

Contrast Adjustment

Touch Screen Program

### 3. Touch Screen Operation

This section describes in detail, the identification, operation and adjustments of the Touch Screen Program.

#### 3.1 Touch Screen Part Names - Front Panel (See Fig. 1)

- 1 System Button (See Section 3.4)
- 2 F1 (Help Screen)
- 3 F2 Increase Brightness (when system button is pressed)
- 4 F3 Midpoint Brightness (when system button is pressed)
- 5 F4 Decrease Brightness (when system button is pressed)
- 6 F5 Job Save / Recall
- 7 Red LED (Alarm): Lit if Touch Screen is locked. To turn off, press System Reset Button on the rear panel of the Touch Screen.
- 8 Green LED (Power): Lit when Touch Screen is turned on

#### 3.2 Touch Screen Part Names - Back Panel (See Fig. 2)

- 1 RS-232 Communication port to PLC
- 2 Programming (For APPI use only).
- 3 Power Supply: Power terminal for Touch Screen Operation.

#### 3.3 Touch Screen Specifications/Features

Power: 24 VDC (+/- 10%)

Operating Environment: 0-50 degrees C, 85% RH or less

Display: Color LCD

Resolution (W x H (dots)): 320 x 240

Display area (mm): 115.2 x 86.4 (5.7")

Backlight: CCFL

Backlight Hours: approx. 50,000

Life of touch panel: 1,000,000 touches or more

PLC connection: RS232

Number Characters: 40 char. x 30 lines max.

#### 3.4 Touch Screen Contrast Adjustment

The contrast of the LCD may be adjusted if the screen is difficult to read. To adjust the contract, press the <System> button located to the right side of the active touch screen area (See Fig. 2).

Then press the F2 button to increase brightness and the F4 button to decrease brightness. F3 will go to the midpoint position.

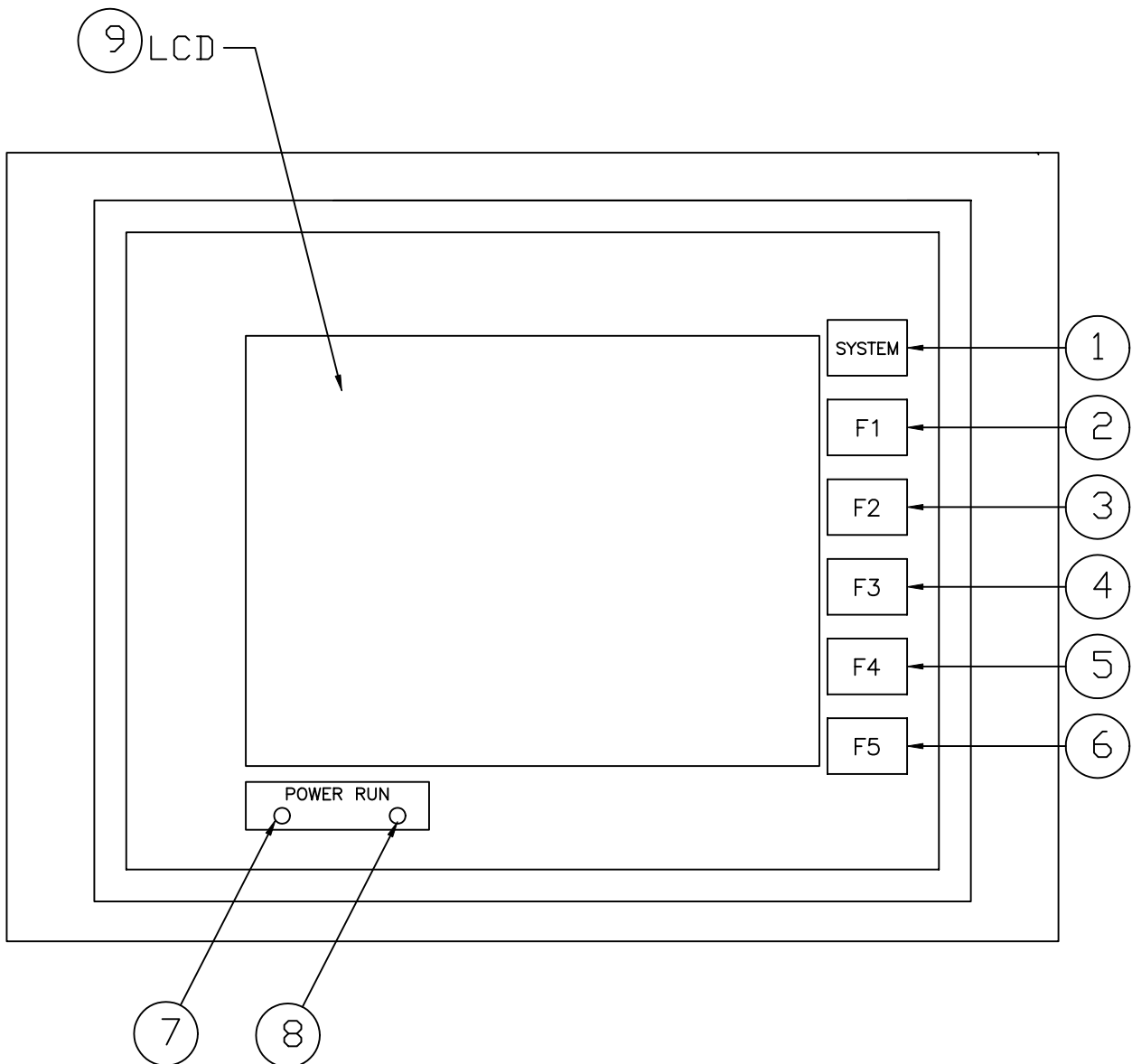

FIGURE 1



Advanced Poly Packaging Inc.

1331 Emmitt Road \* Akron \* Ohio 44306  
 Phone: 330-785-4000 \* Fax: 330-785-4010

TYPE EQUIPMENT T-1000	B/M REF. NO.	PART NO.
SCALE FULL	DRAWN BY NAME MELODY DATE 10/23/00	APPROVED NAME DATE

NOTICE: THIS DOCUMENT CONTAINS PROPRIETARY INFORMATION AND IT SHALL NOT BE USED OR REPRODUCED OR IT'S CONTENT DISCLOSED, IN WHOLE OR PART, WITHOUT THE PRIOR WRITTEN CONSENT OF ADVANCED POLY-PACKAGING INC.

TITLE I.O.P FRONT PANEL & LEDS DIAGRAMS	DRAWING NO. TP-T1G02	REV.
---	-------------------------	------

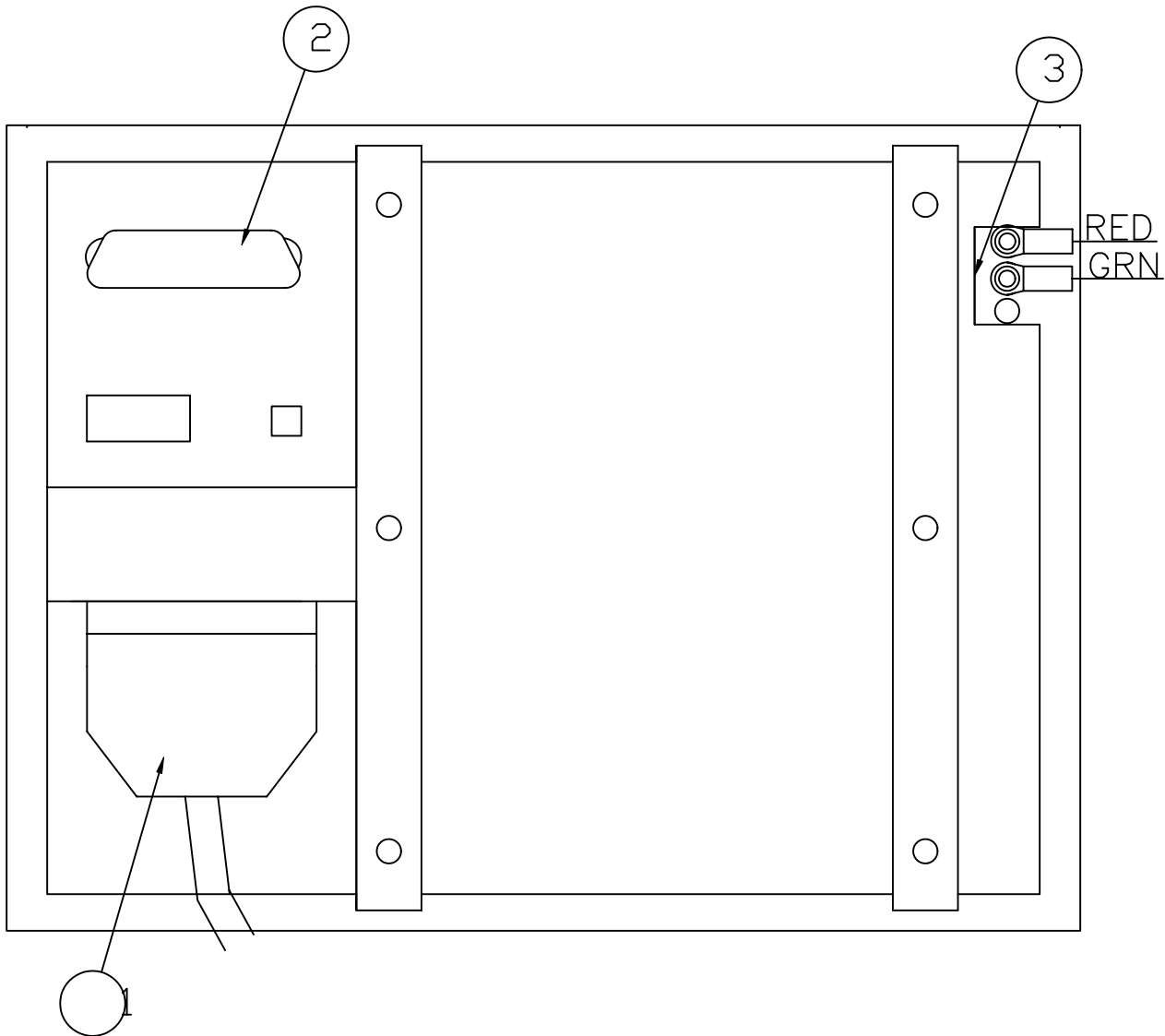

FIGURE 2



Advanced  
Poly Packaging Inc.

1331 Emmitt Road \* Akron \* Ohio 44306  
Phone: 330-785-4000 \* Fax: 330-785-4010

TYPE EQUIPMENT T-1000	B/M REF. NO.	PART NO.
SCALE FULL	DRAWN BY NAME MELODY DATE 10/23/00	APPROVED NAME DATE

NOTICE: THIS DOCUMENT CONTAINS PROPRIETARY INFORMATION AND IT SHALL NOT BE USED OR REPRODUCED OR IT'S CONTENT DISCLOSED, IN WHOLE OR PART, WITHOUT THE PRIOR WRITTEN CONSENT OF ADVANCED POLY-PACKAGING INC.

TITLE I.O.P REAR PANEL	DRAWING NO. TP-T1G03	REV.
------------------------------	-------------------------	------

### 3.5 Touch Screen Program

The Touch Screen Program is a "user-friendly" menu-driven setup and operation program. Popup windows are incorporated for quick and easy setting adjustments. Each time a setting is changed, the settings are saved so that if power is lost, the "job" will be recalled automatically without the need for reprogramming. Moving around through the program, entering menu levels and entering setup options are easily and quickly achieved by just one touch of the screen to set the options you choose. A general color scheme has been used for consistency with operation:

**Blue:** Background color. Blue is used as a background or text only color. Pressing this area will typically do nothing.

**Yellow:** Yellow buttons are Menu buttons which will take you to other available screens. Yellow buttons may be located anywhere on the screen.

**Green:** Setting button. Green buttons are used to change settings or mode of operation.

**Red:** Stop functions or warning messages.

### 3.6 Introductory Screen

When the T-1000 is turned on, an Introductory screen is displayed (Fig. 3-1). The Introduction screen is a welcome screen and has a button to take you to the Main Menu.

### 3.7 Main Menu

The Main Menu (Fig. 3-2) is the first menu screen displayed after the Introduction is flashed on the screen and allows you to go to all screens available in the T-1000. Nine options are displayed on the Main Menu which control the operation of the T-1000: 1) Bag Set Up Menu, 2) Auxiliary Menu, 3) Intro Screen Menu, 4) Counters Menu, 5) Graphs Menu, 6) Technical Assistance Menu, 7) Options Menu, 8) Job Save Menu, 9) UF-5000 Menu. These nine options are fully described in the following sections. Above the yellow menu buttons is the "top line buttons" which are displayed on most screens through the touch screen program:

**Start / Stop:** Toggle button controls operation mode; mode which enables T-1000 to cycle.

**Manual/Auto:** Toggle button to enter Automatic (paced rate) or Auxiliary Cycle mode.

**Pause/Setup:** Temporarily deactivates Predetermining Counter and Totalizing Counter until reset. Temporarily deactivates signal to auxiliary equipment. Allows cycle operation when heater bar is not up to temperature.

**Ready / Waiting:** Indicator LED. Displays

Ready when heater bar is at the temperature set point. Waiting flashes when the machine is not at temperature.



Fig. 3-1

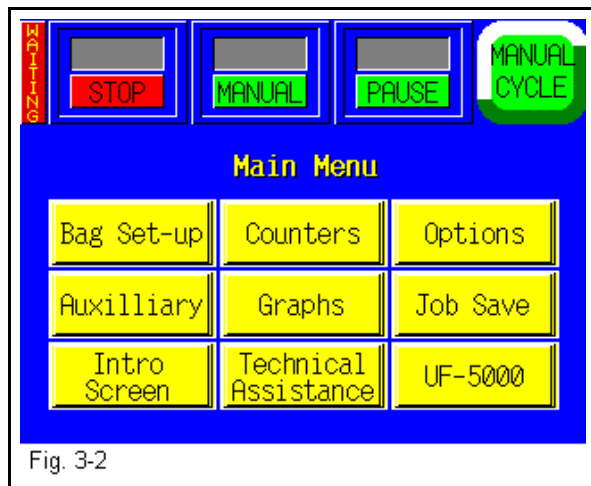

Fig. 3-2

### 3.8 Bag Setup Menu

The Bag Set Up Menu prompts the operator to input bag timer settings which change seal point, temperature, fill time (paced rate) and air pulse time. Bag thickness, length, width and product characteristics affect these settings. Once set, the operator may save the bag settings along with options settings and auxiliary settings for later recall (Fig. 3-3).

The bag set up menu is the menu where most entries and machine operation setting will occur. When a new bag size or thickness is introduced, the T-1000 must be *set up* to properly run the bags.

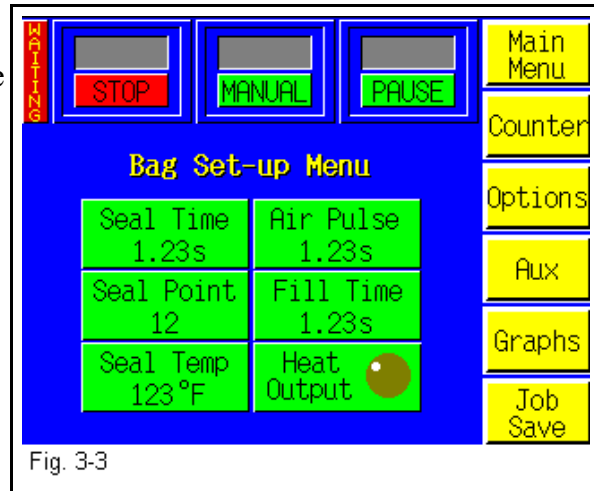

Fig. 3-3

### 3.9 Seal Time

Displays, in seconds, the time the pressure (rubber) bar will remain touching the surface of the bag for proper sealing. Sometimes referred to as "dwell time", seal time is one of three critical components to obtain a strong seal (other critical factors include seal temperature and seal pressure). To adjust the Seal Time value, touch the highlighted <Seal Time> menu option to display a number pad. To change the setting, press the number (decimal point first, if less than 1) and then press <Enter>. To clear an incorrectly pressed value, press the highlighted <Clear> button and retype the correct value. Pressing <Enter> will return you to the Bag Setup Screen. Test and further adjust if necessary. See Fig. 3-34.

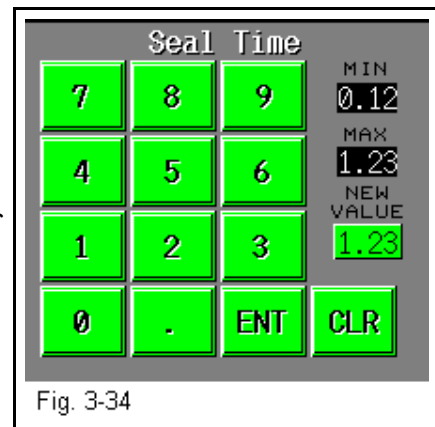

Fig. 3-34

### 3.10 Seal Temperature

When the power is ON, the heater bar element receives electrical current. The PLC pulses electrical current to the element until the temperature setting is reached. Shorter pulses indicate maintaining the temperature. An amber indicator lamp illuminates on the Bag Setup Screen while the element is receiving current. The longer the light is illuminating, the longer the "pulse" of current and the further away from the temperature setting. If the temperature of the heater bar is not within 10% of the set point, "Waiting" will be flashed on the top left screen. To adjust the value, press the highlighted <Seal Temp> button to display the number keypad popup screen. Enter the value and press <Enter> to return to the Bag Setup Menu. See Fig. 3-33.

*NOTE: After making adjustments, test the seal strength prior to beginning production. It is normal for the indicator light to illuminate (pulse) during operation. As the actual temperature approaches the set temperature, the pulses will get shorter and shorter. When the heater bar is up to temperature, the Waiting LED indicator*

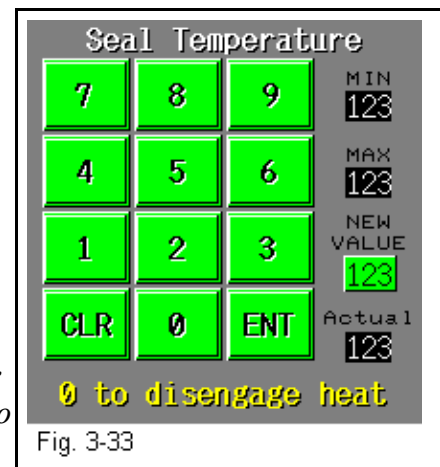

Fig. 3-33

will change to Ready. From a "cold" start, it takes approximately four minutes to reach the set temperature.

### 3.11 Seal Point

Seal point is a reference point. Increasing this number raising the seal point on the bag. Each increment adjusts the position approximately 1/8" up or down. To adjust the value, press the button labeled <Seal Point> from the Bag Setup Menu. Using the displayed number keypad, press in the value for the amount desired followed by the <Enter> button. Press the foot switch to test the setting and adjust as required. The proper positioning of the seal on the bag varies due to bag size and product characteristics. Wider bags generally require greater sealing area than do narrower bags. Additionally, bags packaged with bulky products require greater sealing area than do bags packaged with thinner products. See Fig. 3-32.

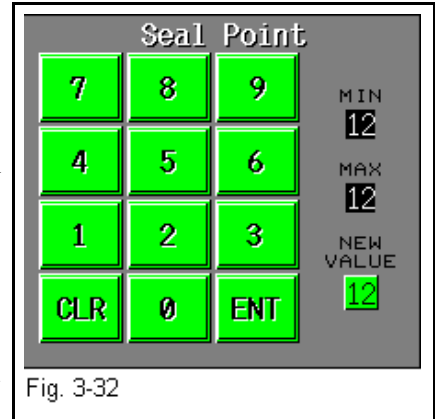

Fig. 3-32

### 3.12 Note on Seal Quality

Quality seals are achieved by making adjustments to SEAL TIME, SEAL TEMP., SEAL POINT and by having the proper seal pressure. *Note: Ensure Regulator Pressure is set to 80 PSI.* If, after making necessary adjustments, seal quality remains insufficient, additional options may be purchased to enhance seal appearance, integrity or strength. (See Chapter 1 for description of available options: FS-10 Flat Seal Assembly, TS-10 Trim Seal Assembly, BD-10 Bag Deflator, LS-10 Load Shelf, Twin Seal option). Wider seal bars are also available to increase the consistency of seals.

### 3.13 Air Pulse

Displays, in seconds, the amount of time that a burst of air will last, *initially* blowing the bag open. Wider bags and heavier gauge bags require a longer burst of air to initially open the bag. Narrower and thinner gauge bags require less air to initially open the bag. To adjust the value, press the <Air Pulse> button from the Bag Setup Menu to display the number keypad. Press the numbers on the keypad followed by the <Enter> button to return the Bag Setup Menu. See Fig. 3-33. Additionally, to increase the *volume* of air from the air pulse tubes, turn the Air Pulse valve (Fig 3-10) counter-clockwise; turning the valve clockwise will decrease the volume of air.

*Note: The volume of air set should be the minimum amount and duration required to open the bag.*

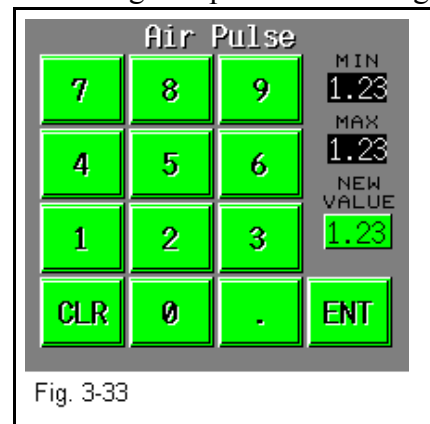

Fig. 3-33

### 3.14 Blower

Once the bag is initially blown open, the bag opening must be maintained while the product is being loaded into the bag. The BLOWER (Air Knife) provides a steady, adjustable volume of air into the bag. The blower shuts off momentarily when the foot switch is pressed to allow the bag to deflate during the seal operation. The blower reinitiates when the next bag is indexed into position. To increase the volume of air flow, turn the BLOWER flow valve (Fig. 3-10) counter-clockwise. To decrease the volume of air flow, turn the BLOWER flow valve clockwise.

### 3.15 Fill Time

The <Fill Time> button functions differently dependent upon the MODE in which the T-1000 is operating: 1) MANUAL, 2) AUTOMATIC (<AUTO>) mode or AUXILIARY mode.

1) In the Manual mode with NO accumulating funnel, Fill Time will do nothing. However, when the T-1000 is equipped with an accumulating funnel, Fill Time will affect the delay time before sealing, after the door has closed on the accumulating funnel.

2) In the AUTO cycle mode with no auxiliary infeed equipment, Fill Time affects the paced rate operation. The bagger will automatically cycle with the Fill Time delaying the seal bar after the bag has been blown open. In the AUTO mode, no foot switch or other actuator is used.

*CAUTION: To avoid physical harm, DO NOT cycle the T-1000 in the AUTOMATIC mode when funnel(s), guard(s) or covers are removed. Caution: Since the seal bar actuates automatically, operators must keep fingers, hands and other parts of the body well away from the sealing mechanism and all other moving parts at all times.* AUXILIARY cycle mode, FILL TIME displays, in seconds, the time for which a product, automatically filled by auxiliary equipment, has to be completely settled in the bag before the seal bar is actuated. This time is typically referred to as the DELAY TIME.

*CAUTION: To avoid physical harm, DO NOT cycle the T-1000 in the AUXILIARY mode without the funnel(s), funnel extension(s), guard(s) and covers in proper position. Since the seal bar actuates automatically, operators must keep fingers, hands and other parts of the body well away from the sealing mechanism and all other moving parts at all times. See Fig. 3-34.*

To adjust the value, press the highlighted <Fill Time> button to display the number keypad. Then enter the value on the number keypad followed by the <Enter> button to return to the Bag Setup Screen.

*NOTE: Auxiliary mode is further described in Appendix B, if Auxiliary options or components were provided by APPI.*

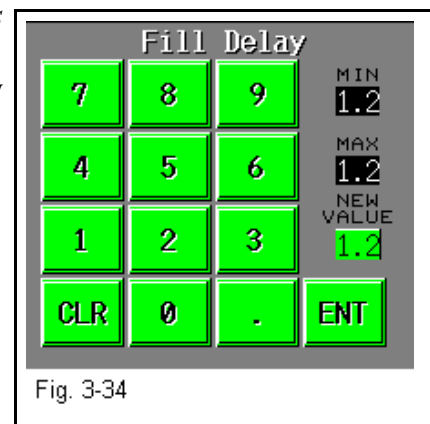



# RIGHT PANEL

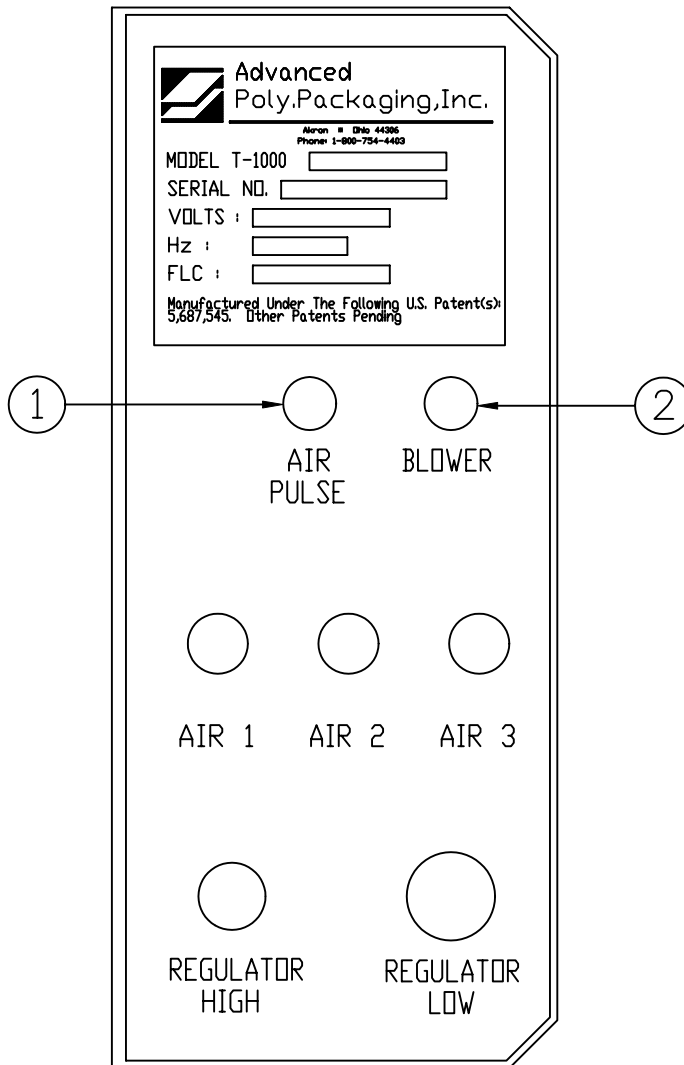

FIGURE 3-10



Advanced Poly Packaging Inc.

1331 Emmitt Road • Akron • Ohio 44306  
 Phone: 330-785-4000 • Fax: 330-785-4010

TYPE EQUIPMENT T-1000	B/M REF. NO.	PART NO.
SCALE 1:1 1/4	DRAWN BY NAME MELODY DATE 10/24/00	APPROVED NAME DATE

NOTICE: THIS DOCUMENT CONTAINS PROPRIETARY INFORMATION AND IT SHALL NOT BE USED OR REPRODUCED OR ITS CONTENT DISCLOSED, IN WHOLE OR PART, WITHOUT THE PRIOR WRITTEN CONSENT OF ADVANCED POLY-PACKAGING INC.

TITLE  
PNEUMATICS BACK PLATE

DRAWING NO.  
TP-T1E02

REV.

### 3.16 Counters Menu

The T-1000 is equipped with three internal counters as a standard feature. See Fig. 3-4.

**Totalizing Counter:** To track production, use the Totalizing Counter to count cycle operations of the T-1000. To turn this option ON, press the <Total Count> button (the button will darken indicating that the option is ON). Press the <Reset> button to reset the counter to zero.

**Predetermining Counter:** To halt production after a preset number of cycle operations, use the Predetermining Counter. When the final count has been reached, a message screen will be displayed. Set the value by pressing the <Set> button and then type the value on the number keypad followed by the <Enter> button. When turned ON, the button will be darkened. *Note: To reset the value or change the value, the option must be turned OFF.*

**Continuous Strip Counter:** To disable the tear off feature and package in a continuous strip of bags, use the Continuous Strip Counter. The <Set Value> button is used to set the number of bags in the strip. If no preset number is desired, set the value to zero and the continuous strip feature will continue to operate without tearing off bags. When turned ON, the button will be darkened.

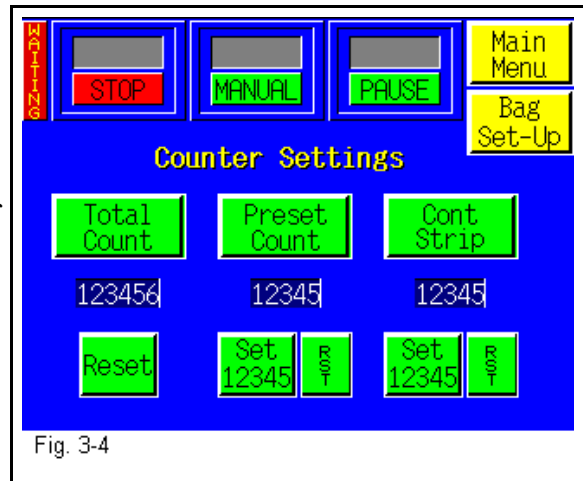

Fig. 3-4

### 3.17 Options Menu

Options that have been added to the T-1000 at the factory can be setup from the Options Screen (Fig. 3-5). If options were not installed at the factory, then N/A (Not available) will be displayed to the left of each options button. Otherwise, the button will display ON or OFF.

If the option is not available, you may press the button for a description of the option's use.

Note: If options are added in the field, a pass code is required to Enable use of the option. Contact APPI for pass codes. Options which have been purchased separately must be installed by APPI or by qualified maintenance personnel.

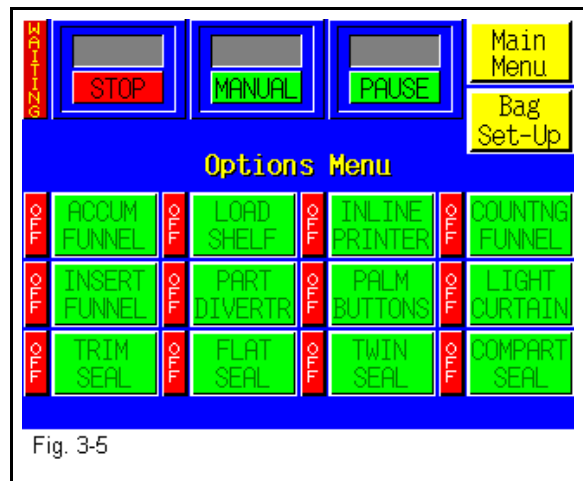

Fig. 3-5

The following sections describe how to setup optional equipment on the T-1000. If your T-1000 is not equipped with these options, please disregard these sections.

### 3.18 Accumulating Funnel

The Accumulating Funnel Option is not included in the standard T-1000 package and must be purchased separately. This special purpose funnel has several functions: 1) to collect (accumulate) a product before dropping the full contents of the Accumulator into the bag, 2) to contain a product while the bagger is in a CYCLE operation (sealing, tearing off, and indexing a bag into position), 3) to insert the funnel into the bag and keep the product away from the sealing portion of the bag (Insert Funnel) and 4) to physically open the bag with a gate that enters into the bag while the product exits the funnel.

Increased production can be achieved in manual load or automatic load operations. In a manual operation, the operator can insert the product into the funnel without waiting for the bag to be in position and opened. When the bagger is ready to receive the product, the door at the bottom of the funnel will open, drop the product and shut, to allow the funnel to again be loaded.

In an automatic operation, increased production can be achieved by allowing counters, fillers, scales and other infeed equipment to feed the funnel without regard for the status of the bagger.

Additionally, the funnel can be operated in an "Open Accumulator" mode or a "Closed Accumulator" mode. In an Open Accumulator mode, the door is closed only during the CYCLE operation. When the door opens (when the bag is in position and blown open), the door will open and remain open until the bag has been filled with the required amount of product. The door will then close only until the next bag is in the Closed Accumulator mode, the door remains closed until the full contents have been inserted into the funnel. When the bag contents is reached in the funnel, the door will open and all of the product will enter the bag in one. The Setup screen displays the time, in seconds, which the bagger will wait after the door opens (product dumps). To increase or decrease the delay time, press <DELAY TIME> button and the key pad will appear, press in the value, then when finished <ENTER>. See Fig.3-21. The function of the Accumulating Funnel: Open, Closed or Insert Funnel can be set in the AF-10 Setting Screen.

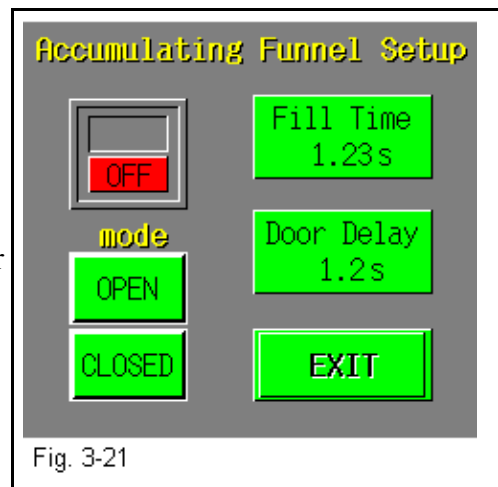

### 3.19 Load Shelf

This option is used as a support shelf for the product to avoid the bag from prematurely tearing off at the perforation when the product is inserted in the bag. The Load Shelf allows the product to drop onto the shelf relieving the pressure on the bottom of the bag.

To turn ON the load shelf, press the <Load Shelf> menu option and press the <ON> button. The Load Shelf delay time is the length of time the shelf is in the down position. Increase the time for longer bags. See Fig. 3-27.

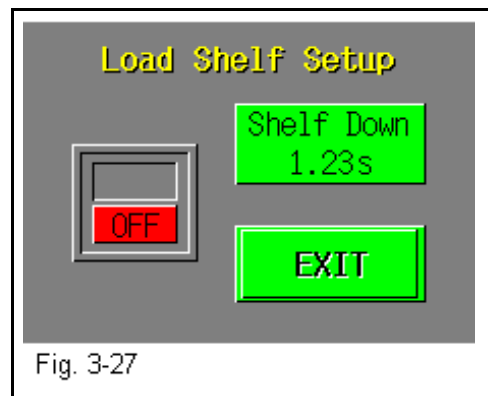

## 3.20 Inline Printer

A Printer option is not included in the standard T-1000 package and must be purchased separately. Used for product identification, a Printer option prints information, graphic images or bar codes directly to the surface of the film.

APPI offers two printers as an option: 1) Thermal Inline Transfer Printer - prints text, graphics and bar codes, formatted in a separate software program. The label formats, saved in a database structure can be recalled and "downloaded" to the printer. 2) Hot Stamp Printer - prints text (part numbers, date codes, lot numbers, etc.). Individual characters are placed onto a "grooved plate" which, when heated will transfer the ink (ribbon) directly onto the bag. Also, magnetic plates are offered.

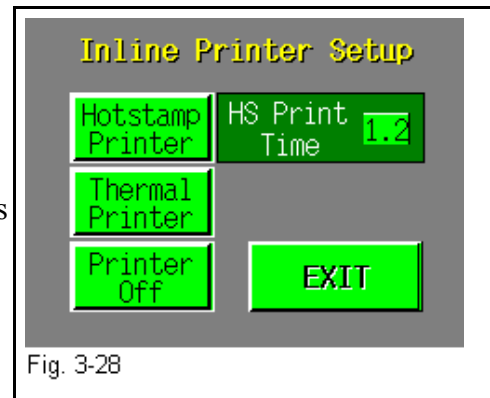

Both the Thermal and Hot Stamp printers use ribbon (foil) to transfer ink to the surface of the bag. To enable Printer operation on the Thermal Transfer (TT) Printer, press the highlighted Printer button.

Press the highlighted Hot Stamp (HS) Printer button to enable operation of that Printer and press Printer Off to disable the operation of the printer. See Fig. 3-28.

If the HS Printer button is pressed, a secondary setup screen will automatically appear for further settings. To enhance text/graphics print quality, adjust the Print Time (time, in seconds that the ribbon will be *stamped* on the bag) until required print quality is met. Press <EXIT> when finished.

## 3.21 Counting Funnel

The Counting Funnel option is not included in the standard T-1000 package and must be purchased separately. Used to count products entering the bag, the counting funnel may operate in conjunction with the Accumulating Funnel to load a predetermined number of a product into the bag, manually fed or automatically fed. Products fed into the funnel from a vibratory bowl or infeed conveyor can be counted while entering the bag or while being collected in the accumulating funnel. Various infrared "eyes" are available which will "see" even the smallest of parts. The Eye typically mounts to the top of the funnel seeing the product as it enters the funnel. Once the preset count is reached, the product is loaded and the bag is sealed and torn off automatically. Once another bag is in position, the Eye continues to detect product entering the bag or funnel.

To turn the Counting Funnel ON, press the <Count Funnel> menu option to bring up the Counting Funnel Setup screen. The Fill Delay setting is the amount of time between the point the final count is reached and the bagger begins the seal operation. To adjust the Fill Delay value, press the <Fill Delay> button, then use the key pad to type in the number of parts to be counted. Set the value of parts to be counted by pressing the <Count Value> button. See Fig. 3-22.

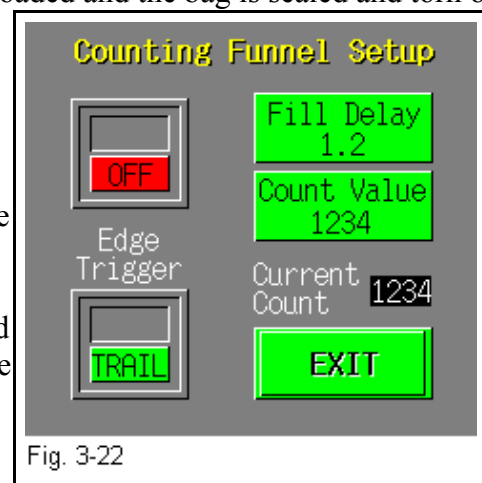

To count the product when it first enters the *detection field*, choose the LEADING EDGE option. To count the product when it exits the *detection field*, choose the TRAILING EDGE option. The LEADING EDGE setting is typically used for shorter components in an automatic operation whereas the TRAILING EDGE setting is used for components that are longer or that vary in length. Press <EXIT> to return to the Options Menu.

### 3.22 Insert Funnel

The Insert Funnel option (IF-10) is used for flowing products whereas the product may contaminate the sealing area or when air flow to bag must be turned off during bag filling. The funnel enters the bag and remains in the bag until signaled with a foot switch or automatically by a filler.

To turn the Insert Funnel ON, press the toggle button. To disable the air, press the Air Delay, type in the amount of time the funnel is filling up the bag before the air should shut off. Fig. 3-25.

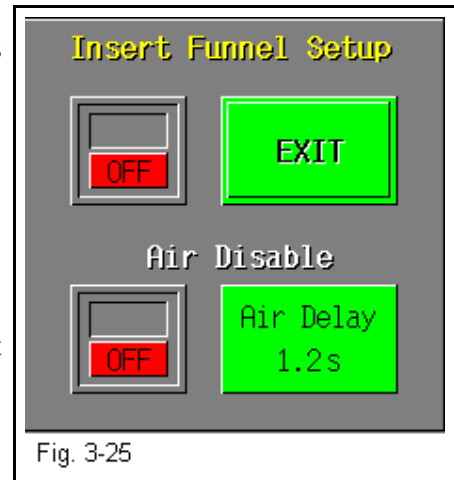

### 3.23 Diverting Funnel

The Diverting Funnel option (DF-10) is used to signal a diverting mechanism, located either beneath the seal bar of the T-1000 or at the end of a conveyor, to direct product one way or another (or into Box A or Box B) To turn the option ON, press the toggle button. Then set the value of bags (Part Count) that will be in each batch quantity. A delay time is also provided to allow the last bag in the count to clear the diverter before it cycles. To adjust the delay time, press the <Flip Delay> button, enter the value in the keypad and press <Enter>. Fig. 3-23.

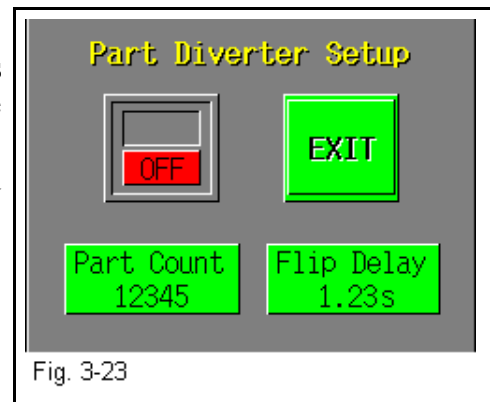

### 3.24 Palm Buttons

The Palm Buttons option (Dual Palm Buttons) is not included in the standard T-1000 package and must be purchased separately. This option is used as a safety device to avoid personal injury by ensuring that fingers or hands are not in the seal area during the cycle operation of the T-1000.

*Caution: To avoid personal injury, do not operate the T-1000 when funnels, guards or covers are removed. Advanced Poly-Packaging, Inc. recommends either the Palm Button or Light Screen options to safeguard operators.*

The Palm Button option operates in lieu of a foot switch. Two buttons, positioned on opposite (left and right) sides on the top of the T-1000 covers, must be *pressed* or *touched* simultaneously to cycle the bagger. If both buttons are not pressed at the same time, or if one of the buttons are held while the other button is pressed, the T-1000 will not cycle. As an additional safety function, the Automatic cycle mode is disabled when the Palm Button option is turned ON. The foot switch input is also disabled when the Palm Button option is turned ON. To turn ON this option, press the <Palm Button> menu option and press the toggle ON button.

### 3.25 Light Curtain

The light curtain option is offered as a safety device and also to increase production by providing “hands-off” product loading. Additionally, a message screen can be toggled ON to display a message when the curtain has an obstruction in the field. See Fig. 3-35.

When the T-1000 is first turned on, the Light Curtain must reset by pressing a Reset Button position in the Touch Screen housing. A green LED will then be displayed on the light curtain emitter.



Fig. 3-35

A minimum ON timer is provided so that false signals do not cycle the bagger when the Auto Cycle option is turned ON. Additionally, a Load Time delay is provided which delays the T-1000 from cycling immediately after the light curtain field obstruction is removed. See Fig. 3-26.

### 3.26 Trim Seal

The Trim Seal option is not included in the standard T-1000 package and must be purchased separately. Used to enhance the appearance of packaged products, the Trim Seal option removes the excess film (trim) from the bag, above the seal. The *Blow-off time* indicates the time, in seconds, which a blower will remove the excess film from the bag (trim-off time). The Trim Seal option is ideal for 1) retail products for enhanced appearance and 2) hanging products for reduction of "shelf" space.

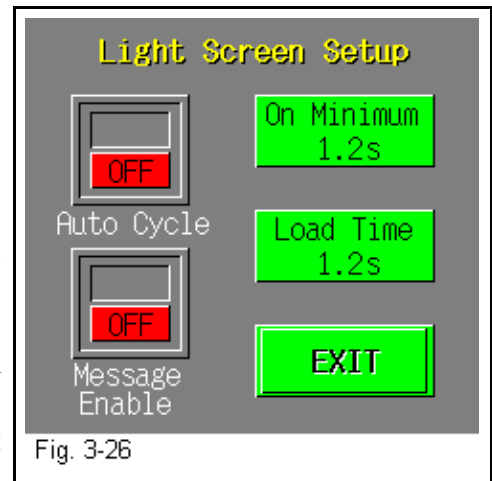

Fig. 3-26

*Note: To properly "trim-off" excess film, the bag length may have to be increased to provide the required finished bag size. We recommend trimming at least 1.5" of film from the bag.*

Press the ON/OFF toggle button to enable and disable the operation of the Trim Seal option. Press the value on the keypad to increase or decrease the Blow off Time value (trim-off time). Seal Point, Seal Time and Seal Temp. buttons are also available on this screen which are the same settings button that are on the Bag Setup Screen. Adjust all values until bags are trimming consistently. When finished and tested, press the <Exit> button to return to the Options Menu. See Fig. 3-29.

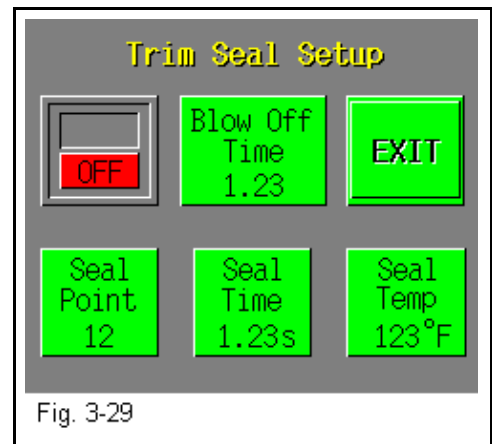

Fig. 3-29

### 3.27 Flat Seal Assembly

The Flat Seal Assembly option is not included in the standard T-1000 package and must be purchased separately. Used to help decrease or eliminate wrinkles or folds when sealed, the Flat Seal Assembly can easily be attached. For products which require a high integrity bag, for retail products, bulky products or "air tight" packages, the Flat Seal Assembly is ideal. The Flat Seal Assembly, also called "fingers", flattens the seal portion of the bag (two layers of poly) by pulling the sides of the bag away from the center. The fingers enter the bag immediately before the pressure bar presses the two layers of the bag together, against the front sealer plate.

Pulling on the sides of the bag outward causes the layers to flatten, decreasing the possibility of folds. To turn the Flat Seal Assembly ON, press the <Flat Seal> button on the Options menu and toggle ON the ON/OFF button. Use the <Setup> button to make it easier to mechanically adjust the fingers along the front plate slots on the T-1000. See Fig. 3-24. Once the mechanical adjustment is complete, press <ON> and <AUTO> for normal operation of the flat seal assembly. In the Auto mode, the fingers will automatically extend into the bag immediately prior to the pressure bar sealing the bag. When finished, press the <Exit> button to return to the Options menu.

### 3.28 Twin Seal

The Twin Seal™ option is not included with the standard T-1000 program package. This option is available and will place an additional seal approximately 3/4" from the initial seal. The product is sealed in the bag with two parallel seals approximately 3/4" apart. The Twin Seal™ option is a function of the program and requires no mechanical setup. The Twin Seal™ option is ideal for products which: 1) require an extended shelf life, 2) are medical products and require medical/pharmaceutical packaging, 3) are heavy or bulky and difficult to seal and 5) require high integrity seals. To turn on the Twin Seal™ option, press the <Twin Seal> menu option and toggle the option ON.

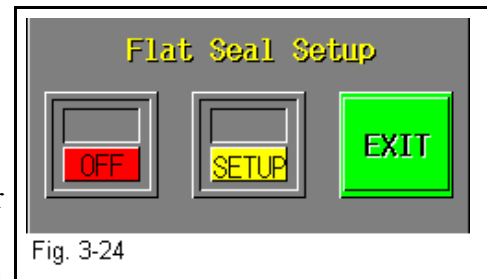

Fig. 3-24

*Note: You may need to decrease the Seal Point value on the Bag Setup Screen to allow space for two seals on the same bag.*

### 3.29 Compartment Seal

The Compartment Seal option is offered to allow for two different products in the same bag to be packaged, separated by a seal. For instance, it may be necessary to segregate a sharper object (screw) from a plastic component (mounting plate). Both seal points can be adjusted by the operator to increase or decrease the size of each compartment. However, the larger object should be placed into the bag first.

First set Seal Point 1 by pressing the <Seal Point 1> button and typing in the value on the number keypad. Adjust the first seal point until the desired location is achieved. Then, turn the option ON by toggling ON the ON/OFF button. Adjust the second seal point by pressing <Seal Point 2> and entering a value in the number keypad. Adjust the value of the second seal point until the desired position is achieved. Each seal time may be adjusted if you wish the Trim Seal after the second seal has been placed on the bag. See Fig. 3-35.

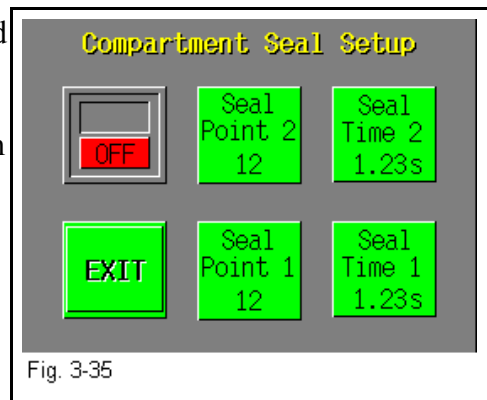

Fig. 3-35



### 3.30 Auxiliary Screen

The T-1000 Touch Screen Program is preprogrammed to accept almost all auxiliary equipment signals. Accepting the signals from other equipment so that the two or more pieces of equipment "talk" to each other is essential to a fully automatic packaging system. Rarely will reprogramming be necessary to interface auxiliary (infeed) equipment. Additional cabling, however will be required which will transfer the signals between the T-1000 and your existing equipment. Three auxiliary signals are provided with the T-1000 so that no additional modifications or wiring is required for the integration.

Once connected and with both systems running independently, turn the Auxiliary Signal ON by pressing the ON/OFF toggle button from the Auxiliary Screen. An output time delay is provided which delays the bagger from sealing after the auxiliary infeed signal has cycled and signaled the bagger to seal. To adjust the delay timer, press the <Output Delay> button and enter the value, in seconds, on the number keypad. See Fig. 3-6.

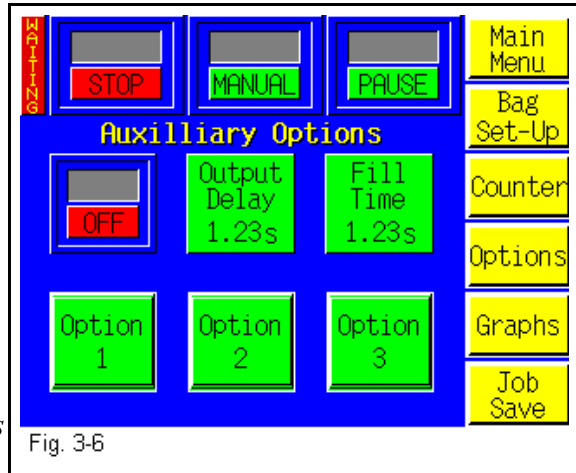

Fig. 3-6

*CAUTION: We recommend that APPI technicians provide the cable(s) linking the equipment.*

*Contact APPI customer support for information which will be required for the integration.*

When the Auxiliary setup procedures are complete, toggle the T-1000 from <Manual> to <AUTO> by pressing the <Manual/Auto> toggle button. This will place the T-1000 in the Automatic / Auxiliary mode.

### 3.31 Graphs Screen

Graphic production screens are provided to illustrate the number of cycles per minute, hour and average. Touch the graph for more information including the formula used to generate the data. Fig. 3-7.

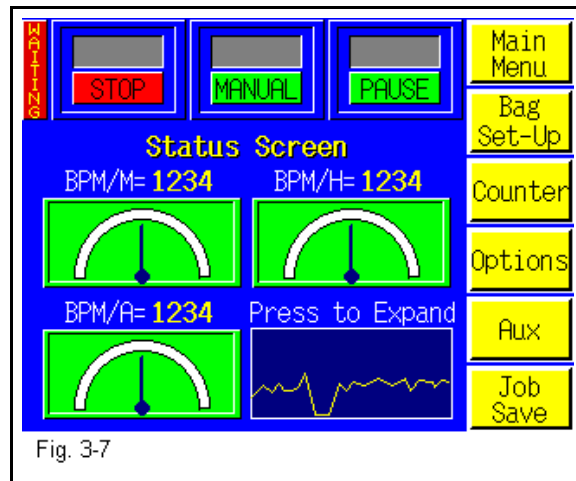

Fig. 3-7

A line graph is provided to illustrate production speeds for the past 36 hours of production. Touch the line graph to expand the graph and illustrate more detailed information. Fig. 3-8.

To reset the graph, press the <Reset> button. To reset the time also, press the <Reset> button twice.

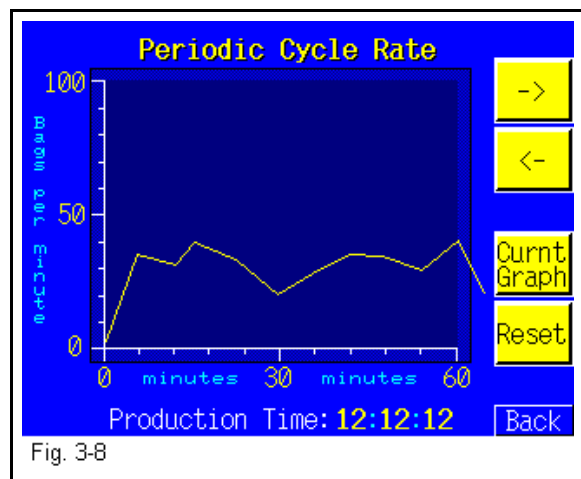

Fig. 3-8



The <Current Graph> button brings you back to the current hours production data. Press the < (arrow left) button to see past production hours.

Press the <Back> button to return to the Graph Status Screen.

### 3.32 Job Save / Recall

The T-1000 is able to store 32 machine settings, called *jobs*, including BAG SETTINGS, OPTIONS SETTINGS and AUXILIARY SETTINGS.

Each time a setting is changed on the T-1000, the settings are immediately saved in memory so that if power is lost, the T-1000 will power on with the job that was running before power was lost. JOB 32 setting is preset by APPI. JOB 32 is the factory settings which cannot be overwritten by the operator. To *save* a job, press the <JOB SAVE> menu option (Fig. 3-9) and then press the <Save> button located beneath the Job number you wish to save. After pressing the <Save> button, a Warning message is displayed that warns that you may overwrite a previously saved job. To bypass this screen, press the okay button.

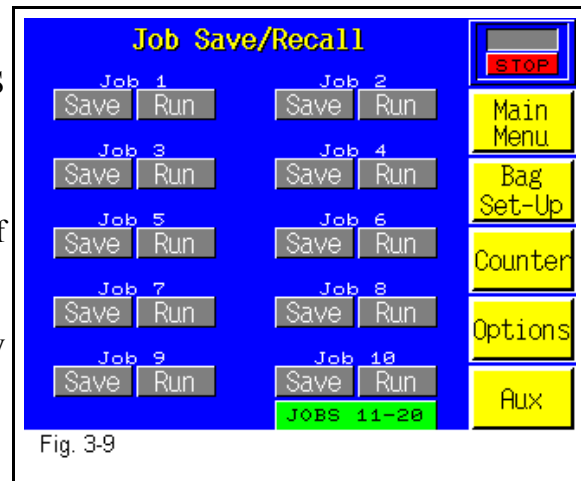

Fig. 3-9

To see the Default (Factory) Settings, press the <Info> menu option on Job 32. See Fig. 3-11

### 3.33 Technical Assistance

Press F1 or press the <Tech Assist> menu option from the Main Menu to obtain APPI phone number and determine Program Versions. See Fig. 3-12. Program Versions are required for telephone support from Advanced Poly-Packaging, Inc.

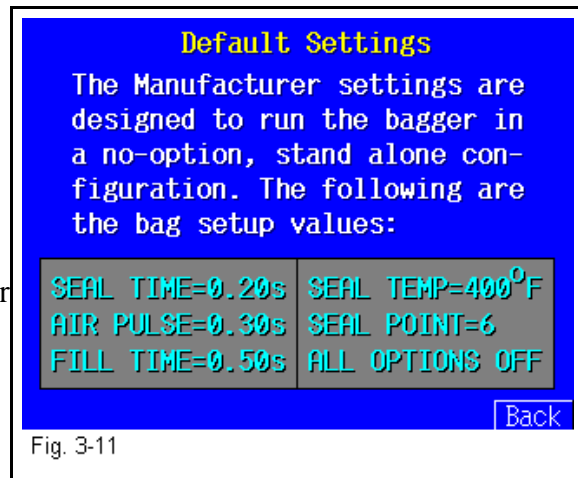

Fig. 3-11

Several menu options are available from the Tech Assist. menu which will assist with troubleshooting the T-1000.

### 3.34 Timers

The T-1000 is programmed to turn off components for energy conservation and to increase component life. Factory settings are described as suggested settings.

To increase the time of nonuse before the motor turns off, press the <Motor Off> button and type in the value on the number keypad. The motor turns on automatically when the machine is cycled.

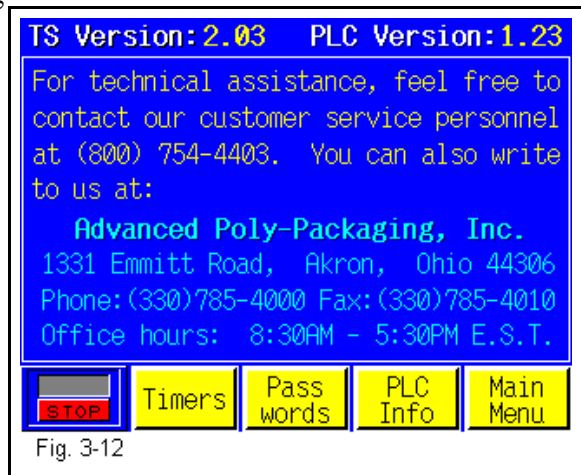

Fig. 3-12

Adjust the Heat Off timer to the amount of time greater than break or lunch periods up to 60 minutes. Press the <Heat Off> button and enter the new value in the number keypad. See Fig. 3-13.

*Note: It normally takes 3-4 minutes to bring the heater bar to temperature depending on the Seal Temp. value and the current temperature of the heater bar.*

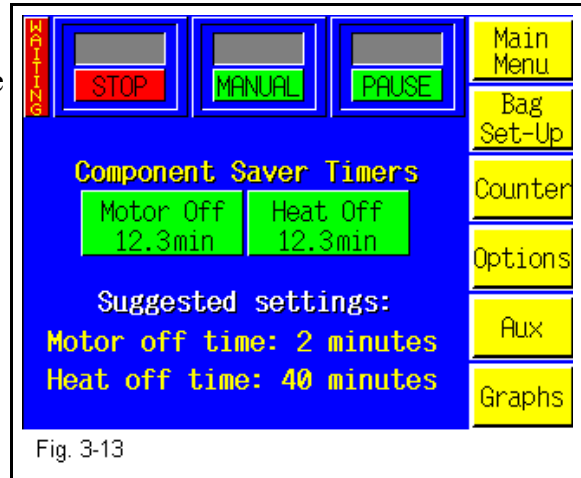

Fig. 3-13

### 3.35 Passwords

The Options Enable Screen is used at the factory to “enable” options for use by the operator. A status box is located to the left of the option to indicate if the option is available to operator. If OFF, the option settings screen will not be displayed for use by the operator. See Fig. 3-14.

Options must be purchased from Advanced Poly-Packaging, Inc. to obtain the pass code.

Contact Advanced Poly-Packaging, Inc. Service Dept. for more information regarding options available for the T-1000.

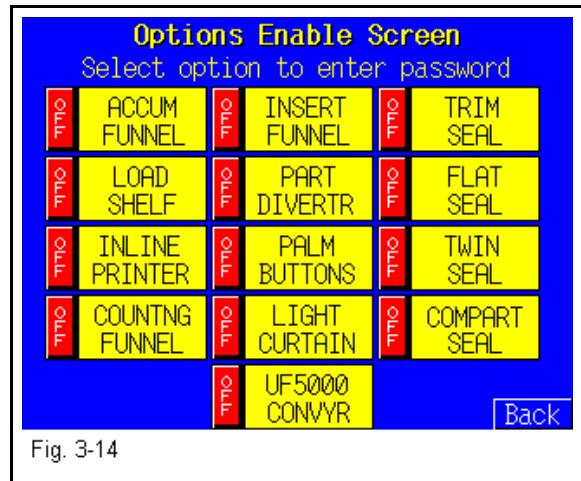

Fig. 3-14

### 3.36 Inputs / Outputs (PLC)

The PLC I/O screen is provided for maintenance personnel to determine the status of the PLC and review the mode of Outputs and Inputs. PLC I/O screen(s) are also used to assist APPI Service Technicians, working with your Maintenance Personnel to troubleshoot the T-1000 in the field. See Fig. 3-15.

To determine the function of each Input / Output, press the LED to display a brief description. See Fig. 3-30, 3-46 through 3-50.

The PLC I/O screen also provide the run Hours, Chart and Cycles counters. These counters cannot be reset by the operator.

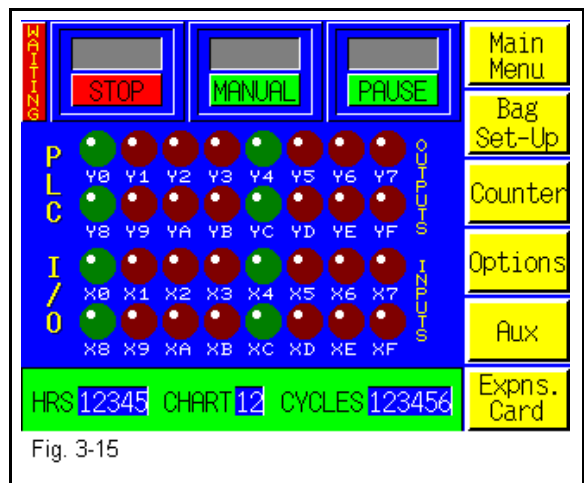

Fig. 3-15

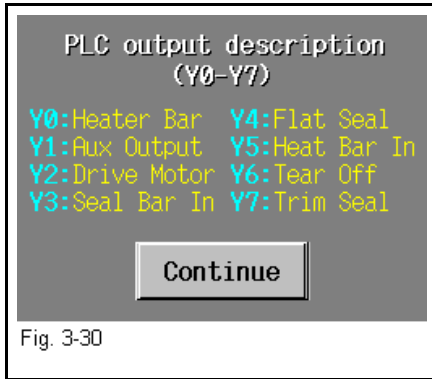

Fig. 3-30

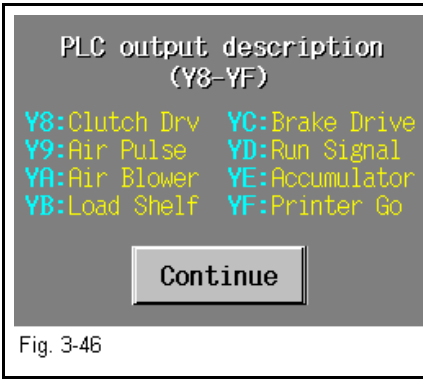

Fig. 3-46

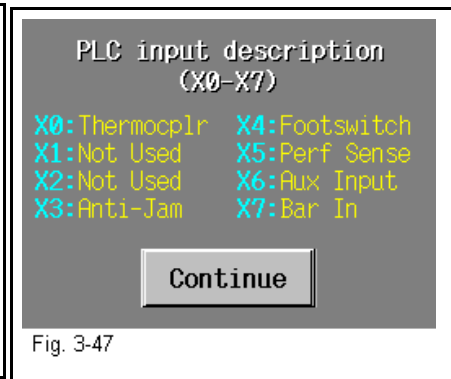

Fig. 3-47

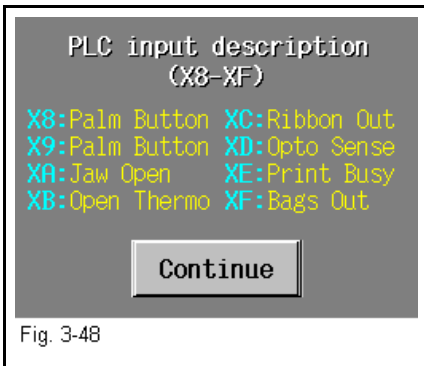

Fig. 3-48

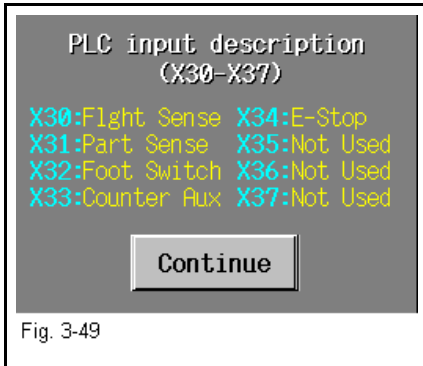

Fig. 3-49

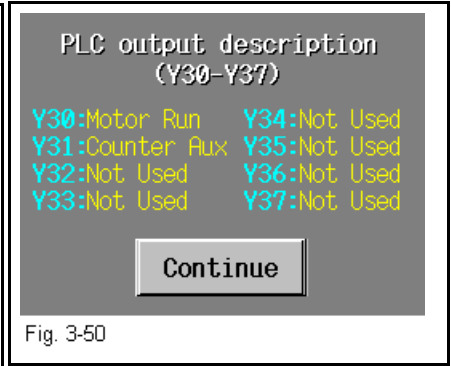

Fig. 3-50

### 3.37 Input / Outputs (Expansion Card)

Expansion PLC I/O card is installed only if auxiliary infeed equipment is provided with the T-1000, including the UF-5000 or US-5000. This screen is useful when trouble shooting the conveyor Inputs and Outputs.

To determine the function of each IO, press the LED to display an information screen describing the function. See Fig. 3-16.

### 3.38 UF-5000 Operation Screen

The T-1000 is programmed to also control the UF-5000 Infeed Conveyor if equipped with the Expansion PLC Card. This screen allows the operator to setup the conveyor to run standalone, with the T-1000 or with parts counters.

CONV CYCLE button manually cycles the conveyor and also toggles OFF auxiliary mode buttons.

SETUP/RUN button toggles ON the conveyor to RUN with the T-1000.

ON/OFF Bagger Auxiliary button sets up the communication with T-1000.

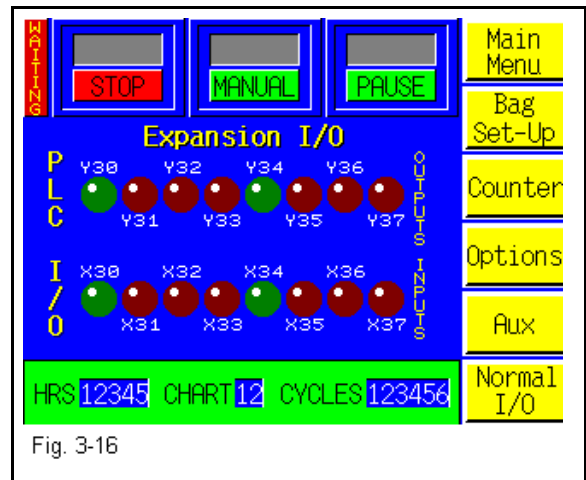

Fig. 3-16

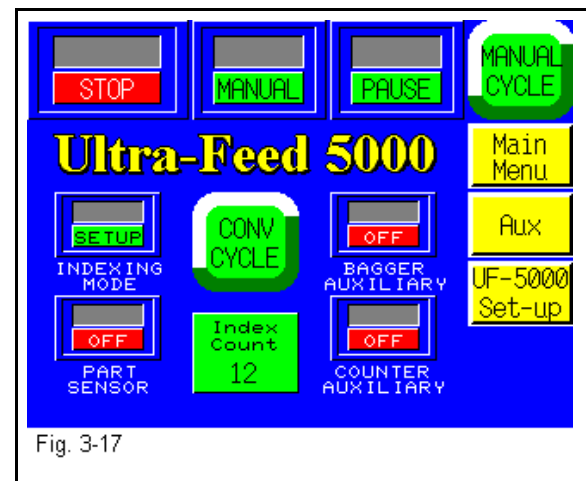

Fig. 3-17

ON/OFF Counter Auxiliary button sets up the communication with counters (UC-2400).

turns on photo eyes mounted in the discharge funnel of the UF-5000 (CE-10) option, if equipped.

Index Count value is the number of compartments that will be indexed before providing an output signal. See Fig. 3-17.

### 3.39 UF-5000 Settings Screen

The UF-5000 settings screen provides all the settings to control production speeds and timing of the integration components of a system.

Fill Time is the amount of time from the time the conveyor cycles to the point that the bagger cycles. See Fig. 3-18.

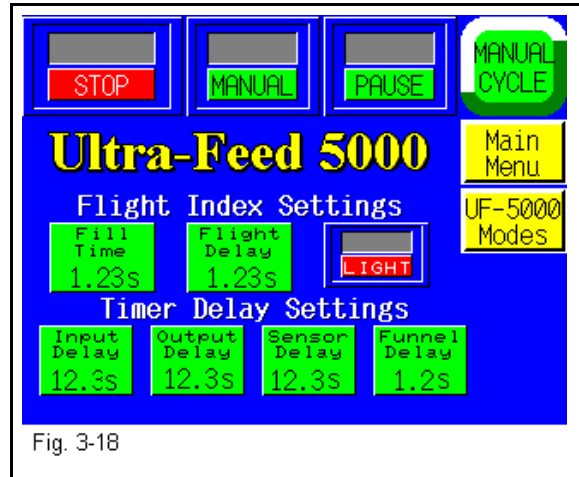

Flight Delay is the delay time that the flight sensor is active when the flight (cleat) passes through the optical eye (normally set a .2 sec.).

Light/Dark setting is determined by the type of sensor used to detect the cleats (typically set at Light).

Input Delay is the amount of time from the point the conveyor receives a signal to index to time that conveyor indexes.

Output Delay is the amount of time after the conveyor indexes to the point that the conveyor signals the bagger that it has cycled.

Sensor Delay is the amount of time after the conveyor indexes that the photo eyes (CE-10 option) “looks” for a parts before indexing another compartment of the conveyor.

Funnel Delay is the amount of time after the conveyor indexes to the point that an accumulating funnel (AF-10 option) cycles (if equipped).

Adjust each timer by pressing the associated timer and entering the value on the number keypad. After each value, test the settings by cycling the conveyor. Press the UF-5000 Mode button to return to the UF-5000 Operation Screen.

### 3.40 Information Screens

The T-1000 touch screen program provides for many informational screens that provides descriptions of functions or screens. See Fig. 3-19 for an example of an information screen.

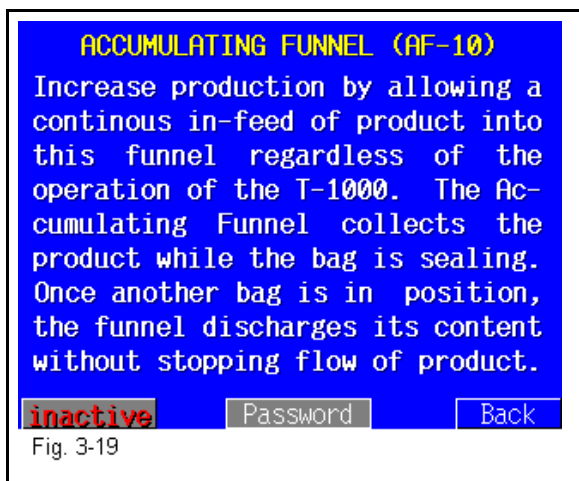

### 3.41 Message Screens

Message screens provide functional messages that describe errors or the status of equipment.

Fig. 3-20 is an example of a message screen. Other message screens include: Open Frame, Printer Fault, Open Thermocouple, Job Run Error, Out of Bags, Predetermined Count Reached, Perf Sensor not Activated, Light Curtain Reset, Seal Bar not Engaging, UF-5000 Estop Engaged, UF-5000 Password not Entered.

To reset Message Screen, clear the condition (if required) and then touch the screen.



Fig. 3-20

This page intentionally left blank.

# Operation Guide

---

## Chapter 4, Settings & Adjustments

Machine Adjustments

Component Replacement

## 4.1 Machine Adjustments

Periodically, the T-1000 will require readjustment or realignment of components to ensure proper operation. Adjustments may be required after transportation, excessive handling, or due to normal wear and tear.

## 4.2 Tracking and Alignment Adjustments

To avoid spillage of product in an automatic loading operation and loss of production in a manual loading operation, make machine adjustments to correct the tracking and alignment of the web of bags.

## 4.3 Compression (NIP) Roller Adjustment

The drive roll compression is the force that exists between the two feed rolls (rubber covered grooved roll and grooved aluminum roll). Not enough drive roll compression will prevent the bags from *tearing off* after each sealing operation. Too much drive roll compression will cause extra wear on the drive roll, motor, clutch and brake mechanisms.

Turn the power switch to the OFF position and unplug the power cord. Remove the left and right side covers. The compression adjustment is located on the lower outside right and left side-plates (Fig. 4-14 & Fig. 4-15).

Compression adjustment is a two step process. First, the upper and lower roller are adjusted to make the lower roller parallel to the upper roller. Then, the lower roller is adjusted (raised) for proper compression.

On both the left panel and right panel, loosen the two locking bolts on the upper block of the compression tension assembly. Loosen the nut on the adjustment screw. With the inner frame locked in the UP position, lower the lower roller by turning the adjustment screws counter-clockwise until the lower roller is parallel to the upper roller and leaving 1/16" gap between the rollers. Turn the adjustment screw clockwise alternatively, keeping the lower roller parallel with the upper roller until the rollers come in contact across the width of the rollers. Slightly lower the inner frame and raise again to ensure that when raised again, the rollers touch simultaneously. Then "snug" the upper block bolts and recheck the alignment.

*Note (TIP): A light source (lamp) positioned to the rear of the T-1000 showing light in the gap of the rollers will assist in judging whether the upper and lower roller are parallel.*

With the rollers slightly touching and parallel, turn each adjustment screw approximately 1/2 turn clockwise. Then test the compression by putting a bag between the rollers. Holding the brake pulley to stop it from turning, attempt to pull the bag between the rollers. If the bag pulls out easily, turn the compression adjustment screws 1/2 turn clockwise.

Continue this adjustment until the bag is slightly difficult to pull out of the rollers.

*Caution: Over-tightening of the compression adjustment screws may cause damage to the upper (rubber) roller or the motor and excessive wear on the clutch.*



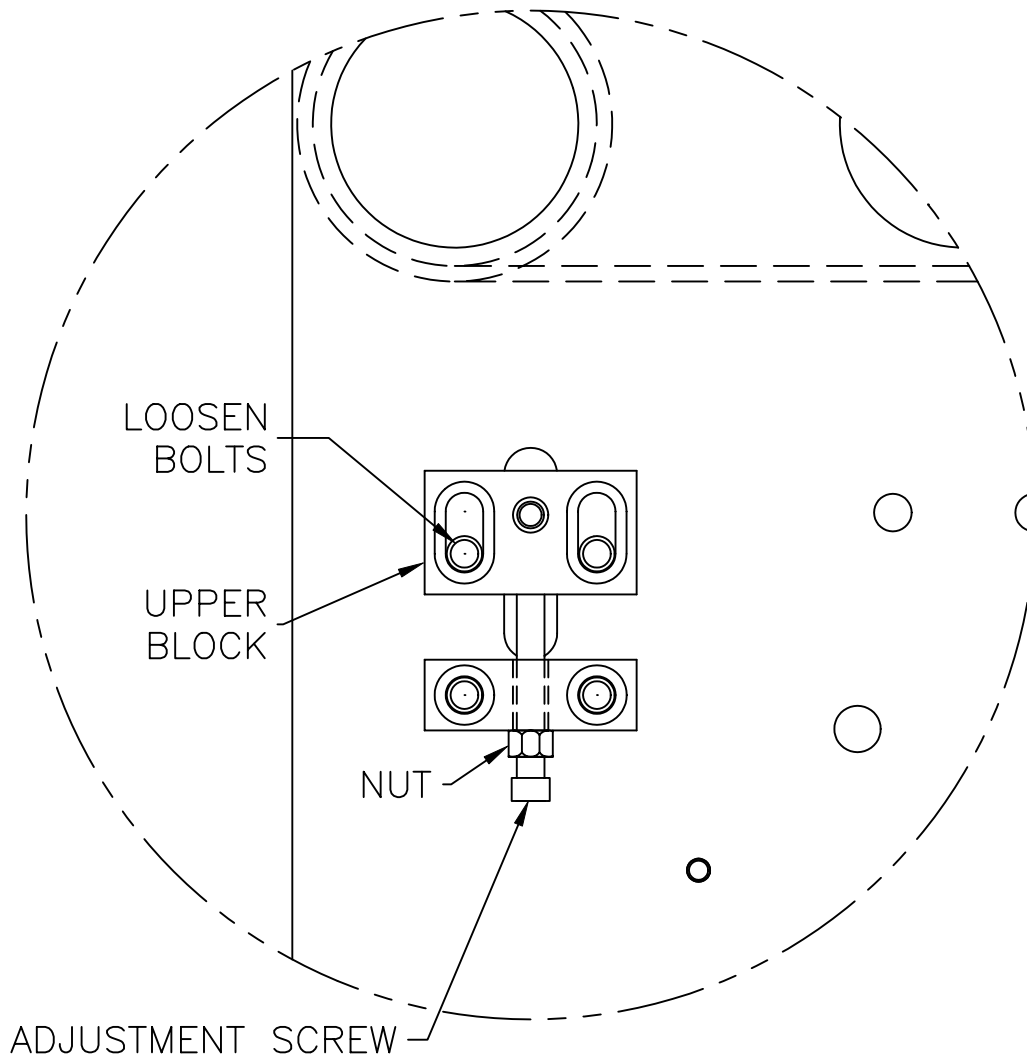

# LEFT SIDE PANNEL

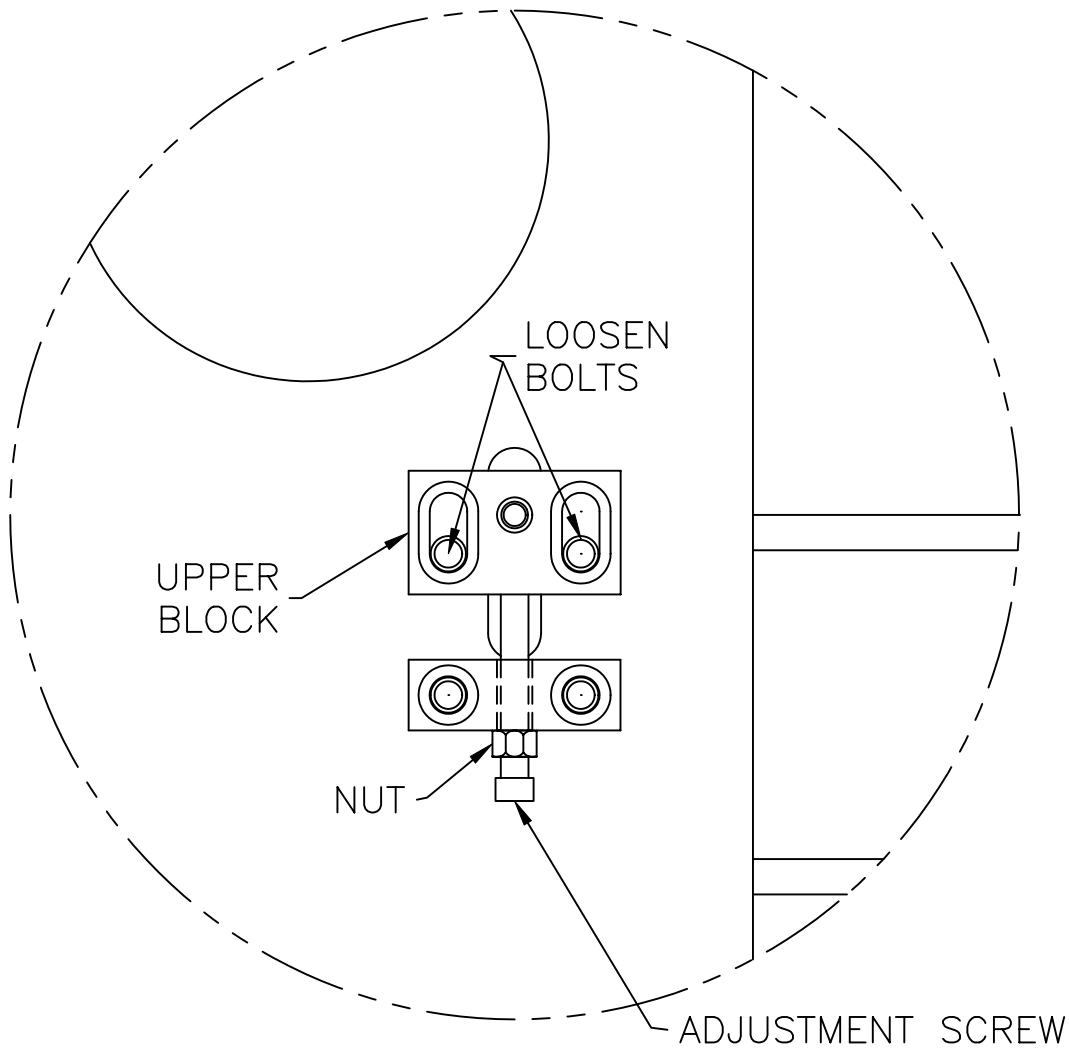

QUANTITY		-		FIGURE 4-14			
MATERIAL		-		 Advanced Poly Packaging Inc.			
FINISH		-		1331 Emmitt Road * Akron * Ohio 44306 Phone: 330-785-4000 * Fax: 330-785-4010			
TOLERANCES UNLESS OTHERWISE NOTED: +/- .015 ON FRACTIONAL DIMENSIONS +/- .010 ON TWO PLACE DECIMAL DIMENSIONS +/- .003 ON THREE PLACE DECIMAL DIMENSIONS 125 ✓ ON MACHINED SURFACES ALL DIMENSIONS ARE IN INCHES PART MUST BE FREE OF BURRS AND SHARP EDGES				TYPE EQUIPMENT		B/M REF. NO.	PART NO.
				T-1000			-
				SCALE		DRAWN BY	
				1:1		APPROVED	
				NAME		NAME	
				MELODY			
				DATE		DATE	
				12/05/01			
NOTICE: THIS DOCUMENT CONTAINS PROPRIETARY INFORMATION AND IT SHALL NOT BE USED OR REPRODUCED OR IT'S CONTENT DISCLOSED, IN WHOLE OR PART, WITHOUT THE PRIOR WRITTEN CONSENT OF ADVANCED POLY-PACKAGING INC.				TITLE		DRAWING NO.	
				COMPRESSION (NIP) ROLLER ADJUSTMENT		TP-T1E08	
						REV.	
						-	

# RIGHT SIDE PANNEL



QUANTITY	-	FIGURE 4-15		
MATERIAL	-	 <b>Advanced Poly Packaging Inc.</b> <small>1331 Emmitt Road * Akron * Ohio 44306                  Phone: 330-785-4000 * Fax: 330-785-4010</small>		
FINISH	-		TYPE EQUIPMENT	B/M REF. NO.
TOLERANCES UNLESS OTHERWISE NOTED: +/- .015 ON FRACTIONAL DIMENSIONS +/- .010 ON TWO PLACE DECIMAL DIMENSIONS +/- .003 ON THREE PLACE DECIMAL DIMENSIONS 125 ✓ ON MACHINED SURFACES ALL DIMENSIONS ARE IN INCHES PART MUST BE FREE OF BURRS AND SHARP EDGES		T-1000		-
		SCALE	DRAWN BY	APPROVED
		1:1	NAME MELODY	NAME
NOTICE: THIS DOCUMENT CONTAINS PROPRIETARY INFORMATION AND IT SHALL NOT BE USED OR REPRODUCED OR IT'S CONTENT DISCLOSED, IN WHOLE OR PART, WITHOUT THE PRIOR WRITTEN CONSENT OF ADVANCED POLY-PACKAGING INC.		TITLE	DRAWING NO.	REV.
		COMPRESSION (NIP) ROLLER ADJUSTMENT	TP-T1E07	-
		DATE 12/05/01	DATE	

When you are satisfied with the compression, slightly lower the inner frame and slowly raise it until it almost touches the upper roller. If the gap is consistent across the width of the rollers and it appears parallel, lock the inner frame upward and re-tighten the two locking bolts on the upper block of the compression tension assembly. Then re-tighten the nut on the adjustment screws.

Replace the covers, plug the cord into the power outlet and turn the main power on.

## 4.4 Dancer Assembly Adjustments (Roller Shaft)

A roller shaft, holding in position a roll of bags, will rest on the side-plates of the dancer assembly. The roller shaft must be parallel to the upper and lower guide rollers to allow proper tracking through the center of the T-1000. If the roller shaft is not parallel, the web of bags may track to the left or right.

*Note: The roller shaft should not be out of alignment unless damaged or jolted in shipment.*

## 4.5 Dancer Bar & Brake Strap Adjustment

The dancer assembly maintains proper bag web tension throughout the stop / start feed motion of the T-1000. Web tension is required for proper tracking. If the tension is insufficient, the web may track left or right. Thinner bags require less tension than thick bags. Web tension is created by friction of the brake strap along with the weight of the dancer bar pulling downward on the web of bags. Friction of the brake is created by the weight of the bag roll and the spring tension on the brake strap. As the dancer bar raises, spring tension is decreased and friction is decreased. If the web of bags is slack between the dancer roller and nip rollers, there is not enough tension on the bags. If the web of bags break prematurely, the tension is too high.

To correct the web tension, the dancer bar or brake strap spring must be adjusted (Fig. 4-16). To increase brake strap tension, relocate the spring on the dancer rail, one hole at a time, closer to the dancer roller. To decrease tension with the brake strap, move the spring on the dancer bar, one hole at a time, away from the dancer roller.

The dancer bar pivots on two shoulder bolts which extend from the side-plates. The downward force can be adjusted by repositioning the pivot point. To increase tension with the pivot position, move the pivot position away from the dancer roller. To decrease tension, move the pivot position closer to the dancer roller.

*Note: Inspect the dancer bar to ensure that it is parallel to the roller shaft.*

## 4.6 Upper Roller Guides

Two aluminum web guides, are located on the upper rear roll of the T-1000 used for *fine* adjustment of tracking. Once the web is tracking within +/- 1/8" left to right, the aluminum web guides can be used to further assist tracking. Hold the upper roller in place while turning and sliding the aluminum guides close to the bags without touching the bags.

*NOTE: If the bags are not tracking properly, the aluminum guides could cause the bag web to turn or fold over. If this occurs, slide the guides further away from the web and make adjustments to correct tracking as described in section 4.8.*

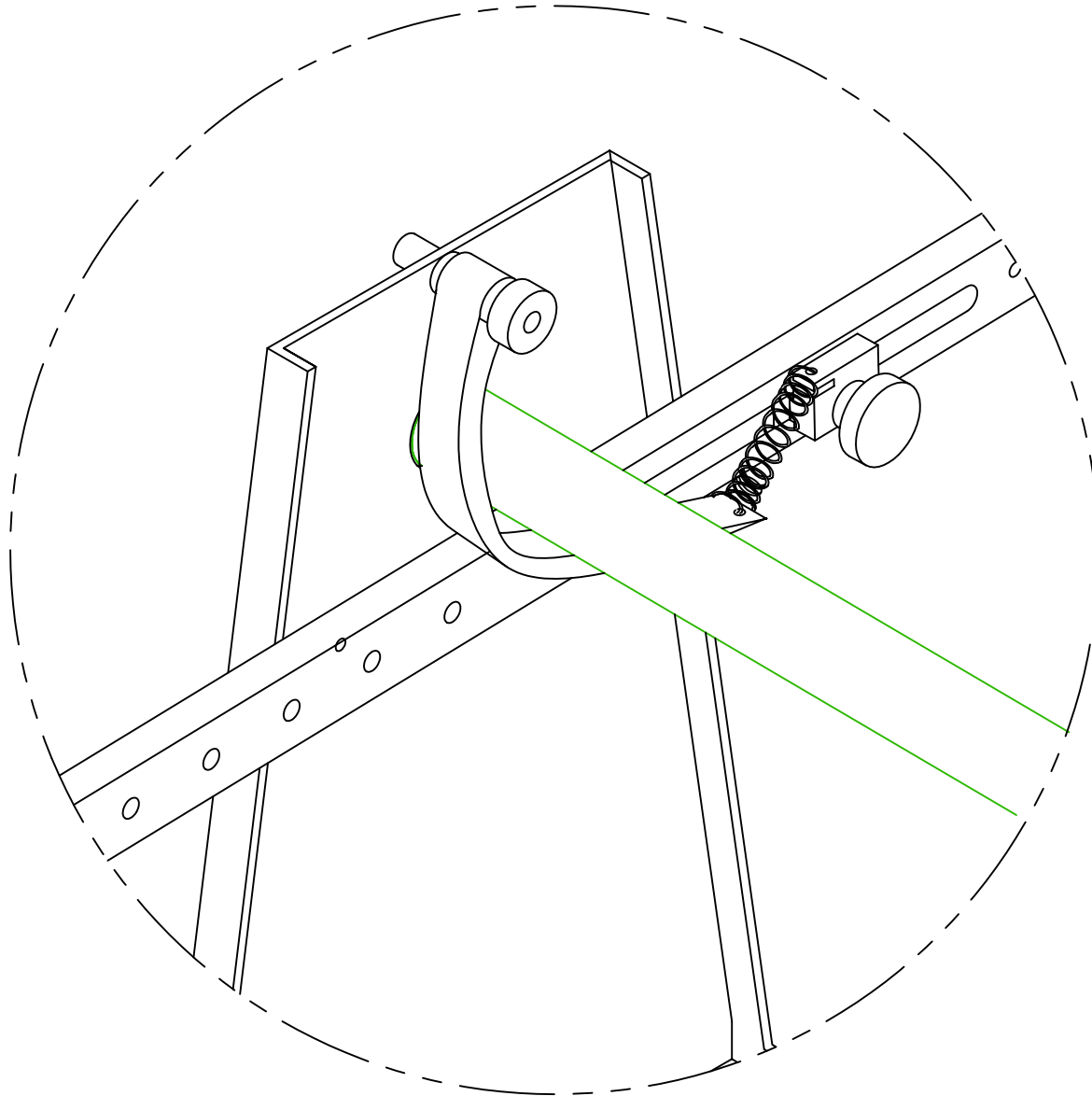

QUANTITY		-		FIGURE 2-2	
MATERIAL		-		 <b>Advanced Poly Packaging Inc.</b> <small>1331 Ewitt Road ■ Alton ■ Ohio 44306          Phone: 330-789-4900 ■ Fax: 330-789-4910</small>	
FINISH		-			
TOLERANCES UNLESS OTHERWISE NOTED: +/- .015 ON FRACTIONAL DIMENSIONS +/- .010 ON TWO PLACE DECIMAL DIMENSIONS +/- .003 ON THREE PLACE DECIMAL DIMENSIONS 125 ✓ ON MACHINED SURFACES ALL DIMENSIONS ARE IN INCHES PART MUST BE FREE OF BURRS AND SHARP EDGES				TYPE EQUIPMENT <b>T-1000</b>	
				B/M REF. NDL PART NDL -	
				SCALE <b>1:1</b>	
				DRAWN BY NAME MELODY DATE 12/05/01	
				APPROVED NAME DATE	
NOTICE: THIS DOCUMENT CONTAINS PROPRIETARY INFORMATION AND IT SHALL NOT BE USED OR REPRODUCED OR ITS CONTENT DISCLOSED, IN WHOLE OR PART, WITHOUT THE PRIOR WRITTEN CONSENT OF ADVANCED POLY-PACKAGING INC.				DRAWING NDL <b>TP-2-2</b>	
				REV. -	
				TITLE <b>DANCER ASSEMBLY</b>	

*NOTE: If bags have an air relief hole or hanger hole, shift the bag to the right or left of center to avoid having the hole pass directly under the perf sensor.*

*NOTE: Use the web guides for minor adjustments only. Major adjustment of the guides requires relocation of the bag roll on the bag roll shaft.*

## 4.7 PTFE Anti-Stick Sheet Adjustment

An Anti-Stick Sheet which prevents the bag from sticking to heater bar surfaces is located immediately behind the front plate. The sheet should periodically be inspected for wear or damage. If holes or tears exist, the rolls can be turned (rotated) to cover the contact surfaces with fresh material. If a *change* of material is required, turn the main power to the OFF position and unplug the power cord. Lower the inner frame by pulling the handle downward. The rollers are located on the outside lower frame, on the left and right side of the inner frame which extends beneath the side-plates (Fig. 4-17). To adjust the sheet, turn the lower roller clockwise approximately 1/4 turn using a flathead screwdriver. When fresh material is in place, turn the roller counterclockwise releasing ALL of the tension on the sheet

*CAUTION: If sheet tension is not released, the material will tear when the seal bar engages.*

## 4.8 PTFE Anti-Stick Sheet Replacement

Turn the power to the OFF position and unplug the power cord. Remove the four screws which hold the front plate to the inner frame. Pull the front plate from the inner frame and slide the front plate along the guide rods away from the seal assembly. Then slide the rollers and the roller holder away from the heater bar as a unit. Remove and discard the sheet. Replace the sheet and rollers with the new material wrapped on the upper roller. Place the rollers on the roller holder, ensuring springs are seated in the grooves on the rollers. Replace the rollers and holder as an assembly (with the unexpanded material on the upper roller). Replace the front plate and tighten the four screws. Adjust the material as described in section 4.12.

*Note: Fiber spacers are located behind the front gripper plate which may fall when removing the front plate screws.*

## 4.9 Pressure Bar Adjustment

The pressure bar, when actuated by the seal cylinder, is forced against the front plate. The pressure bar must be parallel to front plate to avoid excessive wear of components. Turn the power to the OFF position and unplug the power cord. Remove the air line from the regulator and remove the top cover. Once the air is removed, the pressure bar can freely be pushed toward the front plate. As the pressure bar approaches the front plate, you can see whether the pressure bar is parallel to the front plate. If it is not, remember which side of the pressure bar touches first; along with the distance of the gap on the opposite side. To make the pressure bar parallel to the front plate, the rear channel which holds the guide rods, must be adjusted. Loosen the nuts inside the channel. On the side opposite of the "touching" side, turn the nut, located on back side of the channel, clockwise the same distance the pressure bar was out of alignment. Tighten the inner-channel nuts and test the pressure bar again by sliding it in and out a few times.

RIGHT SIDE

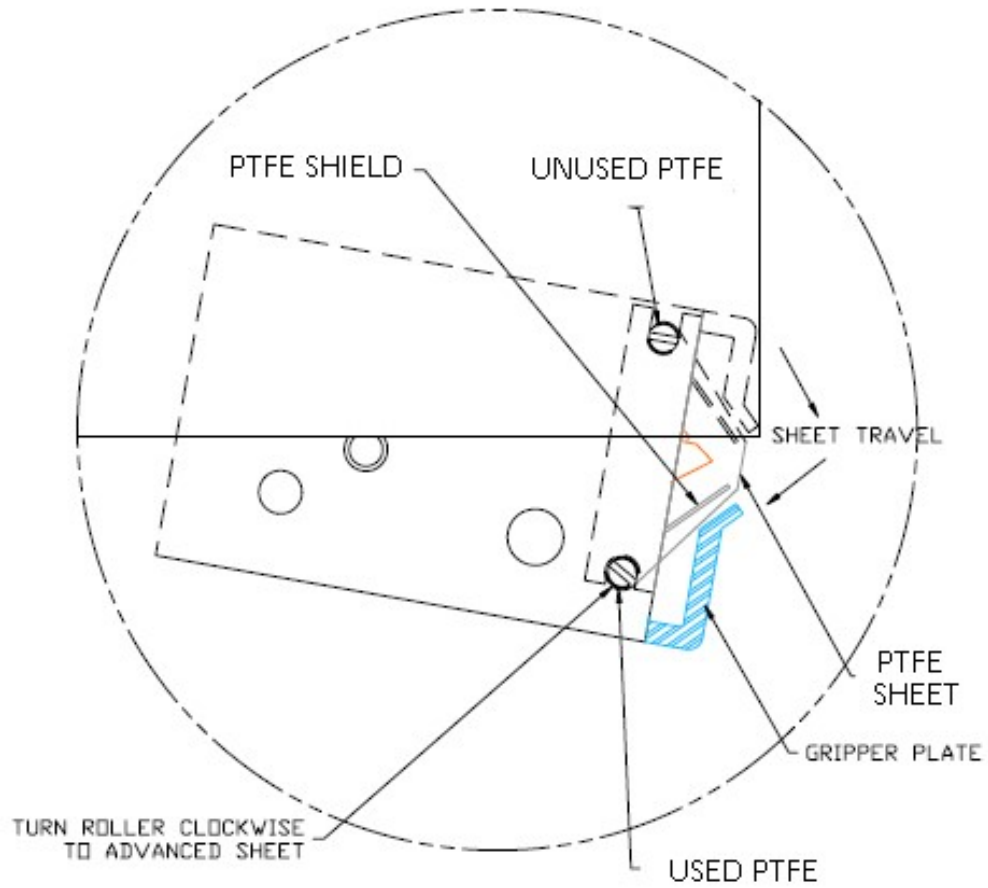

FIGURE 4-17



Advanced  
Poly Packaging Inc.

120 Ewell Road • Alton • Ohio 44396  
Phone: 330-785-4663 • Fax: 330-785-6333

TYPE EQUIPMENT T-1000	DWG REF. NO.	PART NO.
SCALE	DRAWN BY	APPROVED

Ensure it is parallel to the front plate by slowly pushing it against the front plate. Readjust the nuts on the rear channel as required.

*Note: Pressure bar adjustment should only be necessary after rod or bushing replacement.*

## 4.10 Drive Belt Tension Adjustment

The T-1000 has two belts, one of which will periodically require adjustment. The drive belts (Fig. 4-18) will require adjustment if it becomes loose during normal operation.

Turn the power to the OFF position and unplug the power cord. Remove the right cover and inspect the tension of the belt by pressing down on the belt between the drive pulleys. The belt should flex approximately 1/4". If the belt appears too loose, loosen the screw which is fastened to the drive belt tension assembly and push bearing tightly against the belt. Tighten the screw and test the tension. If sufficient, replace the cover, plug in the power cord, and turn on the T-1000. *Note: If the belt "chatters", it is too tight.*

## 4.11 Sealer Cylinder Adjustment

Two "speed controls" operate the speed of the cylinder in and out motion that brings the pressure bar against the front plate (gripper plate). Increasing the speed of the pressure will increase production. But, if the pressure bar moves in or out too fast causing the pressure bar to "bang", excessive wear will occur. The valve which controls the pressure bar cylinder is located on the main center cylinder on the inner frame (Fig. 4-19). The adjustment knob (B) controls the speed of the pressure bar INWARD (towards the front plate). The adjustment knob (A) controls the speed of the pressure bar OUTWARD (away from the front plate). To decrease the speed of the pressure bar INWARD, turn the knob (B) counter clockwise. To decrease the speed of the pressure bar INWARD, turn the knob (B) clockwise. To increase the speed of the pressure bar OUTWARD, turn the knob (A) counter clockwise. To decrease the speed of the pressure bar OUTWARD, turn the knob (A) clockwise. Adjust the speed of the pressure bar so that it moves in and out rapidly, in a fluid manner, without causing the pressure bar to "bang" in or out.

## 4.12 Pressure Bar (Rubber) Replacement

Located along the inside of the pressure bar is a strip of rubber, held on the pressure bar by a channel, pressing on the edges of the rubber. The rubber compresses against the front (gripper) plate holding the bag in place during sealing and during bag tear off. If the rubber becomes brittle, torn, gouged, or otherwise worn, it should be replaced to assure strong seals.

To replace the pressure bar rubber, simply pull one end of the rubber from the channel. The rubber will come out of the channel quickly and easily. To install a fresh piece of rubber, press one edge of the rubber into the channel then the other edge. Work the rubber into the channel in small increments along the length of the channel (Fig. 4-20). If you used PTFE Anti-Stick tape to cover the surface of the rubber, place the PTFE Anti-Stick on the rubber along its length. If the PTFE Anti-Stick extends beyond the rubber, cut off the excess.

*Note: PTFE Anti-Stick may be added to the pressure bar rubber if the bag sticks to the rubber after loading and sealing. The bag may stick to the rubber if the product and bag is light in weight and if the rubber is dirty.*

*Note: Frequently clean the rubber with alcohol to remove buildup of dirt or other contaminants.*

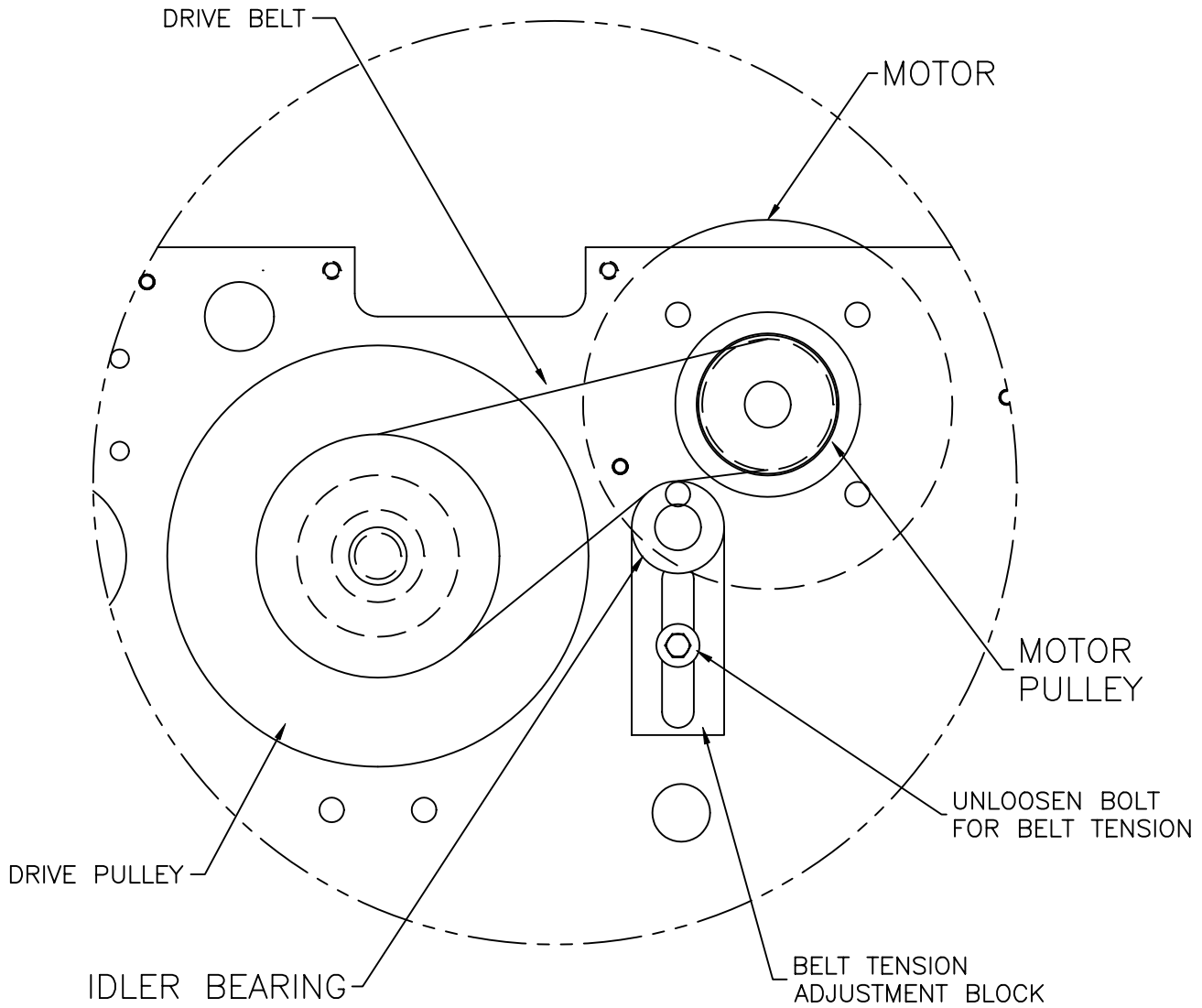

FIGURE 4-18



Advanced Poly Packaging Inc.

1331 Ewett Road ■ Alton ■ Ohio 44306  
 Phone: 330-785-4900 ■ Fax: 330-785-4010

TYPE EQUIPMENT T-1000	B/M REF. NO.	PART NO.
SCALE 1:1	NAME MELODY	DATE 10/25/01
	DATE	DATE

TITLE DRIVE BELT TENSION ADJUSTMENT	DRAWING NO. TP-T1E09	REV. -
--	-------------------------	-----------

NOTICE: THIS DOCUMENT CONTAINS PROPRIETARY INFORMATION AND IT SHALL NOT BE USED OR REPRODUCED OR ITS CONTENT DISCLOSED, IN WHOLE OR PART, WITHOUT THE PRIOR WRITTEN CONSENT OF ADVANCED POLY-PACKAGING INC.



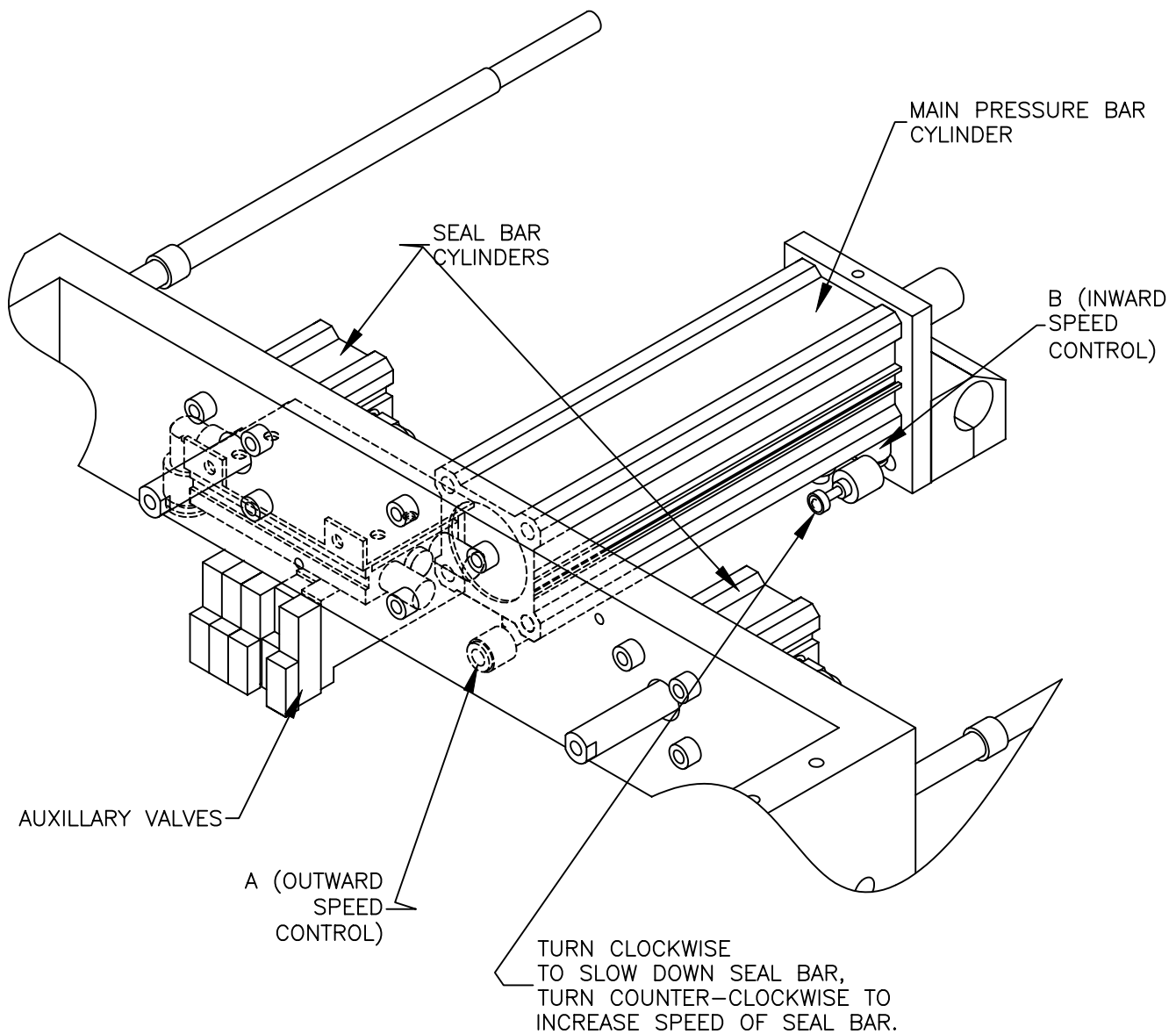

QUANTITY	-	FIGURE 4-19			
MATERIAL	-	 <b>Advanced Poly Packaging Inc.</b> <small>1331 Ewett Road ■ Akron ■ Ohio 44306          Phone: 330-785-4000 ■ Fax: 330-785-4010</small>			
FINISH	-	TYPE EQUIPMENT	B/M REF. NO.	PART NO.	
TOLERANCES UNLESS OTHERWISE NOTED +/- .015 ON FRACTIONAL DIMENSIONS +/- .010 ON TWO PLACE DECIMAL DIMENSIONS +/- .003 ON THREE PLACE DECIMAL DIMENSIONS 125 ✓ ON MACHINED SURFACES ALL DIMENSIONS ARE IN INCHES PART MUST BE FREE OF BURRS AND SHARP EDGES		T-1000		-	
		SCALE	DRAWN BY		APPROVED
		1:1	NAME MELODY	NAME	
			DATE 12/05/01	DATE	
NOTICE: THIS DOCUMENT CONTAINS PROPRIETARY INFORMATION AND IT SHALL NOT BE USED OR REPRODUCED OR ITS CONTENT DISCLOSED, IN WHOLE OR PART, WITHOUT THE PRIOR WRITTEN CONSENT OF ADVANCED POLY-PACKAGING INC.		TITLE	DRAWING NO.	REV.	
		INNER FRAME VALVE ADJUSTMENT	TP-T1B06	-	

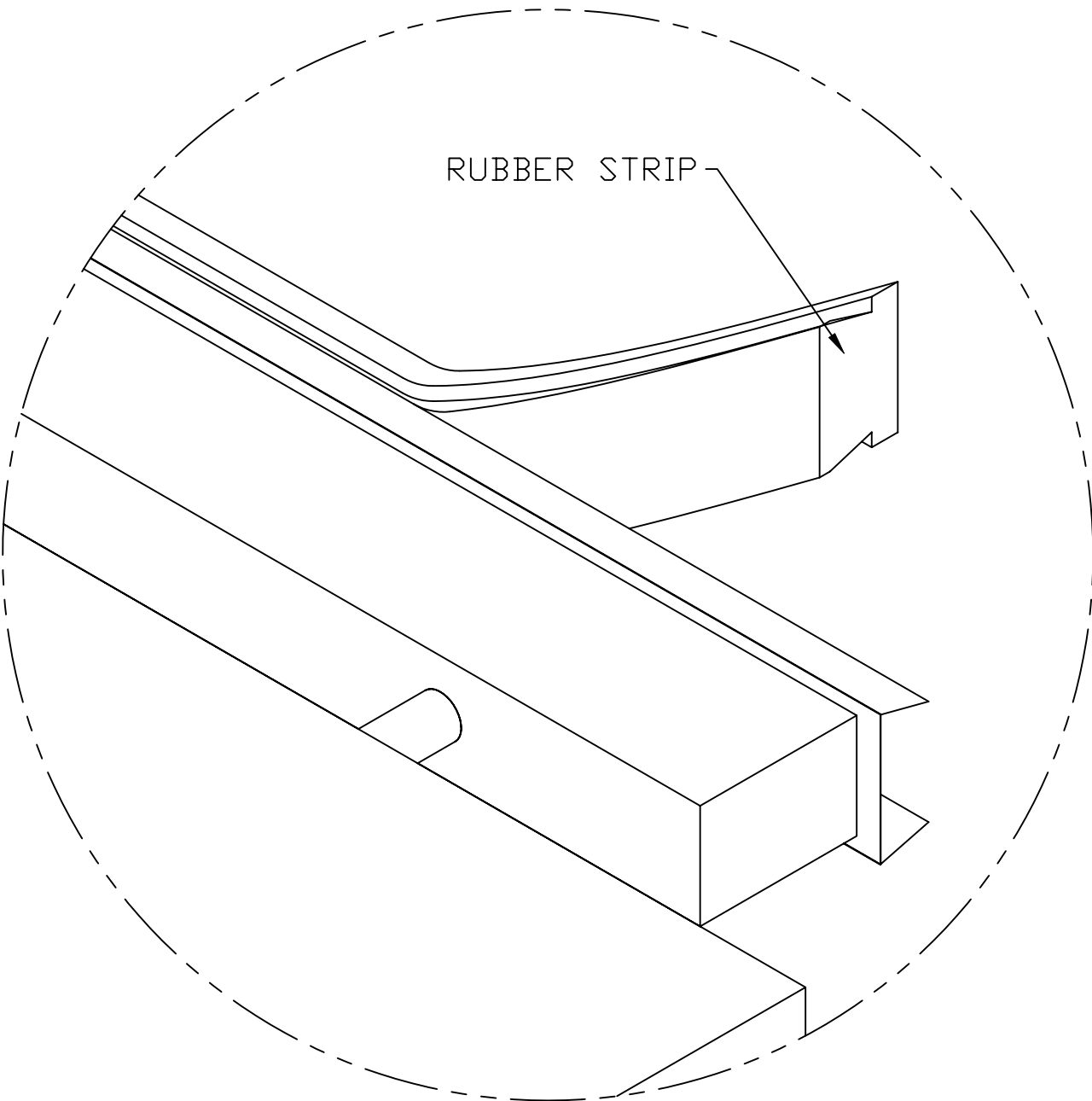

FIGURE 4-20

QUANTITY	-
MATERIAL	-
FINISH	-



Advanced  
Poly Packaging Inc.

1331 Emmitt Road \* Akron \* Ohio 44306  
Phone: 330-785-4000 \* Fax: 330-785-4010

TOLERANCES UNLESS OTHERWISE NOTED:

- +/- .015 ON FRACTIONAL DIMENSIONS
- +/- .010 ON TWO PLACE DECIMAL DIMENSIONS
- +/- .003 ON THREE PLACE DECIMAL DIMENSIONS
- 125 ✓ ON MACHINED SURFACES
- ALL DIMENSIONS ARE IN INCHES

PART MUST BE FREE OF BURRS AND SHARP EDGES

TYPE EQUIPMENT T-1000	B/M REF. NO.	PART NO. -
SCALE 1:1	DRAWN BY NAME MELODY DATE 12/13/011	APPROVED NAME DATE
TITLE PRESSURE BAR	DRAWING NO. TP-4-20	REV. -

NOTICE: THIS DOCUMENT CONTAINS PROPRIETARY INFORMATION AND IT SHALL NOT BE USED OR REPRODUCED OR ITS CONTENT DISCLOSED, IN WHOLE OR PART, WITHOUT THE PRIOR WRITTEN CONSENT OF ADVANCED POLY-PACKAGING INC.

## 4.13 Anti-Jam Adjustment

The anti-jam device is designed to protect the T-1000 from damage when an obstruction is encountered in the seal area (area between the pressure bar and front (gripper) plate). If properly adjusted, the pressure bar will retract if an obstruction is encountered in the seal area. The pressure bar houses springs which cause the rubber and holder to compress. When the rubber holder compresses, a sensor is activated causing the pressure bar to retract. The sensor is defeated when the pressure bar is approximately 1/8" from the gripper plate (Fig. 4-21). The anti-jam can quickly be tested while the T-1000 is operating using care, but should be thoroughly tested by disconnecting air and power and removing covers.

To quickly test the anti-jam device, place a 3/8" diameter flexible poly tube against the front (gripper) plate perpendicular to the seal bar opening. Press the foot switch allowing the pressure bar to compress the poly tube against the front plate. If the pressure bar does not immediately retract and place the T-1000 in the STOP mode, the anti-jam device is not properly adjusted. Test the anti-jam device along the entire length of the pressure bar using the 3/8" poly tubing as a test device.

*CAUTION: To avoid personal injury, do not place fingers or hands into the seal area of the T-1000 while power is ON or air is attached. Do not test the anti-jam device with hands or fingers. Ensure the poly tube which is used for testing is long enough to keep fingers or hands away from the seal area of the T-1000.*

To thoroughly test and adjust the anti-jam device, you must first turn the power to the OFF position, disconnect the air line from the T-1000 and remove the top and left side cover. With the covers removed and air disconnected, turn the power to the ON position.

To test the pressure bar sensor, locate the "X3" LED on the PLC Board (Fig. 4-8) and ensure the light is illuminated (ON). Then, compress the rubber and holder into the pressure bar (nylon holder). As soon as the rubber is pressed into the nylon holder, the "X3" LED should turn OFF. The LED should remain OFF while the rubber is held compressed into the nylon holder. If the "X3" LED shuts OFF while the rubber bar is pressed into the nylon holder, the pressure bar sensor is functioning properly.

To test the anti-jam override sensor, locate the "X7" LED on the PLC board (Fig. 4-8) and ensure that the light is OFF. Then, standing in front of the T-1000, push the pressure bar slowly towards the front plate, keeping hands and fingers out of the seal area. While pushing the pressure bar towards the front plate do not compress the rubber into the nylon holder or touch the round nuts on the pressure bar (Fig. 4-21).

When the pressure bar rubber is approximately 1/8" from the front plate, "X7" LED should illuminate (ON).

If the LED illuminates prematurely (when the rubber is farther than 1/8" from the front plate), the anti-jam override sensor must be adjusted. An aluminum block, located on the right guide rod in the inner frame, houses a magnet (Fig. 4-22). The anti-jam override sensor detects the magnetic field sending the signal to the PLC. If illuminated prematurely, the "magnetic block" should be moved toward the front of the T-1000 along the guide rod.

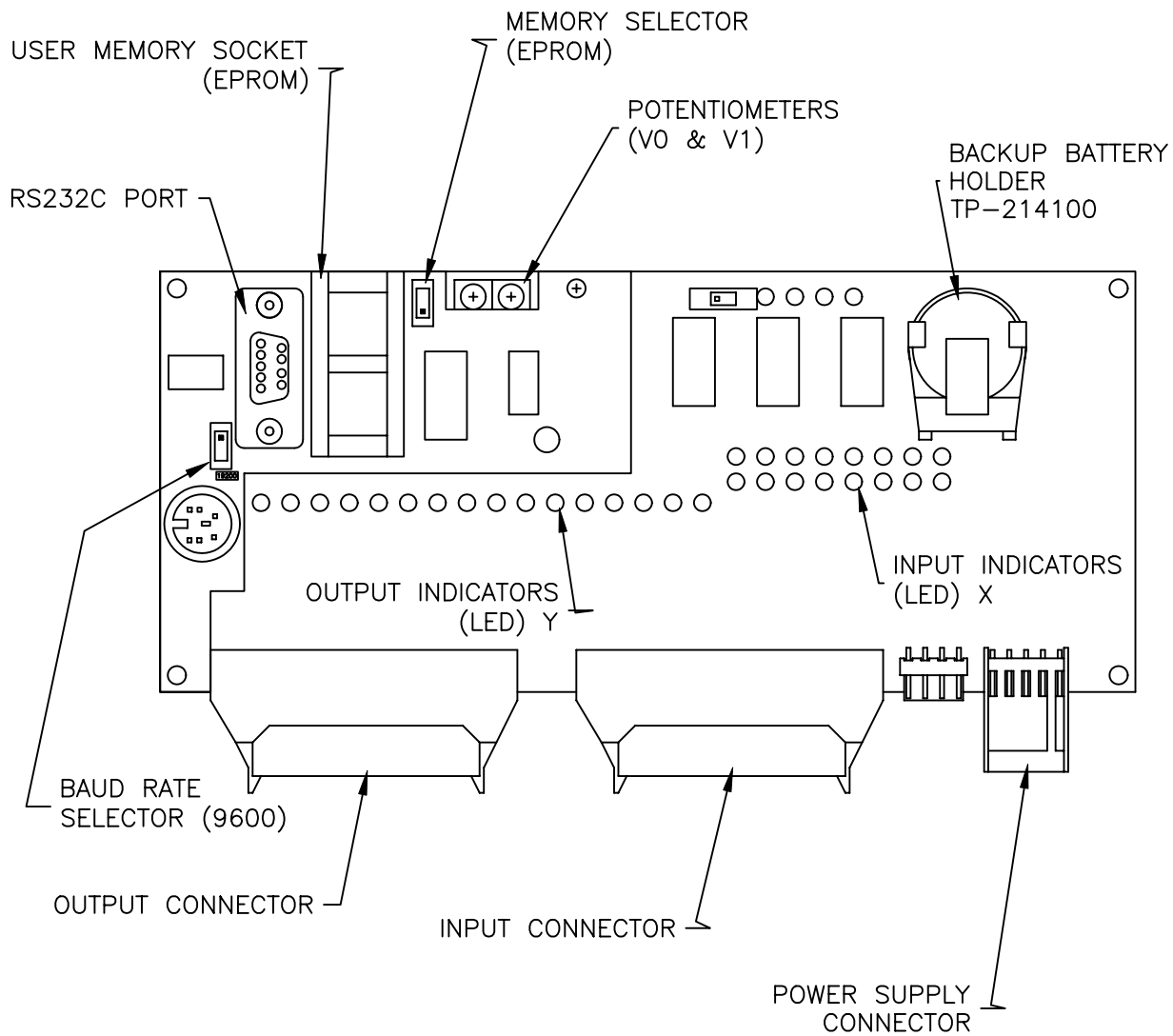

PLC  
TP-220367

FIGURE 4-8



Advanced  
Poly Packaging Inc.

1331 Emmitt Road \* Akron \* Ohio 44306  
Phone: 330-785-4000 \* Fax: 330-785-4010

TYPE EQUIPMENT T-1000	B/M REF. NO.	PART NO.
SCALE 1:1	DRAWN BY NAME MELODY DATE 10/24/00	APPROVED NAME DATE

NOTICE: THIS DOCUMENT CONTAINS PROPRIETARY INFORMATION AND IT SHALL NOT BE USED OR REPRODUCED OR ITS CONTENT DISCLOSED, IN WHOLE OR PART, WITHOUT THE PRIOR WRITTEN CONSENT OF ADVANCED POLY-PACKAGING INC.

TITLE PLC CONTROLLER BOARD	DRAWING NO. TP-T1E10	REV.
-------------------------------	-------------------------	------

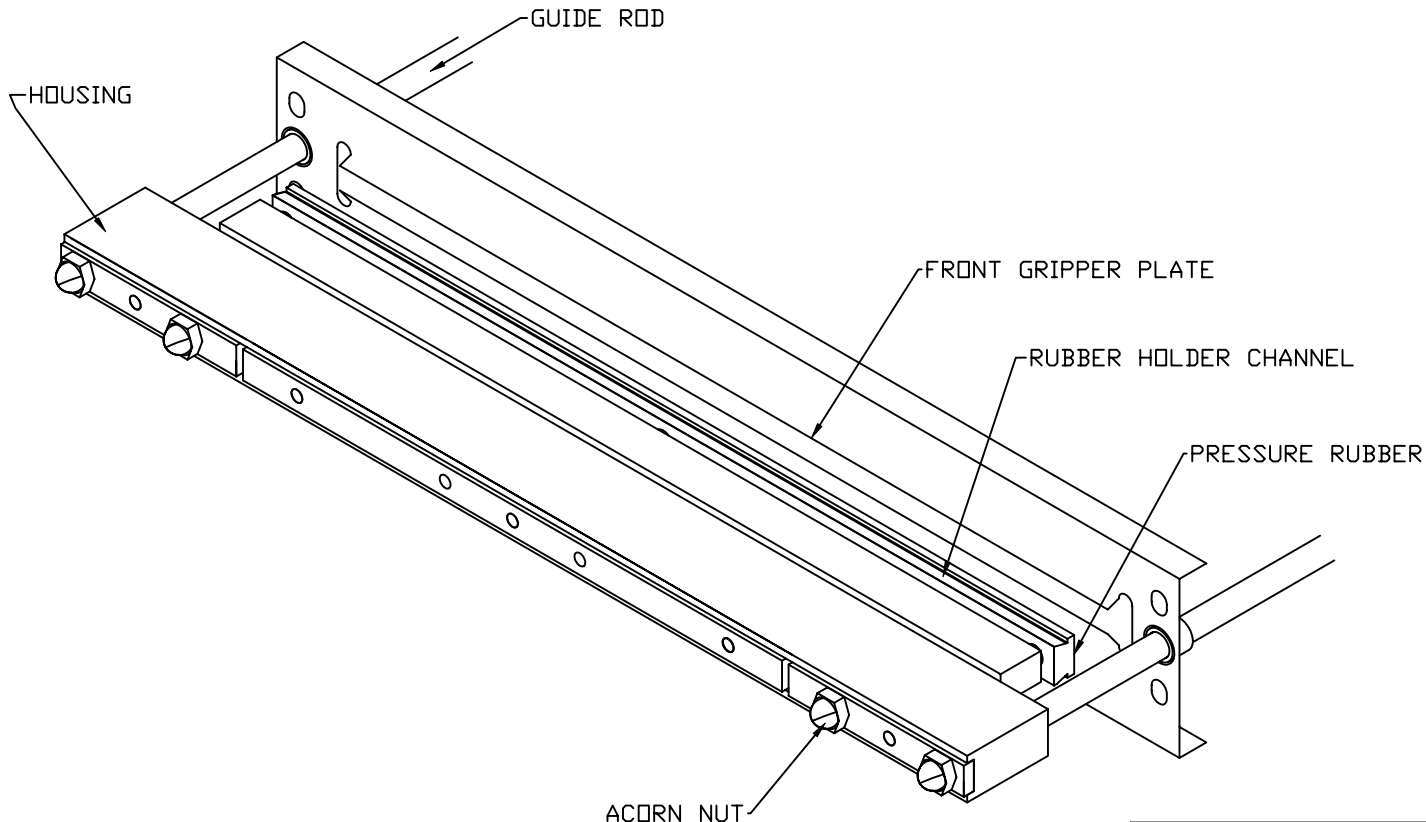

NOTE: 1/8" GAP BTW. PRESSURE RUBBER AND FRONT GRIPPER PLATE

FIGURE 4-21

 **Advanced Poly Packaging Inc.**

1231 Everett Road • Akron • Ohio 44306  
Phone: 330-785-0000 • Fax: 330-785-5999

TYPE EQUIPMENT T-1000	B/M REF. NO.	PART NO.
SCALE	DRAWN BY	APPROVED
NTS	NAME	MELODY
	DATE	10/23/01

NOTICE: THIS DOCUMENT CONTAINS PROPRIETARY INFORMATION AND IT SHALL NOT BE USED OR REPRODUCED OR ITS CONTENT DISCLOSED, IN WHOLE OR PART, WITHOUT THE PRIOR WRITTEN CONSENT OF ADVANCED POLY-PACKAGING INC.

TITLE ANTI-JAM ADJUSTMENT	DRAWING NO. TP-T1B02	REV. -
---------------------------------	-------------------------	-----------

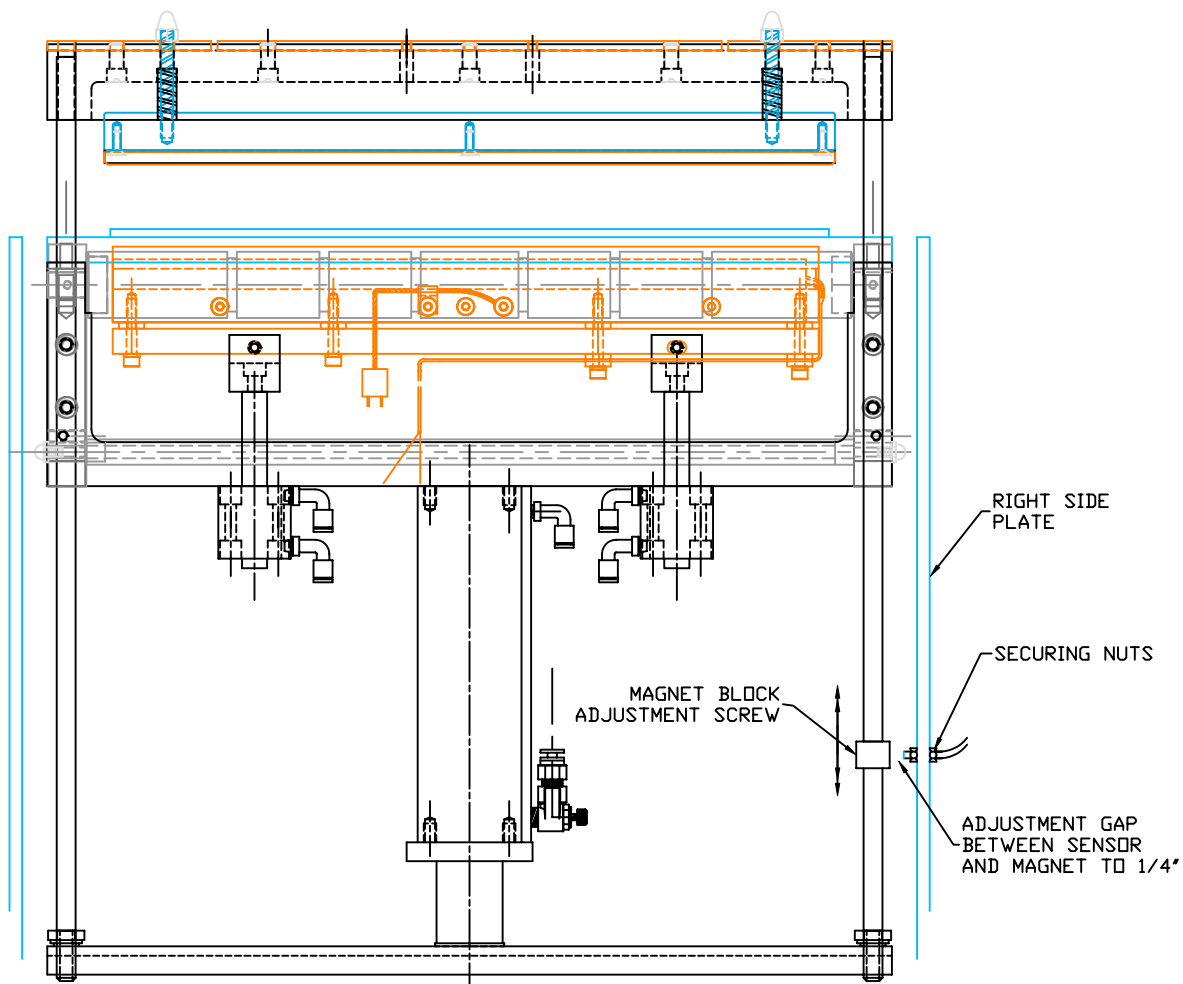

FIGURE 4-22



**Advanced Poly Packaging Inc.**

1331 Ewitt Road ■ Alton ■ Ohio 44306  
 Phone: 330-789-4900 ■ Fax: 330-789-4010

TYPE EQUIPMENT T-1000	B/M REF. NO.	PART NO. -
SCALE 1:2	DRAWN BY NAME MELODY DATE 12/05/01	APPROVED NAME DATE

NOTICE: THIS DOCUMENT CONTAINS PROPRIETARY INFORMATION AND IT SHALL NOT BE USED OR REPRODUCED OR ITS CONTENT DISCLOSED, IN WHOLE OR PART, WITHOUT THE PRIOR WRITTEN CONSENT OF ADVANCED POLY-PACKAGING INC.

TITLE ANTI-JAM OVER-RIDE ADJUSTMENT	DRAWING NO. TP-T1B03	REV. -
---	-------------------------	-----------

If the LED illuminates when the rubber is closer than 1/8" to the front plate or when the rubber is touching the rubber plate (illuminates late), the magnetic block should be adjusted by moving the magnetic block toward the rear of the T-1000 along the guide rod.

To move the magnetic block, loosen the screw on the block which secures it to the guide rod. Loosen the screw just enough to allow the magnet block to slide along the guide rod without pivoting.

After moving the magnetic block, pull the pressure bar away from the front plate and check the illumination of "X7" LED by pushing the pressure bar slowly toward the front plate. If out of alignment, move the magnetic block in 1/8" increments until properly positioned. In its final position along the guide rod, the magnetic block should be parallel to the side plate.

If the magnetic block, when parallel to the side plate and adjacent to the override sensor, does not cause the LED to illuminate, adjust the override sensor so that the sensor is closer to the magnetic block.

The override sensor is secured to the side-plate with two plastic nuts, one on either side of the side-plate. To bring the sensor closer to the magnetic block, loosen the nuts and turn the sensor counter clockwise, from inside the frame. Turn the sensor 1/2 turn at a time or until the "X7" LED is illuminated. When illuminated, turn 1/4 turn more.

*CAUTION: To avoid damaging the plastic override sensor, position the sensor so that it does not contact the magnetic block when the pressure bar is moving. To avoid "stripping" the threads of the sensor, do not over tighten the securing nuts.*

When properly positioned, secure the sensor by tightening the securing nuts. When properly adjusted and thoroughly tested, tighten the screw on the magnetic block, replace covers and connect the air line to the regulator.

## 4.14 Heater Cartridge Replacement

A cylinder-shaped cartridge (element), located inside the heater bar, heats the bronze bars which contain it. This cartridge is considered a normal wear item and will infrequently fail, requiring replacement.

To determine if the heater cartridge is bad, follow the following troubleshooting steps: 1) Locate "Y0" LED (Heater Circuit) on the PLC Board (Fig. 4-8) or the Heater Status Light on the Touch Screen Front Cabinet, beneath the Touch Screen (if installed on the T-1000). Press the <START> key if the T-1000 is in the Stop mode. If "Y0" illuminates in long pulses without increasing the Temperature on the Bag Setup Screen (page 32, Fig. 3-3) proceed to step two. 2) Check the heater fuse (F5), on the Interface Board (Fig. 4-10). If the fuse is good, proceed to step three. 3) Locate "N4" Neon Light (Heater Pulse AC) on the Interface Board (Fig. 4-9).

If the neon remains ON continuously, but at "half brightness", proceed to the final test. 4) Disconnect the heater connector labeled "Heater" in the inner frame and check the resistance with an Ohms meter. If the meter reads greater than 17-18 ohms, replace the newer style 800 watt cartridge. If the meter reads greater than 13 ohms, replace the older style 1200 watt cartridge.

# INTERFACE BOARD LIGHTS

## TP-200348

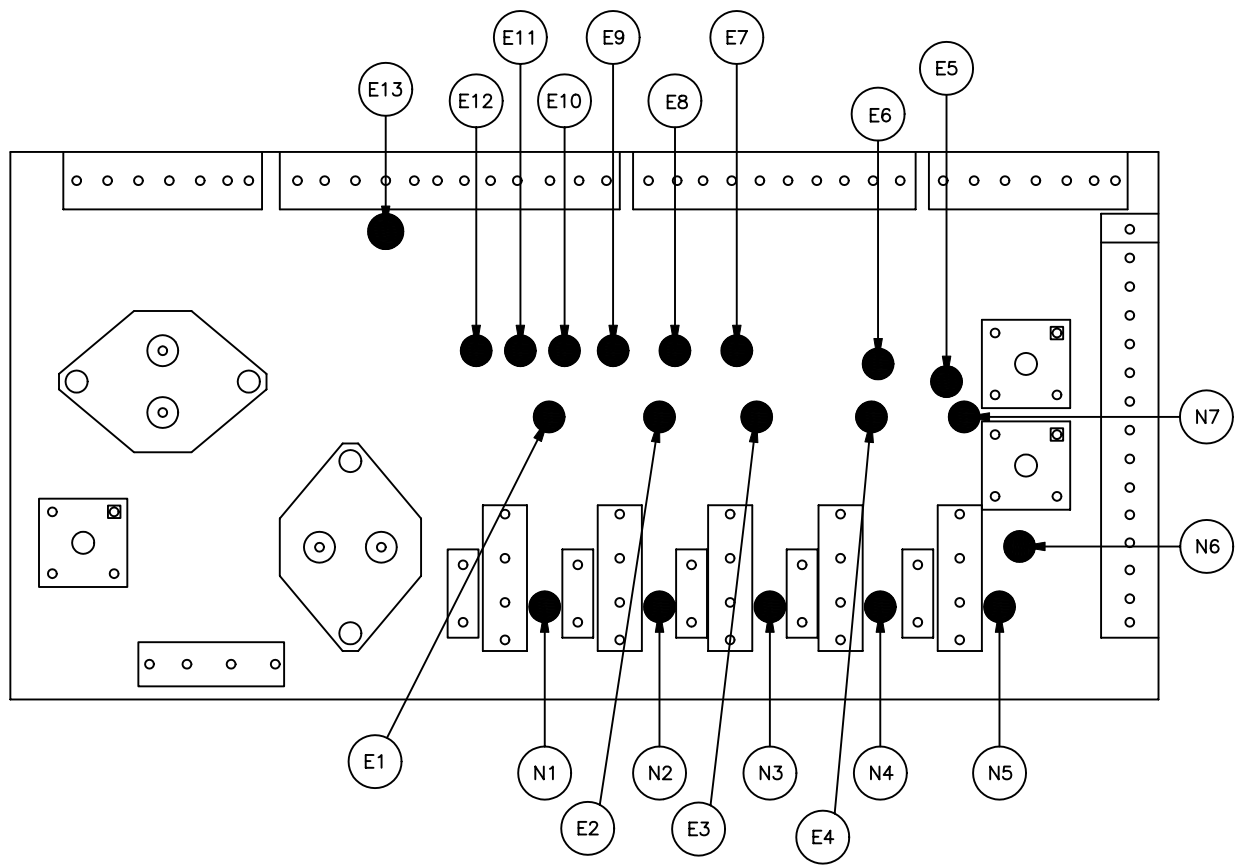

FIGURE 4-9



Advanced  
Poly Packaging Inc.

1331 Emmitt Road \* Akron \* Ohio 44306  
Phone: 330-785-4000 \* Fax: 330-785-4010

TYPE EQUIPMENT T-1000	B/M REF. NO. ELECTRICAL ASSEMBLY	PART NO.
SCALE FULL	DRAWN BY NAME MELODY DATE 10/25/00	APPROVED NAME DATE

NOTICE: THIS DOCUMENT CONTAINS PROPRIETARY INFORMATION AND IT SHALL NOT BE USED OR REPRODUCED OR IT'S CONTENT DISCLOSED, IN WHOLE OR PART, WITHOUT THE PRIOR WRITTEN CONSENT OF ADVANCED POLY-PACKAGING INC.

TITLE I.F. BOARD LIGHT DIAGRAM	DRAWING NO. TP-T1L01	REV.
--------------------------------------	-------------------------	------



# INTERFACE BOARD FUSES

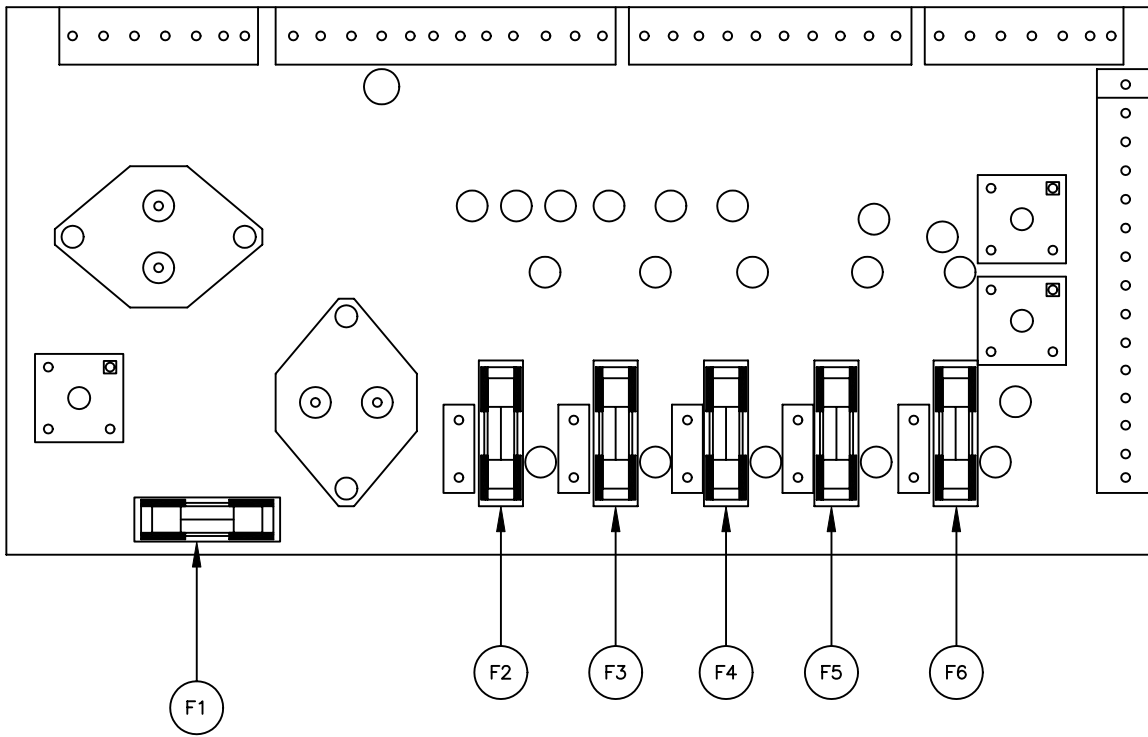

F1:FUSE – TP-207206

F2 – TP-207225

F3 – TP-207225

F4 – TP-207226

F5 – TP-207228

F6 – TP-207226

FIGURE 4-10



Advanced  
Poly Packaging Inc.

1331 Emmitt Road \* Akron \* Ohio 44306  
Phone: 330-785-4000 \* Fax: 330-785-4010

TYPE EQUIPMENT T-1000	B/M REF. NO. ELECTRICAL ASSEMBLY	PART NO.
SCALE FULL	DRAWN BY NAME MELODY DATE 10/25/00	APPROVED NAME DATE

NOTICE: THIS DOCUMENT CONTAINS PROPRIETARY INFORMATION AND IT SHALL NOT BE USED OR REPRODUCED OR IT'S CONTENT DISCLOSED, IN WHOLE OR PART, WITHOUT THE PRIOR WRITTEN CONSENT OF ADVANCED POLY-PACKAGING INC.

TITLE I.F. BOARD  
FUSE DIAGRAM

DRAWING NO.  
TP-T1L02

REV.

Note: If you do not have an Ohms meter, replace the heater cartridge after step three.

To replace the heater cartridge, turn the main power to the OFF position, unplug the power cord and disconnect the air line.

Disconnect the heater cartridge wire at the connector. From underneath the inner frame, loosen and remove the screws which holds the wire clamp and lower heater bar plate to the upper heater bar plate (Fig. 4-23). Then remove the two remaining screws which hold the lower heater bar plate to the upper heater bar plate. Remove the heater cartridge wires from the wire clamp. Place a new cartridge into the heater bar slot and replace the lower heater bar plate. Place the wires into the wire clamp and secure to the lower heater bar plate. Reconnect the heater cartridge wires ensuring that the heater bar can extend fully without stretching the heater cartridge wires. Plug the cord into the outlet, turn the power to the ON position and connect the air line to the regulator. Press <START> on the Touch Screen and verify that the temperature increases.

## 4.15 Replace Thermocouple Wire

A thermocouple wire, brazed to a ring terminal and secured to the top of the upper heater bar, detects the amount of heat the heater bar is emitting. The thermocouple wire is considered a normal wear item and will infrequently fail, requiring replacement.

To determine if the thermocouple is bad, follow these troubleshooting steps: 1) Locate the "E13" light (Open Thermocouple Alarm) on the Interface Board (Fig. 4-9). If the light is ON, proceed to step two. 2) Another indicator that the thermocouple wire is bad is the "XO" (Heater Bar Temp. Readout) LED on the P.C. Board (Fig. 4-8) will flash slowly. 3) Additionally, the "Y0" (Heater Circuit) LED (Fig. 4-8) will not be illuminated (unless the Energy Saver has shut off the heater bar after 25 minutes).

If the above conditions are met, the thermocouple is bad and the current to the heater bar has been turned OFF.

To replace the thermocouple wire, turn the main power to the OFF position, unplug the power cord and disconnect the air line.

Remove the front plate and PTFE Anti-Stick assembly, as described in Chapter 4.13. Remove the screws which hold the ring terminal and the jacketed wire clamp. Disconnect the connector and remove the wire. Reverse these steps to replace the wire.

*CAUTION: To avoid stretching or breaking the wire during heater cylinder extension, ensure that the wire is looped and free to bend during heater bar movement.*

Replace the PTFE Anti-Stick assembly and front plate as described in Chapter 4.13.

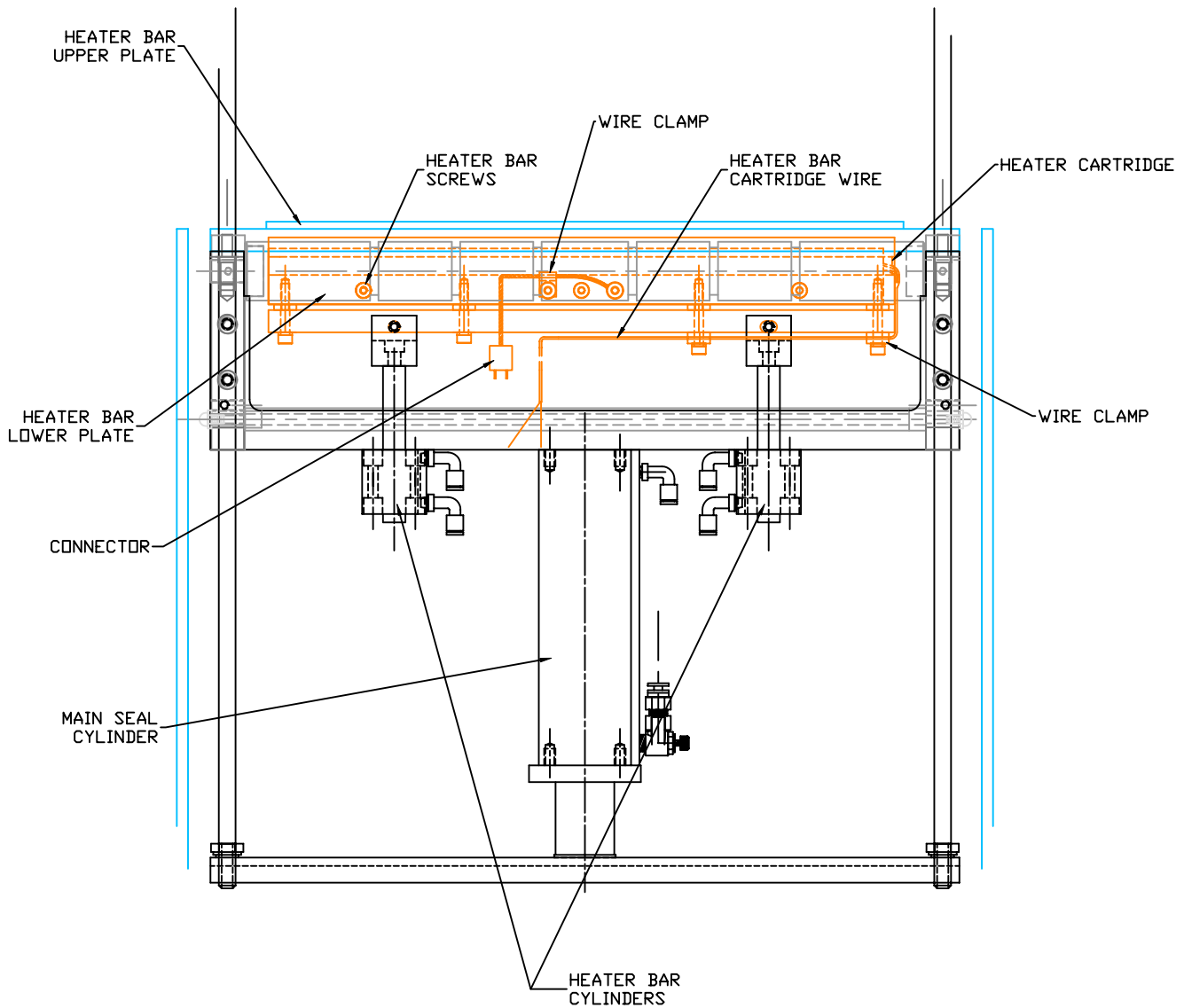

VIEW FROM UNDERNEATH INNER FRAME

FIGURE 4-23



Advanced Poly Packaging Inc.

1331 Ewett Road ■ Alton ■ Ohio 44306  
Phone: 330-789-4900 ■ Fax: 330-789-4910

TYPE EQUIPMENT T-1000	B/M REF. NO.	PART NO. -
SCALE 1:2	DRAWN BY NAME MELODY DATE 10/23/01	APPROVED NAME DATE

NOTICE: THIS DOCUMENT CONTAINS PROPRIETARY INFORMATION AND IT SHALL NOT BE USED OR REPRODUCED OR ITS CONTENT DISCLOSED, IN WHOLE OR PART, WITHOUT THE PRIOR WRITTEN CONSENT OF ADVANCED POLY-PACKAGING INC.

TITLE HEATER BAR CARTRIDGE REPLACEMENT DRAWING	DRAWING NO. TP-T1B04	REV. -
---	-------------------------	-----------

## 4.16 Brake Gap Adjustment

Once the brake is adjusted (at the factory), it should not require adjustment. But, if the brake is not functioning properly, adjustment may be required.

To check the brake gap, turn the power to the OFF position, disconnect air and remove the left panel cover. Using a .014 Feeler Gauge, insert the gauge between the outer plate and the second plate. If the gauge is "snug", the gap is properly set.

If the gauge is too loose or cannot be inserted between the plates, loosen the two set screws located on the brake collar (Fig. 4-24). Place the Feeler Gauge between the plates and press the outer plate against the feeler gauge. Press the brake collar against the outer plate and tighten the set screws. Replace the left cover, plug in the power cord, connect the air line and turn the main power to the ON position.

## 4.17 Battery Replacement .

The T-1000 has a backup battery located on the PLC board. Battery Types: PLC Battery - Model No. AFB8801. Lithium Battery, BR2032/CR2032 type or equivalent.

The life of the battery is 53,000 hours (approx. 6 years). The battery stores *current* configuration settings of the program. When jobs are no longer being saved in the PLC, replace the battery. To replace the battery from the PLC remove the left cover and PLC plastic cover. Remove the battery as illustrated on Figure 4-25, using a small insulated screw driver, with the positive side (+) facing you.

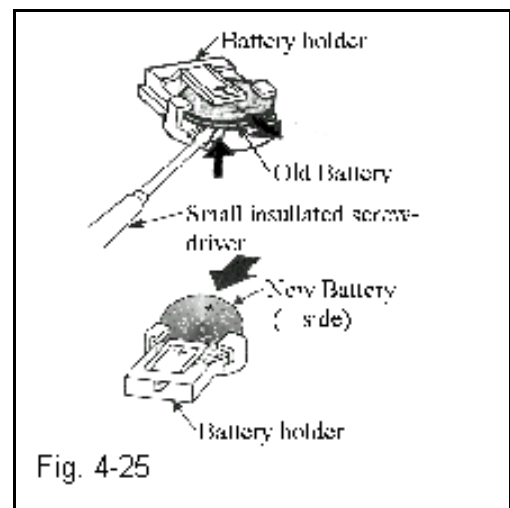

When replacing the battery, you will not lose settings if a new battery is replaced within 3 minutes after the low battery has been removed.

**CAUTION:** *If you fail to use insulated tools, they may cause a short-circuit between the battery and the equipment.*

## 4.18 PLC EPROM Installation Instructions

For IOP Version T-1000

Note: Please read the following instructions carefully to prevent damage to components and avoid loss of data.

1. Ensure the T-1000 power is turned OFF.
2. Remove the right side (as you are facing the front of the T-1000) cover by first removing the bolt then pulling the cover outwards on bottom and then lifting upwards to remove.
3. The PLC is located towards the back top portion of the right panel.  
Pull back the plastic cover on the PLC without removing.
4. The EPROM is located on the top left side of the PLC.  
Refer to Fig. 4-8 of the T-1000 manual (User memory socket).

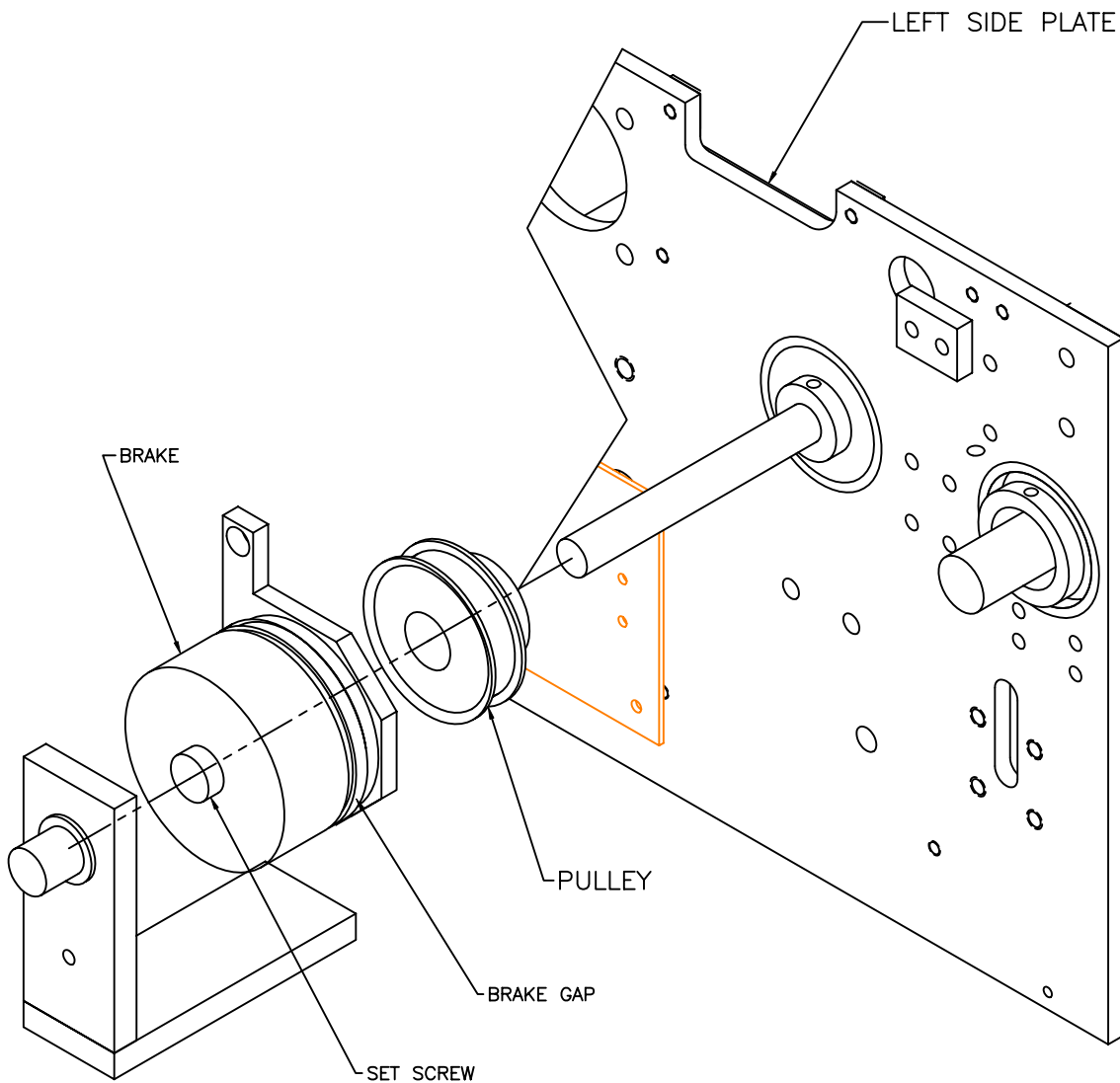

FIGURE 4-24



Advanced  
Poly Packaging Inc.

1331 Emmitt Road \* Akron \* Ohio 44306  
Phone: 330-785-4000 \* Fax: 330-785-4010

TYPE EQUIPMENT T-1000	B/M REF. NO.	PART NO.
SCALE 1:2	DRAWN BY NAME MELODY DATE 10/24/00	APPROVED NAME DATE

NOTICE: THIS DOCUMENT CONTAINS PROPRIETARY INFORMATION AND IT SHALL NOT BE USED OR REPRODUCED OR ITS CONTENT DISCLOSED, IN WHOLE OR PART, WITHOUT THE PRIOR WRITTEN CONSENT OF ADVANCED POLY-PACKAGING INC.

TITLE BRAKE GAP ADJUSTMENT	DRAWING NO. TP-T1B05	REV.
----------------------------------	-------------------------	------

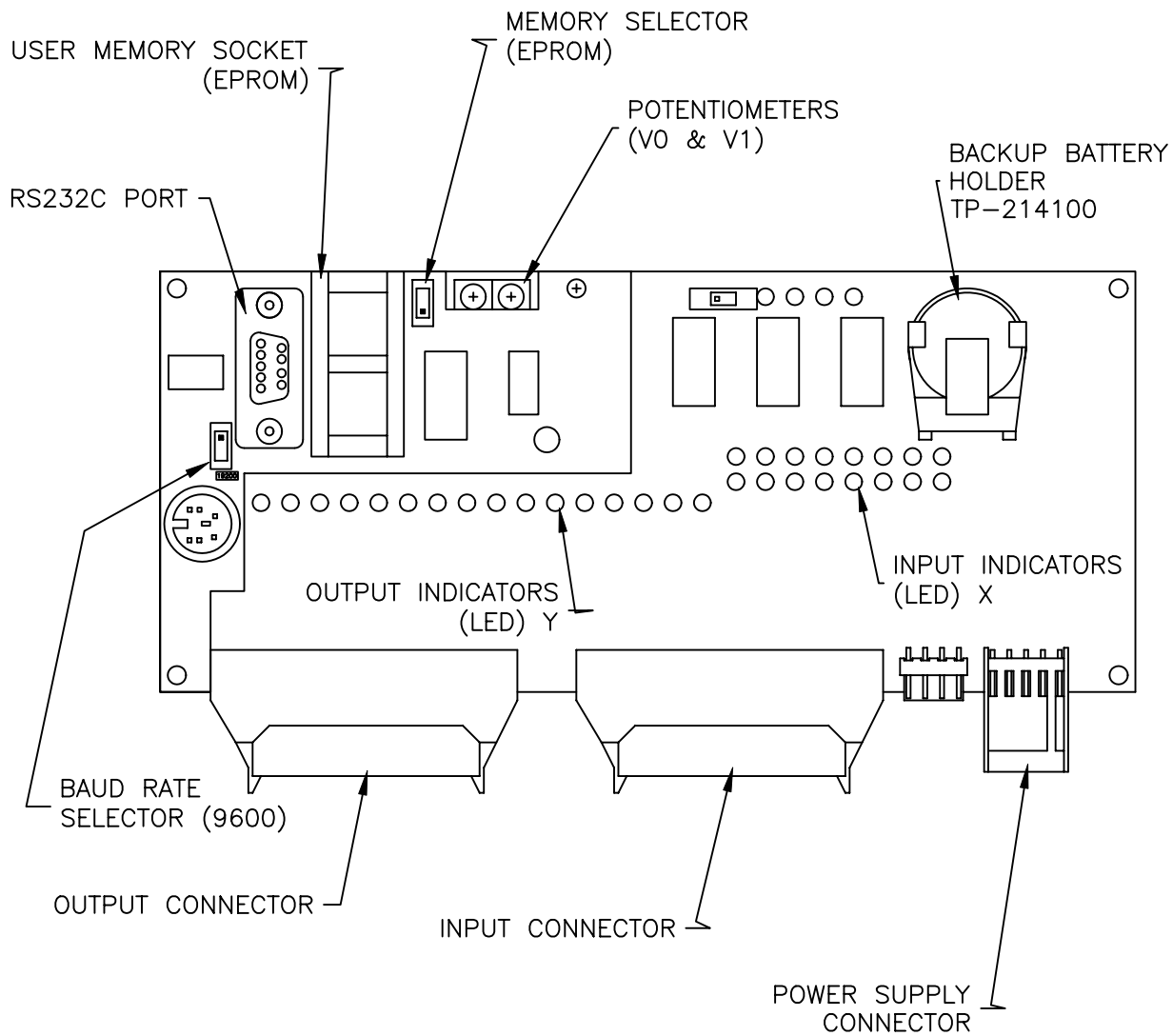

PLC  
TP-220367

FIGURE 4-8



Advanced  
Poly Packaging Inc.

1331 Emmitt Road \* Akron \* Ohio 44306  
Phone: 330-785-4000 \* Fax: 330-785-4010

TYPE EQUIPMENT T-1000	B/M REF. NO.	PART NO.
SCALE 1:1	DRAWN BY NAME MELODY DATE 10/24/00	APPROVED NAME DATE

NOTICE: THIS DOCUMENT CONTAINS PROPRIETARY INFORMATION AND IT SHALL NOT BE USED OR REPRODUCED OR ITS CONTENT DISCLOSED, IN WHOLE OR PART, WITHOUT THE PRIOR WRITTEN CONSENT OF ADVANCED POLY-PACKAGING INC.

TITLE PLC CONTROLLER BOARD	DRAWING NO. TP-T1E10	REV.
-------------------------------	-------------------------	------

5. Remove the existing EPROM by holding it top to bottom and carefully remove.
6. When installing new EPROM, insert with notch facing upwards and carefully inset into socket.
7. Change the MODE SELECTOR switch from RUN to PROGRAM and turn power ON.
8. Turn power to OFF, and turn MODE SELECTOR switch to REMOTE and turn power back on.
9. Turn power OFF and switch MODE SELECTOR to RUN and turn power ON.
10. The BAUD RATE switch and MEMORY SELECTOR should be facing upwards.
11. You have now finished downloading the new program.

#### PLC EPROM INSTALLATION INSTRUCTIONS

For TOUCH SCREEN Version T-1000

1. Complete steps 1-9.
2. Turn power OFF.
3. The BAUD RATE switch should be facing DOWN, and the MEMORY SELECTOR switch should be UP.
4. Turn power ON.
5. You have now now finished downloading the new program.

This page intentionally left Blank.



# Operation Guide

---

## Chapter 5

Parts Dwgs

Spare Parts Kits

## 5.1 Main Assembly => T-T1000

### T-1000 Advanced Poly-Bagger

See Dwg #T-T1000

1	TA-T10100	Head Assembly, T-1000
2	TA-T10199	Stand Assembly, T-1000
3	TA-T10240	Touch Screen Control Case Assembly

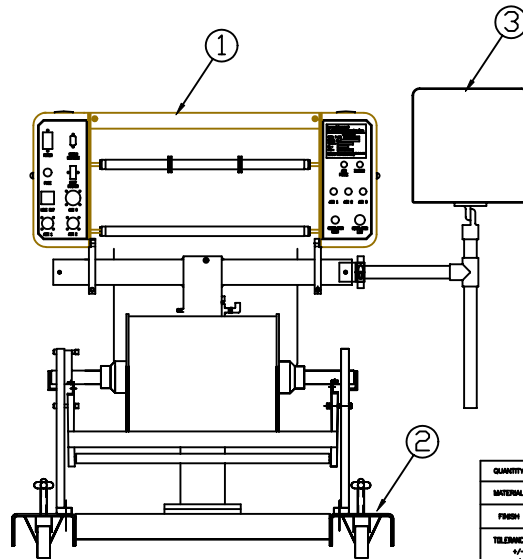
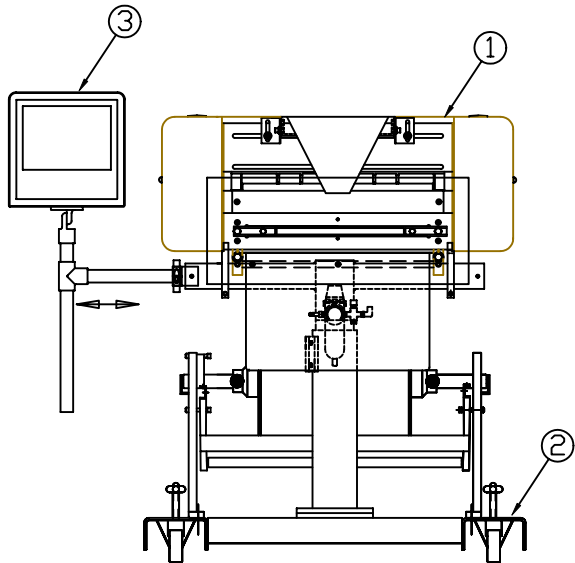
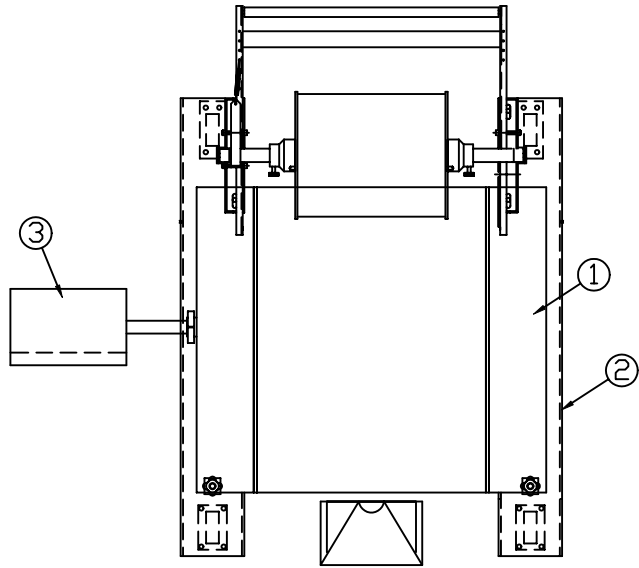

QUANTITY	REV	DATE	BY	DESCRIPTION
—				
MATERIAL				
FINISH				
TOLERANCES UNLESS OTHERWISE NOTED +/- .005 ON FRACTIONAL DIMENSIONS +/- .001 ON TWO PLACE DECIMAL DIMENSIONS +/- .001 ON THREE PLACE DECIMAL DIMENSIONS .025 ON HATCHED SURFACES ALL DIMENSIONS ARE IN INCHES PART MUST BE FREE OF BURRS AND SHARP EDGES				
NOTED: THIS DOCUMENT CONTAINS PROPRIETARY INFORMATION AND IT SHALL NOT BE USED OR REPRODUCED OR ITS CONTENTS DISCLOSED, IN WHOLE OR PART, WITHOUT THE PRIOR WRITTEN CONSENT OF ADVANCED POLY-PACKAGING INC.				
TYPE EQUIPMENT <b>T-1000</b>		DATE REV. NO. 4/10/01		PART NO. —
SCALE <b>1:5</b>		DRAWN BY MELUDDY	DATE 4/10/01	APPROVED DATE
TITLE <b>T-1000 BAGGER MACHINE ASSEMBLY</b>		DRAWING NO. <b>T-1000</b>		REV. —



**Advanced Poly Packaging Inc.**  
 220 South Road • Akron • Ohio 44325  
 Phone 330-726-2800 • Fax 330-726-2801

## 5.2 Assembly => TA-T10100

### Head Assembly, T-1000

See Dwg #TA-T10100

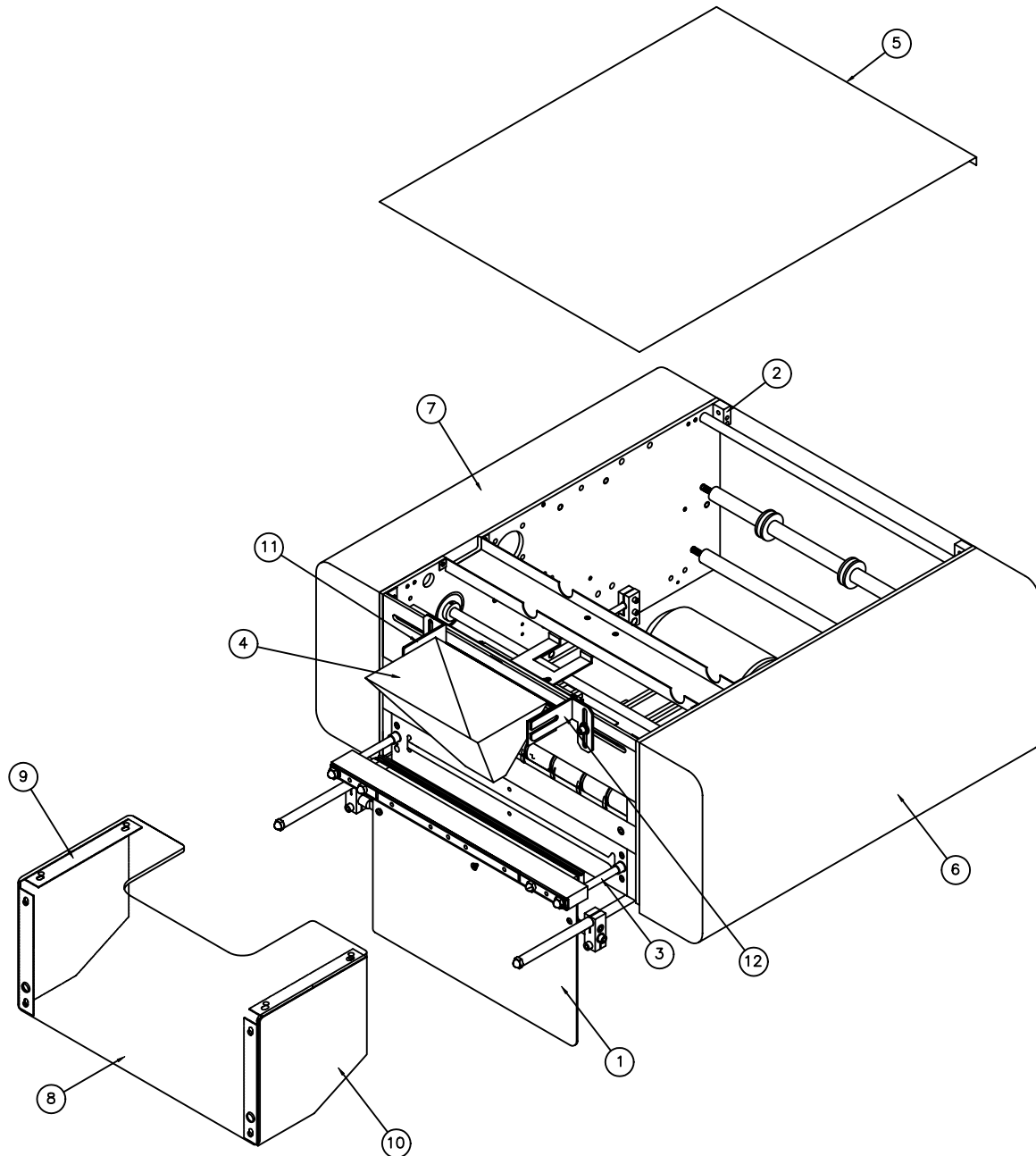
1	TA-T10018	Flat Load Shelf Sub-Assembly
2	TA-T10110	Main Frame Assembly, T-1000
3	TA-T10280	Sealer Frame Assembly S/F
4	TO-T1-FU-MISC	Additional Funnel for T-1000
5	TP-T1MD00044	Top Cover
6	TP-T1MD00045	Cover, Electronics Side
7	TP-T1MD00046	Cover, Pneumatics Side
8	TP-T1MD00116	Lexan Guard, T-1000
9	TP-T1MD00160-1	Lexan Cover Guard Bracket
10	TP-T1MD00160-2	Lexan Cover Guard Bracket
11	TP-T1MD00201-1	Funnel Mounting Bracket Left
12	TP-T1MD00201-2	Funnel Mounting Bracket Right

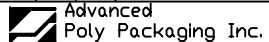

QUANTITY	—	REV	DATE	BY	DESCRIPTION
MATERIAL	—	 220 South Road • Akron • Ohio 44326 Phone: 330-728-2888 • Fax: 330-728-2889			
FINISH	—				
TOLERANCES UNLESS OTHERWISE NOTED +/- .005 ON FRACTIONAL DIMENSIONS +/- .001 ON TWO PLACE DECIMAL DIMENSIONS +/- .001 ON THREE PLACE DECIMAL DIMENSIONS .025 ✓ ON MACHINED SURFACES ALL DIMENSIONS ARE IN INCHES PART MUST BE FREE OF BURRS AND SHARP EDGES		TYPE EQUIPMENT <b>T-1000</b>	D/PN REF. NO. —	PART NO. —	
TITLE <b>HEAD ASSEMBLY</b>		SCALE <b>1:3.5</b>	DRAWN BY MELODY	APPROVED —	
DATE 11/22/01		DATE 11/22/01	DATE 11/22/01	DATE 11/22/01	
DRAWING NO. <b>TA-T10100</b>		REV. —			

NOTES: THIS DOCUMENT CONTAINS PROPRIETARY INFORMATION AND IT SHALL NOT BE USED OR REPRODUCED OR ITS CONTENTS DISCLOSED, IN WHOLE OR PART, WITHOUT THE PRIOR WRITTEN CONSENT OF ADVANCED POLY-PACKAGING INC.

## 5.3 Assembly => TA-T10018

### Flat Load Shelf Sub-Assembly

See Dwg #TA-T10018

1	TP-T1MB00074-1	Load Shelf Bracket (Left)
2	TP-T1MB00074-2	Load Shelf Bracket (Right)
3	TP-T1MB00075	Fixed Load Shelf 9" (Fixed)
4	TP-T1MB00076	Fixed Load Shelf Rod
5	TP-101102	Nut, 6-32 Hex Mach Screw
6	TP-102152	Washer, #6 Med Split Lock
7	TP-102155	Washer, 1/4 Med Split Lock
8	TP-103137	Screw, SHCS 1/4-20 x 1/2
9	TP-103224	Screw, BHCS 1/4-20 x 1/2
10	TP-103407	Screw, FHCS 6-32 x 3/4

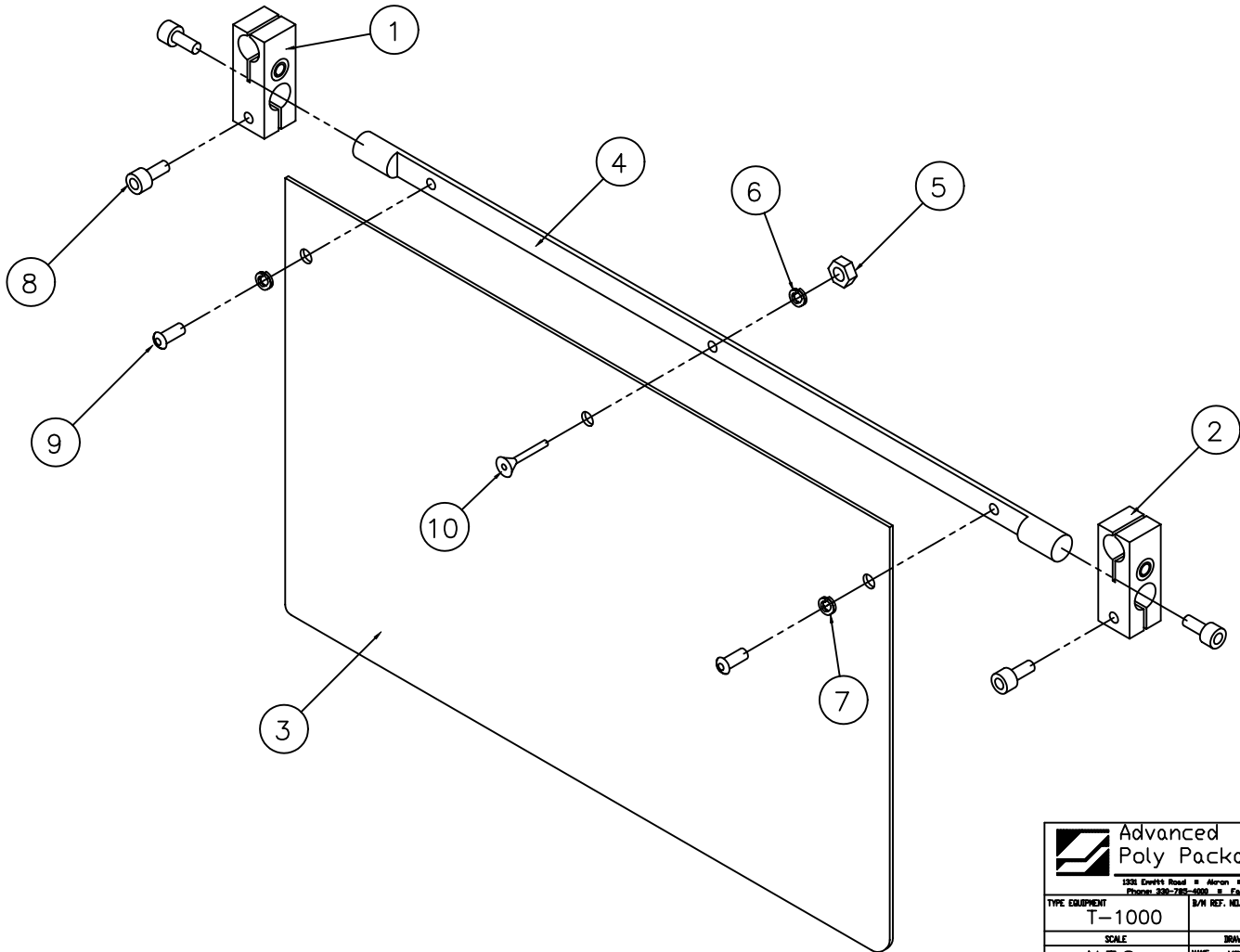

**Advanced Poly Packaging Inc.**  
 1231 Everett Road ■ Alton ■ Ohio 44326  
 Phone: 330-785-0000 ■ Fax: 330-785-5999

TYPE EQUIPMENT T-1000	B/M REF. NO.	PART NO.
SCALE N.T.S.	DRAWN BY NAME	APPROVED NAME
	DATE 7/28/00	DATE
TITLE FLAT LOAD SHELF SUB-ASSEMBLY		DRAWING NO. TA-T10018
NOTICE: THIS DOCUMENT CONTAINS PROPRIETARY INFORMATION AND IT SHALL NOT BE USED OR REPRODUCED OR ITS CONTENT DISCLOSED, IN WHOLE OR PART, WITHOUT THE PRIOR WRITTEN CONSENT OF ADVANCED POLY-PACKAGING INC.		REV.

## 5.4 Assembly => TA-T10110

### Main Frame Assembly, T-1000

See Dwg # TA-T10110

1	TA-T10230	Main Frame Assembly
2	TA-T10250	Inner Main Frame Assembly
3	TA-T10255	Outer Main Frame Assembly
4	TA-T10275	Electrical Panel Assembly



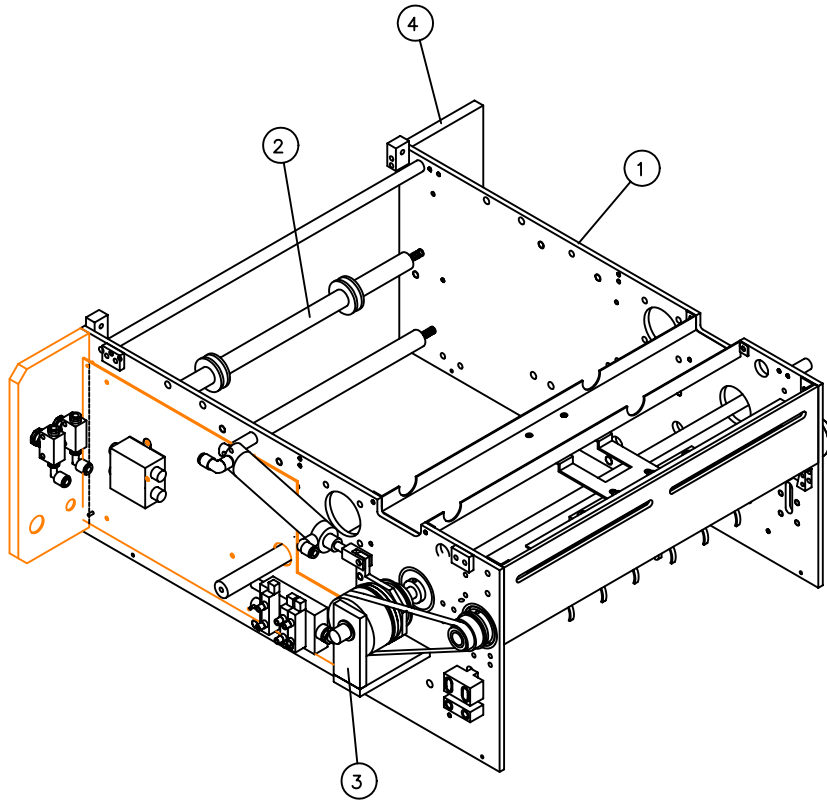

LEFT SIDE VIEW

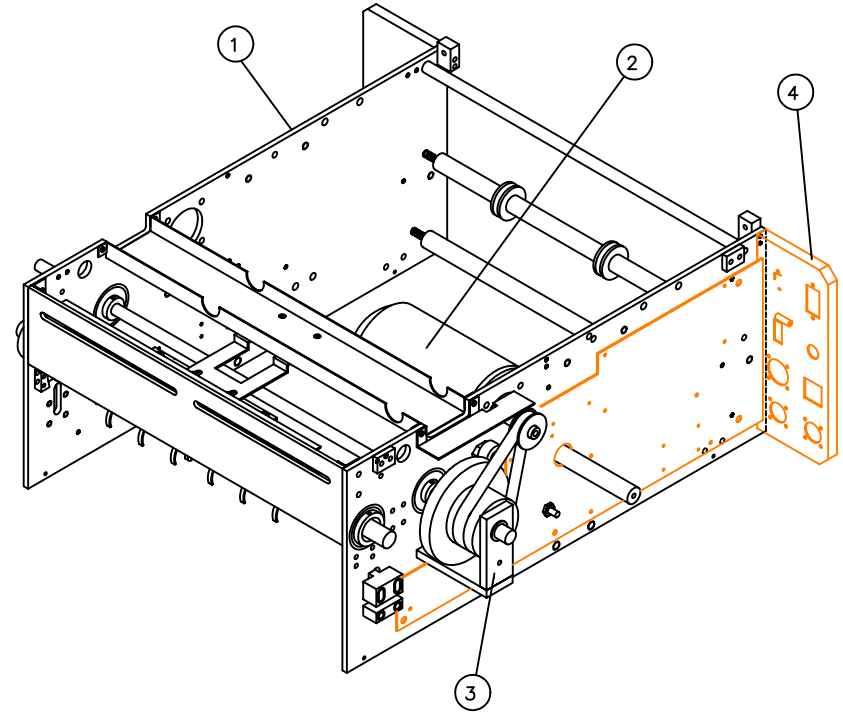

RIGHT SIDE VIEW

QUANTITY	—	REV	DATE	BY	DESCRIPTION
MATERIAL	—	 <b>Advanced Poly Packaging Inc.</b> <small>1331 Ewitt Road ■ Alton ■ Ohio 44306          Phone: 330-785-4000 ■ Fax: 330-785-4010</small>			
FINISH	—				
TOLERANCES UNLESS OTHERWISE NOTED: +/- .015 ON FRACTIONAL DIMENSIONS +/- .010 ON TWO PLACE DECIMAL DIMENSIONS +/- .003 ON THREE PLACE DECIMAL DIMENSIONS 125 ✓ ON MACHINED SURFACES ALL DIMENSIONS ARE IN INCHES PART MUST BE FREE OF BURRS AND SHARP EDGES		TYPE EQUIPMENT <b>T-1000</b>	B/M REF. NDL —	PART NDL —	
		SCALE <b>1:5</b>	DRAWN BY NAME <b>MELODY</b>	APPROVED NAME DATE <b>11/27/01</b>	
NOTICE: THIS DOCUMENT CONTAINS PROPRIETARY INFORMATION AND IT SHALL NOT BE USED OR REPRODUCED OR ITS CONTENT DISCLOSED, IN WHOLE OR PART, WITHOUT THE PRIOR WRITTEN CONSENT OF ADVANCED POLY-PACKAGING INC.		TITLE <b>MAIN FRAME ASSEMBLY</b>	DRAWING NDL <b>TA-T10110</b>	REV. —	

## 5.5 Assembly => TA-T10230

### Main Frame Assembly

See Dwg #TA-T10230

1	TP-T1MC00001-1	Main Frame Plate (left)
2	TP-T1MC00001-2	Main Frame Plate (right)
3	TP-T1MC00017	Vulcanized Rubber Roller
4	TP-T1MC00042	Face Plate
5	TP-T1MC00056	Belt Drive Rear Support Shelf
6	TP-T1MC00079	Shaft, Cylinder Pivot
7	TP-504113	Bearing, 7612 DLG (2/M)
8	TP-504114	Bearing, 7608 DLG

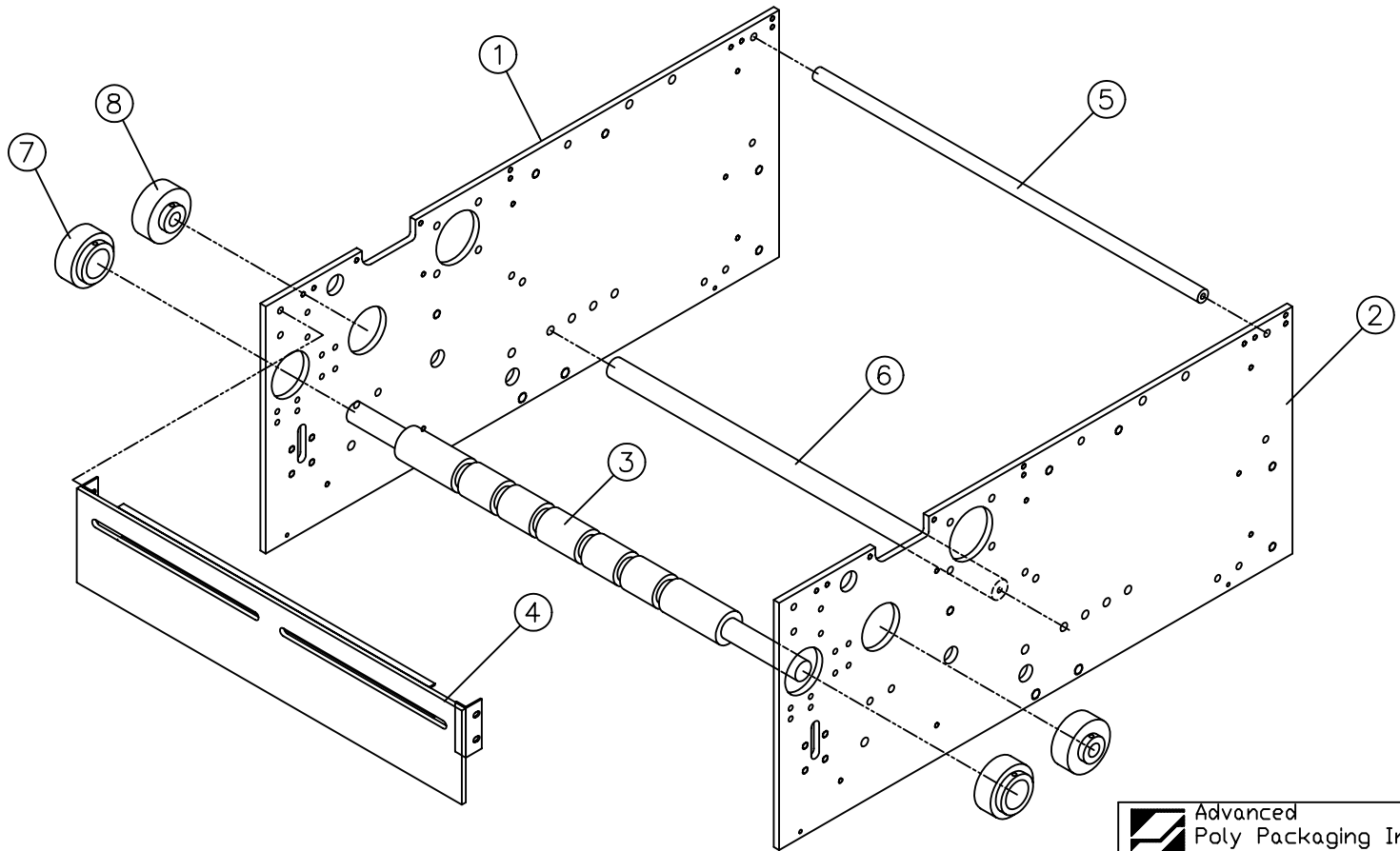

**Advanced Poly Packaging Inc.**  
 1231 Everett Road ■ Alton ■ Ohio 44306  
 Phone: 330-785-1000 ■ Fax: 330-785-5100

TYPE EQUIPMENT <b>T-1000</b>	B/M REF. NO.	PART NO.
SCALE <b>N.T.S.</b>	DRAWN BY <b>NAME</b>	APPROVED <b>NAME</b>
	DATE <b>7/19/00</b>	DATE
TITLE <b>MAIN FRAME ASSEMBLY</b>		DRAWING NO. <b>TA-T10230</b>
		REV.

NOTICE: THIS DOCUMENT CONTAINS PROPRIETARY INFORMATION AND IT SHALL NOT BE USED OR REPRODUCED OR ITS CONTENT DISCLOSED, IN WHOLE OR PART, WITHOUT THE PRIOR WRITTEN CONSENT OF ADVANCED POLY-PACKAGING INC.

## 5.6 Assembly => TA-T10250

### Inner Main Frame Assembly

See Dwg #TA-T10250

1	TA-T10001	Air Knife Assembly
2	TA-T10002	Upper Roller Finger Assembly
3	TP-T1MC00015	Support Brace Mtg. Block
4	TP-T1MC00052	Roller Guide
5	TP-T1MC00077	Shaft (Clutch & brake)
6	TP-T1MC00099	Rear Cover Support (2/M)
7	TP-T1MC00103	Wiring Channel
8	TP-T1MC00163-1	Seal Frame Guide Block-LH
9	TP-T1MC00163-2	Seal Frame Guide Block-RH
10	TP-T1ME00302	High Voltage Cable
11	TP-106106	Spring Pins, SS 1/4 x 1-1/4
12	TP-108099	Compression Spring, Guide
13	TP-111010	Collars, Spring Closure
14	TP-111142	Clamp Collar, 2 pc Split
15	TP-214373	Clamp, 1/4" #10 Screw
16	TP-401291	Elbow, 1/4" Tube X 1/4" Tube
17	TP-406181	Filter, 4 micron (air knife)
18	TP-501127	Motor 1/9 HP 1700 RPM 115
19	TP-501130	Capacitor, (T-1000 Motor)

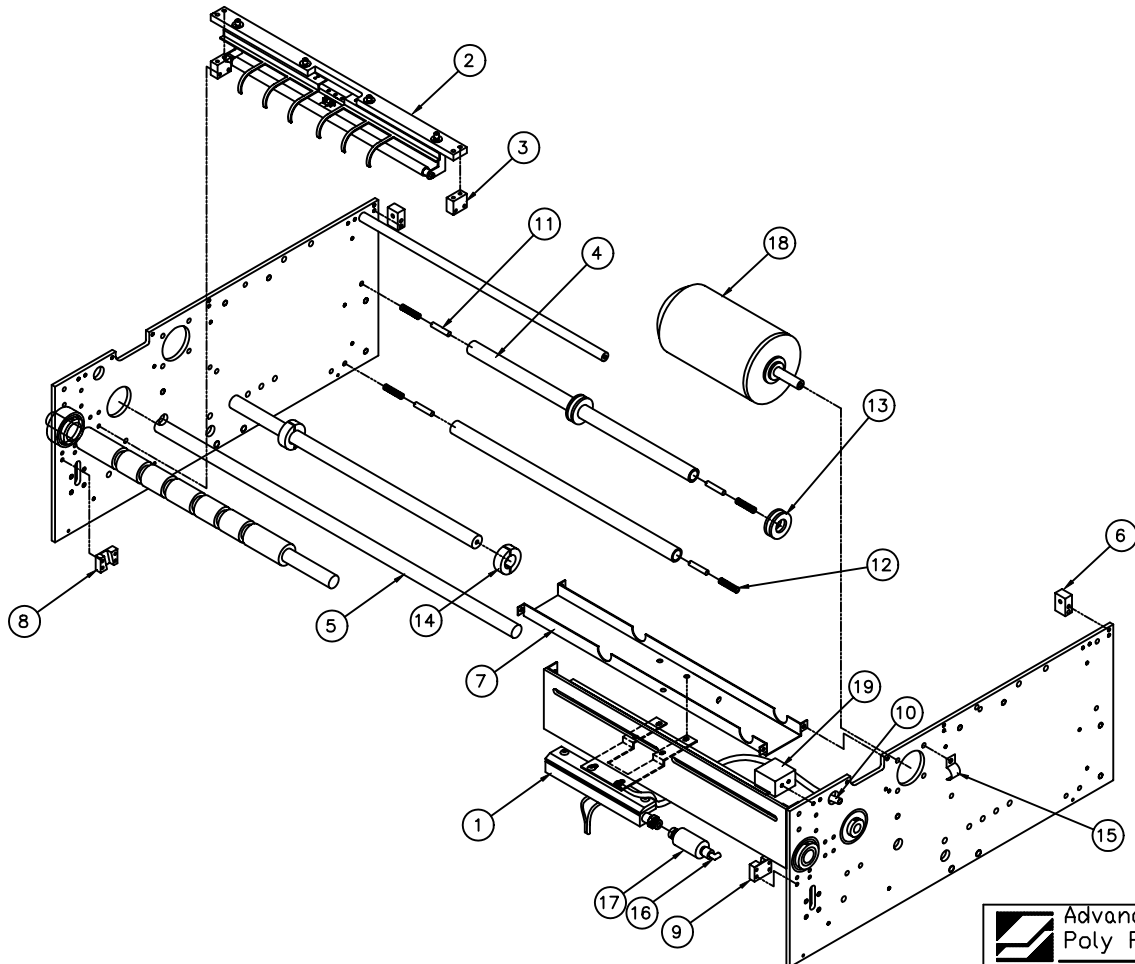

**Advanced Poly Packaging Inc.**  
 1201 Everett Road ■ Alton ■ Ohio 44326  
 Phone: 330-785-4000 ■ Fax: 330-785-4100

TYPE EQUIPMENT T-1000	B/M REF. NO.	PART NO.
SCALE N.T.S.	DRAWN BY NAME DATE 7/20/00	APPROVED NAME DATE
TITLE INNER MAIN FRAME ASSEMBLY		DRAWING NO. TA-T10250
NOTICE: THIS DOCUMENT CONTAINS PROPRIETARY INFORMATION AND IT SHALL NOT BE USED OR REPRODUCED OR ITS CONTENT DISCLOSED, IN WHOLE OR PART, WITHOUT THE PRIOR WRITTEN CONSENT OF ADVANCED POLY-PACKAGING INC.		REV.

## 5.7 Assembly => TA-T10002

### Upper Roller Finger Assembly

See Dwg# TA-T10002

1	TP-T1MC00014	Support Brace (Sensor)
2	TP-T1MC00020-1	Upper Finger (Left)
3	TP-T1MC00020-2	Upper Finger (Right)
4	TP-T1MC00083	Insulator, High Volt Sensor
5	TP-T1MC00118-1	Film Web Roller Bracket (Left)
6	TP-T1MC00118-2	Film Web Roller Bracket (Right)
7	TP-T1MC00119	Film Web Roller
8	TP-T1MC00120	Film Web Roller Shaft
9	TP-102134	Washer, #10 SAE Flat Zinc
10	TP-102152	Washer, #6 Med Split Lock
11	TP-102153	Washer, #8 Med Split Lock
12	TP-102154	Washer, #10 Med Split Lock
13	TP-103015	Screw, SHCS 8-32 x 3/8
14	TP-103129	Screw, SHCS 10-32 x 1/2 BLK
15	TP-103132	Screw, SHCS 10-32 x 1 BLK
16	TP-103209	Screw, BHCS 6-32 x 3/4
17	TP-104129	Spacer, 3/8" OD x 1/4" Long
18	TP-107177	Bushing, 1/4ID x 3/8OD
19	TA-T100124-1	High Voltage Sensor
20	TP-101140	#6-32 Hex Nylon Insert Lock

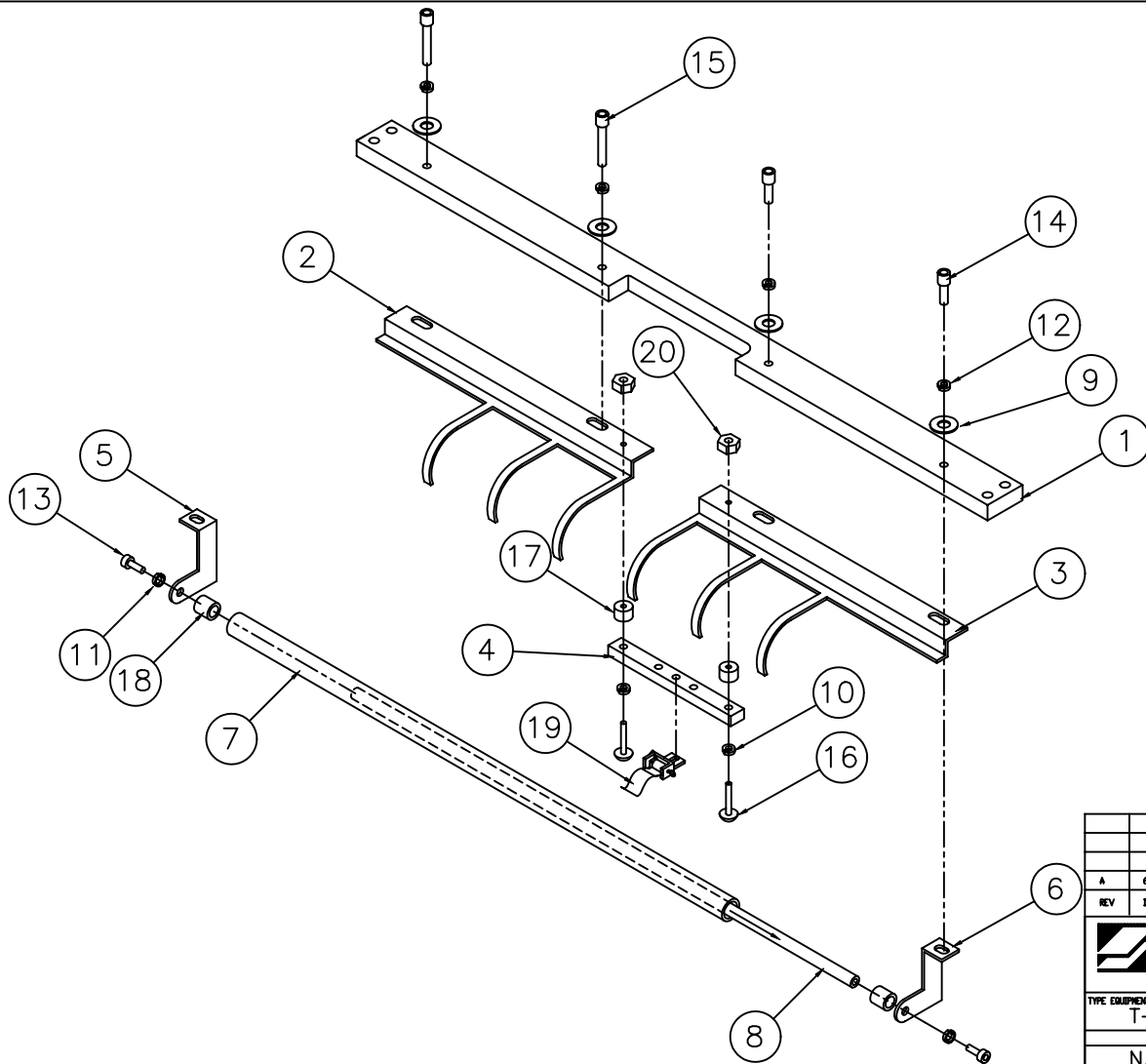

A	6/25/01	MJD	ADDED 6-32 NYLON LOCK NUTS
REV	DATE	BY	DESCRIPTION
 <b>Advanced Poly Packaging Inc.</b> <small>1331 Everett Road • Alton • Ohio 44396          Phone: 330-785-0000 • Fax: 330-785-5000</small>			
TYPE EQUIPMENT T-1000		B/M REF. NO.	PART NO.
SCALE N.T.S.		DRAWN BY	APPROVED
		NAME	MELODY
		DATE	7/17/00
TITLE UPPER ROLLER FINGER ASSEMBLY			DRAWING NO. TA-T10002
			REV. A

NOTICE: THIS DOCUMENT CONTAINS PROPRIETARY INFORMATION AND IT SHALL NOT BE USED OR REPRODUCED OR ITS CONTENT DISCLOSED, IN WHOLE OR PART, WITHOUT THE PRIOR WRITTEN CONSENT OF ADVANCED POLY-PACKAGING INC.

## 5.8 Assembly => TA-T10001

### Air Knife Assembly

See Dwg# TA-T10001

1	TP-T1MC00080	Venturi / Air Pulse Bracket
2	TP-T1MC00108	Air Pulse Manifold Assembly
3	TP-102154	Washer, #10 Med Split Lock
4	TP-103129	Screw, SHCS 10-32 x 1/2
5	TP-401134	Hex Plug, 1/8"x 3/4 Brass
6	TP-401258	Straight, 1/4" Tube x 1/8
7	TP-401292	Straight 1/4 poly x 1/4 np
8	TP-405268	Air knife (Venturi) 6"



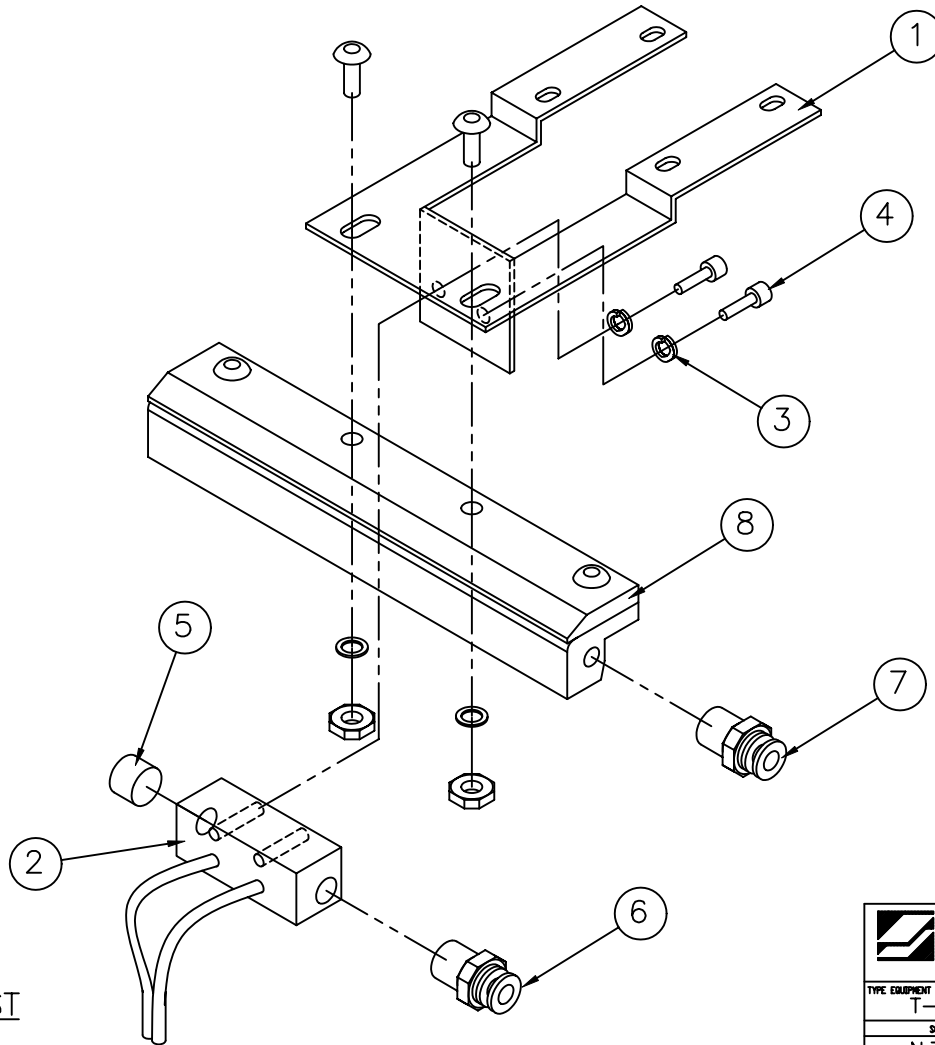

NOTE:  
 ALL FITTINGS MUST  
 HAVE TEFLON TAPE

 <b>Advanced Poly Packaging Inc.</b> <small>1231 Everett Road • Alton • Ohio 44396          Phone: 330-795-1000 • Fax: 330-795-1010</small>			
TYPE EQUIPMENT	B/M REF. NO.	PART NO.	
T-1000			
SCALE	DRAWN BY	APPROVED	
N.T.S.	NAME	MELODY	NAME
	DATE	7/14/00	DATE
TITLE		DRAWING NO.	REV.
AIR KNIFE ASSEMBLY		TA-T10001	

NOTICE: THIS DOCUMENT CONTAINS PROPRIETARY INFORMATION AND IT SHALL NOT BE USED OR REPRODUCED OR ITS CONTENT DISCLOSED, IN WHOLE OR PART, WITHOUT THE PRIOR WRITTEN CONSENT OF ADVANCED POLY-PACKAGING INC.

## 5.9 Assembly => TA-T10255

### Outer Main Frame Assembly

See Dwg# TA-T10255

1	TA-T10025	Pneumatic Mntg. Valve Assembly
2	TA-T10702	Clutch-Timing Belt Pulley
3	TA-T10703	Tear Off Clutch Assembly
4	TP-T1MC00054	Cover Support Clamp (4/M)
5	TP-T1MC00058	Latch Adjuster Block (2/M)
6	TP-T1MC00059	Latch Lock Block (2/M)
7	TP-T1MC00082	Cover Stand-off (2/M)
8	TP-T1MC00084	Clutch Bearing Support
9	TP-T1MC00085	Support Block
10	TP-T1MC00091	Bracket, Belt Tensioner
11	TP-T1MC00097	Cylinder Standoff
12	TP-T1MC00114	Pulley, Roller/Brake
13	TP-T1MC00161	Pulley, Brake
14	TP-T1MC00162	Pulley, Motor
15	TP-T1MC00176	Belt Shroud (Right Hand)
16	TP-T1MD00153	Pneumatics Mtg Panel Assembly
17	TP-107121	Bushing, Flange 1/2ID X 5/
18	TP-205108	Filter, 120/250VAC 50/60 HZ
19	TP-215200	Switch, Magnetic (Threaded)
20	TP-401258	Straight, 1/4" Tube x 1/8
21	TP-402107	Flow Control Valve (panel)
22	TP-402187	Flow Control (Flat Seal & Assembly)
23	TP-403243	Cylinder, 1.06" Bore x 3"
24	TP-404251	Rod Clevis 1.06" Bore Size
25	TP-503102	Belt, Brake
26	TP-503182	Belt, Clutch
27	TP-504132	Cam Follower

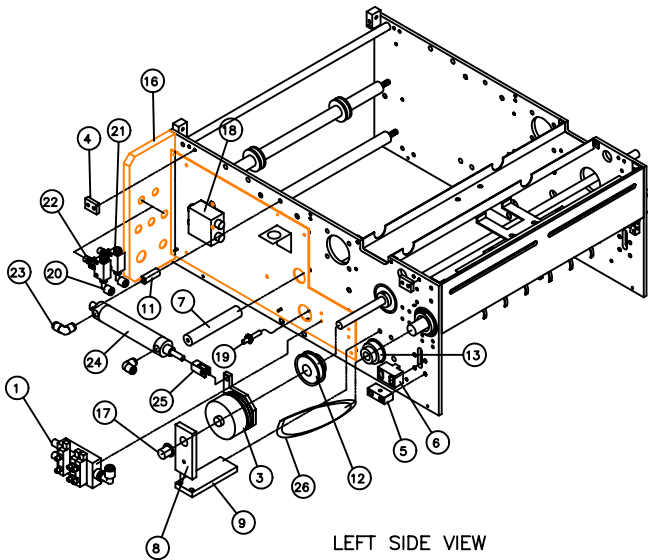

LEFT SIDE VIEW

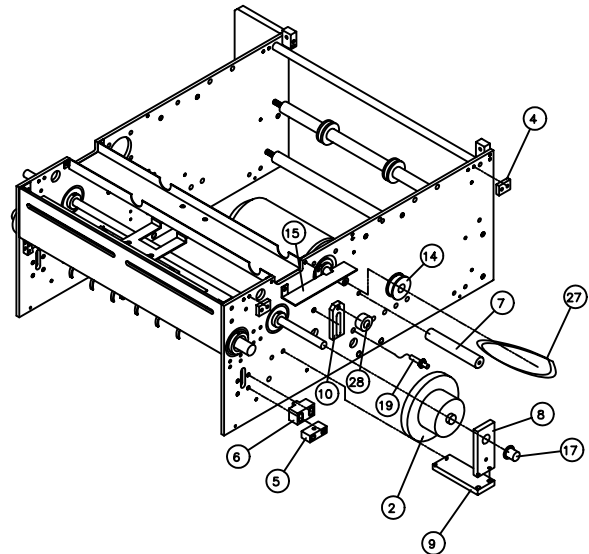

RIGHT SIDE VIEW

QUANTITY	—
MATERIAL	—
FINISH	—
<p><b>TOLERANCES UNLESS OTHERWISE NOTED:</b>            +/- .015 ON FRACTIONAL DIMENSIONS            +/- .010 ON TWO PLACE DECIMAL DIMENSIONS            +/- .003 ON THREE PLACE DECIMAL DIMENSIONS            .125 ON MACHINED SURFACES            ALL DIMENSIONS ARE IN INCHES            PART MUST BE FREE OF BURRS AND SHARP EDGES</p>	

NOTICE: THIS DOCUMENT CONTAINS PROPRIETARY INFORMATION AND IT SHALL NOT BE USED OR REPRODUCED OR ITS CONTENT DISCLOSED, IN WHOLE OR PART, WITHOUT THE PRIOR WRITTEN CONSENT OF ADVANCED POLY-PACKAGING INC.

REV	DATE	BY	DESCRIPTION
 <b>Advanced Poly Packaging Inc.</b> <small>1201 Everett Road ■ Alton ■ Ohio 44306          Phone: 330-785-0000 ■ Fax: 330-785-5100</small>			
TYPE EQUIPMENT T-1000		B/M REF. NO.	PART NO.
SCALE 1:6		DRAWN BY	APPROVED
		NAME	MELODY
		DATE	7/24/00
TITLE OUTER MAIN FRAME ASSEMBLY			DRAWING NO. TA-T10255
			REV. —

## 5.10 Assembly => TA-T10025

### Pneumatic Mounting Valve Assembly

See Dwg# TA-T10025

1	TP-401134	Hex Plug, 1/8"x 3/4 Brass
2	TP-401275	Elbow, 3/8" tube x 1/8" np
3	TP-401288	2 Pin SY S.ValveCon.Housin
4	TP-402252	5 Station Manifolds Assembly
5	TP-404262	Muffler, Sintered Bronze 1

## 5.11 Assembly => TA-T10275

### Electrical Panel Assembly

See Dwg# TA-T10275

1	TC-T1-HARNESS	Wiring Harness, T-1000
2	TP-T1MD00113	Electronics Back Plate
3	TP-T1MD00149	Electronics Mtg Panel Assembly
4	TP-T1ME00301	PCB, High Voltage Board Figure
5	TP-200348	PCB, T-1000 IF Bd. Comp.
6	TP-202116	6,000uF 40V Comp Capacitor
7	TP-206146	Triac, 400v, 25amp, Q4025P
8	TP-207216	Fuse Holder(110v/220v)
9	TP-211384	Transformer, High Volt W/RF
10	TP-211391	Triad Dual Pri. Transformer
11	TP-212166	6 pin circular Male Conn
12	TP-212167	6 pin Circular Fem Conn
13	TP-212247	9 pin D-sub female (solder)
14	TP-212338	10 pin circular Fem Conn
15	TP-212342	Terminal, Fem.Insul 12-10(5)
16	TP-212400	Receptacle, Black
17	TP-214270	Standoff, 2"Round Alum 6-32
18	TP-214273	Standoff, Nylon Hex Threader
19	TP-215383	Switch, 250V@10A
20	TP-220367	PLC, T-1000
21	TP-203010	IC, 27C256 32K x 8 (256K)

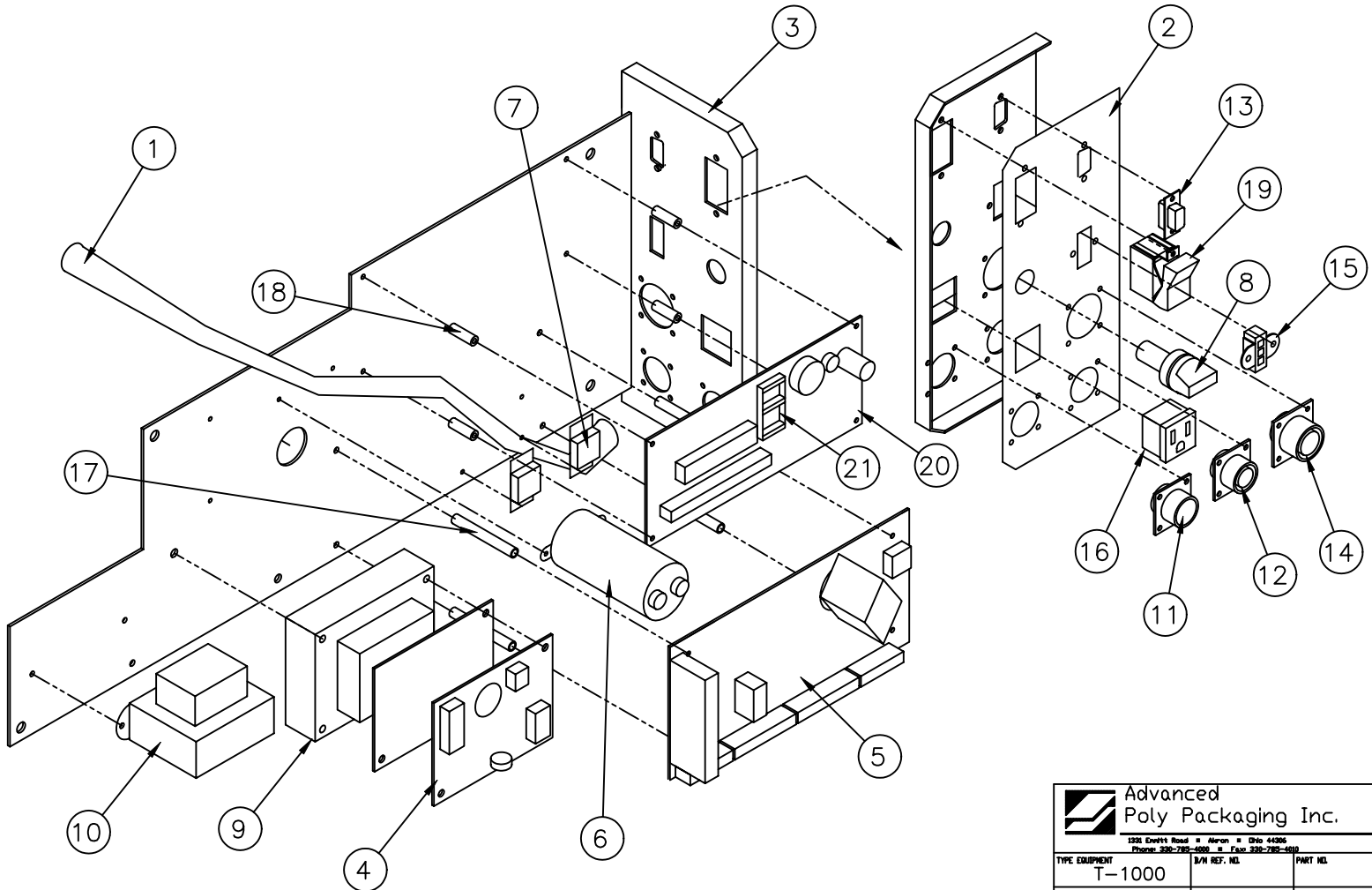

**Advanced Poly Packaging Inc.**  
 1234 Elm St Road • Alton • Ohio 44305  
 Phone: 330-785-1000 • Fax: 330-785-1010

TYPE EQUIPMENT	B/M REF. NO.	PART NO.
T-1000		
SCALE	DRAWN BY	APPROVED
N.T.S.	NAME	MELODY
	DATE	8/2/00
TITLE		REV.
ELECTRICAL PANEL ASSEMBLY		
DRAWING NO.		
TA-T10275		

NOTICE: THIS DOCUMENT CONTAINS PROPRIETARY INFORMATION AND IT SHALL NOT BE USED OR REPRODUCED OR ITS CONTENT DISCLOSED, IN WHOLE OR PART, WITHOUT THE PRIOR WRITTEN CONSENT OF ADVANCED POLY-PACKAGING INC.

## 5.12 Assembly => TA-T10280

### Sealer Frame Assembly (Standard Frame)

See Dwg# TA-T10280

1	TA-T10003	Seal Frame Manifold Sub-Assembly
2	TA-T10004	Main Seal Cylinder Sub-Assembly
3	TA-T10005	Pressure Bar Sub-Assembly
4	TA-T10006	Heater Bar Sub-Assembly
5	TA-T10009	PTFE Anti-Stick Guide Sub-Assembly
6	TA-T10012	Grooved Roller Mounting Sub-Assembly
7	TA-T10013	Heater Bar Cylinder Sub-Assembly
8	TA-T10017	Bag Finger Grounding Assembly
9	TA-T10019	Latch Sub-Assembly
10	TP-T1MB00005	Gripper Plate (Standard)
11	TP-T1MB00010	Seal Rod Tie
12	TP-T1MB00016	Seal Cylinder Mtg Block
13	TP-T1MB00022	Guard Rod Mounting Block
14	TP-T1MB00026	Gripper Plate Spacer
15	TP-T1MB00033	Seal Rod (2/M)
16	TP-T1MB00041	Main Seal Cylinder Cushion
17	TP-T1MB00057	Heater Bar Yoke (2/M)
18	TP-T1MB00062	Latch Handle
19	TP-T1MB00063	Latch Shaft
20	TP-T1MB00107	Magnetic Sensor Housing
21	TP-T1MB00144	Shield Mounting Rods (2/M)
22	TP-T1MB00164	Pivot Clamp
23	TP-T1MB00200	Sealer Frame Machined
24	TP-T1ME00209	Seal Bar Coiled Cable Harness
25	TP-101123	Nut, Hex Jam Zinc 3/8-16
26	TP-101132	Nut, Acorn Steel Zinc Pltd
27	TP-101133	Nut, Acorn Zinc Pltd 3/8-1
28	TP-102103	Lockwasher, #8 Int Tooth Pltd
29	TP-102105	Lockwasher, Int Tooth Pltd
30	TP-102106	Lockwasher, Int Tooth Pltd
31	TP-102133	Washer,#8 SAE Flat Zinc
32	TP-102143	Washer, SAE Flat Zinc 5/16
33	TP-102144	Washer, SAE Flat Zinc 3/8
34	TP-102154	Washer, #10 Med Split Lock
35	TP-102155	Washer, 1/4 Med Split Lock
36	TP-102254	Washer, Fender 3/8 x 1-1/2
37	TP-103006	Screw, SHCS 3/8-24 x 3/4
38	TP-103014	Screw, SHCS 10-32 x 1-3/4
39	TP-103116	Screw, SHCS 8-32 x 1/2
40	TP-103129	Screw, SHCS 10-32 x 1/2 BLK
41	TP-103137	Screw, SHCS 1/4-20 x 1/2
42	TP-103139	Screw, SHCS 1/4-20 x 3/4
43	TP-103140	Screw, SHCS 1/4-20 x 1
44	TP-103141	Screw, SHCS 1/4-20 x 1-1/4
45	TP-103142	Screw, SHCS 1/4-20 x 1-1/2
46	TP-103186	Screw, Shoulder
47	TP-103210	Screw, BHCS 8-32 x 1/4 BLK
48	TP-103225	Screw, BHCS 1/4-20 x 3/4
49	TP-103261	Set-screw, 10-32 x 1/4
50	TP-106109	Spring Pins, SS 1/8 x 3/4
51	TP-106110	Spring Pins, SS 1/8 x 1/2
52	TP-107160	Bushing,PTFE Coated
53	TP-107227	Bushing,Thrust Nylon 1/2ID
54	TP-107228	Bushing,Nylon Flange 3/8ID
55	TP-211374	Magnets
56	TP-214373	Clamp, 1/4" #10 Screw
57	TP-401254	Union Tee Fitting, 1/4" Tube

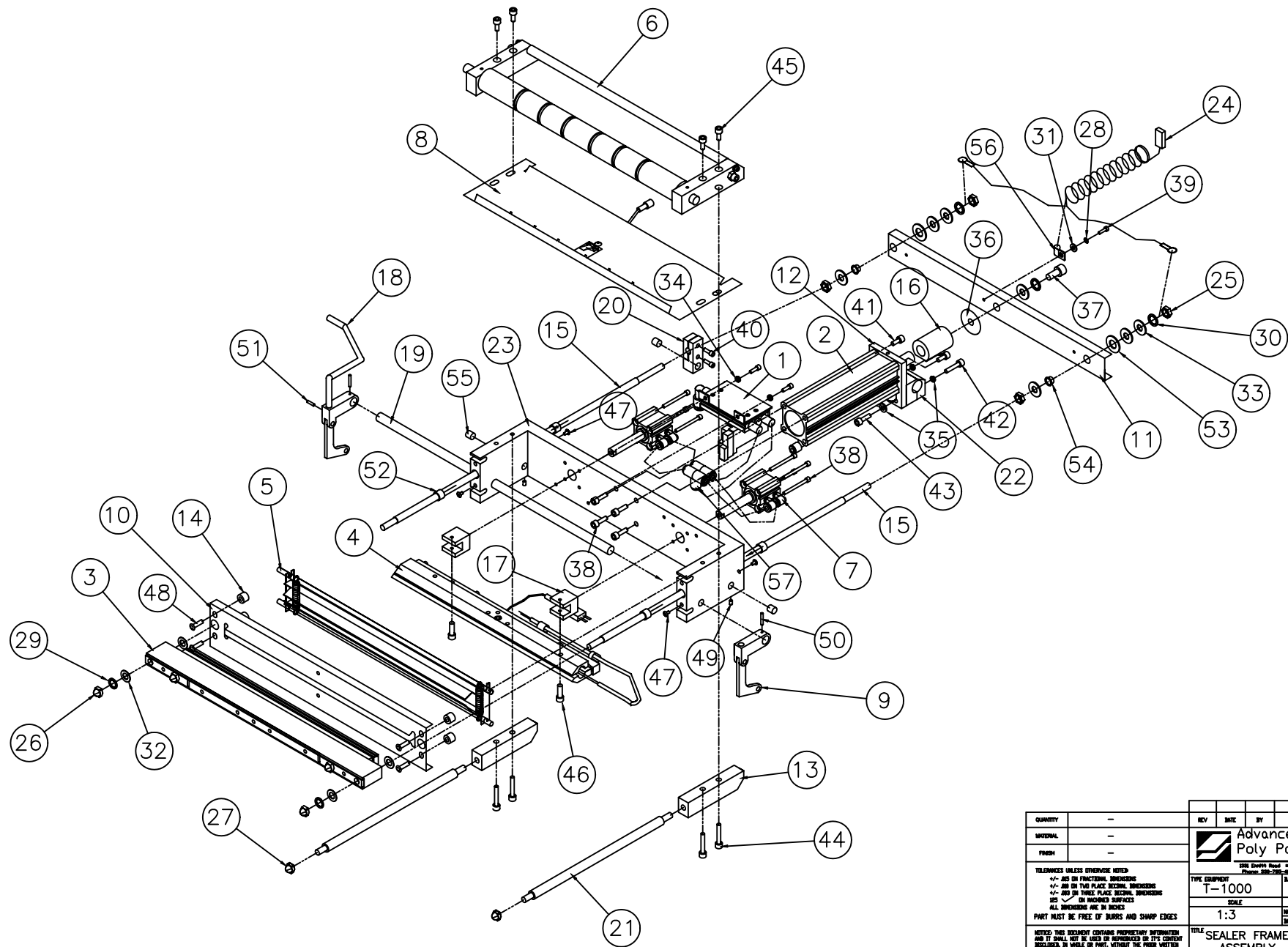

QUANTITY	-	REV	DATE	BY	DESCRIPTION
MATERIAL	-	Advanced Poly Packaging Inc.			
FINISH	-	 Advanced Poly Packaging Inc. <small>528 South Road • Akron • Ohio 44308          Phone: 216-752-2800 • Fax: 216-752-2809</small>			
TOLERANCES UNLESS OTHERWISE NOTED		TYPE EQUIPMENT	S/N REF. NO.	PART NO.	
+/- .005 ON FRACTIONAL DIMENSIONS		T-1000		-	
+/- .001 ON TWO PLACE DECIMAL DIMENSIONS		SCALE	DRAWN BY	APPROVED	
+/- .001 ON THREE PLACE DECIMAL DIMENSIONS		1:3	NAME	DATE	DATE
.005 ON FINISHED SURFACES			MELODY	7/28/00	
ALL DIMENSIONS ARE IN INCHES			DATE	DATE	DATE
PART MUST BE FREE OF BURRS AND SHARP EDGES		TITLE SEALER FRAME ASSEMBLY		DRAWING NO.	REV.
NOTED: THIS DOCUMENT CONTAINS PROPRIETARY INFORMATION AND IT SHALL NOT BE USED OR REPRODUCED OR ITS CONTENTS DISCLOSED, IN WHOLE OR PART, WITHOUT THE PRIOR WRITTEN CONSENT OF ADVANCED POLY-PACKAGING, INC.				TA-T10280	-



## 5.13 Assembly => TA-T10003

### Seal Frame Manifold Sub-Assembly

See Dwg# TA-T10003

1	TP-T1MB00021	Valve Manifold Mtg Bracket
2	TP-101103	Nut,8-32 Hex Mach Screw Plate
3	TP-102103	Lockwasher,#8 Int Tooth Plate
4	TP-103118	Screw, SHCS 8-32 x 1
5	TP-401134	Hex Plug,1/8"x 3/4 Brass
6	TP-401275	Elbow, 3/8" tube x 1/8" np
7	TP-401288	2 Pin SY S.ValveCon.Housin
8	TP-402253	5 Station Valve Manifold
9	TP-404262	Muffler, Sintered Bronze 1

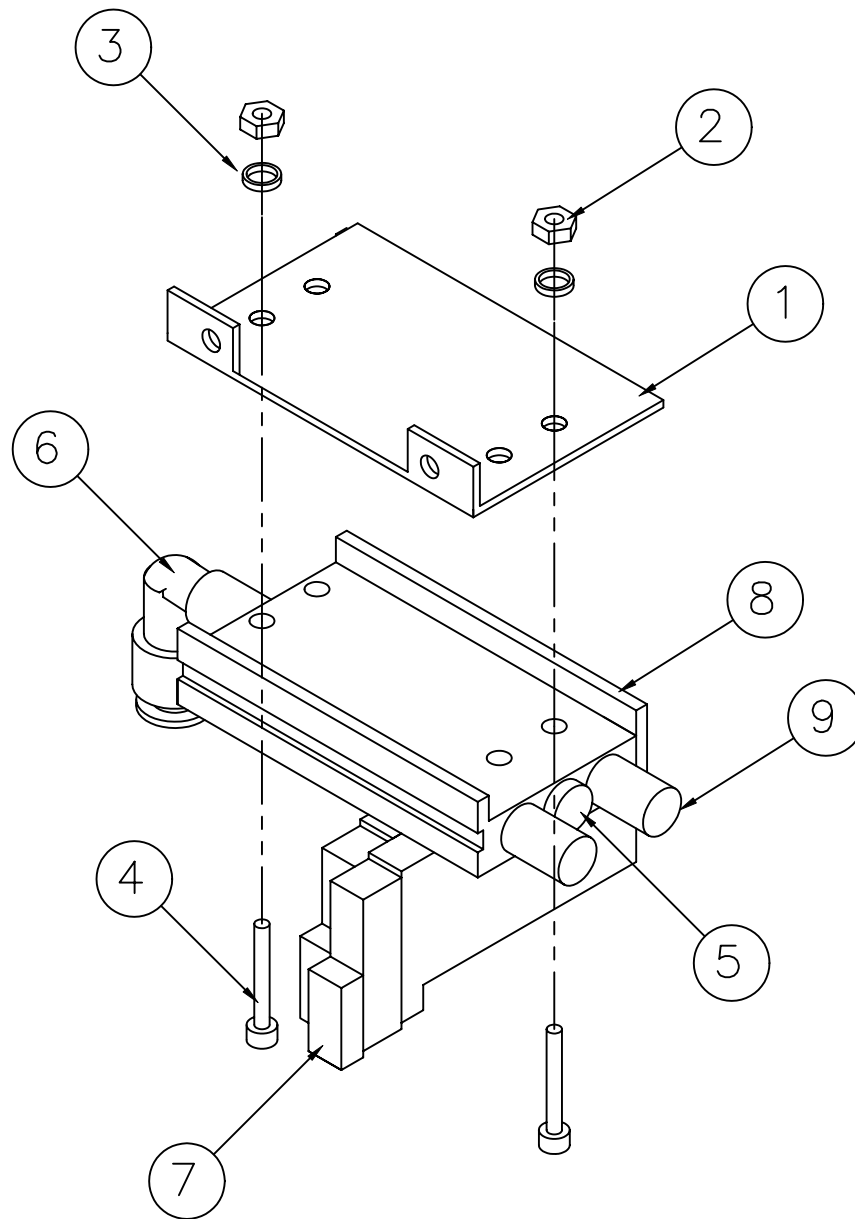

NOTE:  
 ALL FITTINGS MUST  
 HAVE TEFLON TAPE.

 <b>Advanced Poly Packaging Inc.</b> <small>1331 Enright Road ■ Akron ■ Ohio 44306          Phone: 330-785-4000 ■ Fax: 330-785-4010</small>			
TYPE EQUIPMENT T-1000	B/W REF. NDL	PART NDL	
SCALE N.T.S	NAME MELODY	DATE 7/18/00	APPROVED NAME DATE
TITLE SEAL FRAME MANIFOLD SUB-ASSEMBLY		DRAWING NDL TA-T10003	REV.

NOTICE: THIS DOCUMENT CONTAINS PROPRIETARY INFORMATION AND IT SHALL NOT BE USED OR REPRODUCED OR ITS CONTENT DISCLOSED, IN WHOLE OR PART, WITHOUT THE PRIOR WRITTEN CONSENT OF ADVANCED POLY-PACKAGING INC.

## 5.14 Assembly => TA-T10005

### Pressure Bar Sub-Assembly

See Dwg# TA-T10005

1	TP-T1MB00029	Anti-Jam Pressure Housing
2	TP-T1MB00030	Anti-jam Contact Center
3	TP-T1MB00031	Anti-jam Pressure Pad
4	TP-T1MB00068	Anti-jam Contact Strip
5	TP-T1MB00111	Rubber Strip Holder
6	TP-101131	Nut, Acorn Brass Nickel Plate
7	TP-103138	Screw, SHCS 1/4-20 x 5/8
8	TP-103408	Screw, FHCS 8-32 x 3/8
9	TP-106093	Stud, 1/4-20 x 2.0" (Anti-jam)
10	TP-108155	Compression Spring, Pressure
11	TP-306002	Anti-jam Seal Bar Rubber

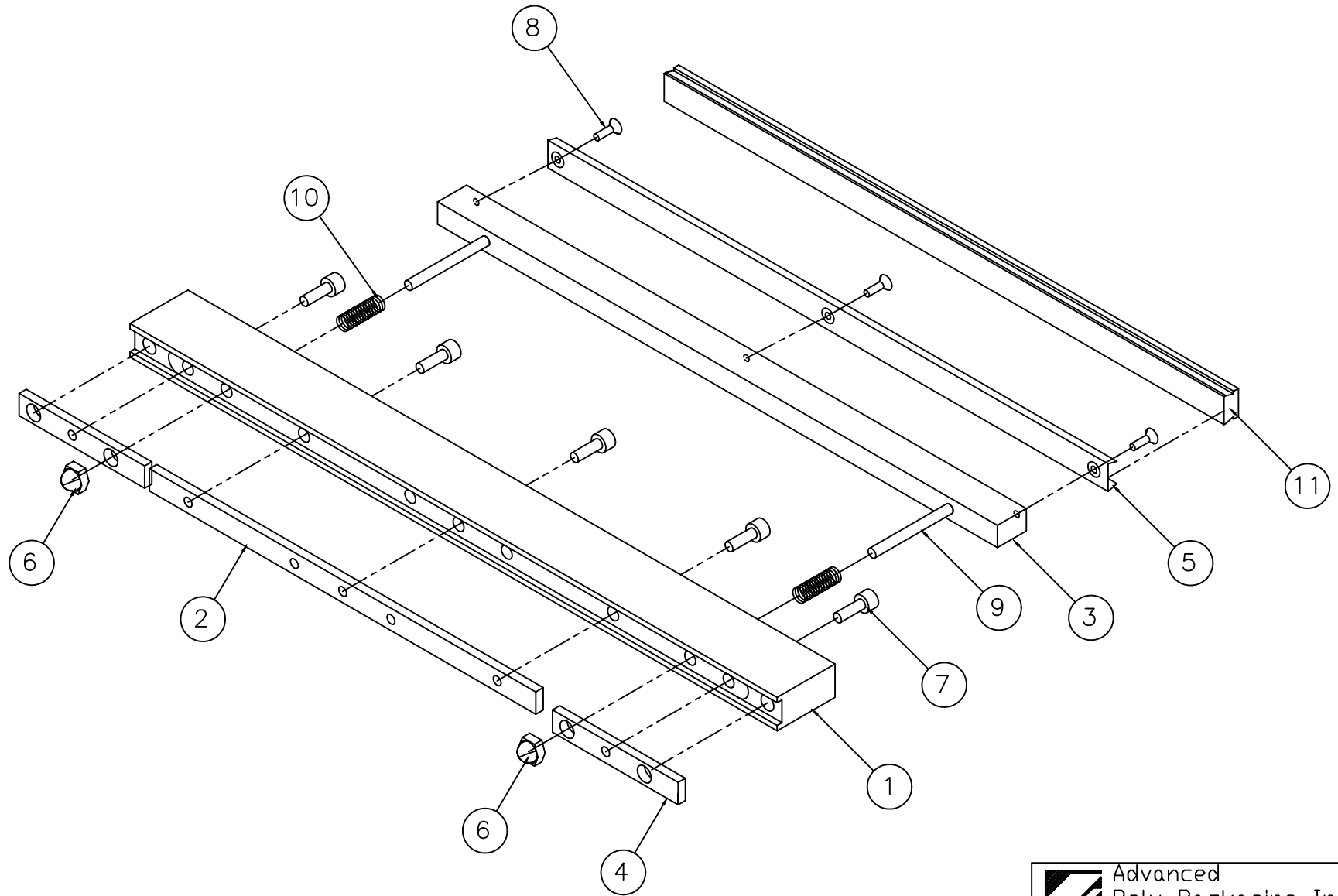

 <b>Advanced Poly Packaging Inc.</b> <small>1331 Enwitt Road ■ Akron ■ Ohio 44306          Phone: 330-785-4000 ■ Fax: 330-785-4010</small>		
TYPE EQUIPMENT T-1000	B/M REF. NDL	PART NDL
SCALE N.T.S.	DRAWN BY NAME MELODY DATE 7/25/00	APPROVED NAME DATE
TITLE PRESSURE BAR SUB-ASSEMBLY		DRAWING NDL TA-T10005
NOTICE: THIS DOCUMENT CONTAINS PROPRIETARY INFORMATION AND IT SHALL NOT BE USED OR REPRODUCED OR ITS CONTENT DISCLOSED, IN WHOLE OR PART, WITHOUT THE PRIOR WRITTEN CONSENT OF ADVANCED POLY-PACKAGING INC.		REV.

## 5.15 Assembly => TA-T10006

### Heater Bar Sub-Assembly

See Dwg# TA-T10006

1	TP-T1MB00008	Heater Bar Mtg Plate
2	TP-T1MB00009	Heater Seal Bar
3	TP-T1MB00024	Heater Cartridge Bracket
4	TP-T1MB00145	Thermocouple Wire Tie Down
5	TP-T1MB00159	Heater Cartridge Wire Lead
6	TP-101126	Nut, Hex Jam SS 10-32
7	TP-102150	Washer, #10 Flat SS
8	TP-103025	Screw, SHCS 10-32 x 1 SS
9	TP-103242	Screw, BHCS SS 10-32 x 3/8
10	TP-103248	Screw, BHCS SS 10-32 x 1
11	TP-104124	Spacer, Round Unthreaded
12	TP-217116	Cartridge, Heater 800W 120
13	TP-221416	Thermal-Couple Wire w/ Conn

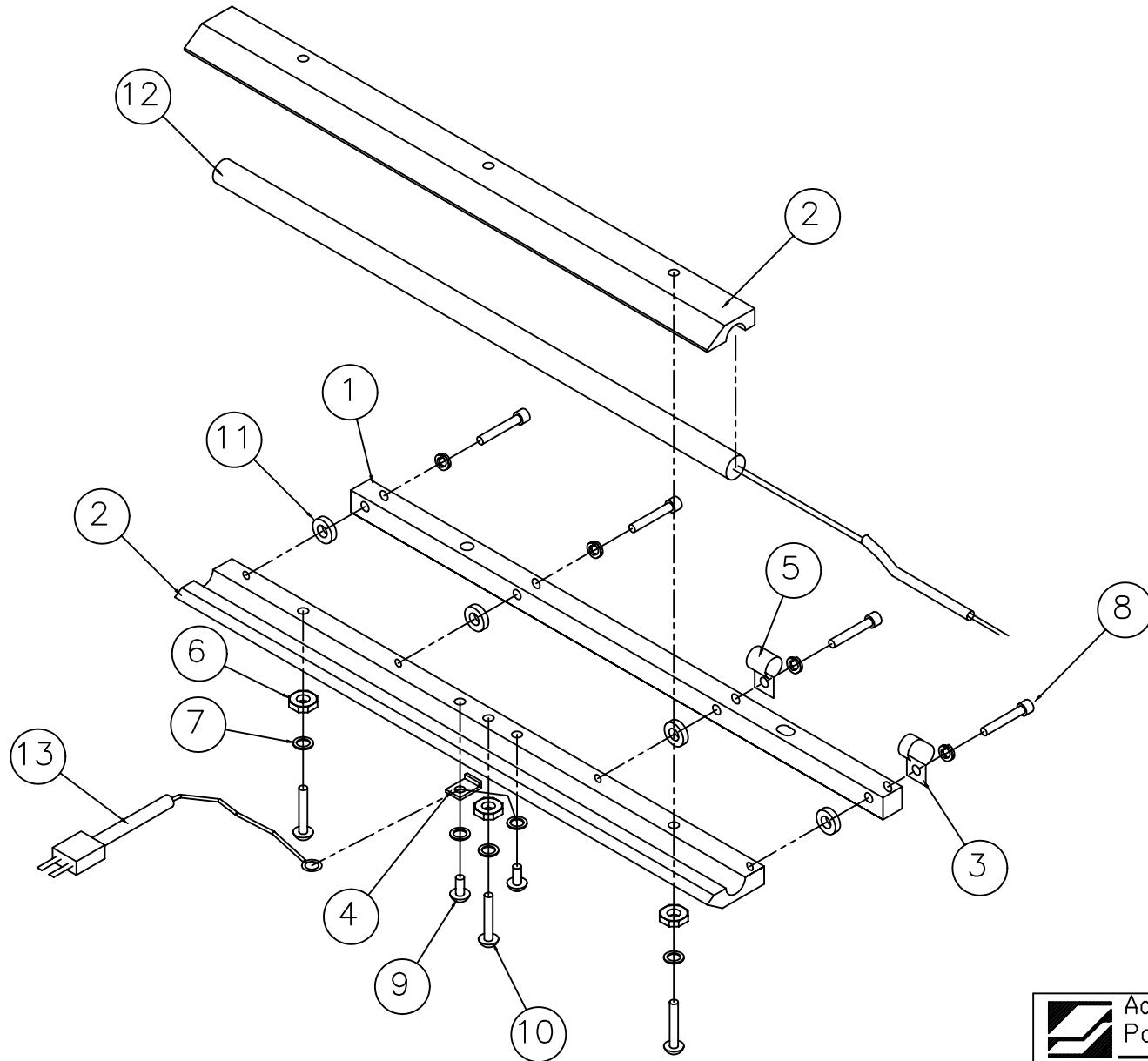

 <b>Advanced Poly Packaging Inc.</b> <small>1331 E. 9th Road # Akron # Ohio 44306          Phone: 330-785-4000 # Fax: 330-785-4010</small>		
TYPE EQUIPMENT T-1000	B/W REF. NDL	PART NDL
SCALE N.T.S.	DRAWN BY NAME MELODY DATE 7/26/00	APPROVED NAME DATE
TITLE HEATER BAR SUB-ASSEMBLY		DRAWING NDL TA-T10006
NOTICE: THIS DOCUMENT CONTAINS PROPRIETARY INFORMATION AND IT SHALL NOT BE USED OR REPRODUCED OR ITS CONTENT DISCLOSED, IN WHOLE OR PART, WITHOUT THE PRIOR WRITTEN CONSENT OF ADVANCED POLY-PACKAGING INC.		REV.

## 5.16 Assembly => TA-T10009

### PTFE Guide Sub-Assembly

See Dwg# TA-T10009

1	TP-T1MB00034	Bracket Plate Finger (PTFE)
2	TP-T1MB00040	Rod, PTFE (2/M)
3	TP-108156	Extension Spring, PTFE Roll
4	TP-300500	PTFE Sheet (T-1000)

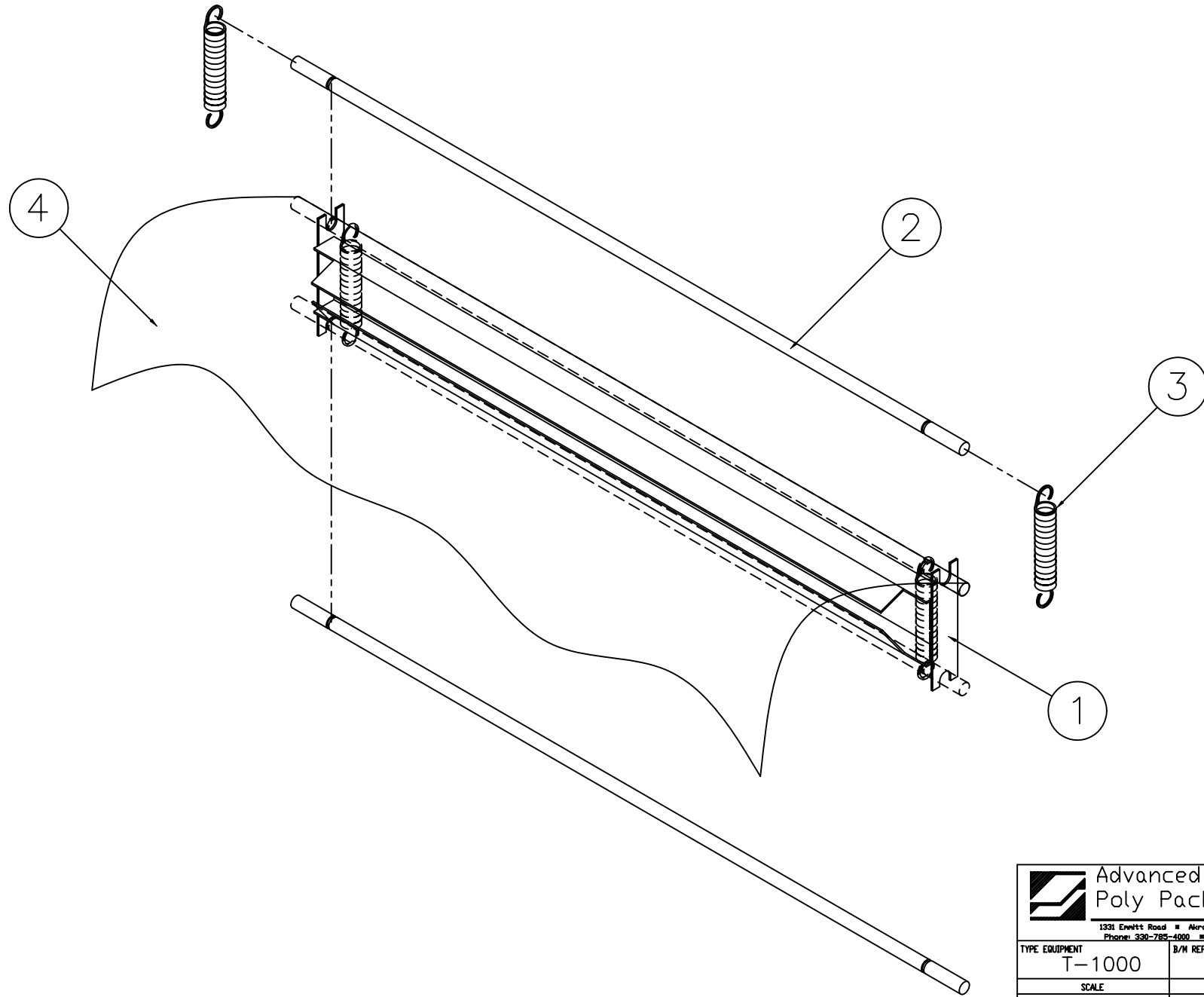

 <b>Advanced Poly Packaging Inc.</b> <small>1331 Ewhitt Road # Akron # Ohio 44306          Phone: 330-785-4000 # Fax: 330-785-4010</small>		
TYPE EQUIPMENT T-1000	B/W REF. NDL	PART NDL
SCALE N.T.S	DRAWN BY NAME MELODY DATE 7/18/00	APPROVED NAME DATE
TITLE TEFLON GUIDE SUB-ASSEMBLY		DRAWING NDL TA-T10009
		REV.

NOTICE: THIS DOCUMENT CONTAINS PROPRIETARY INFORMATION AND IT SHALL NOT BE USED OR REPRODUCED OR ITS CONTENT DISCLOSED, IN WHOLE OR PART, WITHOUT THE PRIOR WRITTEN CONSENT OF ADVANCED POLY-PACKAGING INC.





## 5.17 Assembly => TA-T10012

### Grooved Roller Mounting Sub-Assembly

See Dwg# TA-T10012

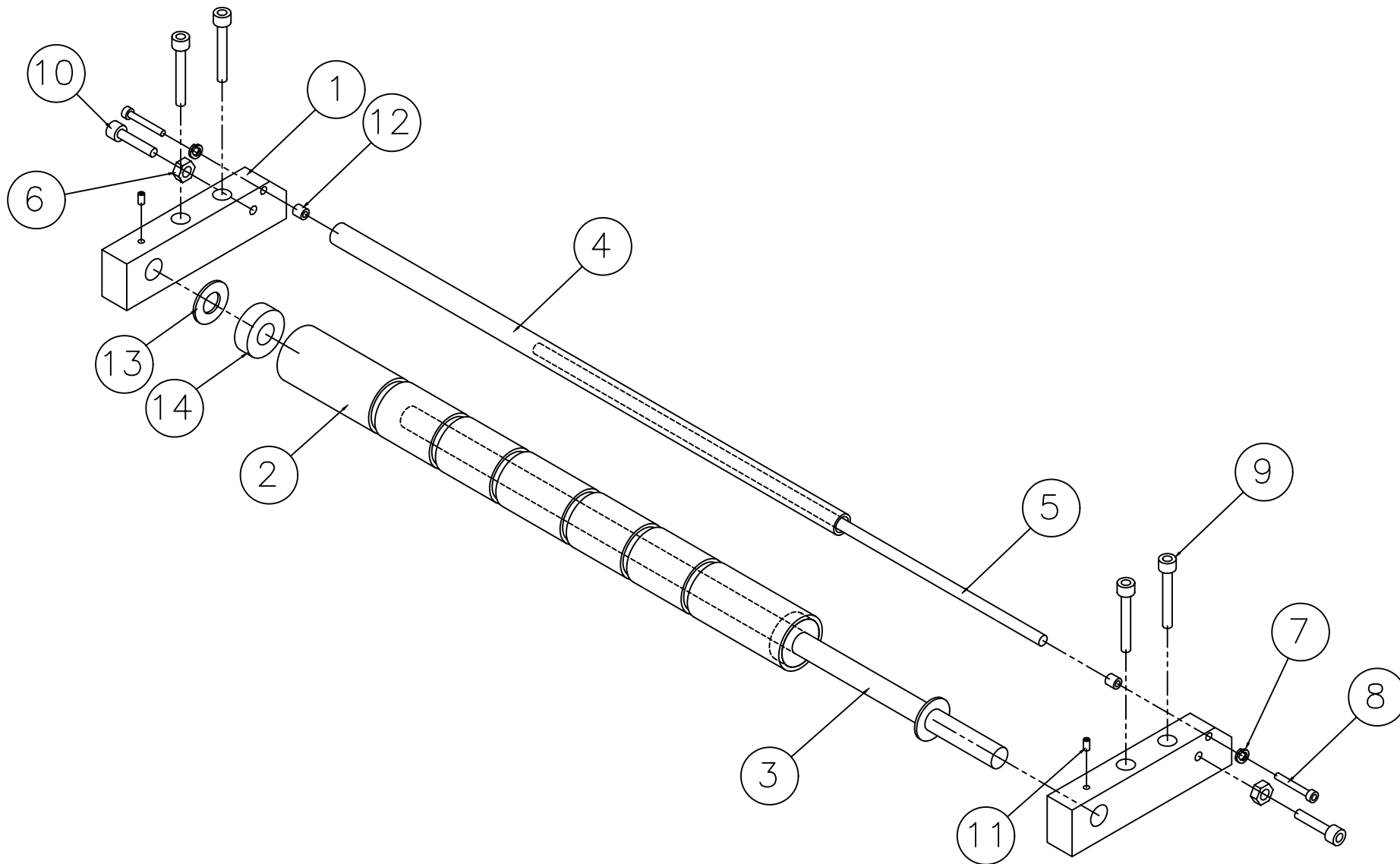
1	TP-T1MB00004	Grooved Metal Roller Mount
2	TP-T1MB00012	Grooved Lower Roller (Steel)
3	TP-T1MB00013	Grooved Lower Roller Shaft
4	TP-T1MB00155	S Frame Film Web Tension Roll
5	TP-T1MB00156	S Frame Film Web Tension Roll
6	TP-101143	Locknut, Hex Nylon Insert
7	TP-102153	Washer, #8 Med Split Lock Z
8	TP-103118	Screw, SHCS 8-32 x 1
9	TP-103141	Screw, SHCS 1/4-20 x 1-1/4
10	TP-103249	Screw, SHCS Nylon 1/4-20
11	TP-103260	Set-screw, 8-32 x 1/4
12	TP-107163	Bushing, Sleeve 1/4 ID
13	TP-107227	Bushing, Thrust Nylon 1/2ID
14	TP-504107	Bearing, Nice 1616



 <b>Advanced Poly Packaging Inc.</b> <small>1331 Ewhitt Road ■ Akron ■ Ohio 44306          Phone: 330-785-4000 ■ Fax: 330-785-4010</small>		
TYPE EQUIPMENT T-1000	B/W REF. NDL	PART NDL
SCALE N.T.S	DRAWN BY NAME MELODY DATE 7/25/00	APPROVED NAME DATE
TITLE GROOVED ROLLER MOUNTING SUB-ASSEMBLY		DRAWING NDL TA-T10012 REV.

NOTICE: THIS DOCUMENT CONTAINS PROPRIETARY INFORMATION AND IT SHALL NOT BE USED OR REPRODUCED OR ITS CONTENT DISCLOSED, IN WHOLE OR PART, WITHOUT THE PRIOR WRITTEN CONSENT OF ADVANCED POLY-PACKAGING INC.

## 5.18 Assembly => TA-T10017

### Bag Finger Grounding Assembly

See Dwg# TA-T10017

1	TA-T100124-1	High Voltage Sensor
2	TP-T1MB00028	Grooved Metal Roller Finger
3	TP-T1ME00325	Grounding Sensor Wire Assembly
4	TP-101102	Nut, 6-32 Hex Mach Screw Pltd
5	TP-102102	Lockwasher, #6 Int Tooth Pltd
6	TP-102132	Washer, #6 SAE Flat Zinc
7	TP-103207	Screw, BHCS 6-32 x 3/8 Blk

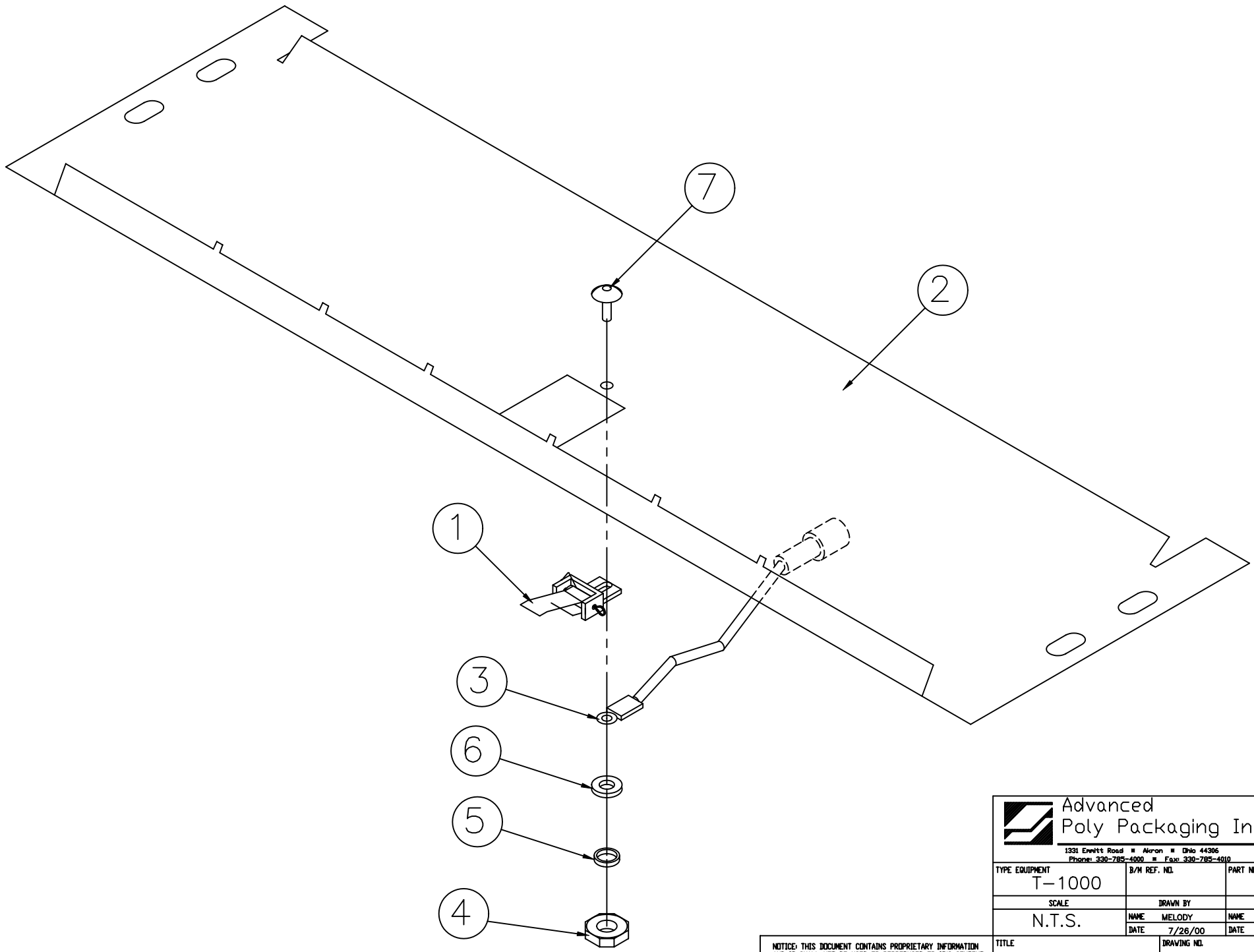

 <b>Advanced Poly Packaging Inc.</b> <small>1331 Erwin's Road # Akron # Ohio 44306          Phone: 330-785-4000 # Fax: 330-785-4010</small>		
TYPE EQUIPMENT T-1000	B/M REF. NDL	PART NDL
SCALE N.T.S.	DRAWN BY NAME MELODY DATE 7/26/00	APPROVED NAME DATE
TITLE BAG FINGER GROUNDING ASSEMBLY		DRAWING NDL TA-T10017
		REV.

NOTICE: THIS DOCUMENT CONTAINS PROPRIETARY INFORMATION AND IT SHALL NOT BE USED OR REPRODUCED OR ITS CONTENT DISCLOSED, IN WHOLE OR PART, WITHOUT THE PRIOR WRITTEN CONSENT OF ADVANCED POLY-PACKAGING INC.

## 5.19 Assembly => TA-T10199

### Stand Assembly, T-1000

See Dwg# TA-T10199

1	TA-T10200	Base Assembly
2	TA-T10210	Upper Column Assembly
3	TA-T10220	Dancer Assembly

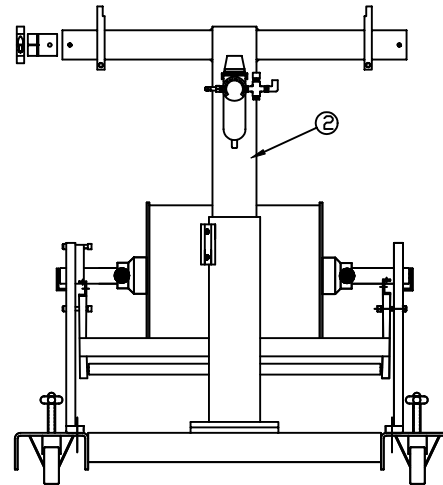
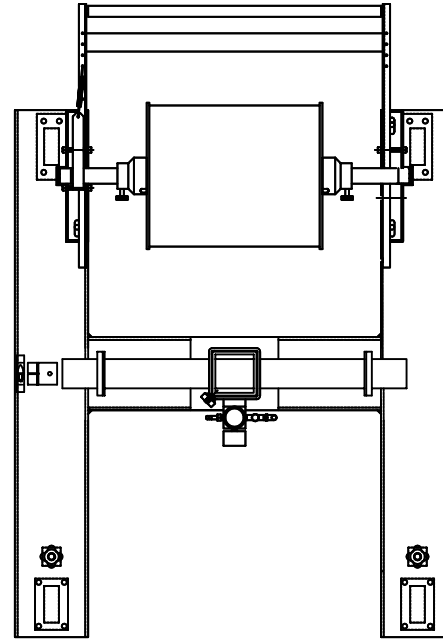
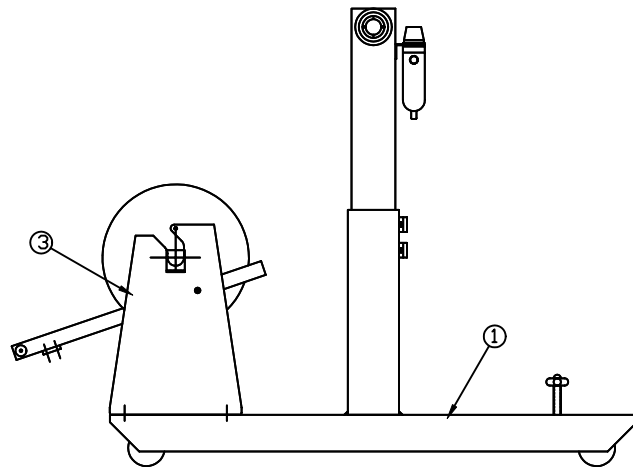

 <b>Advanced Poly Packaging Inc.</b> <small>1200 Emory Road • Alphen • Ohio 44095          Phone 330-780-2888 • Fax 330-780-2889</small>			
TYP. EQUIPMENT	DRAWING NO.	PART NO.	
T-1000			
SCALE	DRAWN BY	APPROVED	
N.T.S.	MMB/MAC		
	DATE	DATE	DATE
	7/31/00		
TITLE		DRAWING NO.	REV.
STAND ASSEMBLY		TA-T10199	

NOTICE: THIS DOCUMENT CONTAINS PROPRIETARY INFORMATION AND IT SHALL NOT BE USED OR REPRODUCED OR ITS CONTENTS DISCLOSED, IN WHOLE OR PART, WITHOUT THE WRITTEN CONSENT OF ADVANCED POLY-PACKAGING INC.

## 5.20 Assembly => TA-T10200

### Base Assembly

See Dwg# TA-T10200

1	TP-T1MA00051	Lower Base Weldment
2	TP-T1MA00051-1	Lower Column
3	TP-T1MA00102	Floor Leveler, Base Assembly
4	TP-102156	Washer, 5/16 Med Split Lock
5	TP-102157	Washer, 3/8 Med Split Lock
6	TP-103161	Screw, SHCS 5/16-18 x 5/8
7	TP-103165	Screw, SHCS 3/8-16 x 7/8
8	TP-110756	Swivel Caster
9	TP-110763	Rigid Caster

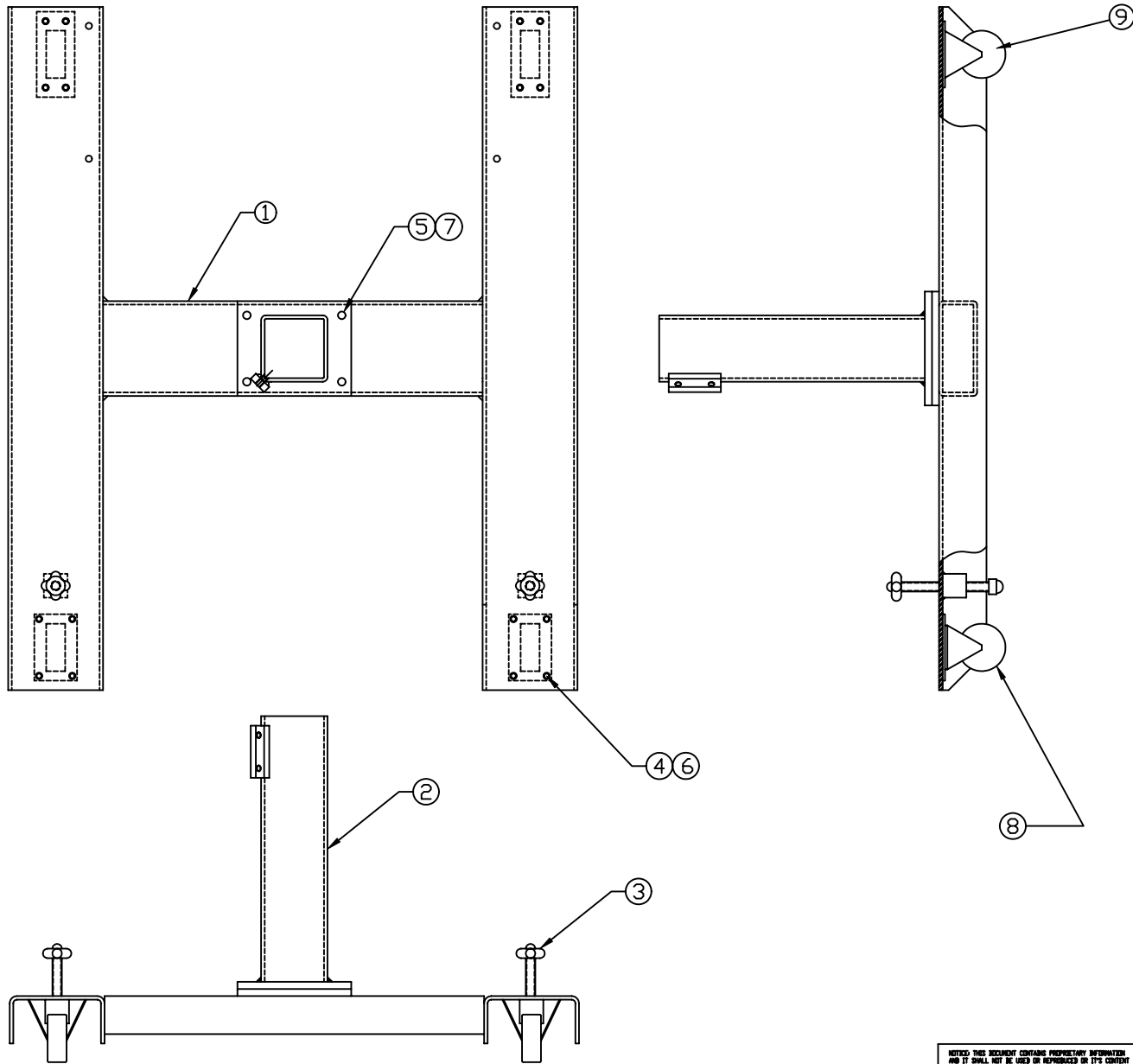

 <b>Advanced Poly Packaging Inc.</b> <small>252 Emery Road • Akron • Ohio 44306          Phone 330-792-2600 • Fax 330-792-2601</small>			
TYP. EQUIPMT	DWG. NO.	PART NO.	
T-1000			
SCALE	DRAWN BY	APPROVED	
N.T.S.	DATE	DATE	DATE
	7/31/00		
TITLE		DRAWING NO.	
BASE ASSEMBLY		TA-T10200	
		REV.	

NOTICE: THIS DOCUMENT CONTAINS PROPRIETARY INFORMATION AND IT SHALL NOT BE USED OR REPRODUCED OR ITS CONTENTS DISCLOSED, IN WHOLE OR IN PART, WITHOUT THE WRITTEN CONSENT OF ADVANCED POLY-PACKAGING INC.





## 5.21 Assembly => TA-T10210

### Upper Column Assembly

See Dwg# TA-T10210

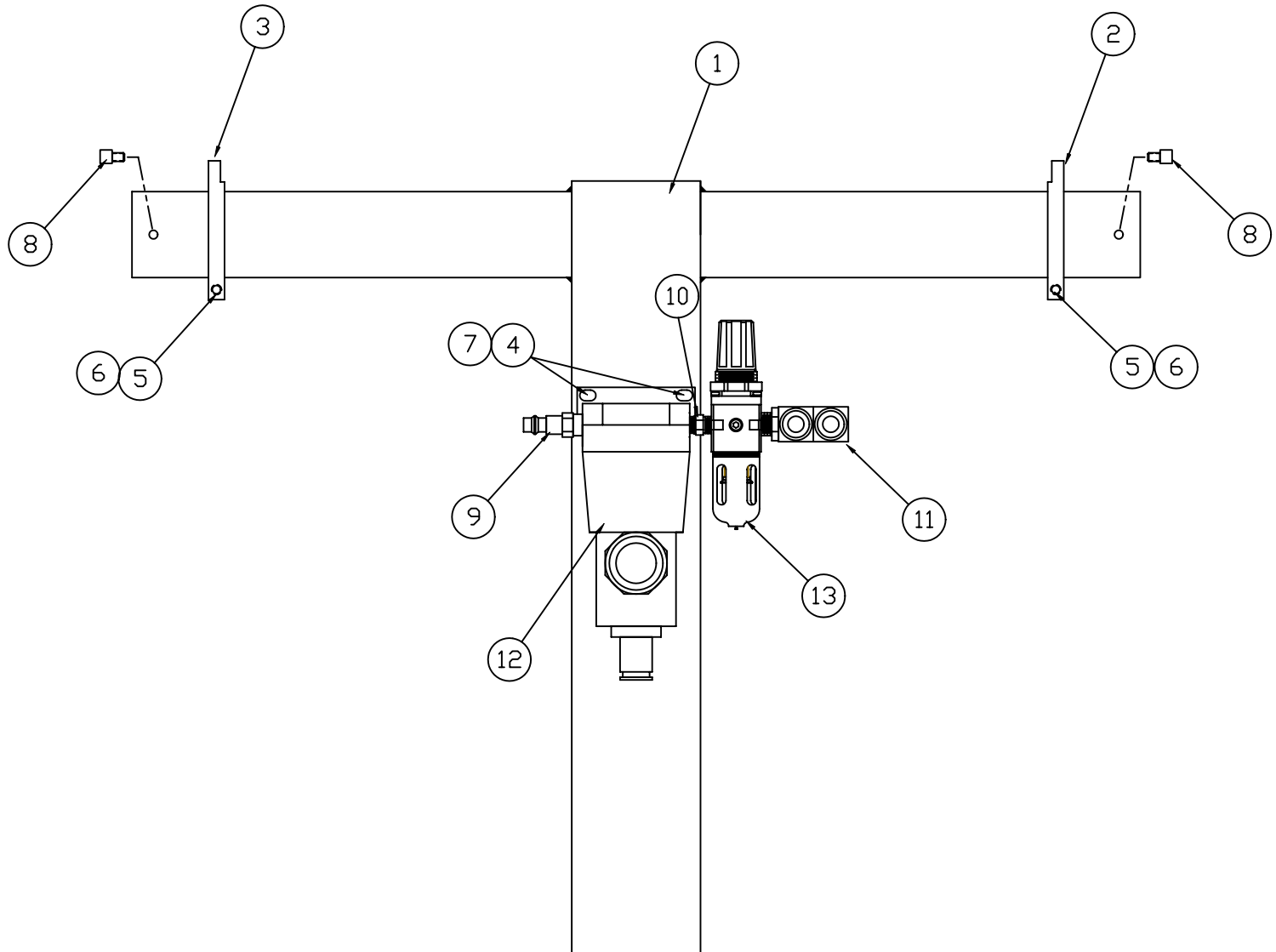
1	TP-T1MA00087	Cross Pipe Weldment
2	TP-T1MC00019-1	Base Clamp Block (Left)
3	TP-T1MC00019-2	Base Clamp Block (right)
4	TP-102154	Washer, #10 Med Split Lock
5	TP-102156	Washer, 5/16 Med Split Lock
6	TP-103012	Screw, SHCS 5/16-18 x 2-1/2
7	TP-103129	Screw, SHCS 10-32 x 1/2 BLK
8	TP-103137	Screw, SHCS 1/4-20 x 1/2
9	TP-401222	Nipple, 1/4 NPT Quick Conn
10	TP-401224	Nipple, 1/4" Hex Nipple
11	TP-401267	Double Universal Elbow 1/4
12	TP-406005	Air Dryer, AD-10
13	TP-406246	Regulator / Filter / Bracket



**Advanced Poly Packaging Inc.**  
1331 Emmit Road • Akron • Ohio 44306  
 Phone: 330-785-4000 • Fax: 330-785-4010

TYPE EQUIPMENT T-1000	B/W REF. NDL	PART NDL
SCALE N.T.S	DRAWN BY NAME MELODY DATE 8/1/00	APPROVED NAME DATE
TITLE UPPER COLUMN ASSEMBLY		DRAWING NDL TA-T10210

NOTICE: THIS DOCUMENT CONTAINS PROPRIETARY INFORMATION  
 AND IT SHALL NOT BE USED OR REPRODUCED OR ITS CONTENT  
 DISCLOSED, IN WHOLE OR PART, WITHOUT THE PRIOR WRITTEN  
 CONSENT OF ADVANCED POLY-PACKAGING INC.

## 5.22 Assembly => TA-T10220

### Dancer Assembly

See Dwg# TA-T10220

1	TA-T10010	Film Tension Hub Sub-Assembly
2	TA-T10011	Dancer Guide Sub-Assembly
3	TP-T1MA00069-1	Dancer Side Frame Plate (Left)
4	TP-T1MA00069-2	Dancer Side Frame Plate (Right)
5	TP-T1MA00073	Shaft, Bag Roll (T-1000)
6	TP-T1MA00115	Brake Tension Strap (Dance)
7	TP-101141	Locknut, Hex Nylon Insert
8	TP-102143	Washer, SAE Flat Zinc 5/16
9	TP-102156	Washer, 5/16 Med Split Lock
10	TP-103144	Screw, SHCS 5/16-18 x 3/4
11	TP-103237	Screw, BHCS 5/16-18 x 1
12	TP-103307	Screw, Sock Shldr 1/4x1-1/2
13	TP-504132	Cam Follower

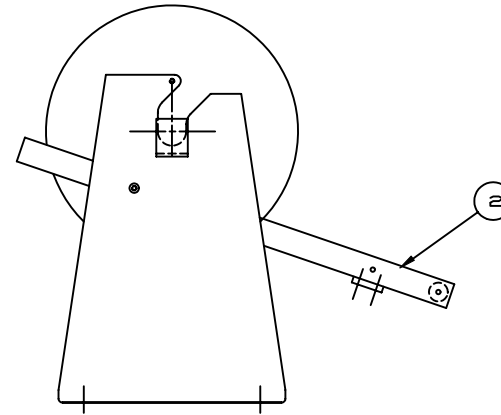
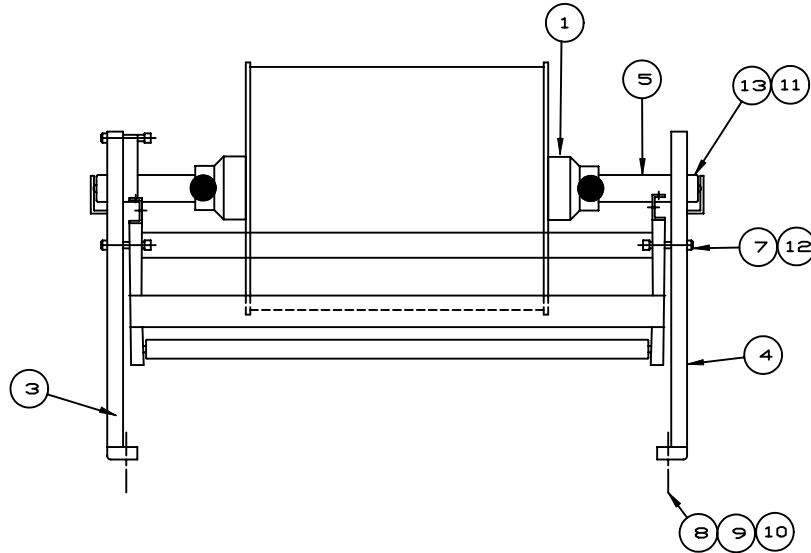
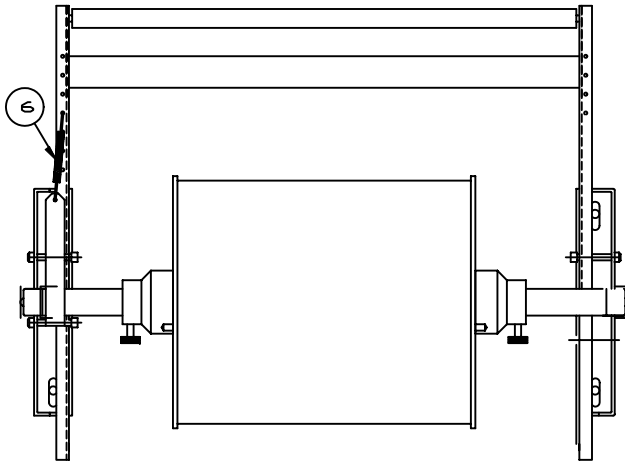

QUANTITY	REV	DATE	BY	DESCRIPTION
—				
MATERIAL				
—				
FINISH				
—				
TOLERANCES UNLESS OTHERWISE NOTED: +/- .015 ON FRACTIONAL DIMENSIONS +/- .010 ON TWO PLACE DECIMAL DIMENSIONS +/- .003 ON THREE PLACE DECIMAL DIMENSIONS 125 ✓ ON MACHINED SURFACES ALL DIMENSIONS ARE IN INCHES PART MUST BE FREE OF BURRS AND SHARP EDGES				1331 Ewhitt Road ■ Akron ■ Ohio 44306 Phone 330-785-4000 ■ Fax 330-785-4010
TYPE EQUIPMENT		B/M REF. NO.		PART NO.
T-1000				—
SCALE		DRAWN BY		APPROVED
1:4		NAME MELODY		NAME
		DATE 10/11/01		DATE
NOTICE: THIS DOCUMENT CONTAINS PROPRIETARY INFORMATION AND IT SHALL NOT BE USED OR REPRODUCED OR ITS CONTENT DISCLOSED, IN WHOLE OR PART, WITHOUT THE PRIOR WRITTEN CONSENT OF ADVANCED POLY-PACKAGING INC.				TITLE DANCER ASSEMBLY
DRAWING NO.				REV.
TA-T10220				—

## 5.23 Assembly => TA-T10011

### Dancer Guide Sub-Assembly

See Dwg# TA-T10011

1	TP-T1MA00072	Dancer Tension Bar
2	TP-T1MA00081	Dancer Tension Bar Cross B
3	TP-T1MA00089	Dancer Roller 1.101.A21.00
4	TP-T1MA00090	Dancer Guide Roller Shaft
5	TP-T1MA00186	Tension Adjuster & Spacer
6	TP-101144	Nut, Hex Mach Screw
7	TP-102153	Washer, #8 Med Split Lock Z
8	TP-102154	Washer, #10 Med Split Lock
9	TP-102155	Washer, 1/4 Med Split Lock
10	TP-103116	Screw, SHCS 8-32 x 1/2
11	TP-103170	Screw, SHCS 10-32 x 5/8
12	TP-109212	Knob, Torque 1/4-20 x 1
13	TP-504101	Roller Bearing, Nylon Intel

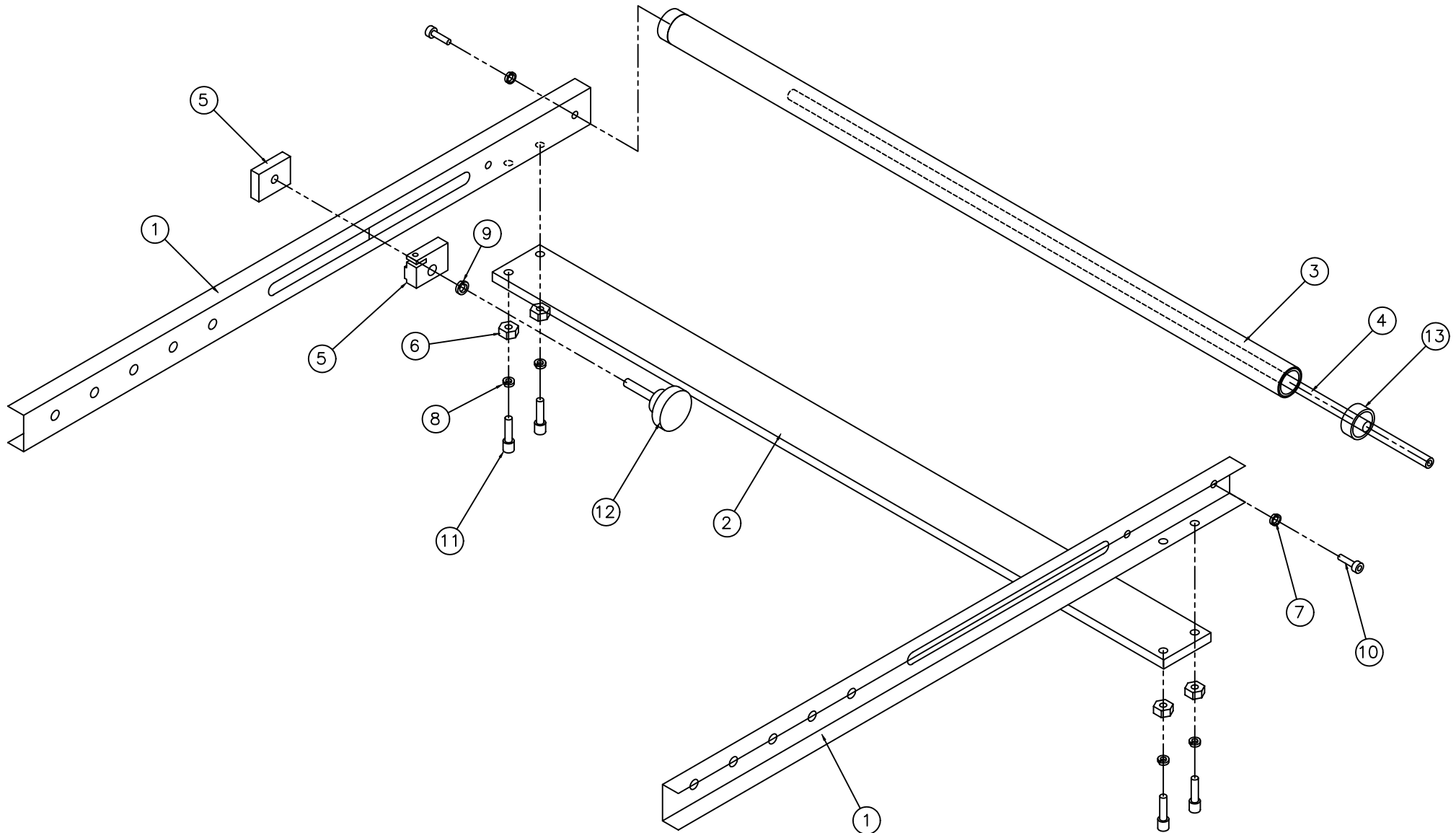

**Advanced Poly Packaging Inc.**  
 1331 Erwin's Road # Akron # Ohio 44306  
 Phone: 330-785-4000 # Fax: 330-785-4010

TYPE EQUIPMENT T-1000	B/M REF. NDL	PART NDL
SCALE N.T.S.	DRAWN BY MELODY	APPROVED NAME
	DATE 7/18/00	DATE
DRAWING NDL DANCER GUIDE SUB-ASSEMBLY		REV. A

REV	DATE	BY	DESCRIPTION
A	10/26/00	MELODY	ADDED THE TENSION ADJUSTER AND SLOT ON THE DANCER BAR

NOTICE: THIS DOCUMENT CONTAINS PROPRIETARY INFORMATION AND IT SHALL NOT BE USED OR REPRODUCED OR ITS CONTENT DISCLOSED, IN WHOLE OR PART, WITHOUT THE PRIOR WRITTEN CONSENT OF ADVANCED POLY-PACKAGING INC.

## 5.24 Assembly => TA-T10240

### Touch Screen Control Case Assembly

See Dwg# TA-T10240

1	TP-T1MA00088	Base Clamp Pipe Insert
2	TP-T1MD00039	Control Case Touch Screen
3	TP-T1MD00039-1	Control Case Touch Screen Back Plate
4	TP-T1MD00039-3	Touch Screen Front Plate, Plain
5	TP-T1MD00094	Touch Screen Tube Short
6	TP-T1MD00109	Mounting Bar, Touch Screen
7	TP-T10MA0041	Touch Screen Bracket
8	TP-102134	Washer, #10 SAE Flat Zinc
9	TP-102154	Washer, #10 Med Split Lock
10	TP-103129	Screw, SHCS 10-32 x 1/2 BLK
11	TP-103207	Screw, BHCS 6-32 x 3/8 Blk
12	TP-103211	Screw, BHCS 8-32 x 3/8 BLK
13	TP-103256	Screw, SHCS M3-12
14	TP-111104	Clamp, Collar 2 pc Split 1
15	TP-111118	Bracket, Swivel Ball Socket
16	TP-111215	Joining Tee 3/4" Pipe 1" T
17	TP-220364	Touch Screen
18	TP-220365	Cable, Communication, Touch Screen

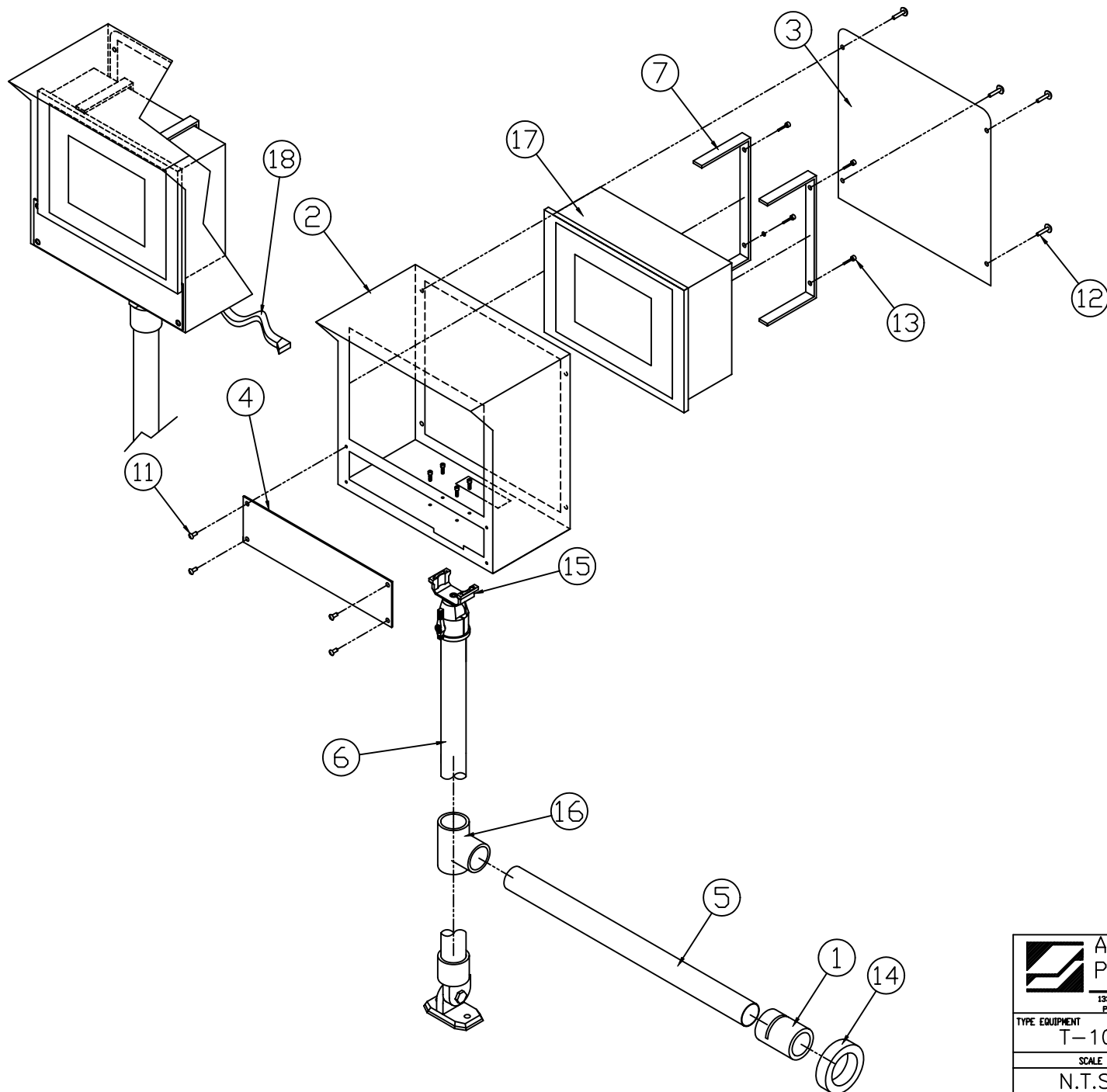

NOTICE: THIS DOCUMENT CONTAINS PROPRIETARY INFORMATION AND IT SHALL NOT BE USED OR REPRODUCED OR ITS CONTENT DISCLOSED, IN WHOLE OR PART, WITHOUT THE PRIOR WRITTEN CONSENT OF ADVANCED POLY-PACKAGING INC.

 <b>Advanced Poly Packaging Inc.</b> <small>1331 Enright Road # Akron # Ohio 44306          Phone: 330-785-4000 # Fax: 330-785-4010</small>			
TYPE EQUIPMENT T-1000	B/M REF. NDL	PART NDL	
SCALE N.T.S	NAME MELODY	DATE 8/1/00	APPROVED NAME DATE
TITLE IOP ASSEMBLY		DRAWING NDL TA-T10240	REV.



## 5.25 SP-10 Spare Parts Kit (Level 1) (P/N T-SP-10)

APPI Part Number	Quantity	Description
TP-T1MA00115	1	Brake Tension Strap
TP-T1MC00124-1	1	High Voltage Sensor
TP-180155	2	Compression Spring, Pressure bar
TP111010	4	Spring Closure Collars (Web Guides)
TP-207206	3	Fuse, (2.5 Amp)
TP-207225	3	Fuse, Fast Act (1 Amp)
TP-207226	6	Fuse, (3.15 Amp)
TP-207227	3	Fuse, (5 Amp)
TP-207228	3	Fuse, (10 Amp)
TP-221416	2	Thermocouple Wire
TP-217116	1	Cartridge Heater
TP-300500	2	PTFE Sheets
TP-306002	1	Anti-Jam Seal Bar Rubber
TP-404266	10'	Poly Tubing, 1/4" Blue
TP-404267	5'	Poly Tubing, 3/8" Blue
TP-406181	2	Filters (Micron Blower)
TP-503102	1	Belt, Brake
TP-503182	1	Belt, Clutch

## 5.26 SP-20 Spare Parts Kit (Level 2) (P/N T-SP-20)

APPI P/N	Qty	Description	APPI P/N	Qty	Description
TP-T1MA00115	2	Brake Tension Strap	TP-300500	2	PTFE Sheet
TP-T1MN00041	1	Main Seal Cylinder	TP-306002	2	Anti-Jam Seal Rubber
TP-T1MC00055	1	Brake Bushing	TP-401254	2	Tee Fitting 1/4 Poly
TP-T1MC00124-1	1	High Voltage Sensor (Top)	TP-401255	1	Elbow 3/8
TP-T1ME00301	1	High Voltage Board Assy	TP-401257	5	Elbow 1/4
TP-T1ME00208	1	Brake Coil Cable Harness	TP-401258	3	Straight Fitting 1/4
TP-T1ME00209	1	Seal Bar Cable Harness	TP-401275	1	Elbow 3/8 x 1/8
HP-35027A1	2	Sponge Replacement	TP-401276	1	Straight Fitting 3/8
TP-108155	2	Compression Spring	TP-401277	4	Elbow 1/4 x 10/32
TP-111010	4	Collars, Spring Closure	TP-401291	2	Elbow 1/4 x 1/4
TP-200348	1	Interface Board	TP-402184	1	Flow Control
TP-202216	1	Capacitor 6000uF	TP-402255	1	Valve (3000 series)
TP-205108	1	Filter (Corcom Line)	TP-402256	1	Valve (5000 series)
TP-206146	1	25 Amp Triac	TP-403243	1	Web Brake Cylinder
TP-207206	3	Fuse, (2.5 amp)	TP-403244	1	Cylinder (Main Seal)
TP-207216	1	Fuse Holder	TP-403245	1	Cylinder (Heater Bar)
TP-207225	3	Fuse Fast (1 AMP)	TP-404262	2	Bronze Muffler
TP-207226	2	Fuse (3.15 AMP)	TP-404266	10'	Tubing, 1/4" blue
TP-207227	3	Fuse (5 AMP)	TP-404267	5'	Tubing, 3/8" Blue
TP-207228	3	Fuse, (10 AMP)	TP-405268	1	Air Knife
TP-207344	3	Fuse, (12 AMP)	TP-406181	2	Filter, Micron Blower
TP-211391	1	Triad Dual Primary Trans	TP-501127	1	Motor
TP-212350	1	Terminal	TP-501130	1	Capacitor
TP-215200	2	Magnetic Switch	TP-502101	1	Clutch

APPI P/N	Qty	Description	APPI P/N	Qty	Description
TP-217116	1	Cartridge Heater	TP-503102	2	Clutch/Brake Bearing
TP-220367	1	PLC Controller	TP-503182	2	Belt, Brake
TP-220368	1	Touch Screen	TP-503108	2	Bearing
TP-221416	2	Thermocouple Wire	TP-504113	2	Roller Bearings
TP-504132	2	Cam Follower (CYR 1S)	TP-504114	2	Clutch/Brake Bearing

# Operation Guide

---

## Chapter 6, Preventive Maintenance & Scheduled Maintenance

PM Checklist

Schedule Maintenance (CHART)

## 6.1 Preventative Maintenance & Scheduled Maintenance

To extend the life of the T-1000, qualified maintenance personnel must perform all required maintenance tasks. Failure to perform scheduled and preventative maintenance may cause excessive wear to components and will void the warranty. For the purpose of this manual, preventative maintenance (PM) tasks are considered periodic tasks which should be performed on a daily, weekly or monthly basis.

Scheduled maintenance tasks are performed when the T-1000 Maintenance Chart Number changes to a higher number. Scheduled maintenance tasks (CHART items) are performed dependent upon the number of machine cycles and therefore are not considered "periodic" tasks.

### Legend for Preventative Maintenance Checklist

D	Daily
W	Weekly
M	Monthly

## 6.2 Preventative Maintenance Checklist

ITEM	DESCRIPTION	PERIOD
Filter / Air regulator	Drain water from filter	D
Air regulator	Adjust pressure to 80 PSI	D
Anti-jam device	Check operation, adjust as needed (Chapter 4.10)	D
Pressure bar (rubber)	Clean with alcohol	D
Perforation sensor	Clean sensor assembly with alcohol	W
Upper (rubber) roller	Inspect for nicks or cuts, clean with alcohol	W
Lower (alum.) roller	Clean with alcohol	W
Micron filter / Venturi	Inspect for contamination of filter, replace as needed Inspect for blockage / air restriction	M
Wiring / Connectors	Inspect for loose wiring / connectors, tighten as needed	M
Air lines / Valves / Cylinders	Inspect for loose air lines, listen for leaks, tighten or replace poly tubing as needed	M
Compartments / Covers	Remove all covers, clean and blow out compartments with compressed air to remove dust and dirt	M
Side-plates	Clean and wipe down with lightweight oil (based upon environmental - humidity conditions)	M
Drive belts	Inspect for wear / fraying, replace if needed	M
Drive belt (right panel)	Inspect for looseness, tighten as required	M
Touch Screen cabinet / arms	Tighten set screws	M
Height adjustments screws	Tighten bolts	M

**CAUTION:** *Unplug power cord and disconnect air line prior to removing guards, funnels or covers. Preventative Maintenance must be performed by qualified maintenance personnel.*

### 6.3 Scheduled Maintenance Chart

ITEM	DESCRIPTION	CHART									
		1	2	3	4	5	6	7	8	9	10
Drive belt (right panel)	Adjust/Inspect for wear replace when necessary	0	0	0	0	0	0	0	0	0	0
Drive belt (left panel)	Inspect for wear, replace when necessary	0	0	0	0	0	0	0	0	0	0
Heater element & wiring	Inspect for fraying, cuts, loose connections	0	0	0	0	0	0	0	0	0	0
Pressure bar assembly	Disassemble, clean, inspect springs for wear, breakage (frequency dependent on environment and product)	0		0		0		0		0	
Guide rollers	Inspect for free movement	0	0	0	0	0	0	0	0	0	0
Roller bearings	Inspect for free movement	0	0	0	0	0	0	0	0	0	0
Perf sensor & spring	Inspect for wear, replace when necessary		0		0		0		0		0
Upper rubber roll	Inspect for cuts, unevenness	0		0	0	0	0	0	0	0	0
Lower aluminum roller	Clean w/ alcohol, inspect for burs	0	0	0	0	0	0	0	0	0	0
Printed circuit boards	Blow off with clean, dry air, inspect for loose wires, connectors	0	0	0	0	0	0	0	0	0	0
Main Seal Cylinder	Listen for air leakage, replace or repair as required	0	0	0	0	0	0	0	0	0	0
Air (blower) filter	Inspect for contamination, replace as necessary	0	0	0	0	0	0	0	0	0	0
Air lines & connectors	Inspect for wear, cuts, leaking, replace as required	0	0	0	0	0	0	0	0	0	0
	INITIALS										

(Note: Each chart change represents 1MM cycles)



## 7.1 Trouble Shooting Guide

The items included in this section cover the common causes of trouble which an operator might encounter during the operation of the T-1000. When operating difficulties occur, the best procedure is to observe what is happening; then search out the causes; and effect the correction. Make only one adjustment at a time, checking the results of each adjustment. If an adjustment does not help or escalates the problems, return the settings back to the former position.

*CAUTION: These tests and repairs should be performed only by qualified mechanics or electricians and at their own risk.*

*NOTE: When trouble shooting a T-1000 functioning within a system (e.g.: with conveyors, scales, feeders, counters, etc.), always isolate the equipment and operate each machine individually.*

## 7.2 Troubleshooting Checklist

PROBLEM	POSSIBLE CAUSE	CORRECTIVE ACTION
Touch Screen does not display	<ol style="list-style-type: none"> <li>1. Power off</li> <li>2. Loose connection</li> <li>3. Fuse blown</li> <li>4. Contrast out of adjustment</li> </ol>	<ol style="list-style-type: none"> <li>1. Plug in power cord / turn on</li> <li>2. Tighten connections</li> <li>3. Replace fuse(s)</li> <li>4. Adjust screen contrast</li> </ol>
No main power light	<ol style="list-style-type: none"> <li>1. Blown fuse</li> <li>2. Bulb out</li> </ol>	<ol style="list-style-type: none"> <li>1. Replace fuse</li> <li>2. Replace bulb</li> </ol>
Pressure bar does not move when foot switch is operated	<ol style="list-style-type: none"> <li>1. Disconnected air line/foot switch</li> <li>2. Power off</li> </ol>	<ol style="list-style-type: none"> <li>1. Hookup air line</li> <li>2. Turn on power</li> </ol>
Pressure bar moves inward but does not reach the front plate (retracts immediately)	<ol style="list-style-type: none"> <li>1. Anti-jam improperly adjusted</li> <li>2. Misalignment of guide rods</li> <li>3. Insufficient air pressure</li> <li>4. Loose / broken ground wire on guide rods</li> </ol>	<ol style="list-style-type: none"> <li>1. Adjust anti-jam (section 4.10)</li> <li>2. Align guide rods (section 4.8)</li> <li>3. Increase air pressure</li> <li>4. Connect / tighten ground wires</li> </ol>
Pressure bar presses against front plate but does not seal bag	<ol style="list-style-type: none"> <li>1. Seal time too low</li> <li>2. Heat (temp.) too low</li> <li>3. Heater cartridge bad</li> <li>4. Insufficient air pressure</li> <li>5. Misalignment of guide rods</li> <li>6. PTFE folded over</li> <li>7. Heater bar not extending</li> <li>8. Seal cylinder bad</li> <li>9. Heater bar cylinder(s) bad</li> </ol>	<ol style="list-style-type: none"> <li>1. Increase in bag setup screen</li> <li>2. Increase in bag setup screen</li> <li>3. Replace heater cartridge</li> <li>4. Increase air pressure</li> <li>5. Align guide rods</li> <li>6. Turn PTFE</li> <li>7. Check heater bar cylinders / valve</li> <li>8. Replace cylinder / valve</li> <li>9. Replace cylinder / valve</li> </ol>



Bag sticks to PTFE or pressure (rubber) bar	<ol style="list-style-type: none"> <li>1. Seal temp. too high</li> <li>2. Seal time too high</li> <li>3. PTFE in poor condition</li> <li>4. Rubber is dirty / contaminated</li> </ol>	<ol style="list-style-type: none"> <li>1. Decrease temp in bag setup screen</li> <li>2. Decrease seal time in bag setup screen</li> <li>3. Turn / replace PTFE</li> <li>4. Clean / replace pressure bar rubber</li> </ol>
Bag does not tear off completely	<ol style="list-style-type: none"> <li>1. Bag slipping through rollers</li> <li>2. Compression pressure insufficient</li> <li>3. Drive roller not reversing</li> <li>4. Bag did not index properly</li> <li>5. Seal rubber dirty / worn</li> </ol>	<ol style="list-style-type: none"> <li>1. Clean upper and lower rollers with alcohol to remove slip and dirt build-up</li> <li>2. Adjust roller compression</li> <li>3. Check tear off cylinder</li> <li>4. Index another bag for test</li> <li>5. Clean/ replace rubber</li> </ol>
Two bags index from rollers	<ol style="list-style-type: none"> <li>1. Bag is folded over</li> <li>2. Perf sensor dirty / damaged</li> <li>3. Perf sensitivity out of adjustment</li> <li>4. Ungrounded outlet causing electrical noise</li> <li>5. Auxiliary equipment - noise</li> <li>6. Seal point value too high</li> </ol>	<ol style="list-style-type: none"> <li>1. Lower inner frame and straighten bag</li> <li>2. Clean / replace perf sensor</li> <li>3. Contact APPI for perf adj.</li> <li>4. Plug into "clean" power source</li> <li>5. Contact APPI for solution</li> <li>6. Set value lower</li> </ol>
Bag does not completely index	<ol style="list-style-type: none"> <li>1. Perf is sensing hole in bag (vent)</li> <li>2. Seal position setting too low</li> </ol>	<ol style="list-style-type: none"> <li>1. Reposition bag</li> <li>2. Increase seal position in bag setup screen</li> </ol>
Bag web indexing to floor level without stopping on bag	<ol style="list-style-type: none"> <li>1. Perf Sensor not sensing bag</li> <li>2. Dirty / damaged sensor</li> <li>3. Perf sensor out of adjustment</li> </ol>	<ol style="list-style-type: none"> <li>2. Clean / replace sensor 1 &amp; 3. Contact APPI for adjustment</li> </ol>
Bags web breaking prematurely in machine	<ol style="list-style-type: none"> <li>1. Improper web tension</li> <li>2. Web dragging foreign objects</li> <li>3. Bag roll side-plates bent inward</li> </ol>	<ol style="list-style-type: none"> <li>1. Adjust tension</li> <li>2. Remove obstructions</li> <li>3. Repair / remove side-plates</li> </ol>

### 7.3 Interface PCB Voltage Table by Terminal Number

The following chart is provided to assist in further trouble shooting the T-1000.

# Operation Guide

---

## Chapter 7

### Trouble Shooting

All voltage measurements are made with the machine in MANUAL MODE with all options which might impede the operation of the machine shut off.

All measurements are made with these settings unless specified otherwise. All inputs that are listed as current sinking can be grounded to force the circuit on.

*Note: Component saver timers should be turned to the highest setting prior to testing voltages to ensure accuracy of readings.*

*Caution: If this method of trouble shooting is used, care should be taken to insure all personnel and other equipment are clear of the machine since all safeties would be overridden.*

TERM.	MEASURE	VOLTAGE	DESCRIPTION
J1-1	J1-2	28 V. A.C.	Low voltage A.C. for power supplies
J1-2	J1-1	28 V. A.C.	Low voltage A.C. for power supplies
J1-3		0 V. D.C.	D.C. Ground
J1-4		0 V. D.C.	D.C. Ground
J1-5	J1-3,4	35 V. D.C.	Unregulated D.C. for Low Voltage Power Supplies. (If missing and 28V. A.C. is present, check F1 Power Supply fuse.)
J1-6	J1-3,4	24 V. D.C. Regulated	Regulated Power Supply for PLC & Touch Screen. (If missing and 35V. D.C. is present, first unplug PLC, then Touch Screen to see if external short is shutting it down.)
J1-7	J1-3,4	24 V. D.C. Regulated	Regulated Power Supply for valves and control circuits. (If missing, and 35V. D.C. is present, open jaw to disconnect valves and control circuits to see if external short is shutting it down.)
J2-1	J1-3,4	24 V. Square Wave (1Hz-5K Hz.)	D.C. square wave proportional to the temperature. Approximately 240 Hz. at room temperature, 75 degrees F., and 2060 Hz. at 400 degrees F. (Volt meters without a frequency scale will frequently average the 50% duty cycle on the D.C. Scale and display any frequency as 12V. D.C.) If no output, check open thermocouple indicator E13.
J2-2	J2-3	.01 to .09 V. D.C.	Positive J-thermocouple input (white wire) referenced through 10 ohms to ground. Approximately .015 V. D.C. at 75 degrees F and .085 V D.C. at 400 degrees F. If no voltage check for open thermocouple indicator E13.
J2-3	J2-2	-.01 to -.09 V. D.C.	Negative J-thermocouple input (red wire) direct to thermocouple IC. See above for voltages.
J2-4	J1-3,4	0 V. D.C.	Open thermocouple alarm input to PLC. 0 volts equals normal operation. 24 V. D.C. indicates open thermocouple.

J2-5		Not Used	Unused interface diode circuit anode (E12).
J2-6		Not Used	Unused interface diode circuit cathode (E12)
J2-7	J1-3,4	0 V. D.C. to 24V. D.C. max.	Bagger Run/Stop command to auxiliary equipment. E11 on indicates run. Voltage determined by auxiliary equipment voltage on Aux. Plug 3-J up to 24 V D.C.. Requires joining D.C. Grounds on Aux.3-C. Current sinking .1A;0 volts equals bagger run or not connected. Other positive voltage indicates bagger stop.
J2-8	J1-3,4	0 V. D.C. or 22.6 V. D.C.	Bagger Run/Stop output command from PLC Y-D to I.F. board. 0 volts equals run with E11 on 22.6 volts indicates stop.
J2-9	J1-3,4	0 V D.C. or 22.6 V D.C.	Foil Out input to X-C on PLC. Operates E10 when foil out. Connects to Aux.3-I on back of bagger. 0 volts D.C. indicates foil out. 22.6 volts indicates run condition. Requires common ground.
J2-10	J1-3,4	0 V D.C.	Foil Out inverted input to I.F. Board. Not Used
J2-11	J1-3,4	0 V. D.C. or 23.6 V D.C.	Optical Part Sense/ Count non-inverting input (current sink) to X-D of PLC. 0 volts indicates an input and lights E9. 23.6 volts indicates no input. Available on Optical Part Sense/Count Sensor Plugs 1&2 pin 3 under left and right covers of the machine.
J2-12	J1-3,4	0 V D.C. or 24 V D.C.	Optical Part Sense/Count inverting input (current source) to inverting input on I.F. Board. 0 volts indicates no input. 24 volts indicates a current sourcing input and lights E9. Available on Optical Part Sense/Count Sensor Plugs 1&2 under left and right covers of the machine.
J3-1	J1-3,4	0 V. D.C. or 23.6 V. D.C.	Optical Touch (Palm) Button 2 (left side) non-inverting input (current sink) to X-8 on PLC. 23.6 volts indicates no input. 0 volts indicates an input and lights E-8. Available on Palm Button Plug 2-3 under left side cover of machine.
J3-2	J1-3,4	0 V..D.C. or 24 V. D.C.	Optical Touch (Palm) Button 2 (left side) inverting input (current source) to inverting input on I.F. Board. 0 volts indicates no input from touch button. 24 volts indicates an input and lights E-8. Available on Palm Button Plug 2-2 under left side cover of machine.
J3-3	J1-3,4	0 V. D.C. or 23.6 V. D.C.	Optical Touch (Palm) Button 1 (right side) non-inverting input (current sink) to X-9 on PLC. 23.6 volts indicates no input. 0 volts indicates an input and lights E-7. Available on Palm Button Plug 1-3 under right side cover of machine.

J3-4	J1-3,4	0 V. D.C. or 24 V. D.C.	Optical Touch (Palm) Button 1 (right side) inverting input (current source) to inverting input on I.F. Board. 0 volts indicates an input from touch button. 24 volts indicates an input and lights E-7. Available on Palm Button Plug 1-2 under right side cover of machine.
J3-5	J1-3,4	0 V. D.C. or 24 V. D.C.	High Voltage arm signal when clutch is engaged. 0 volts when drive roller is not running. 24 volts D.C. current source when clutch is engaged power high voltage sensing circuit. Lights green E1 on I.F. Board and green E1 on High Voltage Sensing Board. To measure, open jaw and release the web, then close the jaw. Have the meter all set up and the probes on the terminals to be measured. Cycle the machine and watch the meter. The clutch will stay running for about 2 seconds before the machine shuts off the clutch to prevent running bags onto the floor.
J3-6	J1-3,4	0 V. D.C. or 23.8 V. D.C.	Clutch and High Voltage arm command from PLC. 23.8 volts when off. 0 volts D.C. current sink turns on circuit and green E1 on I.F. Board along with green E1 on the High Voltage Sensing Board. Circuit shuts off automatically if no bag is sensed within 2 seconds.
J3-7	J1-3,4	0 V. D.C. or 21.8 V. D.C.	Brake command from PLC. 21.8 volts D.C. when circuit is off. 0 volts D.C. when circuit is activated and red E2 is on. Brake shuts off when motor stops running.
J3-8	J1-3,4	0 V. D.C. or 21.8 V. D.C.	Motor run command from PLC. 21.8 volts indicates circuit is off. 0 volts current sink from the PLC turns on motor and green E3. Motor shuts off after 2 minutes of nonuse.
J3-9	J1-3,4	0 V. D.C. or 22.6 V. D.C.	Heat command from PLC. 21.8 volts indicates heat command is off. 0 volts D.C. current sink turns on the circuit and lights amber E4. Heat control is proportional band. E4 and amber indicator on Touch Screen stay on longest when heat is furthest from the set point and pulse the quickest when the heat is closest to the set point.
J3-10	J1-3,4	0 V. D.C. or 22.6 V. D.C.	Auxiliary A.C. Switch (triac) typically used to operate the P-100 hot-stamp imprinter. Low voltage command from PLC to I.F. Board. 22.6 volts indicates the circuit is off. 0 volts D.C. current sink along with clear E5 illuminated indicates the circuit is on. Since A.C. voltage is supplied externally to the circuit by jumpers in the Aux.3 Port plug, N5 neon light which is in parallel with the triac,

			is on when the triac is off if the circuit has voltage applied, even though the machine may be shut off. This is the only neon which lights when its circuit is off!
J4-1	J1-3,4	0 V. D.C. or 24 V. D.C.	24 volts D.C. to all the control circuits on the I.F. Board and all the valves. This is from J1-7 through the jaw open switch located on the outer frame below the clutch bracket. This circuit is broken (0 volts) when the jaw is open.
J4-2	J1-3,4	24 V. D.C. or 0 V. D.C.	J4-1 signal inverted to the PLC X-A input. This signal is normally 0 volts unless the jaw is open, when it is 24 volts signaling the PLC the jaw is open.
J4-3	J1-3,4	24 V. D.C. or 0 V. D.C.	Auxiliary output relay coil current sinking input from PLC Y-1. 24 volts D.C. indicates the relay is off. 0 volts D.C. indicates the relay is on.
J4-4			Not used normally closed contact of auxiliary output relay.
J4-5			Not used normally closed contact of auxiliary output relay.
J4-6	Aux. Machine Common	Voltage Supplied by Auxiliary Machine	Normally open contact @ 5A. resistive to auxiliary machine (filler). Closes either maintained or pulsed depending on Aux. Option selected on Auxiliary Options Menu to signal auxiliary machine to fill bag.
J4-7	Aux. Machine Common	Voltage Supplied by Auxiliary Machine	Normally open contact @ 5A. resistive to auxiliary machine (filler). Closes either maintained or pulsed depending on Aux. Option selected on Auxiliary Options Menu to signal auxiliary machine to fill bag.
J5-1A	J5-2 (3rd terminal)	120 V. A.C.	Line 1 input to I.F. Board. Connected to J5-1. Furnishes 120 volts a.c. to 4 triac circuits: clutch, brake, motor, heater. (Jumpered to line 2.)
J5-1	J5-2 (3rd terminal)	120 V. A.C.	Line 1 input to I.F. Board. Connected to J5-1A. (Jumpered to line 2.) Furnishes 120 volts a.c. to 4 triac circuits: clutch, brake, motor, heater.
J5-2	J5-1A,1 (1st & 2nd terminal)	120 V. A.C.	Neutral 1 for line 1 input on 120 volt machines. (Neutral 1 joined to Line 2 for 230 volt machines).
J5-3	J5-4,5 (5th & 6th terminal)	120 V. A.C.	Line 2 input to I.F. Board. Jumpered to Line 1 input on 120 volt machines. (Line 2 input joined to neutral 1 on 230 volt machines.)
J5-4	J5-1A, 1 (1st & 2nd terminal)	120 V. A.C. (230 V. A.C.)	Neutral 2 input joined to J5-5. Jumpered to neutral 1 on 120 volt A.C. machines. (Not jumpered on 230 volt machines.)
J5-5	J5-1A,1 (1st & 2nd terminals)	120 V. A.C. (230 V. A.C.)	Neutral 2 input joined to J5-4. Jumpered to

			neutral 1 on 120 volt A.C. (Not jumpered on 230 volt machines.)
J5-6	J5-8 (9th terminal)	90 to 100 V. D.C.	+90 to +100 volts D.C. clutch drive voltage. Lights N1 neon (two electrodes) and N7 neon (one electrode) when voltage is applied while machine is advancing bags. (Check F2 if no light and bags do not advance after seal cycle.) (Turn off machine power and unplug J5. Measure 1040 ohms on clutch terminals.)
J5-7	J5-4,5 (5th & 6th terminal)	120 V. A.C.	Switched 120 volt a.c. to High Voltage Sensing Board. Provides primary voltage to high voltage transformer.
J5-8	J5-6 (7th terminal)	90 to 100 V. D.C.	-90 to -100 volts D.C. Clutch drive voltage. Lights N1 neon (two electrodes) and N7 neon (one electrode) when voltage is applied while machine is advancing bags. (Check F2 if no light and bags do not advance after seal cycle.) (Turn off machine power and unplug J5. Measure 1040 ohms on clutch terminals.)
J5-9	J5-10 (11th terminal)	90 to 100 V. D.C.	+90 to +100 volts D.C. brake drive voltage. Lights N6 neon (one electrode) when voltage is applied while machine is stopped with motor running. (Check F3 if no light after pressing STOP and then MAN.) (Turn off machine power and unplug J5. Measure 1040 ohms on brake terminals.)
J5-10	J5-9 (10th terminal)	90 to 100 V. D.C.	-90 to -100 volts D.C. brake drive voltage. Lights N6 neon (one electrode) when voltage is applied while machine is stopped with motor running. (Check F3 if no light after pressing STOP and the START.) (Turn off machine power and unplug J5. Measure 1040 ohms on brake terminals.)
J5-11	Local Neutral J5-4,5 (5th & 6th terminal) if Jumpered In J3 Aux. Port or Other Accessory Common	A.C. Voltage Only (120 V. A.C. For P-100)	A.C. input to high side of accessory triac Q12. Voltage furnished by jumpers in J3 Aux. Port Plug or remote accessory. N5 neon is lit if line voltage is present and triac circuit is off. N5 is shunted by the triac and extinguishes when the triac turns on to energize hot stamp printer or other remote accessory. (See notes for J5-12.)
J5-12	Local Neutral J5-4,5 (5th & 6th terminal) if Jumpered In J3 Aux. Port or Other Accessory Common	A.C. Voltage Only (120 V. A.C. For P-100)	A.C. Output from fuse F6 and load side of accessory triac Q12. Energizing for .5 seconds when web stops if TT printer selected or for an adjustable dwell in the HS mode. Check fuse F6 if neon N5 stays on and accessory will not cycle at end of bagger cycle and either Printer TT or HS is selected in printer setup screen. (See notes for J5-11.)

J5-13	J5-4,5 (5th & 6th terminal)	120 V. A.C.	Heater voltage to heat element. Lights N4 neon when heater is powered. Proportional band control. Full on when far from set point while only quick pulses when near set point. Check fuse F5 if N4 does not light when amber E4 lights. Turn off machine and unplug J5 to check heat cartridge resistance if no heat and light comes on. Should be 17 ohms between J5-13 and J5-4,5 or at heater plug underneath frame.
J5-14	J5-4,5 (5th & 6th terminal)	120 V. A.C.	Drive motor voltage. Press STOP and then START to make sure motor is running. (Only runs for 2 minutes if no demand.) Lights neon N3 when green E3 is lit. If N3 not lit check fuse F4.
J5-15	J5-4,5 (5th & 6th terminal)	120 V. A.C.	Optional parallel contact with J5-13 for heater power.

## 7.4 Wiring Tab (Point to Point)

The following point to point listing is provided to further assist in trouble shooting the wiring of the T-1000.

### SEAL BAR IN (2 PIN MOLEX)

BLK	WHT/BLK/BL	PLC INPUT PIN 23
BLK	WHT/GRN	PLC INPUT PIN 14

### JAW OPEN (2 PIN MOLEX)

BLK	YEL	IF/BD-J4 PIN 1
BLK	ORG	IF/BD-J1 PIN 7

### JAM DETECT (2 PIN MOLEX)

BLK	PINK	PIN 19 PLC INPUT
BLK	WHT/GRN	PIN 13 PLC INPUT

### HEATER BAR (2 PIN MOLEX)

BLK	PURPLE	IF/BD-J5 PIN-14
BLK	WHITE	IF/BD-J5 PIN-6

### THERMOCOUPLE (2 PIN CONN.)

POS+	WHITE	IF/BD-J2 PIN-2
NEG-	RED	IF/BD-J2 PIN-3

### BRAKE (SCREW CONN)

WIR-1	PURPLE	IF/BD-J5 PIN-10
WIR-2	PURPLE	IF/BD-J5 PIN-11

### CLUTCH (SCREW CONN)

WIR-1	GRAY	IF/BD-J5 PIN-6
WIR-2	GRAY	IF/BD-J5 PIN-8



MOTOR (5 PIN MOLEX)

BLK	BLACK	IF/BD-J5 PIN-14
BL	BLACK	JUMPED TO PIN-1
BLK	WHITE	IF/BD-J5 PIN-2 MOTOR STARTER CAP. PIN-1
BL	BL	MOTOR STARTER CAP. PIN-3
GRN / YEL	GREEN	CHASSIS GROUND

SOLENOID AIR VALVES (2 PIN MOLEX)

SAV-1 (MAIN SEAL PRES.)

BLK	YEL	IF/BD-J4 PIN-1
BLK	WHT/BLK/RED	PLC OUTPUT-PIN-27

SAV-2 (HEATER SEAL BOARD)

BLK	YEL	IF/BD-J4 PIN-1
BLK	WHT/BLK/BRN	PLC OUTPUT-PIN-25

SAV-3 (LOAD SHELF)

BLK	YEL	IF/BD-J4 PIN-1
BLK	WHT/BRN	PLC OUTPUT-PIN-11

SAV-4 (BAG LIFT)

BLK	YEL	IF/BD-J4 PIN-1
BLK	WHT/BLK/GRN	PLC OUTPUT-PIN-9 AND IF/BD J2-PIN-8

SAV-5 (TRIM SEAL)

BLK	YEL	IF/BD-J4 PIN-1
BLK	WHT/BLK/VOL	PLC OUTPUT-PIN-23

SAV-6 (PERF BREAK)

BLK	YEL	IF/BD-J4 PIN-1
BLK	WHT/BLK/GRY	PLC OUTPUT-PIN-24

SAV-7 (FLAT SEAL)

BLK	YEL	IF/BD-J4 PIN-1
BLK	WHT/BLK/BL	PLC OUTPUT-PIN-26

SAV-8 (ACCUM. FUNNEL)

BLK1	YEL	IF/BD-J4 PIN-1
BLK2	WHT/BLK/YEL	PLC OUTPUT-PIN-8

SAV-9 (VENTURI BLOWER)

BLK	YEL	IF/BD-J4 PIN-1
BLK	WHT/BLK	PLC OUTPUT-PIN-12

SAV-10 (AIR PULSE)

BLK	YEL	IF/BD-J4 PIN-1
BLK	WHT/BL	PLC OUTPUT-PIN-13

TOUCH SCREEN (CABLE 4 CONT.)

PIN+	RED	IF/BD J1-PIN-6
PIN-	GRN	IF/BD J1-PIN-3,4

HIGH VOLTAGE BOARD

J-1 (6 PIN CONN)

PIN-1	BLUE	IF/BD-J5 PIN-7
PIN-2	BLK	T-2 PIN-10 XFMR
PIN-3	ORG	IF/BD-J3 PIN-5

PIN-4	NOT USED	NA
PIN-5	GRN	TO CORCOM GROUND AND T-2XFMR GROUND
PIN-6	WHT	IF/BD-J5 PIN-2

J-2 (3 PIN CONN)

PIN-1	NOT USED	NA
PIN-2	NOT USED	NA
PIN-3	RED	PLC INPUT-PIN-21

J-3 (2 PIN CONN)

PIN-1	NOT USED	NA
PIN-2	YEL	TO H.V. SENSOR

J-4 (4 PIN CONN)

PIN-1	BLK	T-2XFMR
PIN-2	NOT USED	NA
PIN-3	NOT USED	NA
PIN-4	BLK	T-2XFMR

PLC BOARD

OUTPUTS (34 PIN CONN)

PIN-1	NOT USED	NA
PIN-2	NOT USED	NA
PIN-3	NOT USED	NA
PIN-4	NOT USED	NA
PIN-5	NOT USED	NA
PIN-6	NOT USED	NA
PIN-7	WTH/ORG	IF/BD J3-PIN-10, AUX-3 PIN-E
PIN-8	WHT/BLK/YEL	SAV-8
PIN-9	WHT/BLK/GRN	SAV-4, IF/BD J-2-PIN-8
PIN-10	BRN	IF/BD J-3-PIN-7
PIN-11	WHT/BRN	SAV-3
PIN-12	WHT/BLK	SAV-9
PIN-13	WHT/BL	SAV-10
PIN-14	RED	IF/BD J-3-PIN-6
PIN-15	NOT USED	NA
PIN-16	NOT USED	NA
PIN-17	NOT USED	NA
PIN-18	NOT USED	NA
PIN-19	NOT USED	NA
PIN-20	NOT USED	NA
PIN-21	NOT USED	NA
PIN-22	NOT USED	NA
PIN-23	WHT/BLK/VOL	SAV-5
PIN-24	WHT/BLK/GRY	SAV-6
PIN-25	WHT/BLK/BRN	SAV-2
PIN-26	WHT/BLK/BL	SAV-7
PIN-27	WHT/BLK/RED	SAV-1
PIN-28	WHT/GRY	IF/BD J3-PIN-8
PIN-29	BLUE	IF/BD J4-PIN-3
PIN-30	PINK	IF/BD J3-PIN-9
PIN-31	NOT USED	NA
PIN-32	NOT USED	NA
PIN-33	NOT USED	NA
PIN-34	NOT USED	NA

INPUT (30 PIN CONN)

PIN-1	NOT USED	NA
PIN-2	NOT USED	NA

PIN-3	WHT/BLK/ORG	AUX-3 PIN-I
PIN-4	YEL	AUX-3 PIN-H
PIN-5	WHT/VIO	IF/BD J-2-PIN-11
PIN-6	WHT/BL	IF/BD J-2 PIN-9
PIN-7	NOT USED	NA
PIN-8	NOT USED	NA
PIN-9	NOT USED	NA
PIN-10	NOT USED	NA
PIN-11	WHT/GRN	SEE NOTE:1
PIN-12	WHT/GRN	IF/BD J1-PIN-3 OR 4
PIN-13	WHT/GRN	JAM DETECT PIN-2
PIN-14	WHT/GRN	SEAL BAR IN PIN-2
PIN-15	BRN	IF/BD J2-PIN-4
PIN-16	WHT/YEL	IF/BD J4-PIN-2
PIN-17	WHT/BLK/GRY	IF/BD J3-PIN-3
PIN-18	WHT/BLK/BRN	IF/BD J3-PIN-1
PIN-19	PINK	JAM DETECT PIN-1
PIN-20	WHT/GRY	AUX-2 PIN-A
PIN-21	RED	HV/BD J2-PIN-3
PIN-22	WHT/ORG	FOOT SWITCH PIN-2
PIN-23	WHT/BLK/BL	SEAL BAR IN PIN-1
PIN-24	NOT USED	NA
PIN-25	NOT USED	NA
PIN-26	WHT/RED	IF/BD J2-PIN-1
PIN-27	NOT USED	NA
PIN-28	NOT USED	NA
PIN-29	NOT USED	NA
PIN-30	NOT USED	NA

POWER SUPPLY (5 PIN CONN)

PIN-1	BRN	IF/BD J1-PIN-6
PIN-2	RED	IF/BD J1-PIN-3 OR 4
PIN-3	REMOVED	NA
PIN-4	YEL	IF/BD J1-PIN-3 OR 4
PIN-5	GRN	IF/BD J1-PIN-7

IF BOARD

J-1 (7 PIN CONN)

PIN-1	RED	T-1XFMR PIN-6
PIN-2	RED	T-1XFMR PIN-10
PIN-3	GRN	CORCOM GROUND, FELTER CAP (-)NEG.
PIN-4	NOT USED	NA
PIN-5	RED	FILTER CAP (+) POS.
PIN-6	BRN	PLC POWER SUPPLY PIN-1
PIN-7	GRN	PLC POWER SUPPLY PIN-5

J-2 (12 PIN CONN)

PIN-1	WHT/RED	PLC INPUT PIN-26
PIN-2	WHITE	THEROCOUPLE (+) POS. CONN
PIN-3	RED	THEROCOUPLE (-) NEG. CONN
PIN-4	BRN	PLC INPUT PIN-15
PIN-5	NOT USED	NA
PIN-6	NOT USED	NA
PIN-7	WHT/BLK/RED	AUX-3 PIN-J
PIN-8	WHT/BLK/GRN	PLC OUTPUT PIN-9
PIN-9	WHT/BL	PLC INPUT PIN-6
PIN-10	NOT USED	NA

PIN-11	WHT/VIO	PLC INPUT PIN-5, OPT. PART SENSE PIN-3
PIN-12	VIO	OPTICAL PART SENSE PIN-2

J-3 (10 PIN CONN)

PIN-1	WHT/BLK/BRN	PLC INPUT PIN-18, TOUCH BUTTON-2 PIN-3
PIN-2	TAN	OPT. TOUCH BUTTON-2 PIN-2
PIN-3	WHT/BLK/GRY	PLC INPUT PIN-17, TOUCH BUTTON-1 PIN-3
PIN-4	GRY	OPT. TOUCH BUTTON-1 PIN-2
PIN-5	ORG	HV/BD J1-PIN-3
PIN-6	RED	PLC OUTPUT PIN-14
PIN-7	BRN	PLC OUTPUT PIN-10
PIN-8	WHT/GRY	PLC OUTPUT PIN-28
PIN-9	PINK	PLC OUTPUT PIN-30
PIN-10	WHT/ORG	PLC OUTPUT PIN-7, AUX-3 PIN-E

J-4 (4 PIN CONN)

PIN-1	YEL	JAW OPEN SW. PIN-1
PIN-2	WHT/YEL	PLC INPUT PIN-16
PIN-3	BLUE	PLC OUTPUT PIN-29
PIN-4	NOT USED	NA
PIN-5	NOT USED	NA
PIN-6	BLUE	AUX-2 PIN-E, AUX-1 PIN-E
PIN-7	WHT/BL	AUX-2 PIN-C, AUX-1 PIN-C

J-5 (14 PIN CONN)

PIN-1	BLACK	T-1XFMR PIN-1, CORCOM-LOAD (AC)
PIN-2	WHITE	T-1XFMR PIN-2, HV/BD J1-PIN-6
PIN-2	BLACK	T-1XFMR PIN-4, JUMPER TO IF/BD J5-PIN-1
PIN-4	WHITE	T-1XFMR PIN-5, JUMPER TO IF/BD J-5-PIN-2, MOTOR PIN-3
PIN-5	WHITE	HEATER PIN-2, CORCOM-LOAD (NEUTRAL)
PIN-6	GRAY	CLUTCH PIN-1
PIN-7	BLUE	HV/BD J1-PIN-1
PIN-8	GRAY	CLUTCH PIN-2
PIN-9	PURPLE	BRAKE PIN-1
PIN-10	PURPLE	BRAKE PIN-2
PIN-11	VIO	AUX-3 PIN-A
PIN-12	WHT/VIO	AUX-3 PIN-B
PIN-13	PURPLE	HEATER BAR PIN-1
PIN-14	BLACK	MOTOR PIN-1

AUX-3 (10 PIN CONN)

PIN-A	VIO	IF/BD J5 PIN-11, AUX-1 PIN-A
PIN-B	WHT/VIO	IF/BD J5 PIN-12, AUX-1 PIN-B
PIN-C	GREEN	IF/BD J1 PIN--3 OR 4, AUX-1 PIN-F, AUX-2 PIN-F
PIN-D	ORG	IF/BD J1 PIN-7
PIN-E	WHT/ORG	PLC OUTPUT PIN-7
PIN-F	BLACK	MAIN POWER SW. PIN-3
PIN-G	WHITE	MAIN POWER SW. PIN-4
PIN-H	YEL	PLC INPUT PIN-4
PIN-I	WHT/BLK/ORG	PLC INPUT PIN-3
PIN-H	WHT/BLK/RED	IF/BD J2-PIN-7

AUX-1 (6 PIN CONN)

PIN-A	VIO	AUX-3 PIN-A
PIN-B	WHT/VIO	AUX-3 PIN-B
PIN-C	WHT/BL	AUX-2 PIN-C
PIN-D	NOT USED	NA
PIN-E	BL	AUX-2 PIN-E

PIN-F	GREEN	AUX-3 PIN-C, AUX-2 PIN-F, IF/BD J1 PIN-3 OR 4
-------	-------	---

#### AUX-2 (6 PIN CONN)

PIN-A	WHT/GRY	PLC INPUT PIN-20
PIN-B	WHT/GRN	IF/BD J1-PIN-3 OR 4, FOOT SW. PIN-3
PIN-C	WHT/BU	IF/BD J4-PIN-7
PIN-D	NOT USED	NA
PIN-E	BLUE	IF/BD J4-PIN-6
PIN-F	GREEN	IF/BD J1 PIN-3 OR 4, AUX-1 PIN-F, AUX-3 PIN-C

#### FOOT SW. (3 PIN CONN)

PIN-1	GREEN	CORCOM STANDOFF
PIN-2	WHT/GRN	IF/BD J1-PIN-3 OR 4
PIN-3	WHT/ORG	PLC INPUT PIN-22

#### MAIN POWER SW.

PIN-1	NOT USED	NA
PIN-2	BLACK	FUSE PIN-2
PIN-3	BLACK	AUX-3 PIN-3, CORCOM LINE (AC), LINE OUT PLUG
PIN-4	WHITE	PWR CORD, CORCOM LINE (NEU), AUX-3 PIN-G, LINE OUT PLUG
PIN-5	NOT USED	NA
PIN-6	NOT USED	NA

#### MAIN FUSE

PIN-1	BLACK	PWR CORD
PIN-2	BLACK	MAIN POWER SW. PIN-2

#### LINE OUT PLUG

WIR-1	BLK WIRE	MAIN POWER SW. PIN-3
WIR-2	GREEN	CORCOM CASE GROUND
WIR-3	WHITE	MAINPOWER SW. PIN-4

#### OPTICAL TOUCH BUTTON (4 PIN MOLEX)

##### PLAM BUTTON-2 (LEFT SIDE)

PIN-1	ORG	IF/BD J1 PIN-7, PLAM BUTTOM-1 PIN-1
PIN-2	TAN	IF/BD J3 PIN-2
PIN-3	WHT/BLK/BRN	IF/BD J3 PIN-1
PIN-4	GREEN	IF/BD J1 PIN-3 OR 4, PLAM BUTTOM-1 PIN-4

##### PALM BUTTOM-1 (RIGHT SIDE)

PIN-1	ORG	IF/BD J1 PIN-7, PLAM BUTTOM-2 PIN-1
PIN-2	GREY	IF/BD J3 PIN-4
PIN-3	WHT/BLK/GRY	IF/BD J3 PIN-3
PIN-4	GREEN	IF/BD J1 PIN-3 OR 4, PLAM BUTTOM-2 PIN-4

#### OPTICAL PART SENSE/COUNT (4PIN MOLEX)

##### SENER-2 (LEFT SIDE)

PIN-1	ORG	IF/BD J1 PIN-7, SENSER-1 PIN-1
PIN-2	VIO	IF/BD J2 PIN-12, SENSER-1 PIN-2
PIN-3	WHT/VIO	IF/BD J2 PIN-11, SENSER-1 PIN-3
PIN-4	GREEN	IF/BD J1 PIN-3 OR 4, SENSER-1 PIN-4

##### SENER-1 (RIGHT SIDE)

PIN-1	ORG	IF/BD J1 PIN-7, SENSER-2 PIN-1
PIN-2	VIO	IF/BD J2 PIN-12, SENSER-2 PIN-2
PIN-3	WHT/VIO	IF/BD J2 PIN-11, SENSER-2 PIN-3
PIN-4	GREEN	IF/BD J1 PIN-3 OR 4, SENSER-2 PIN-4

## 7.5 Circuit Boards

PLC (Fig. 4-8)

### Output Indicators (LEDs) Y

0	Heater Circuit
1	Auxiliary Output
2	Motor Run / Standby (IF27)
3	Pressure Bar (SAV1)
4	Flat Seal Assembly (SAV7)
5	Heater Bar (SAV2)
6	Bag Tear Off (SAV6)
7	Trim Seal Blow Off (SAV5)
8	Clutch / Perf Sensor Circuit
9	Air Pulse (SAV10)
A	Blower (SAV9)
B	Load Shelf (SAV3)
C	Brake
D	Load Shelf (SAV4)
E	Accumulating Funnel (SAV8)
F	Printer Command

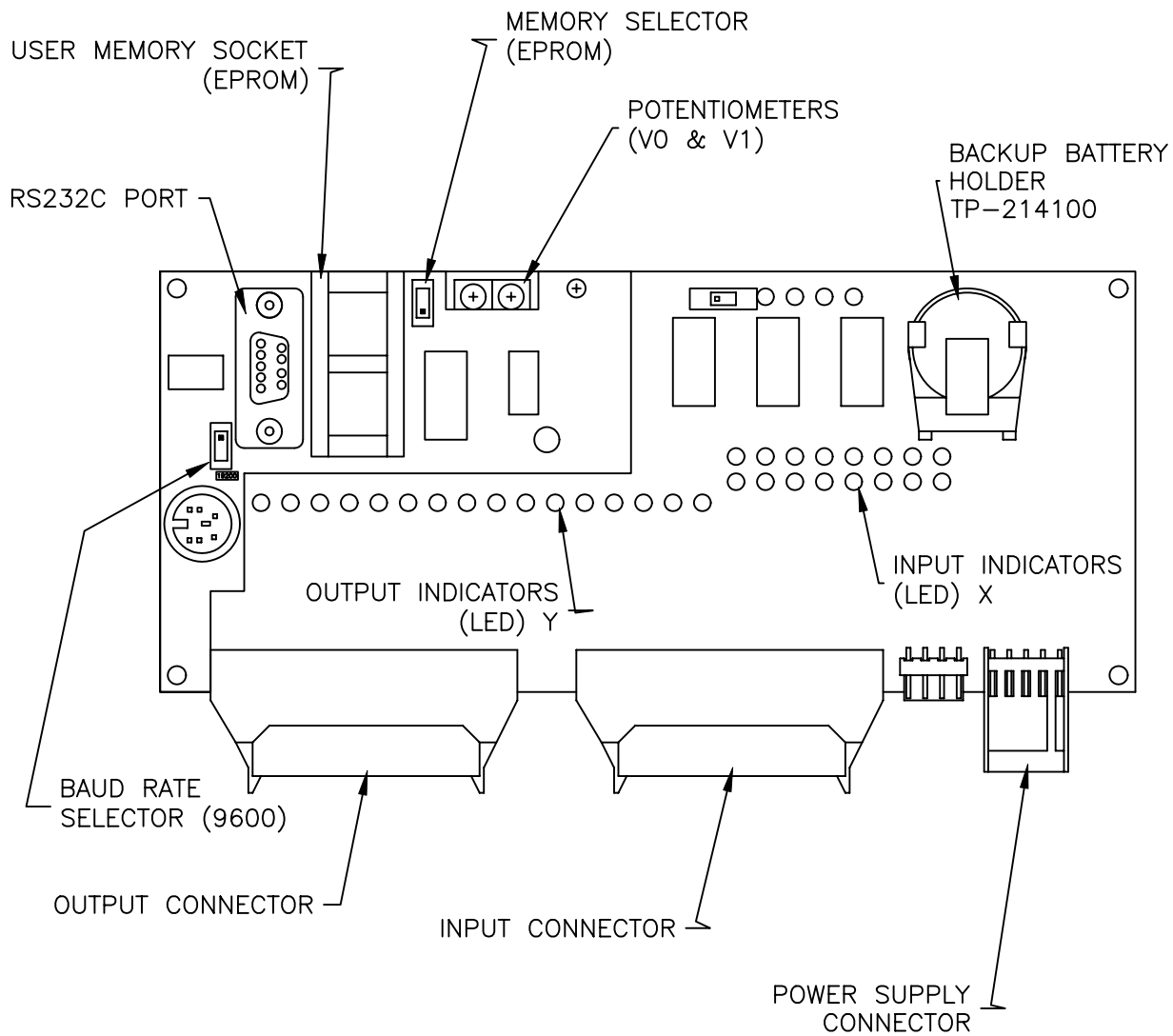

PLC  
TP-220367

FIGURE 4-8



Advanced  
Poly Packaging Inc.

1331 Emmitt Road \* Akron \* Ohio 44306  
Phone: 330-785-4000 \* Fax: 330-785-4010

TYPE EQUIPMENT T-1000	B/M REF. NO.	PART NO.
SCALE 1:1	DRAWN BY NAME MELODY DATE 10/24/00	APPROVED NAME DATE

NOTICE: THIS DOCUMENT CONTAINS PROPRIETARY INFORMATION AND IT SHALL NOT BE USED OR REPRODUCED OR ITS CONTENT DISCLOSED, IN WHOLE OR PART, WITHOUT THE PRIOR WRITTEN CONSENT OF ADVANCED POLY-PACKAGING INC.

TITLE PLC CONTROLLER BOARD	DRAWING NO. TP-T1E10	REV.
-------------------------------	-------------------------	------

### Input Indicators (LEDs) X

0	Heater Bar Temperature Readout (Thermocouple)
1	Reserved
2	Reserved
3	Anti-Jam Sensor (Pressure Bar)
4	Foot Switch
5	Perf Sensor Position (P.S. Board)
6	Auxiliary Input Signal (Dump product)
7	Anti-Jam Over-ride Sensor (Pressure Bar)
8	Palm Button (Left)
9	Palm Button (Right)
A	Inner Frame Open Sensor
B	Open Thermocouple Alarm (Caution: Should never be lit)
C	Printer (No Foil) Alarm
D	Counting-Funnel Sensor (Auto Detect)
E	Printer (Busy)
F	Bag out (no bags)

### I.F. Board Lights (Fig. 4-9)

E1	Clutch	Green
E2	Brake	Red
E3	Drive Motor	Green
E4	Heater	Amber
E5	Printer	Clear
E6	Auxiliary	Red
E7	Palm Button (Left)	Red
E8	Palm Button (Right)	Red
E9	Optical Sensor (In)	Red
E10	Printer (No foil)	Red
E11	Auxiliary 3	Red
E12	Reserved	Red
E13	Open Thermocouple Alarm	Red
N1	Perf Sensor AC	Neon
N3	Motor AC	Neon
N4	Heater Pulse AC	Neon
N5	Printer AC OFF	Neon
N6	Brake DC	Neon
N7	Clutch DC	Neon

### I.F. Board Fuses (Fig. 4-10)

F1	D.C. Power Supply	2.5 AMP
F2	Clutch	1 AMP
F3	Brake	1 AMP
F4	Motor	3.15 AMP
F5	Heater	10 AMP
F6	Auxiliary	3.15 AMP



# INTERFACE BOARD LIGHTS

## TP-200348

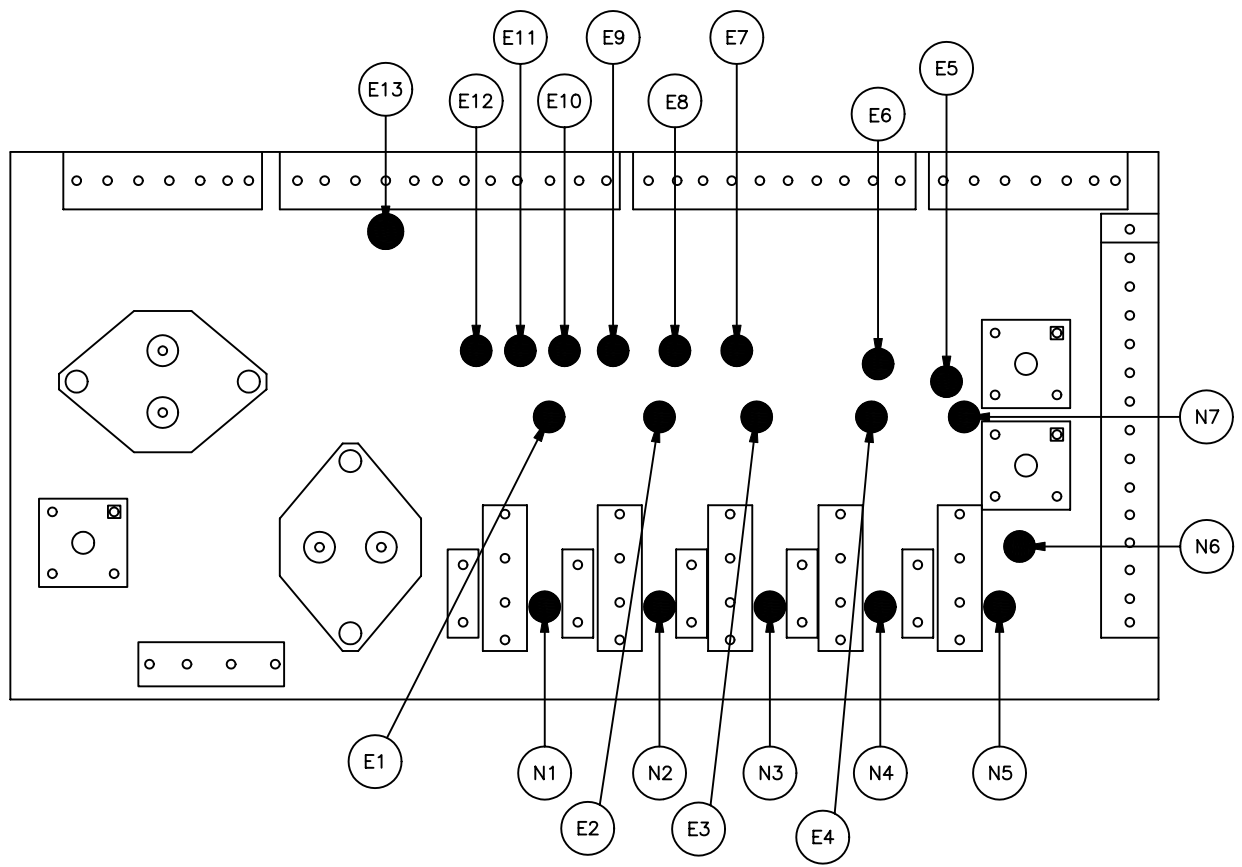

FIGURE 4-9



Advanced  
Poly Packaging Inc.

1331 Emmitt Road \* Akron \* Ohio 44306  
Phone: 330-785-4000 \* Fax: 330-785-4010

TYPE EQUIPMENT T-1000	B/M REF. NO. ELECTRICAL ASSEMBLY	PART NO.
SCALE FULL	DRAWN BY NAME MELODY DATE 10/25/00	APPROVED NAME DATE

NOTICE: THIS DOCUMENT CONTAINS PROPRIETARY INFORMATION AND IT SHALL NOT BE USED OR REPRODUCED OR IT'S CONTENT DISCLOSED, IN WHOLE OR PART, WITHOUT THE PRIOR WRITTEN CONSENT OF ADVANCED POLY-PACKAGING INC.

TITLE I.F. BOARD LIGHT DIAGRAM	DRAWING NO. TP-T1L01	REV.
--------------------------------------	-------------------------	------

# INTERFACE BOARD FUSES

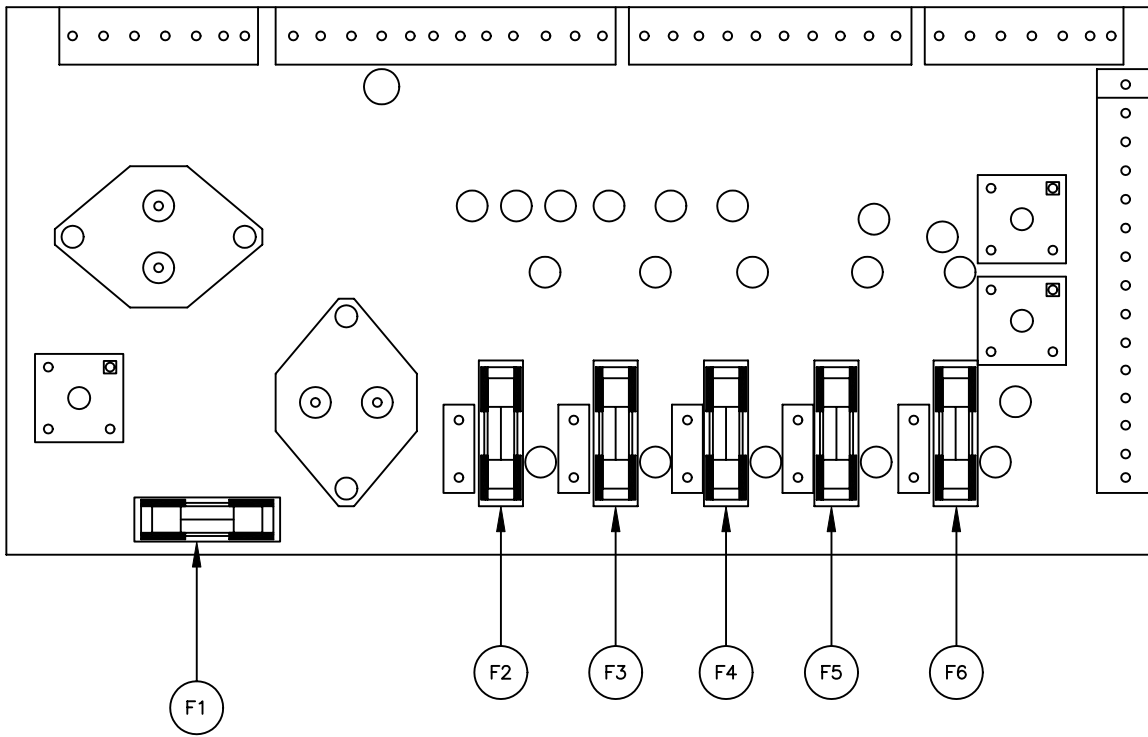

F1:FUSE – TP-207206

F2 – TP-207225

F3 – TP-207225

F4 – TP-207226

F5 – TP-207228

F6 – TP-207226

FIGURE 4-10



Advanced  
Poly Packaging Inc.

1331 Emmitt Road \* Akron \* Ohio 44306  
Phone: 330-785-4000 \* Fax: 330-785-4010

TYPE EQUIPMENT T-1000	B/M REF. NO. ELECTRICAL ASSEMBLY	PART NO.
SCALE FULL	DRAWN BY NAME MELODY DATE 10/25/00	APPROVED NAME DATE

NOTICE: THIS DOCUMENT CONTAINS PROPRIETARY INFORMATION AND IT SHALL NOT BE USED OR REPRODUCED OR ITS CONTENT DISCLOSED, IN WHOLE OR PART, WITHOUT THE PRIOR WRITTEN CONSENT OF ADVANCED POLY-PACKAGING INC.

TITLE I.F. BOARD  
FUSE DIAGRAM

DRAWING NO.  
TP-T1L02

REV.

## I.F. Board Connectors (Fig. 4-11)

See wiring diagram for connectors identification (J1 - J5)

## Perf Sensor (P.S.) Board (Fig. 4-12)

E1	Armed Sensor Light	Green
E3	Perf Detected Light	Red
R9	Perf Sensor Sensitivity Adjustment	Factory set only
H1	Jumper Settings	Jumper 1 / 2 (normal)
J1 - J4	Connectors	See wiring diagram

## 7.6 Pneumatic Valves / Cylinders

Pneumatic Piping Diagram (Fig. 4-13)

SAV1	Pressure Bar Sol Valve	Main Seal Cylinder
SAV2	Heat Bar Sol Valve	Seal Bar Cylinders (2)
SAV3	Load Shelf Sol Valve (Option)	Load Shelf Cylinder
SAV4	Load Shelf Sol Valve (Option)	Bag Lift Cylinder
SAV5	Trim Seal Sol Valve (Option)	Trim Blower
SAV6	Tear Off Sol Valve	Tear Off Cylinder
SAV7	Flat Seal Sol Valve (Option)	Flat Seal Cyl.
SAV8	Accum. Funnel (Option)	Accum. Funnel Cylinder
SAV9	Blower Valve	Blower
SAV10	Air Pulse Valve	Air Pulse

# INTERFACE BOARD CONNECTORS

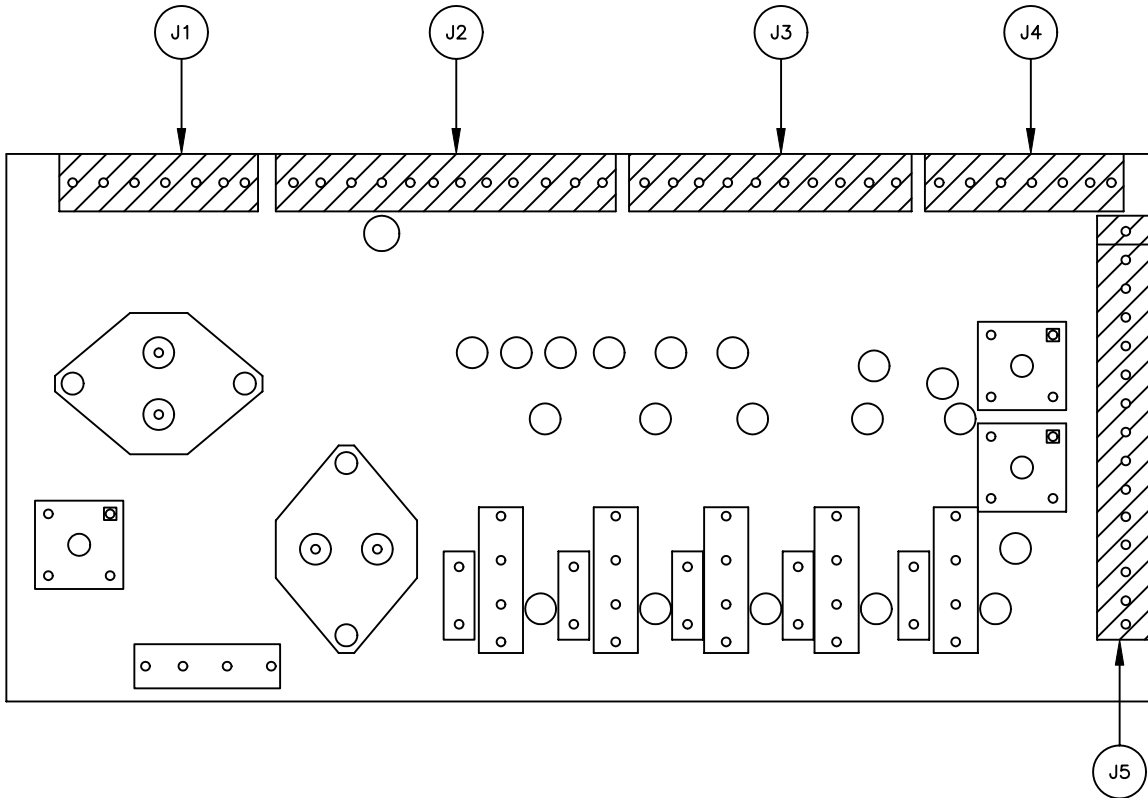

- J1 — TP-212130
- J2 — TP-208131
- J3 — TP-208133
- J4 — TP-212130
- J5 — TP-208132

FIGURE 4-11



Advanced Poly Packaging Inc.

1331 Emmitt Road \* Akron \* Ohio 44306  
 Phone: 330-785-4000 \* Fax: 330-785-4010

TYPE EQUIPMENT T-1000		B/M REF. NO. ELECTRICAL ASSEMBLY	PART NO.
SCALE FULL	DRAWN BY NAME MELODY DATE 10/25/00	APPROVED NAME DATE	

NOTICE: THIS DOCUMENT CONTAINS PROPRIETARY INFORMATION AND IT SHALL NOT BE USED OR REPRODUCED OR ITS CONTENT DISCLOSED, IN WHOLE OR PART, WITHOUT THE PRIOR WRITTEN CONSENT OF ADVANCED POLY-PACKAGING INC.

TITLE I.F. BOARD TREMINAL STRIP CONNECTOR DIAGRAM	DRAWING NO. TP-T1L03	REV.
---	-------------------------	------

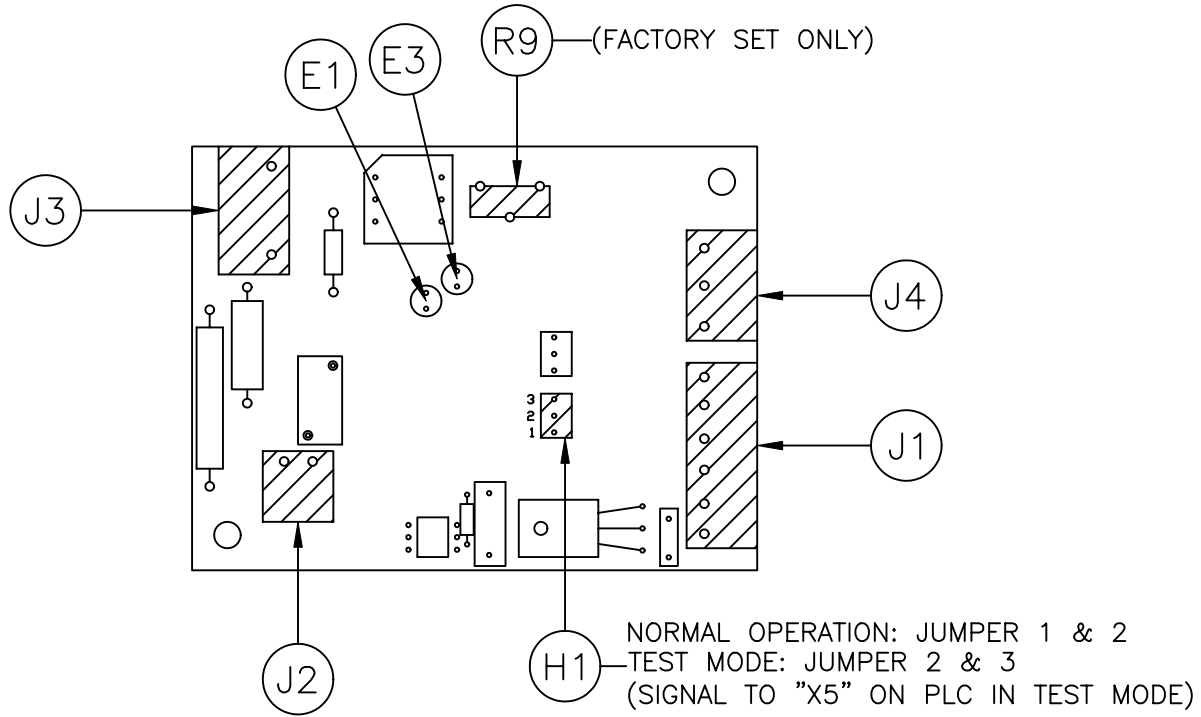

**WARNING:** HIGH VOLTAGE  
 DISCONNECT POWER CORD PRIOR  
 TO REMOVING LEFT SIDE COVER.

TRANSFORMER w/SHIELD – TP-211384

BOARD H.V. – TP-220408

FIGURE 4-12



Advanced  
 Poly Packaging Inc.

1331 Emmitt Road \* Akron \* Ohio 44306  
 Phone: 330-785-4000 \* Fax: 330-785-4010

TYPE EQUIPMENT T-1000		B/M REF. NO.	PART NO.
SCALE FULL		DRAWN BY NAME MELODY DATE 10/25/00	APPROVED NAME DATE
TITLE PERF SENSOR BOARD		DRAWING NO. TP-T1L04	REV.

NOTICE: THIS DOCUMENT CONTAINS PROPRIETARY INFORMATION AND IT SHALL NOT BE USED OR REPRODUCED OR ITS CONTENT DISCLOSED, IN WHOLE OR PART, WITHOUT THE PRIOR WRITTEN CONSENT OF ADVANCED POLY-PACKAGING INC.

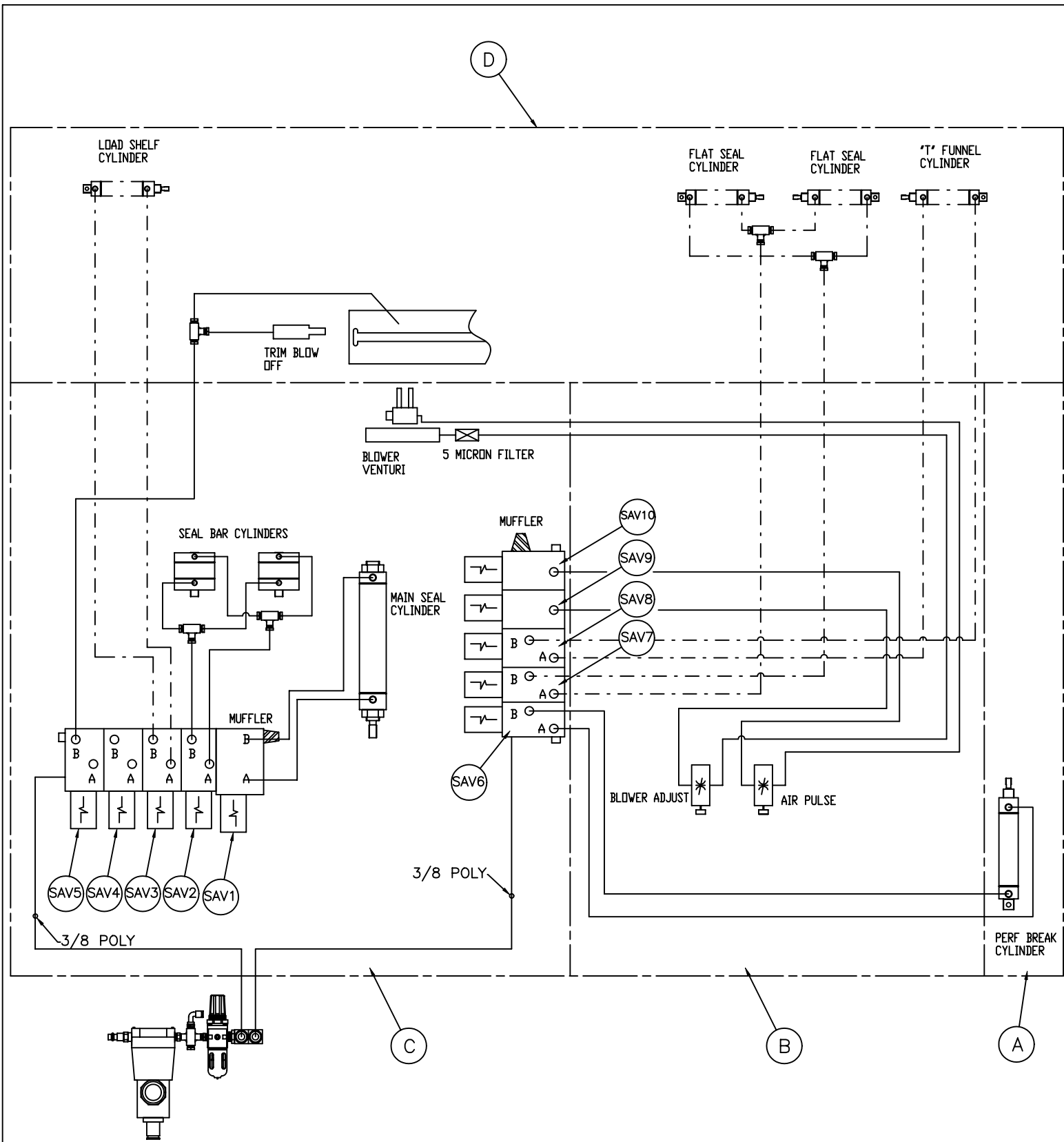

LOCATION:  
 A: RIGHT SIDE PANEL  
 B: INSIDE FRAME  
 C: LEFT SIDE PANEL  
 D: FRONT OF MACHINE

REPRESENTS  
 OPTIONAL  
 EQUIPMENT - - - - -

FIGURE 4-13

**SEMPAC** Advanced Poly Packaging Inc.

DRAWING TITLE: MODEL T-1000 PNEUMATICS PIPING DRAWING

DRAWN BY: MELODY	DATE: 10/30/01	DRAWING NO.	SHEET: 1 OF 1
CHKD. BY: -	DATE: -	SCALE: NTS	TP-T1M



