

T-275 Automatic Table-Top Bagger/Sealer

Operation Guide, Version 4 - TM-T8-75MANV4
Setup, Operation and Parts Manual

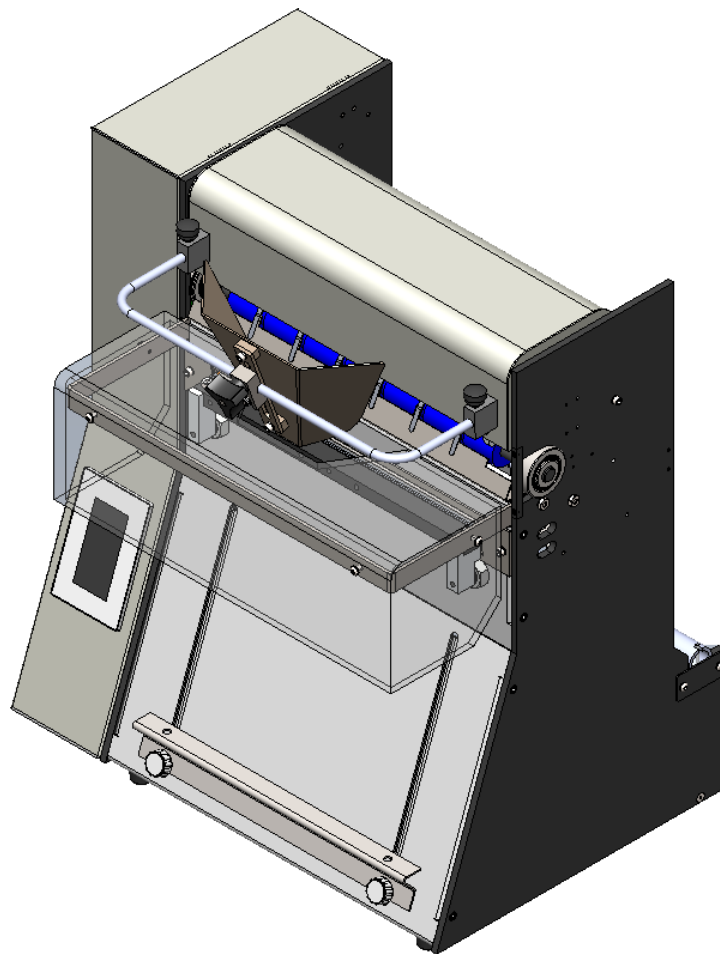

 **Advanced
Poly-Packaging, Inc.**

1331 Emmitt Road • Akron, OH 44306 • 1-800-754-4403 • fax 330-785-4010 • www.advancedpoly.com

Acknowledgments

Written By: Annie Bradock, updated by David Kolinski-Schultz
Reviewed By: Stuart Baker

Copyright

2001 (Version 1), 2002 (Version 2), 2014 (Version 3), 2018 (Version 4) Advanced Poly-Packaging, Inc. (APPI). All rights reserved.

This manual and the program operating the equipment described in it are copyrighted. You may not copy this manual in whole or part without the consent of Advanced Poly-Packaging, Inc.

All information pertaining to the promotion, sale, distribution, operation and maintenance of the T-275 Tabletop Bagger/Sealer including this manual, drawings, schematic, wiring diagrams, videos, brochures, specification sheets, figures, charts, or any other information, due to its proprietary design and manufacture remain the property of Advanced Poly Packaging, Inc. Unauthorized duplication, distribution or disclosure to third parties without the express permission of Advanced Poly-Packaging, Inc. is strictly prohibited.

Trademarks

T-275 is a trademark of Advanced Poly-Packaging, Inc. Advanced Poly-Packaging, Inc. owns also the following trademarks: Advanced Poly-Bags, Advanced Poly-Bagger, Seal-a-Print, Roll-a-Print, Twin-Seal, Advanced Poly-Pack, Advanced Poly-Bag, and Advanced Bag.

Limited Warranty and Disclaimer

Warranty period is 12 months or 1,000,000 cycles whichever comes first. The warranty commences on the date of delivery of the equipment to the Purchaser. APPI warrants to the Purchaser that the equipment is free from defects in workmanship or material under normal use and service. During the warranty period, APPI agrees to repair or replace, at its sole option, without charge to Purchaser, any defective component part of the equipment. To obtain service, Purchaser must return the equipment or component to APPI or an authorized APPI distributor or service representative in an adequate container for shipping. Any shipping charges, insurance, or other fees must be paid by Purchaser and all risk for the equipment shall remain with Purchaser until APPI takes receipt of the equipment. Upon receipt, APPI, the authorized distributor or service representative will promptly repair or replace the defective component and then return the equipment or component to Purchaser, shipping charges, insurance, and additional fees prepaid. APPI may use reconditioned or like new parts or units, at its sole option, when repairing any component or equipment. Repaired products shall carry the same amount of outstanding warranty as from original purchase. Any claim under the warranty must include a dated proof of delivery. In any event, APPI's liability for defective components or equipment is limited to repairing or replacing the components. This warranty is contingent upon proper use of the equipment by Purchaser and does not cover: expendable component part such thermocouple wire, Heater Cartridge, rollers, bushings, and the like; or if damage is due to accident, unusual physical, electrical or electromechanical stress, neglect, misuse, failure of electric power, water damage (from airlines), improper environmental conditions, transportation, tampering with or altering of the equipment, packaging of corrosive or contaminating products or other products damaging to components, and equipment or components not owned or in the possession of original Purchaser. APPI will not be liable for loss of production, profits, lost savings, special, incidental, consequential, indirect, or other similar damages arising from breach of warranty, breach of contract, negligence, or their legal action even if APPI or its agent has been advised of the possibility of such damages or for any claim brought against the Purchaser by another party. This warranty allocates risks of equipment failure between Purchaser and APPI. APPI's pricing reflects this allocation of risk and the limitations of liability contained in this warranty. The warranty set forth above is in lieu of all other express warranties, whether oral or written. The agents, employees, distributors, and dealers of APPI are not authorized to make modifications to this warranty, or additional warranties binding on APPI. Accordingly, additional statements such as dealer advertising or presentations, whether oral or written, do not constitute warranties by APPI and should not be relied upon. Warranty on equipment is considered void when outstanding balances become delinquent (over 30 days late - 60 days after ship date). Equipment Integration to other Equipment: APPI assumes no responsibility for the integration of its products to other products or within a system unless APPI performs the integration, testing and provides the results of the tests to the purchaser in writing. Furthermore, APPI assumes no responsibility for bag sizing whether suggested or recommended.

Table of Contents

Chapter 1: Introduction	4
1.1 Welcome	5
1.2 Overview	5
1.3 Standard Features	5
1.4 Available Options	6
1.5 Using this Manual - Typographical Conventions	6
1.6 Contact Information	7
1.7 Warranty Registration	8
Chapter 2: Safety, Getting Started	10
2.1 Chapter Summary	11
2.2 Safety, Risks	11
2.3 Installation Procedures	12
2.4 Note on Adjustments to the T-275	12
2.5 Air and Power Requirements	12
2.6 Air and Power Hookup	13
2.7 Main Power	13
2.8 Bag Roll Mounting and Threading	13
2.9 Operation/Component Tests Prior to Production	17
2.10 Heat / Seal Time Setting	17
2.11 Air / Seal Pressure Adjustments	17
2.12 Air Pulse / Blower Adjustment	17
2.13 Funnel Position	18
2.14 Cycle Operation Methods	18
2.15 Adjustable Shelf	18
2.16 Pull Tension Adjustments	18
2.17 Note on Seal Quality	19
2.18 Totalizing Counter	19
Chapter 3: Touch Screen Operation	20
3.1 Touch Screen Specifications	21
3.2 Touch Screen Program, Overview	21

3.3	Introductory Screen / Technical Assist Screen	21
3.4	Main Menu.....	22
3.5	Settings Screen.....	23
3.6	Seal Settings Screen.....	23
3.7	Options Screen.....	24
3.8	Job Save Function / Screen	26
3.9	Message Screens / Information Screens	27
Chapter 4: Adjustments Maintenance, Troubleshooting		30
4.1	Machine Adjustments	31
4.2	Adding PTFE to Rubber Strip and Cleaning	31
4.3	Rubber Strip Replacement	31
4.4	PTFE Spool Advancement.....	32
4.5	PTFE Sheet Replacement	32
4.6	Heater Cartridge Replacement.....	34
4.7	Description of Anti-Jam Circuit.....	35
4.8	Anti-Jam Adjustments / Testing	35
4.9	Preventative Maintenance.....	39
4.10	Recommended Spare Parts List	40
4.11	Schematics	40
Chapter 5: Parts and Drawings		44
5.1	Parts Component Identification	45
5.2	T-T275 Tabletop Bagger System Layout	45
5.3	Electronics Assembly.....	46
5.4	Mechanical Assembly.....	48
5.5	Heater Bar Assembly	52
5.6	Notes	54

Chapter 1: Introduction

Welcome

Overview

Standard Features

Available Options

Using this Manual - Typographical Conventions

Contact Information

Warranty Registration

1.1 Welcome

Now that you have decided to upgrade your packaging facilities with the T-275 Tabletop Bagger/Sealer from Advanced Poly-Packaging, Inc., we thank you for selecting our equipment, materials, and service. Where labor reduction and fast changeover are important, the T-275 uses Advanced Poly-Bags (pre-opened bags on rolls) manufactured by Advanced Poly-Packaging, Inc. Extensively equipped with several "built-in," ready-to-use options, the T-275 can package various industrial, medical, molded and food products. With bag sizes that range from 2" x 2" to 11" x 16" and mil thickness from 1 mil to 5 mil, we hope the T-275 will meet all your bagging needs.

1.2 Overview

The T-275 is designed to lower your packaging costs with increased speeds, versatility, reliability, and simplicity. Instead of sealing with a conventional jaw sealer, which requires operators to pull individual bags from a carton and then open the bag before inserting components; the T-275 Bagger / Sealer is designed for pre-opened bags to open immediately after automatically indexing into position. The seal position can easily be raised or lowered on the bag and once loaded, the bag can be sealed without having to separate the bag at the perforation. Simple touch screen control allows for a quick and easy setup.

High Speeds: Indexes, opens, seals, and tears off a bag at very high rates of speed. Actual packaging speed depends on the bag size, equipment options, product characteristics and loading method.

Versatility: Bags virtually any product including fasteners, hardware, injection molded parts, kits, crafts, foods, medical devices and more. Runs bags produced from LDPE, LLDPE, HDPE, Foil, Polypropylene, Tyvek™ and various barrier films. The T-275 Automatic Tabletop Bagger/Printer™ is ideal for short runs where product, bag size or print changes are performed in minutes.

Reliability: Crafted from the highest quality components and materials to withstand the most rigorous manufacturing environment. Sturdy mounts with castors and a rugged frame guarantee long life and usefulness with minimal maintenance.

Simplicity: A user-friendly, menu-driven touch screen program allows operators to set up the bag, options, and auxiliary equipment, save settings in memory and recall those settings for repeat runs.

1.3 Standard Features

The T-275 has been designed with simplicity of operation and ease of maintenance in mind. Threading is easy with a lift and thread operation. There are no rollers to thread around so the chance of mis-threading is eliminated. A user-friendly touch screen program provides quick setting adjustments and job saves. A totalizing counter and preset counter is provided to keep track of the total bags per shift, day or job and allows for halting operation to change boxes or part numbers.

Patented design seal assembly (PTFE Anti-Stick Sheet): PTFE is only in contact with Heater Bar during sealing and is then stripped away from the heater bar immediately after sealing. This reduces contamination buildup, increases PTFE life, and improves seal integrity.

Patented Anti-Jam Device: During the loading and sealing operation, this device detects obstructions and automatically reverses the Pressure Bar, discounting the cycle operation.

1.4 Available Options

Although the T-275 is equipped with many standard features, additional available options are recommended to improve up-time, production, and safety. The following options may be purchased from Advanced Poly-Packaging, Inc:

Spare Parts Kit: Additional PTFE, Heater Cartridge, valves, and other components make this kit a must.

Special Funnels: Send us your product and we will evaluate the loading to determine the best funnel design.

Bag Deflator: Quickly mounts to the sealer bar, squeezing the air from the bag while sealing.

CS-10 Compartment Seal: Seals the bag twice with compartments within the same bag.

CF-10 Counting Funnel: This option automatically cycles the bagger when a preset number of parts have fallen through the funnel.

LC-10 Light Safety Curtain: If funnels are removed, APPI highly recommends the addition of this option to prevent injuries. This option, when activated, prevents inputs to valves that cause the Seal Bar to activate. Additionally, the stepper motor stops when blocked.

Other options may have been added since the date this list was printed. Please call for additional or custom options pricing.

1.5 Using this Manual - Typographical Conventions

The following manual conventions are frequently used to assist in understanding important information, alerting the operator of potentially dangerous or damaging practices, and the normal functions of the

T-275 Tabletop Bagger / Sealer.

text Normal text

<ENTER> Used to show Touch Screen keys

Italics Used for emphasis

Note: Identifies important information.

CAUTION: Warning messages - To avoid physical harm, damage to equipment or damage to the product. Be sure to read these messages carefully.

1.6 Contact Information

To better serve your bagging needs, call **(330) 785-4000** or toll free **1-(800) 754-4403** for convenient service solutions, Monday through Thursday, 9:00 AM to 5:30 PM EST, or Friday 9:00 AM to 5:00 PM EST. For technical assistance with current machinery, ask for **Service**. To order spare parts for your system, ask for **Parts**. To order auxiliary equipment for your current system, ask for **Machine Sales**. To place an order for bags, ask for **Bag Sales**.

You may also contact any of these departments by email:

Reach Service at Service@advancedpoly.com

Reach Parts at Parts@advancedpoly.com

Reach Machine Sales at MachineSales@advancedpoly.com

Reach Bag Sales at Bagsales@advancedpoly.com

For general inquires: Sales@advancedpoly.com

Or visit us online at www.advancedpoly.com

To provide the best service possible, please have model and serial number ready.

1.7 Warranty Registration

This section must be completed and returned to Advanced Poly-Packaging, Inc. to register the T-275 Tabletop Bagger/Sealer for Warranty Protection.

Serial Number:

(Serial Number located on the back panel)

Company Name and Address

Contact Name(s) / Title(s) / Phone Number

<hr/> <hr/> <hr/>	<hr/> <hr/> <hr/>
-------------------	-------------------

Please fax or mail this page to:

Service Manager
Advanced Poly-Packaging, Inc.
1331 Emmitt Road
Akron, OH 44306
USA

Fax # (USA) 330-785-4010

Or email the information above to: service@advancedpoly.com

This page intentionally left blank

Chapter 2: Safety, Getting Started

Chapter Summary

Safety, Risks

Installation Procedures

Note on Adjustments to the T-275

Air and Power Requirements

Air and Power Hookup

Main Power

Bag Roll Mounting and Threading

Operation/Component Tests Prior to Production

Heat / Seal Time Setting

Air / Seal Pressure Adjustments

Air Pulse / Blower Adjustment

Funnel Position

Cycle Operation Methods

Adjustable Shelf

Pull Tension Adjustments

Note on Seal Quality

Totalizing Counter

2.1 Chapter Summary

This chapter describes procedures to receive and set up the T-275, including uncrating instructions, environmental, air and power requirements, risks, required safety precautions, quick start procedures assembly instructions and height adjustments. Additionally, this chapter describes safety precautions, how to power on the T-275 and how to properly thread bags through the machine.

2.2 Safety, Risks

The equipment has been designed with features to reduce the possibility of injury. Despite safety precautions, operators may receive lacerations, minor burns or crushed or broken bone injuries if coming in contact with the Heater Bar or other moving components. Please carefully read the following precautions to operate the equipment properly and avoid injury.

Although no special personal protective equipment is required to operate the equipment, eye protection, gloves or other protection should be worn depending on the characteristics of product being packaged or the method of loading the product.

Please carefully read the following precautions to operate the equipment properly and avoid injury:

CAUTION: Initial Setup of the machine must be performed by Specialized Personnel. Qualified Service Engineers should uncrate, assemble (if required), test and connect power sources, test the equipment for proper operation and otherwise setup the equipment for use.

CAUTION: Maintenance must be performed by Specialized Personnel. Qualified Service Engineers must remove guards or covers to gain access to electrical or mechanical areas.

CAUTION: To avoid injury do not reach under the equipment or guards. Do not place hands or fingers in the seal area, near the seal or heater bar, load shelf, or other moving components.

CAUTION: To avoid injury, do not operate the equipment if funnels, guards, or covers or other access panels have been removed. If any of these safety measures have been removed or modified or if any openings have been increased, the operator will have access to moving components and extreme temperature areas that can cause crush, cut, or burn injuries to hands or fingers.

CAUTION: Ensure that any height adjustments allow for sufficient movement of the operator. Improper height adjustments could negatively affect operator movement, causing strain, added stress, discomfort, and fatigue.

CAUTION: Be careful when opening the Seal Frame as it may drop suddenly causing injury or damage to the equipment.

CAUTION: To avoid injury, avoid coming in contact with pinch points including rollers, automatic funnel doors or other moving components.

CAUTION: To avoid injury, avoid contact with Roller "Fingers" as they may be sharp.

CAUTION: If control or air pressure settings are set too high, higher noise levels may result from increased part on part contact or part on machinery contact. Limit these settings and add guards or covers to reduce airborne noise.

CAUTION: Exercise extreme care when clearing jams, replacing materials, changing controls or mechanical settings, and cleaning internal parts. Be sure to de-energize energy sources prior to removing guarding. Failure to do so may result in unexpected movement or flying objects, which could cause crush, cut, or eye injuries.

CAUTION: Maintenance must be performed regularly to ensure that the machine is operating properly and to protect against injury. Routine maintenance includes: periodic inspections, the replacement of worn or damaged components, the tightening of loose bolts or components, and regular cleaning and adjustments. Contact APPI and/or service centers for service support if there is not sufficient maintenance staff at your facility to perform regular maintenance.

2.3 Installation Procedures

The T-275 is shipped completely assembled and in a carton or crate. Remove all tape, banding or packing materials that secure the machine. To ensure the highest production possible, consider product flow to the bagger and packaged product flow away from the bagger when positioning the bagger into your packaging areas.

Operating Environment: The T-275 should be placed in an area free of excessive heat, moisture, dirt, and dust. Operating room temperature should range from 50°F to 100°F (10°C to 37.77°C).

2.4 Note on Adjustments to the T-275

Upon receipt, it is not unusual for the T-275 to be out of alignment due to shipping and excessive handling. Unless physically damaged, the T-275 will function properly after minor adjustments are made. Refer to Chapter 4 for information on adjustments to the T-275.

2.5 Air and Power Requirements

Power Requirements: Provisions must be made for 115 VAC, 50/60 Hz line current with ground. The full load current for the T-275 is 5 Amps. APPI recommends a dedicated 20 Amp circuit for the T-275.

Air Requirements: At least 2 CFM free air is required, regulated to 60 PSI (413.68 kPa). Air should be dry and oil-free.

Note: Running the T-275 at a higher PSI setting than 60 PSI (413.68 kPa) will cause excessive wear and may cause damage to components on the machine or parts being packaged. The Anti-Jam function may also be adversely affected.

2.6 Air and Power Hookup

This section describes how to hookup air and power and the air and power requirements.

Note: *A qualified electrician should ensure power outlets are the required 115 VAC and properly grounded before hooking up power. If the unit is not properly grounded, it will produce a shock and the machine will not work properly.*

The T-275 is equipped with an internal regulator and the air supply should be fed to the bagger with 1/4" minimum O. D. poly tubing. Make the connection at the rear of the sealer. Set the air pressure on the T-275 between 50 PSI (344.738 kPa) and 70 PSI (482.633 kPa) using the Regulator Adjust and Gauge. Use the lowest possible pressure setting to achieve consistent seals. See Figure 2-1.

CAUTION: *Do not use lower than the minimum and no higher than 70 PSI. Higher pressures may cause further injury to fingers in seal area. To avoid injury, do not reach into the seal area.*

Insert the T-275 power cord into a 115 VAC, 60 Hz, grounded power outlet.

2.7 Main Power

The main power switch is located on the back cover of the machine. See Figure 2-2. To turn the T-275 on, press the Rocker Switch. In the ON or "up" position, the switch is illuminated indicating that power is supplied to the unit.

CAUTION: *A certified electrician should ensure the incoming power is the correct voltage and is grounded before connecting the T-275.*

CAUTION: *Do not remove cover or attempt to operate with covers removed or wires exposed.*

2.8 Bag Roll Mounting and Threading

Remove the roll shaft from the rear of the machine. Loosen one of the knobs located on the chuck which secures the roll into position. Mount the roll of bags onto the bag roll shaft and secure the bag roll into position with the chuck. With the loose web of bags falling over the rear of the roll, insert the web into the slot above the stainless rear cover and below the top cover.

With the web of bags positioned under the top cover, raise the top cover of the T-275 by lifting the funnel mounting rods. Pull the web forward through the cover while lowering the top cover. When the top cover is lowered, the first bag should open by the airflow.

The roll shaft is fixed into position with a pin and will not spin. The roll should freely turn on the shaft. However, tension can be added to the web of bags by loosening one knob, squeezing the roll of bags with the two chucks, and tightening the knob. Do not apply too much tension or the web of bags may prematurely break as they are feeding through the machine. See Figure 2-3.

CAUTION: *Roller "fingers" may be sharp. To avoid injury when reaching into the T-275, ensure that you do not come in contact with the roller fingers.*

Air Input & Regulator

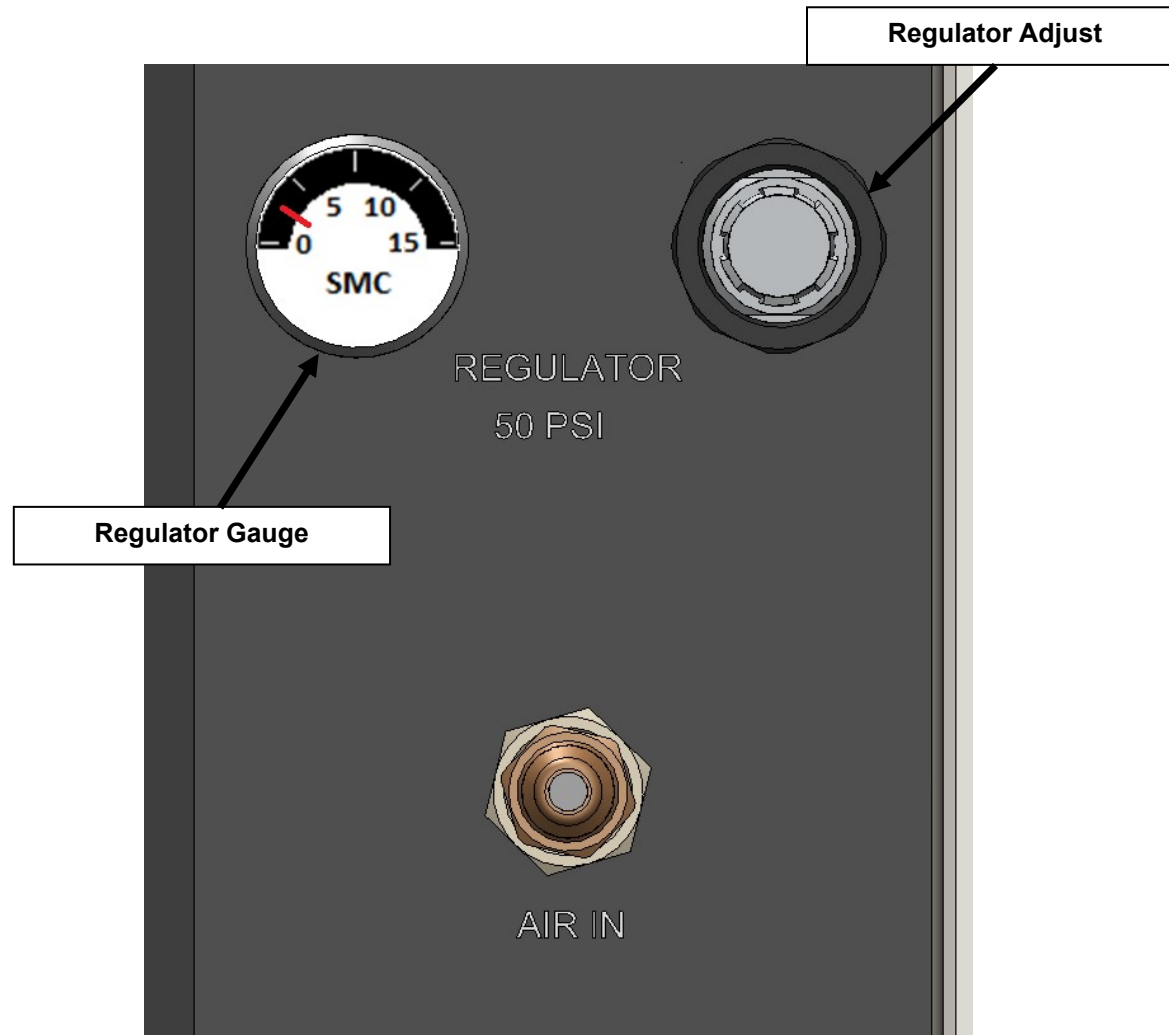

Figure 2-1

T-275 Control Panel

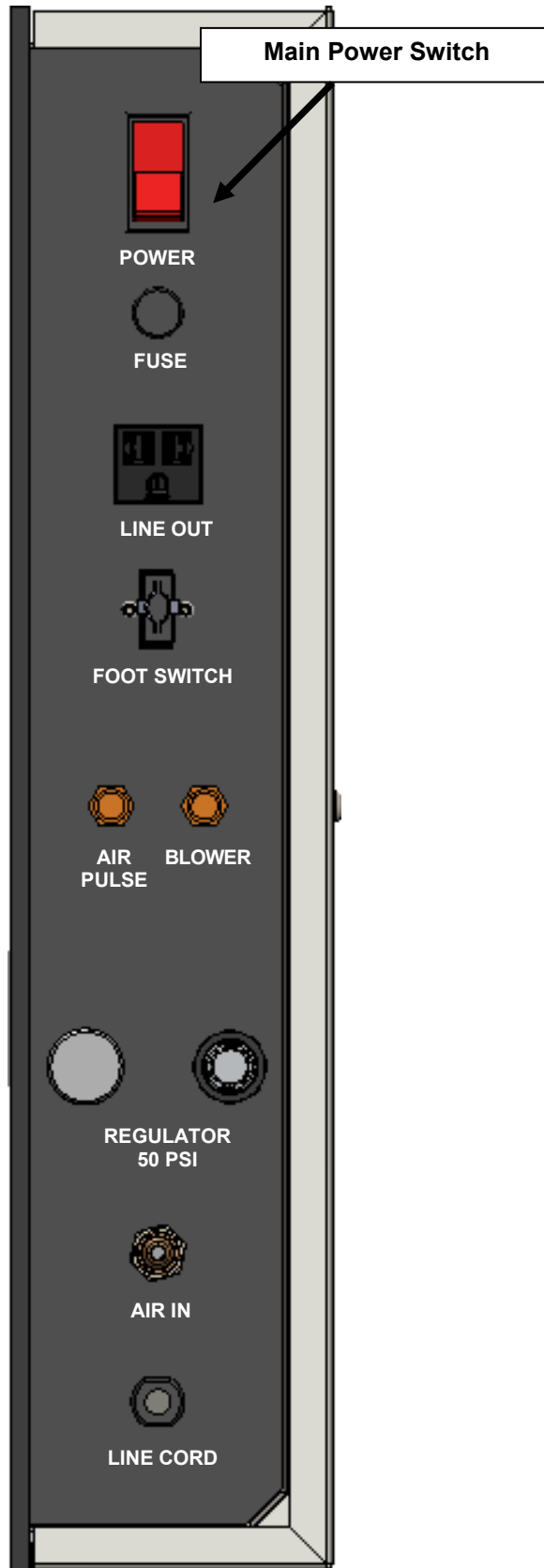

Figure 2-2

Threading Diagram

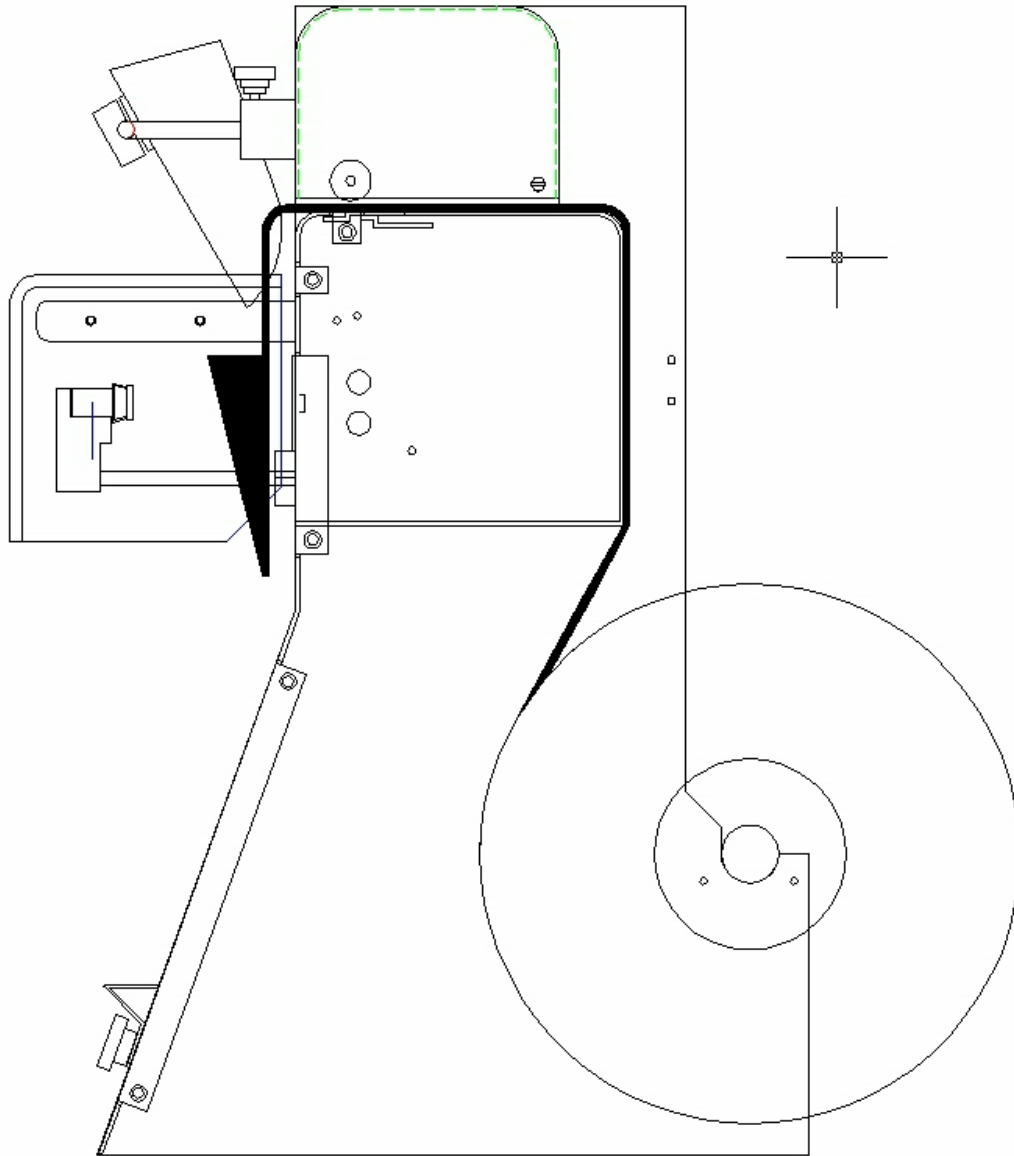

Figure 2-3

2.9 Operation/Component Tests Prior to Production

A patented Anti-Jam circuit is provided as a standard feature of the T-275. When properly set, this feature provides some degree of safety to the product and equipment.

CAUTION: The Anti-Jam feature should not be considered a safety feature since improper adjustment or malfunction could cause injury.

Prior to beginning production, the Anti-Jam mechanism should be tested as follows:

Test 1: With air applied and the power on, position an object over 1/4" in thickness (a pen or pencil for example) on the far-left side of the Seal Bar with the object in contact with the PTFE Shield, but not pressing in the spring-loaded "U" channel PTFE Shield. Then press the foot switch. The Anti-Jam circuit is working properly if the Pressure Bar retracts. If the Pressure Bar does not immediately retract, do not begin production, and refer to Chapter 4.7 for instructions on Anti-jam Adjustments.

Test 2: With air applied and the power on, position an object over 1/4" in thickness (a pen or pencil for example) on the far-left side of the Seal Bar with the object pushing inward on the PTFE Shield. Ensure that you are pressing in the spring-loaded "U" channel PTFE Shield and then press the foot switch. The Anti-Jam circuit is working properly if the Pressure Bar does NOT move inward. If the pressure moves inward, do not begin production, and refer to Chapter 4.7 for instructions on Anti-Jam adjustments. Continue these test procedures with the object being moved along the entire seal area length from the left to the right side of the seal area.

CAUTION: To avoid injury or damage to components, do not operate the T-275 if the Anti-Jam is out of adjustment or is malfunctioning.

2.10 Heat / Seal Time Setting

The higher the temperature, the less time is required, the lower the temperature, the more time is required.

2.11 Air / Seal Pressure Adjustments

To obtain good consistent seals, air pressure must be adjusted. The pressure valve is located on the rear of the unit. Typically, the air pressure is set to a constant pressure of 60 to 70 PSI. To increase the pressure, pull the black knob upward and turn clockwise. Then, push the knob inward to lock into position. To decrease pressure, pull the knob upward, turn counter-clockwise and press to lock.

2.12 Air Pulse / Blower Adjustment

The T-275 is equipped with a 6" wide Air Knife and Flow Control Valve to ensure that the bags blow open quickly and consistently. Since the Air Knife speeds up air, compressed air is conserved. Adjust the volume of air with the blower Flow Control Valve located on the rear of the unit (bronze knob). To slow down or reduce the volume of air, turn the knob counter-clockwise; to increase the air flow, turn the knob clockwise. Begin by turning the blower all the way down and increase slightly until the bags blow open continuously and consistently. Once adjusted, there is a locking nut to prevent the knob from loosening.

NOTE: Excessive air flow will cause the bag to move around and product to possibly spill from the bag.

CAUTION: *If the blower is set to high, light product may be blown out of bag causing eye injury. Eye protection should be worn to prevent injury.*

2.13 Funnel Position

The funnel can be tilted in or out and adjusted closer to or further from the bag opening. Typically, the bottom of the funnel is positioned approximately ½” from the top of the bag opening. The Funnel Bracket Assembly can be pushed inward, closer to the bag dependent upon production dimensions.

NOTE: If the funnel is too close to the front plate, air flow may be blocked causing the bag not to blow open.

CAUTION: *To avoid personal injury, do not operate the T-275 without guards, covers and funnel in the proper position. Funnel should be positioned to prevent an operator from reaching in the seal area. To prevent injury from the seal bar, do not reach under the guard or into the seal area.*

2.14 Cycle Operation Methods

There are four methods to start the seal operation: 1) foot switch operation, 2) guard switch operation, 3) manual button on touch screen and 4) automatic button on touch screen, described as follows:

1. **Foot Switch Operation:** When the foot switch is plugged into the back of the bagger, pressing the foot switch will begin the operation of the sealer mechanism. The guard switch is disabled when the foot switch is plugged in.

NOTE: The touch screen must be toggled to Run. See Chapter 3 for information regarding the touch screen operation.

2. **Guard Switch Operation:** To operate the Seal Mechanism using the Guard Switch, the Foot Switch must be unplugged and a “key” must be inserted into the foot switch plug located at the rear of the unit. When the key is plugged in, the guard switch may be used to cycle the machine. With the key in position, the product is in the bag, and the bag is in the desired seal position, press downward on the front center of the guard to begin the seal operation. The guard is spring-loaded with a microswitch mounted inside the panel.
3. **Manual Cycle Operation:** Read Chapter 3 thoroughly before beginning production.
4. **Automatic Cycle Operation:** Read Chapter 3 thoroughly before beginning production.

2.15 Adjustable Shelf

The T-275 is equipped with an adjustable support shelf which supports heavier products when dropped into the bag. The shelf can be adjusted up and down by loosening both thumb screws and sliding the shelf up and down, ensuring the shelf is level.

2.16 Pull Tension Adjustments

To improve bag alignment, increased web tension may be required. You can increase tension by loosening one of the chucks that hold the roll in position on the shaft and pressing it inwards, toward the center of the roll of bags. Then, tighten while pressing inward. This increases drag on the roll of bags, increasing web tension. Also, if the bags pay off too much when the web advances, increasing drag will prevent bags from paying off excess film.

2.17 Note on Seal Quality

After sealing the first bag and allowing the seal to cool, test the seal for strength by attempting to pull the layers apart. Heat, dwell time, and pressure affect the quality of seals. If the seal separates, increase the seal time. Additionally, check the air pressure and increase the pressure in small increments. After initial startup and after sealing several bags, you may decrease the seal time slightly. Refer to Section 3.6 for Seal Temperature and Seal Time settings.

2.18 Totalizing Counter

To track production, use the Total Counter to count the total number of machine cycles. Press the **Reset** button to reset the counter to zero.

Chapter 3: Touch Screen Operation

Touch Screen Specifications

Touch Screen Program, Overview

Introductory Screen / Technical Assist Screen

Main Menu

Settings Screen

Seal Settings Screen

Options Screen

Job Save Function / Screen

Message Screens / Information Screens

3.1 Touch Screen Specifications

The following are specifications for the touch screen:

Screen	3"
Resolution	128 x 64 pixels
LCD	Green, Red, Orange
Backlight	No Backlight (LED is used)
Memory	384KB
Communication	RS232C
Touch Key Res.	Free, Analog
Languages	
Dimension	110 x 72 x 28mm (W, H, D)
Power	5Vdc, 0.20A
Display	Green, Orange, or Red

3.2 Touch Screen Program, Overview

The Touch Screen Program is a "user-friendly" menu-driven setup and operation program. Pop-up windows are incorporated for quick and easy setting adjustments. Each time a setting is changed, the settings are saved so that if power is lost, the "job" will be recalled automatically without the need for reprogramming.

Three colors may be displayed which indicate the operation status of the bagger, as follows:

Green: Normal Operation

Red: Warning / Stop Mode

Orange: Information / Pause

3.3 Introductory Screen / Technical Assist Screen

When the machine power is turned on, the Technical Assist screen is displayed, with Menu buttons to provide information on the machine. From this screen, contact information for technical assistance, PLC / IO information, and maintenance / troubleshooting information can be accessed. See Figure 3 - 1.



Figure 3 - 1

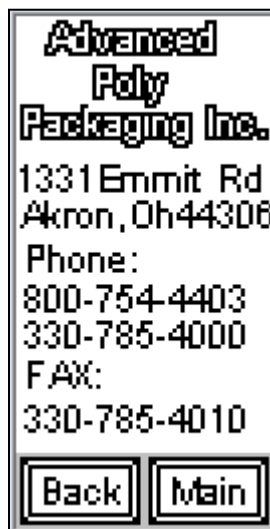

Figure 3 - 2

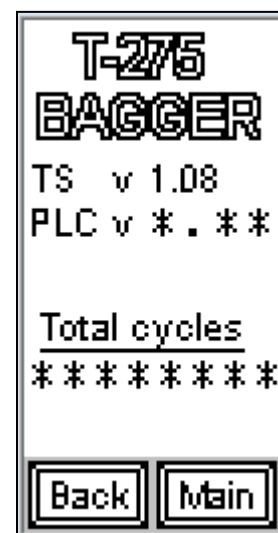

Figure 3 - 3

Press the **Contact Info** button to display the manufacturer's name and contact information. See Figure 3 - 2.

Press the **Maintenance** button to display the Touch Screen (TS) and Programmable Logic Controller (PLC) program versions installed on the machine. The total cycles run on the machine may also be viewed here. See Figure 3 - 3.

Note: When calling Advanced Poly Technical Support, please note this program version. The program version on your machine may be different from

Press the **PLC I/O** button to display inputs and outputs status. From this screen, a maintenance person can troubleshoot the unit by examining the status of inputs and outputs of signals to components on the unit. Typically, this screen is used to provide phone assistance to maintenance personnel. See Figure 3 - 4 through Figure 3 - 7.

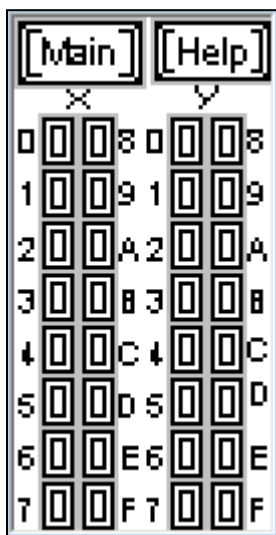

Figure 3 - 4

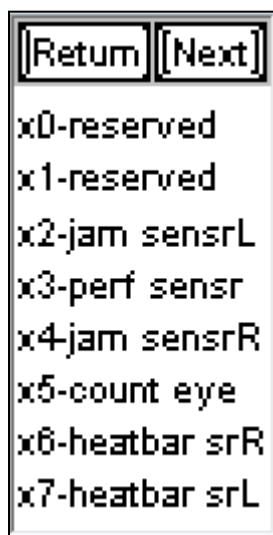

Figure 3 - 5

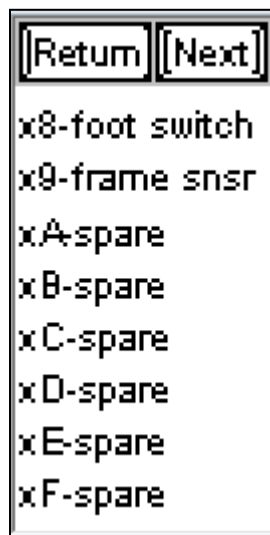

Figure 3 - 6

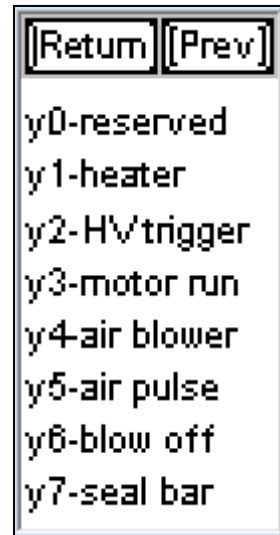

Figure 3 - 7

Press the **Main Menu** button to go to the Main Menu which displays buttons used for the normal operation and settings of the machine. See Section 3.4 Main Menu.

3.4 Main Menu

From the **Main Menu**, all main screens that affect the operation of the machine can be accessed. See Figure 3 - 8.

The top three buttons: WAITING or READY, STOP/START and MANL/AUTO are position at the top of the screen and other operation screens.

WAITING / READY: If the machine is heating or otherwise cannot run, the WAITING message will be displayed. Once the heater bar is with 10% of the set temperature, the READY message will be displayed.

STOP / RUN: The machine must be in the RUN mode to operate. The machine always powers up into the STOP mode and goes to the STOP mode if a Warning message is displayed.

MANL / AUTO: In the MANL (Manual) mode, the footswitch, guard switch or other cycle method must be used to initiate the cycle operation of the machine. In the AUTO mode, the machine will cycle automatically.

SETTINGS menu option displays the settings for Fill Time, Air Pulse and Blow Off timers.

SEAL SETTINGS displays the settings for Seal Time and Seal Point timers and Heater Temp. setting.

OPTIONS menu displays options setup screens for Counters, Compartment Seal, and Counting Funnel options.



Figure 3 - 8

3.5 Settings Screen

From the Settings Screen, several timers that affect the bag cycle operation can be adjusted. See Figure 3 - 9.

Fill Time: In an AUTO mode operation, the Fill Time setting adjust the time during which the operator must load the bag before the seal operation begins. In this “paced operation”, increasing the fill time decreases the cycles per minute, allowing more time for filling.

CAUTION: *To avoid personal injury, do not operate the T-275 in AUTO mode when funnels or guards are removed. Funnels should not be removed unless a light curtain or palm buttons or other approved safety device is installed. Guards should never be removed in an operation status.*

Air Pulse: When the bag stops in the loading position, an air pulse is generated that assists in opening the bag. The Air Pulse setting adjusts the length of time that the air blows from the blow tubes. For larger/wider bags or thicker bags, additional air pulse time may be required. Typically, the set point is .1 to .3 seconds.

Blow Off: To decrease the possibility of bags sticking to the PTFE, a blow off tube is provided as a standard feature. The blower tube is located in the center, immediately below the seal bar. Typically, the blow off time is set to .02 to .15 seconds.

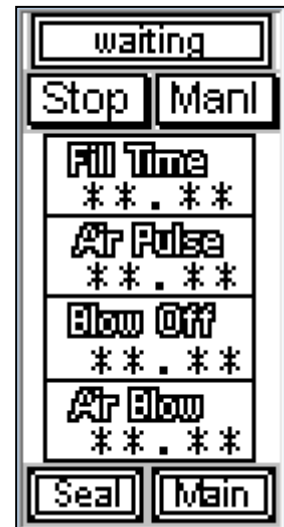

Figure 3 - 9

3.6 Seal Settings Screen

From the Seal Settings Screen, timers and heat adjustments that affect the seal quality can be adjusted. See Figure 3 - 10.

Seal Time: Seal time is the amount of time that the pressure bar is pressed against the heater bar.

Combined with temperature and pressure, seal time is a critical adjustment to obtain good quality seals.

For thicker bags, additional seal time is required. Typically, the Seal Time is set to .2 to .5 seconds, depending on bag thickness.

Seal Point: Adjusting the position that the bag stops in the loading position changes the seal location.

Feeding the bar further out of the machine causes the seal point to increase, closer to the top/opening of the bag. Seal point setting is based upon the bag size and the thickness of the product. Longer bags and thicker product causes the bag to be sealed further down from the top of the bag. Typically, the bag is sealed 1/2" to 2" from the opening. Settings to accomplish this range from .65 to .4.

Figure 3-10

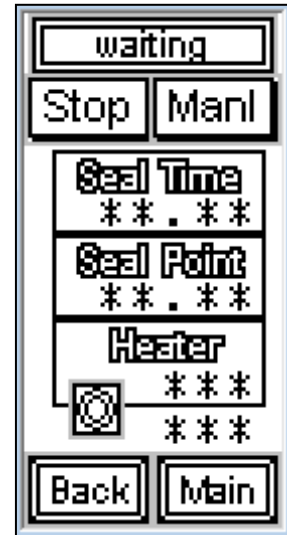

Figure 3 - 10

Seal Temperature (Heater): A Heater Cartridge is mounted inside of a solid heater bar. Temperature is maintained by the controller at a constant temperature but can be adjusted for thicker or thinner bags. Typically, the seal temperature is set between 300 and 400 degrees F. Both the current temperature and the set temperature are displayed. An LED to the left of the setpoint, when lit, indicates that current is being sent to the heater bar.

NOTE: Excessive seal time can cause burns in the PTFE and the bag and decrease the life of the Heater Cartridge.

CAUTION: To avoid injury, do not place fingers in the seal area.

3.7 Options Screen

The T-275 is equipped with several options, but other option can be added to the machine to increase throughput, efficiency, or safety. See Figure 3 - 11.

Counters: The unit is equipped with two internal cycle counters. See Figure 3 - 12.

Totalizing Counter: total cycles of equipment, counts from 0 to 99,999. Reset button zeros this counter.

Preset or Predetermined Counter: counts down from a preset number. When the count reaches zero, the machine operation stops and a message is displayed indicating that the count has been reached. Reset button resets the count to the preset value.

Compartment Seal Option: trapping product in two compartments on the bag. This option is provided for packages whereas one product may damage the other, separating the two products. See Figure 3 - 13. To use this option, toggle the OFF/ON button to ON. Two seal timers are provided to adjust both the first seal and then the second seal. The compartment size of the top compartment may be limited by the amount bag that is fed from the machine before the opening is still inside the machine. Adjust the Main Seal point and Compartment Seal point to adjust the compartment sizes. Several attempts may be required before the optimum setting is achieved.



Figure 3 - 11

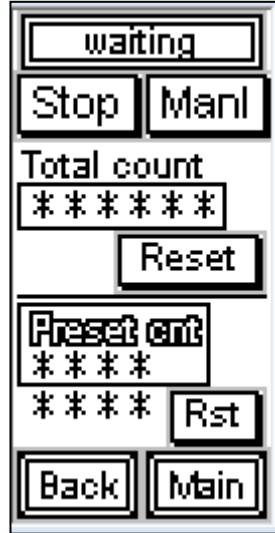

Figure 3 - 12

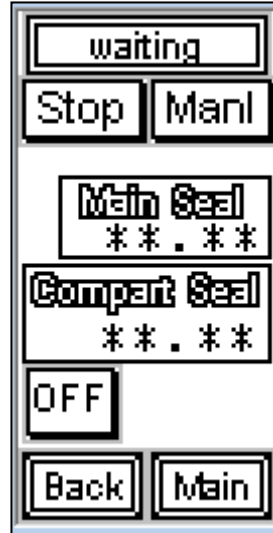

Figure 3 - 13

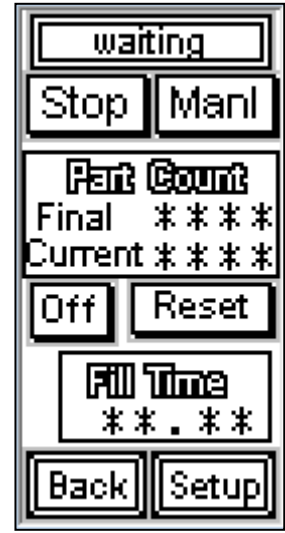

Figure 3 - 14

Counting Funnel Option: Efficiency, production, or accuracy of counts of parts entering the bag. Components, including photo eyes and cables are required. This option also automatically cycles the machine when the part count has been reached. To start using this option, toggle the OFF/ON switch to ON. See Figure 3 - 14.

Fill Time Setting: This timer delays the seal cycle operation after the final count has been reached. If the count is set to one, the Eye Delay setting should be set to a value to allow the product to completely pass through the seal area, to the bottom of the bag, before the seal bar engages. If the seal bar engages before the part is all the way in the bag, possibly sealing on the bag, then increase the Fill Time.

Setup button/Screen: To ensure that one part is only counted as one, a Max Size delay timer is provided. The setup / test screen is provided to assist the operator in determining the amount of time that the product is passing through the eye and then set the Max Size setting to a value that causes the unit to count parts correctly.

To use the Test Screen, first press the reset button. Then, drop one part through the photo eye.

A value will be displayed to the right of number 1 on this screen. If a number is displayed to the right of the 1 and 2, then the part was counted as two. This problem can be corrected by setting the Max Size to a value GREATER than the tested values. See Figure 3 - 15.

The values to the right of the 1 and 2 will automatically reset to zero allowing for continued testing. Continue to drop parts until the MAX value does not increase. Then, set the Max Size to a value greater than the Max displayed value.

Press the Back button to test the Max Size settings to ensure that one product is only counted once.

As a standard feature, the Job Save Screen is provided to save the various “recipes” of settings.

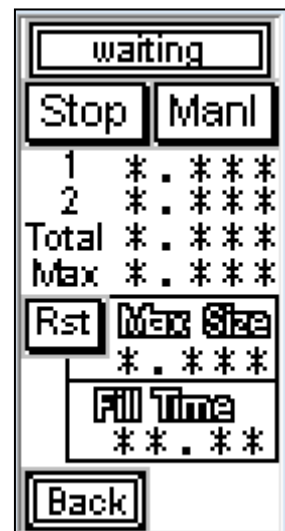

Figure 3 - 15

3.8 Job Save Function / Screen

Sixteen jobs can be saved to include all timer settings and options settings that affect the operation of the machine. See Figure 3 - 16 through Figure 3 - 20.



Figure 3 - 16

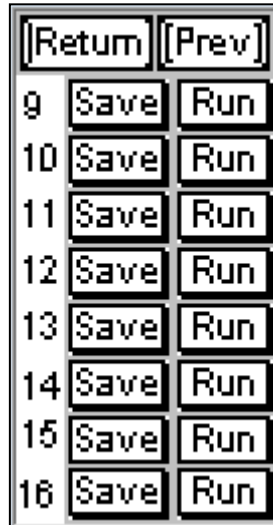

Figure 3 - 17



Figure 3 - 18

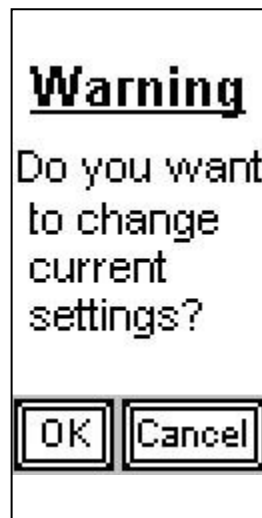

Figure 3 - 19

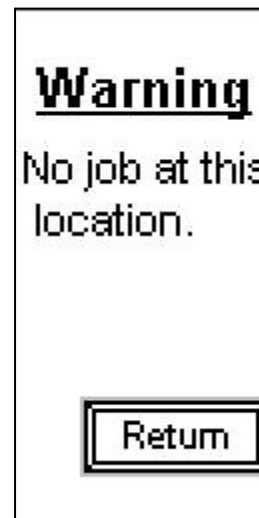

Figure 3 - 20

Once the settings are correct and the machine is functioning properly, press the Save button to the right of the Job Number.

T-275 Job Save Chart

Ensure that you don't overwrite setting of previously saved jobs by using the following chart to write your reference information regarding the job saves.

Job #	Part Number	Description
1		
2		
3		
4		
5		
6		
7		
8		
9		
10		
11		
12		
13		
14		
15		
16		

3.9 Message Screens / Information Screens

Whenever an unusual condition occurs, a Message screen is displayed. If the condition causes the machine to stop the cycle operation, the screen is typically Red. These conditions cause the machine to revert to the Stop condition. For other conditions, an Orange screen is displayed.

Once these messages are cleared, the cycle operation can continue. See Figure 3 - 21 through Figure 3 - 28 for examples of Message / Information screens.



Figure 3 - 21



Figure 3 - 22

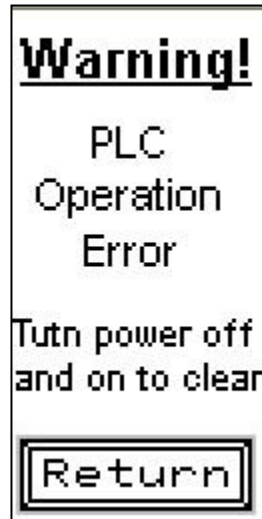

Figure 3 - 23

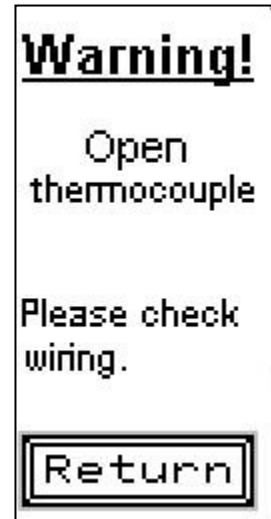

Figure 3 - 24

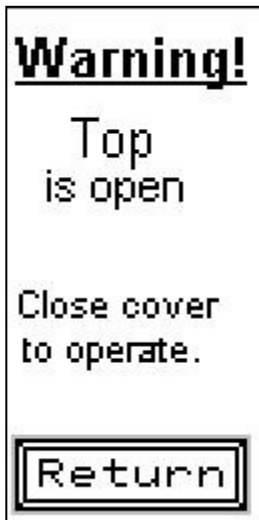

Figure 3 - 25

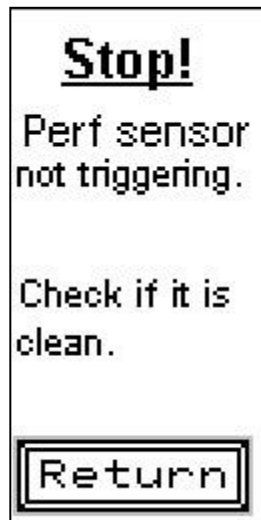

Figure 3 - 26

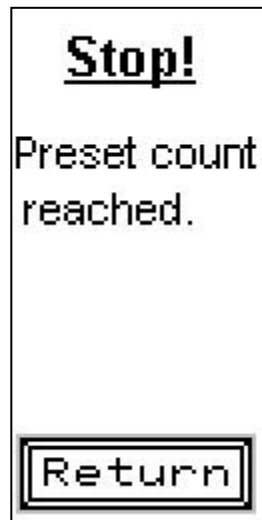

Figure 3 - 27



Figure 3 - 28

This page intentionally left blank

Chapter 4: Adjustments Maintenance, Troubleshooting

Machine Adjustments

Adding PTFE to Rubber Strip and Cleaning

Rubber Strip Replacement

PTFE Spool Advancement

PTFE Sheet Replacement

Heater Cartridge Replacement

Description of Anti-Jam Circuit

Anti-Jam Adjustments / Testing

Preventative Maintenance

Recommended Spare Parts List

Schematics

4.1 Machine Adjustments

Periodically, the T-275 will require readjustments or realignments of components to ensure proper operation. Adjustments may be required after transportation, excessive handling or due to normal wear and tear. The following chapter includes extensive information on how to make these adjustments. “How To” documents for many machine adjustments, replacements or troubleshooting techniques are in the Help Function of our website: www.advancedpoly.com.

CAUTION: Machine adjustments, electrical troubleshooting and component replacement should be performed by qualified maintenance technicians familiar with safety practices including, but not limited to, equipment lock-out / tag-out, voltages and pneumatics. If you are not familiar with the equipment or have not received training on the T-275, consult with APPI Technical Support before attempting adjustments or repairs.

4.2 Adding PTFE to Rubber Strip and Cleaning

New rubber is often sticky when initially used causing bags to cling to the rubber when sealed. But after a short period, the rubber will become slick and not cling to the bag material. Self-adhesive PTFE strips may be added to the rubber pressure strip if the product continually sticks to the rubber strip or to improve seal integrity. Periodically clean the rubber strip with alcohol to remove contaminants and plastic buildup.

4.3 Rubber Strip Replacement

Through normal use, the rubber strip will wear causing seal quality problems. The rubber will also wear prematurely if contacting the product during the seal operation. When the wear affects the seal quality, replace the rubber strip by following these procedures:

1. Remove air from the unit, turn the T-275 power “OFF” and unplug the power cord.
2. Remove the worn rubber pad by pulling from the end corner of the rubber strip. Once started, the rubber will easily slide out from the metal pressure strip housing. See Figure 4-1.
3. Clean out the metal slot with alcohol and a cloth or brush.
4. Slide the extruded rubber into the metal housing slot starting at one end and continuing to work the rubber along the length of the slot. When into position, the rubber strip should be loose in the slot.

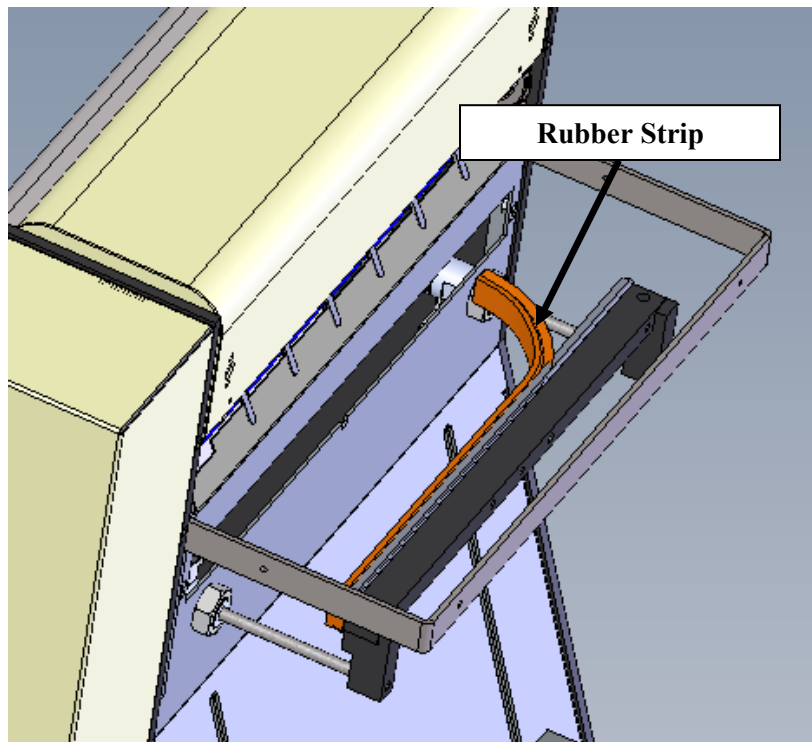

Figure 4-1

CAUTION: Metal housing for rubber strip has sharp corners and sharp edges. When rubber is removed, carefully clean slot with a thick cloth not allowing contact with fingers or hands.

4.4 PTFE Spool Advancement

PTFE will wear with continued use and prematurely tear if contacting the product when sealing. If the PTFE wears or tears affecting the seals, the PTFE can be advanced to bring new material in the seal area. To advance the PTFE, insert a small flathead (common) screwdriver into the bottom 1/4" hole located on the right-side panel of the unit. When you feel the screwdriver enter the slot of the PTFE rod, turn the screwdriver counterclockwise to advance new material into position.

After turning new PTFE into position, turn the rod clockwise slightly so that there is very little tension on the PTFE sheet.

NOTE: If the PTFE is too tight (too much tension), the sheet may tear during the seal operation.

CAUTION: The following maintenance procedures should only be performed by trained and qualified maintenance technicians.

4.5 PTFE Sheet Replacement

When the PTFE sheet has been exhausted, it will become loose from the upper rod and will require replacement. There are three phases when replacing the PTFE:

- Phase 1: Disassembling parts of the machine to gain access to the PTFE Bracket
- Phase 2: Changing the PTFE
- Phase 3: Reassembling the machine parts removed to gain access to the PTFE Bracket.

Refer to Figure 4-2, Figure 4-3, and the Heater Bar Assembly drawing in Section 5.5 with the following instructions. Call APPI (800) 754-4403 and ask for Service if additional help is needed.

Phase 1:

1. Remove air from the unit, turn the T-275 power "OFF" and unplug the power cord.
2. Remove Stainless Steel Cover from back of machine.
3. Lift the funnel assembly and top cover upward.
4. Remove four screws from the guard assembly and remove the Lexan guard, see Figure 4-2.

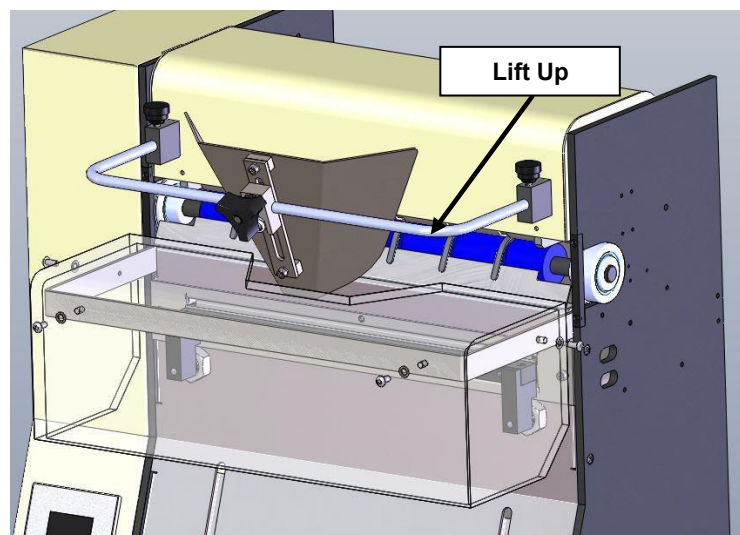

Figure 4-2

5. Allow the sealer mechanism to cool 30 minutes.

for at least

6. Remove the two shoulder bolts from the Pressure Bar (Figure 4-3).

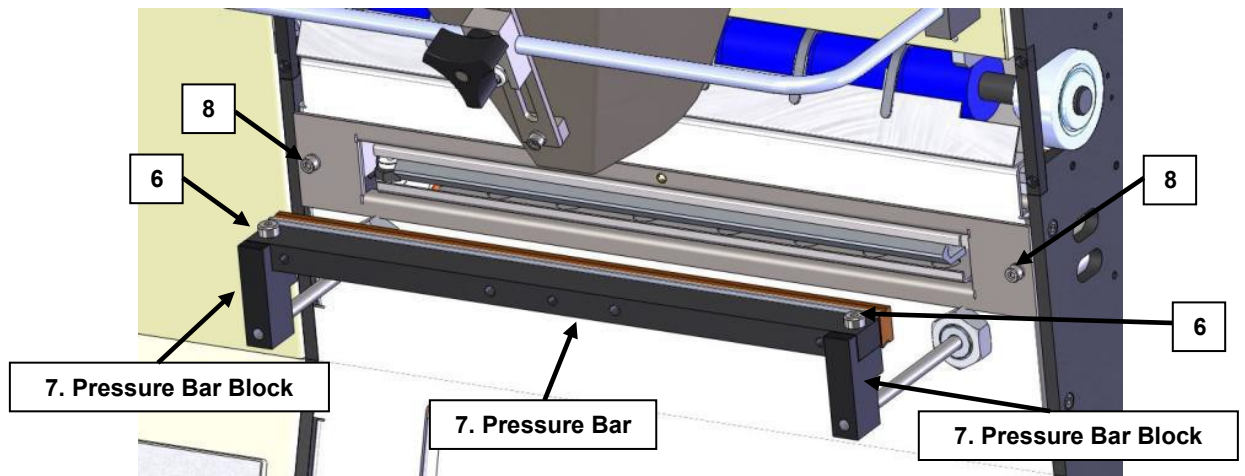

Figure 4-3

7. Remove the Pressure Bar and turn down the black Pressure Bar Blocks (Figure 4-3).
8. Remove the two screws located on the right and left side of the Seal Bar which hold the Seal Assembly mechanism in place (Figure 4-3).
9. From the Back, unplug the left and right side Anti-Jam Sensors, disconnect the Thermocouple, and the left and right Heater Cartridge connectors.
10. From the front, pull one side (right or left side) of the Seal Assembly out from the front plate. Since the Seal Assembly is tight, some maneuvering may be required to remove the assembly from the machine. To avoid damage to components or wiring, do not force the assembly.

Phase 2: (Refer to Section 5.5 Heater Bar Assembly)

1. Remove the two springs holding the shafts together
2. Remove the Socket Head Bolt and Nut on Each side of the Heater Plate.
3. Remove PTFE Shafts and PTFE Sheet.
4. Clean the adhesive from both shafts.
5. Separate the two shafts.
6. Lay one Shaft on the top of the PTFE Sheet and measure from the edge of the PTFE Sheet to the edge of the Shaft. Ensure the PTFE Sheet is in the center of the Shaft.
7. Wrap a piece of tape on the Shaft at the edge of the PTFE.
8. Take the second Shaft, lay the first Shaft next to it and wrap tape around the end of the second Shaft in the same place as the first. Keep the taped ends on the same side of the PTFE Sheet.
9. Remove the adhesive backing from one end of the PTFE Sheet.
10. Align one Shaft parallel to the PTFE Sheet with the taped end of the Shaft meeting up with the edge of the PTFE Sheet. Once the shaft is in position, lower onto adhesive side of the PTFE Sheet.
11. Roll the Shaft until you reach the end of the adhesive part.
12. Repeat with the other Shaft, ensuring the taped ends are on the same side. Once the PTFE Sheet has been rolled over the Shafts, the tape may be removed.
13. Lay Heater Plate on a flat surface so the side plates stick up. Lay PTFE sheet over the Heater Plate so that the shafts are parallel to the plate and the PTFE will roll on the outside of the shaft when reattached.

14. Place the Heater Bar on top of the PTFE sheet so that it fits through the rectangle window through the Heater Plate. The PTFE will be between the Heater Plate and Heater Bar.
15. Replace the 2 socket head bolts and nuts.
16. Replace PTFE Shafts and springs.

Phase 3:

1. Slide Heater Bar Assembly back in.
2. Replace and tighten socket head bolts.
3. Reinstall Pressure Bar.
4. Put a light film of grease on Shoulder Bolts and tighten.
5. Attach Lexan Cover
6. Connect Thermocouple
7. Reconnect right and left Heater Bar Connectors.
8. Reconnect both Heater Bar Sensors
9. Replace Stainless Cover.

CAUTION: When facing the T-275, the motor is on the left side. When reinserting the Heater Bar Assembly use caution not to bump the motor as it will dislocate the Anti-Jam Circuit Board.

4.6 Heater Cartridge Replacement

Since the heater element is a normal wear item, it will require replacement when burned out. Heater element and Heater Bar life span may be increased by timely adjustment of PTFE. If the Heater Bar does not come to temperature fully or does not heat whatsoever, the Heater Cartridge must be replaced. Follow these procedures to replace the element:

1. Remove air from the unit, turn the T-275 power “OFF” and unplug the power cord.
2. Lift the funnel assembly and top cover upward.
3. Remove four screws from the guard assembly and remove the Lexan guard.
4. Allow the Sealer Mechanism to cool for at least 20 minutes.
5. Remove the two screws located on the right and left side of the Seal Bar which hold the Seal Assembly mechanism in place.
6. Pull one side (right or left side) of the Seal Assembly out from the front plate. Since the Seal Assembly is tight, some maneuvering may be required to remove the assembly from the machine. To avoid damage to components or wiring, do not force the assembly.
7. Disconnect the two wire connectors and remove the complete assembly.
8. Wind all the PTFE onto the upper rod and disconnect the PTFE from the lower rod.
9. Unclip the springs from the rods and remove both rods.
10. Loosen the screws that hold the Heater Bar top and Bottom Plate together.
11. Slide the Heater Cartridge from the assembly.
12. If the Heater Cartridge does not break loose, remove the screws entirely and dismantle the Heater Bar.
13. Install the new Heater Cartridge and reassemble the heater bar.
14. Reattach the Heater Bar to the Front Plate Assembly with four screws.

15. Reinstall the PTFE rods and re-thread the PTFE around the spring loaded “U” PTFE shield and reattach the PTFE sheet to the upper rod so that the sheet end is parallel. Wind the PTFE onto the upper rod ensuring that it is evenly and tightly wound.
16. Reattach the springs in the grooves on the rods.
17. Turn the PTFE at least two wraps onto the bottom rod.
18. Reconnect the wire connectors and install the Heater Bar ensuring that the full PTFE rod is positioned.

4.7 Description of Anti-Jam Circuit

The Anti-Jam Mechanism decreases the possibility of damage to the T-275 if product or other objects are in the seal area. The operation of the Anti-Jam circuit should be tested daily prior to production. Although the Anti-Jam unit may also prevent or decrease the opportunity for injuries during the sealing or heating operation, the Anti-Jam is not designed as a safety device. If not adjusted properly, damage may result from obstructions in the seal area or personal injury may result from fingers or hands being in the seal area when sealing.

If properly adjusted, a jam is detected when: 1) the Rubber Pressure Strip does not contact the PTFE at one or both sides of the PTFE shield or 2) the spring-loaded PTFE shield is pressed prior to the Rubber Pressure Strip contacting the PTFE shield. If either of these conditions exist, the Pressure Seal Bar will retract.

4.8 Anti-Jam Adjustments / Testing

The Anti-Jam Mechanism consists of: 1) two (2) cylinder magnetic switches which detects the cylinder position and 2) two (2) photo sensors that detect the spring-loaded PTFE Shield “U” channel position. If the Anti-Jam circuit is not functioning properly, follow these procedures to test and/or adjust the Anti-Jam components:

1. Disconnect the Air Supply from the machine, located on the panel just above the power cord.
2. Remove the Stainless Back Cover by removing the Screw on each side.
3. Go to the **Main Menu** and press **Tech Assist**, then press **PLC I/O**.
4. On the front of the T-275, push the Pressure Bar in until it just touches the front plate.
5. On the PLC I/O Screen, X2 and X4 should be illuminated. If they are, continue to step 7. If not, follow the next instructions.
6. One at a time, loosen the switch on each of the air cylinders and move it forward and backward until X2 or X4 turn on. Adjust each side so both X2 and X4 are on, then tighten. See Figure 4-4 for Left Air Cylinder and Figure 4-5 for Right Air Cylinder.

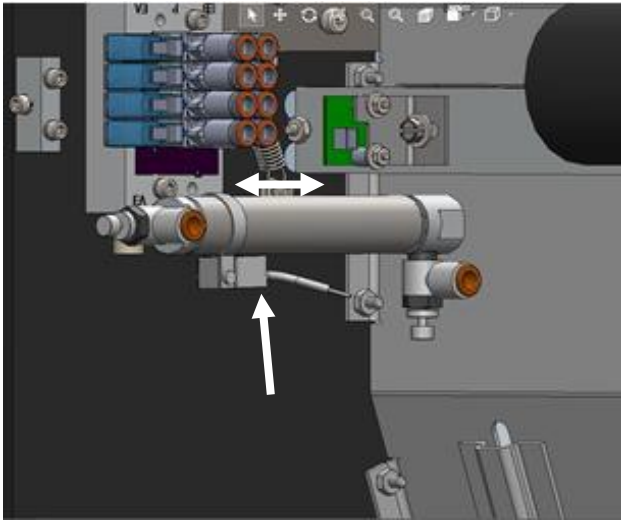

Figure 4-4

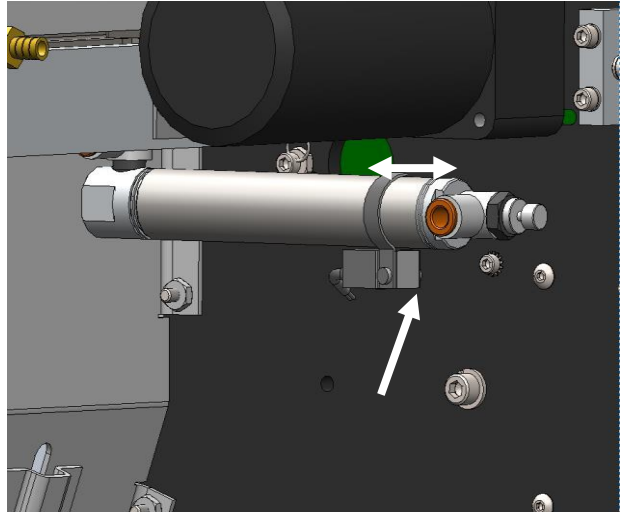

Figure 4-5

7. Now push the Pressure Bar all the way in, see Figure 4-6. The X6 and X7 LEDs should be illuminated on the PLC I/O screen. If one or both lights do not illuminate, test each side individually by following these next steps.



Figure 4-6



Figure 4-7

8. Release the Pressure Bar and apply pressure to only the left side of the heater bar, (Figure 4-7). Pressing it in all the way in, X6 should illuminate. Release and repeat to the Right side, X7 should illuminate.
9. If one side does not turn on, you may have a bad connector, a bad Anti-Jam Circuit Board, or the Sensor may need to be adjusted. To check the Actuator Sensor and determine which of these issues you need to address, locate the Anti-Jam Circuit Boards and “Pig Tail” Connectors (TP-T8ME0161-1) on the back side of the T-275. See Figure 4-8 and Figure 4-9.

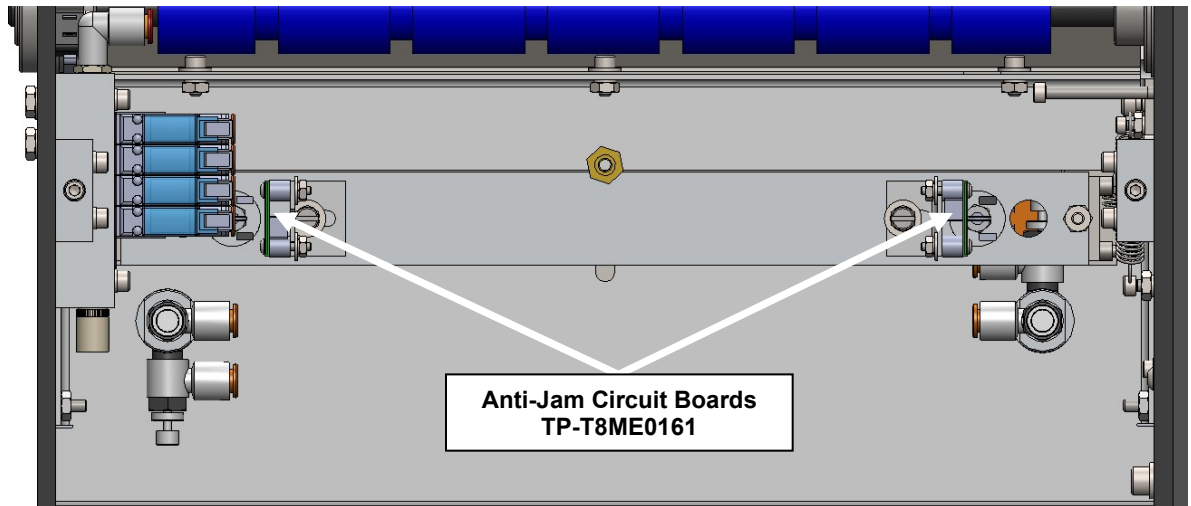

Figure 4-8

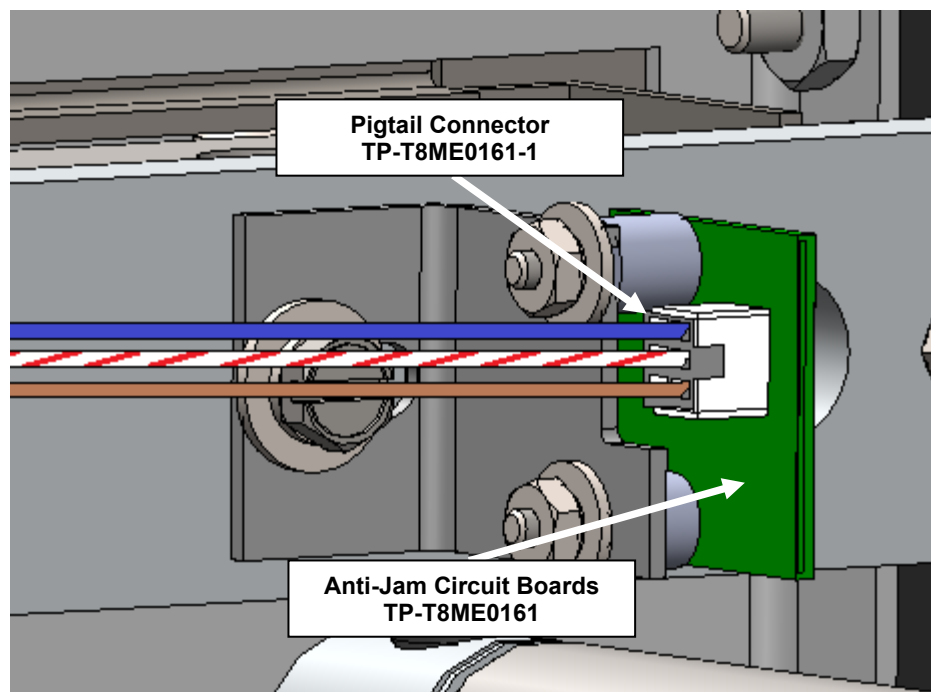

Figure 4-9

10. To check the Sensors and the Actuator on the Anti-Jam Circuit Board (as shown in Figure 4-10), place a small Screw driver between the two Sensors (Figure 4-11), breaking the beam that is projected, causing X6 (left side) or X7 (right side) to illuminate on the PLC I/O screen.

If X6 or X7 does turn on when placing the Screw Driver between the Sensors, you need to adjust the Anti-Jam Circuit Board (Step 11). If the LEDs still do not illuminate, continue to step 13.

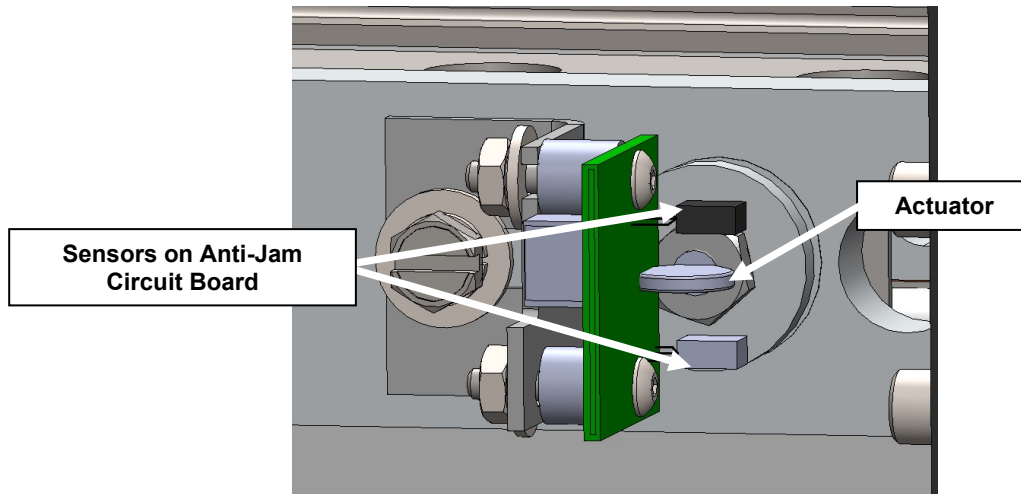

Figure 4-10

11. While one person pushes in the Pressure Bar all the way, the other person will loosen the two Lock Nuts holding the Circuit Board to the Anti-Jam Mounting Bracket, see Figure 4-12.

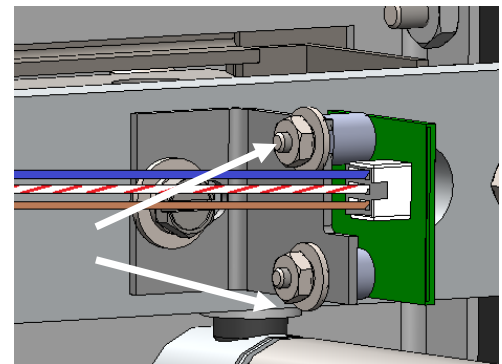

Figure 4-11

12. While one person continues to hold the Pressure Bar all the way in, the other person will move the Anti-Jam Circuit Board back and forth (Figure 4-13) until X6 or X7 turns on. Tighten the two Lock Nuts holding Circuit Board to the Bracket. If X6 or X7 did not turn on while doing this procedure, go to the next step.

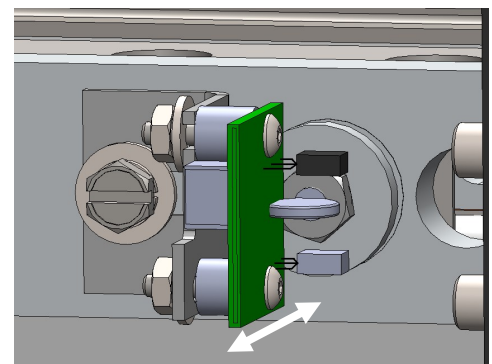

Figure 4-12

13. Unplug both Pigtail Connectors, plug the Right Pigtail into the Left Anti Jam Circuit Board and plug the Left Pigtail into the Right Anti-Jam Circuit Board.
14. Reconnect the air supply to the bagger, turn power on. Now cycle the bagger. Did the Heater Bar Sensor Error go to the other side? If it did then your Pigtail is malfunctioning. Call Advanced Poly for a new Anti-Jam Pigtail, part number TP-T8ME0161-1. If the Error did not change sides, then you need a new Anti-Jam Circuit Board, part number TP-T8ME0161.

If you need further help, please call the Service Department at Advanced Poly Packaging, (800) 754-4403.

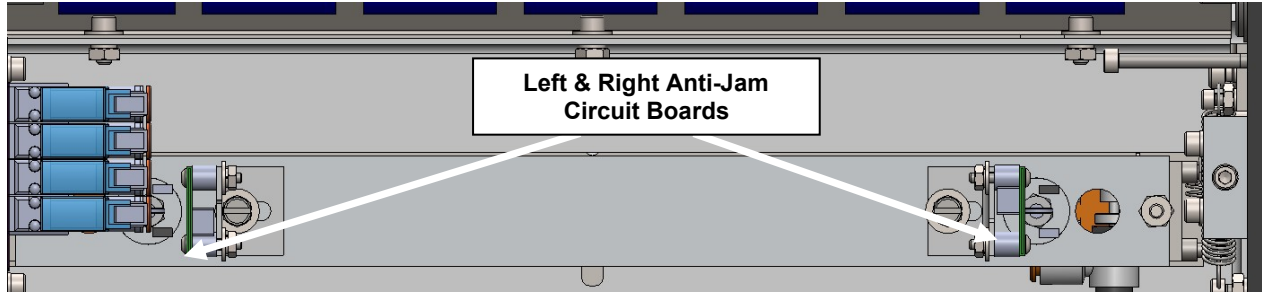

Figure 4-13

4.9 Preventative Maintenance

The following maintenance items should be performed by the operator or maintenance personnel to prolong the life of the equipment. Failure to perform these tasks may result in premature wear, personal injury, or equipment damage.

Item	Description	Frequency
Anti-jam	Test Anti-Jam prior to production	Daily
Pressure	Check air pressure to ensure 60-70 PSI	Daily
PTFE	Inspect for wear / holes, turn 1/4" if required	Daily
Rollers	Clean with Isopropyl Alcohol	Daily
Perf Sensor	Clean with Isopropyl Alcohol	Daily
Rubber Strip	Clean rubber strip with Isopropyl Alcohol	Weekly
Pressure Bar	Remove air and push in manually to ensure free movement with no binding	Weekly
Springs	Inspect for cracks in springs, ensure free movement	Monthly
Wiring	Ensure no loose contacts or worn shielding	Monthly
Fasteners	Tighten mounting bolts and fasteners	Monthly
Blower filter	Clean/replace if air flow decreases	Monthly
Electronics	Remove covers and blow out compartments	Monthly

4.10 Recommended Spare Parts List

The following spare parts are recommended for your inventory which include components which can easily be replaced. These items are either wear items or other components which may fail during the day-to-day operation of the machine.

TO-T12-SP10 T-275 Spare Parts Kit (Level 1)

Part Number	Description	Qty
TP-T8MA00140	Seal Bar Rubber Strip	1
TP-T8MA00130	PTFE Sheet	2
TP-207026	Fuse, 8 Amps / 250V	1
TP-217117	Heater Cartridge (400W)	1
TP-221416	Thermocouple Wire	1
TP-404628	1/4" blue tubing	5
TP-406181	4 Micron Filter	1
TP-112300	Rubber Feet	4
TP-402255	Valve	1
TP-108156	Ext. Spring, Teflon Rods	2
TP-403148	Cylinder, NCM Round Body	1
TP-503102	Belt, Brake (Synchronous Belt)	1
TP-402255	Valve, 5 Port Solenoid w/ 1/4"	1
TP-108153	Extension Spring, .36"x.037" MW	2
TP-T8ME0161	Anti-Jam Sensor Board	1
TP-T8ME0161-1	Pigtail for Anti-Jam Sensor	1
TA-T14-00124-1	Tabletop Perf Sensor, High Voltage	1
TP-106141	Cotter Pin, 1/16 x 3/4	1
TP-108118	Torsion Spring: .025Wire .1890	1
TP-T1MC00124-1	High Voltage Sensor	1
TP-T1MC00124-3	Mount, High Voltage Sensor	1
TP-215022	Switch, Snap-Action, General P	1
TP-108099	Compression Spring, Guide Roll	2
TP-108156	Extension Springs, Teflon Rods	2

4.11 Schematics

Electrical and Pneumatic drawings are provided along with descriptions to assist in troubleshooting the T-275.

110V Circuit

Circuit drawings are provided to assist in troubleshooting the functionality of the T-275.
See Dwg T274Elec-0.

Thermocouple Expansion Card, Heater Circuit

A circuit diagram of the Thermocouple Expansion controller TC4 with correct Dip switch settings is provided. See Dwg T1kST-E56_TC4.

Pneumatic Diagram

Diagrams of the pneumatic components and connections are provided to assist in troubleshooting the functionality of the T-275.
See Dwg T3-00164 Rev A.

T-275 Electrical Schematic

T275Elec-0

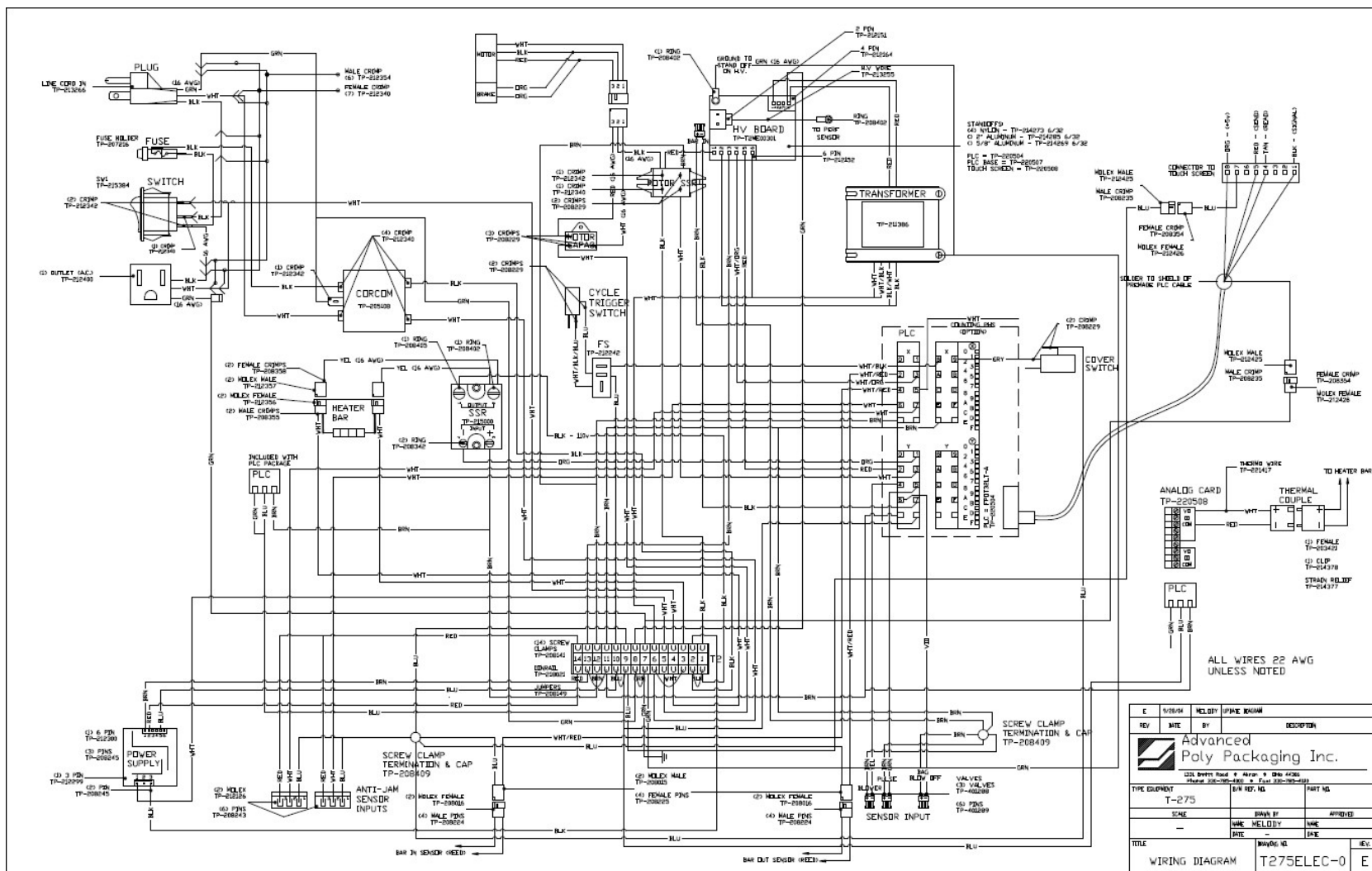

Analog Card, Temperature Controller, Heater Circuit

T1kST-E56_TC4

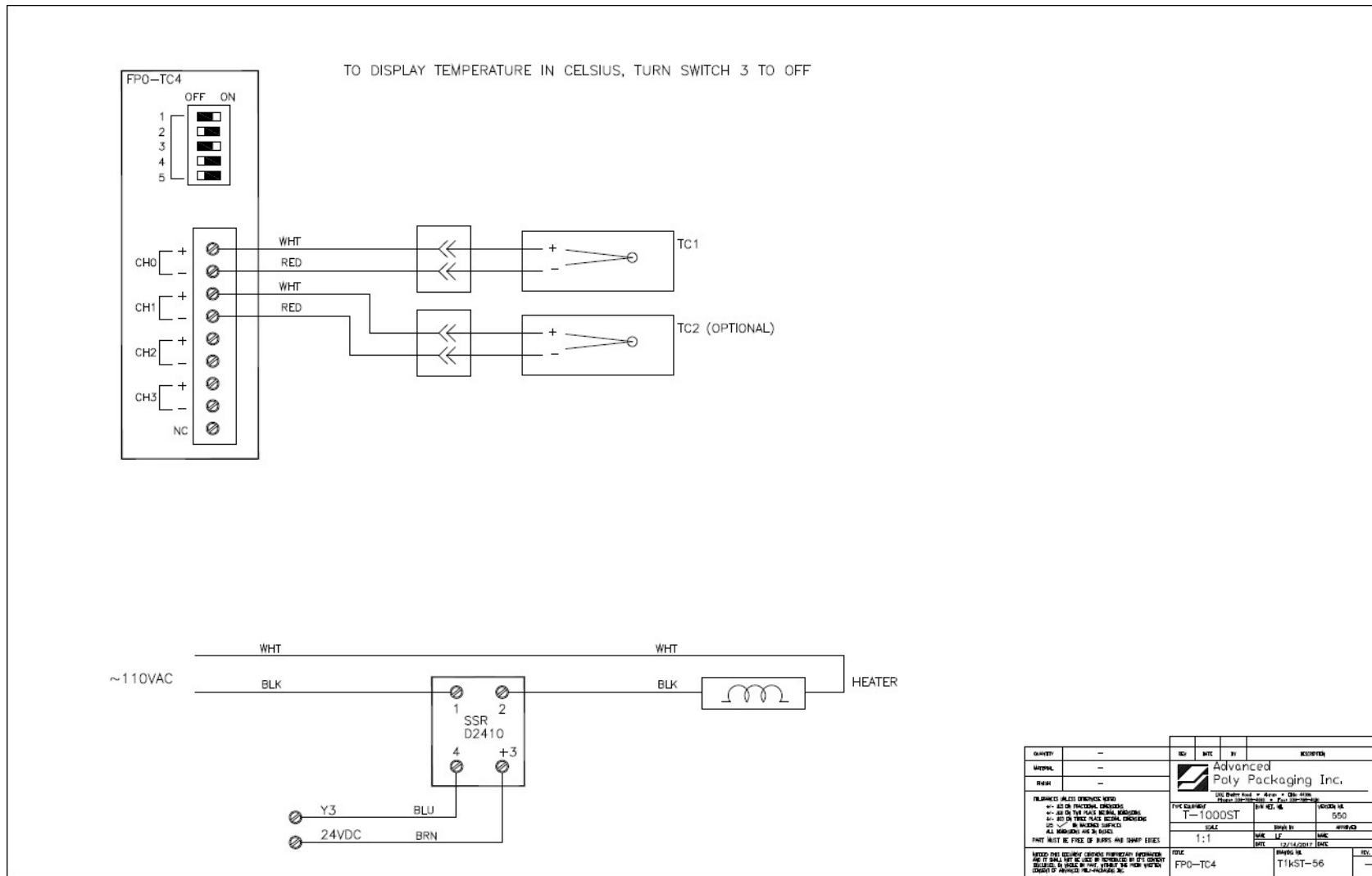

QUANTITY	-	REV	BY	REVISION
INTERNAL	-	Advanced Poly Packaging Inc.		
MARK	-	POLY PACKAGING INC.		
<small> TOLERANCES UNLESS OTHERWISE NOTED: +- AS ON FRACTIONAL DIMENSIONS +- AS ON THE FULL DECIMAL DIMENSIONS AS SHOWN ON THE DRAWING ALL DIMENSIONS ARE IN INCHES PART MUST BE FREE OF BURRS AND SWAMP EDGES </small>		USE ONLY THIS DRAWING FOR THE PART SHOWN T-1000ST SCALE: 1:1 DATE: 12/14/2017	DRAWN BY: 550 CHECKED BY: 550 DATE: 12/14/2017	
<small> VERIFY THIS DRAWING CAREFULLY FOR ANY DISCREPANCIES AND IF ANY ARE FOUND, NOTIFY THE DESIGN ENGINEER IMMEDIATELY. THIS DRAWING IS THE PROPERTY OF POLY PACKAGING INC. </small>		TITLE: FP0-TC4 PART NO.: T1kST-56 REV: -		

T-275 Pneumatic System Layout Diagram

T3-00164 Rev A

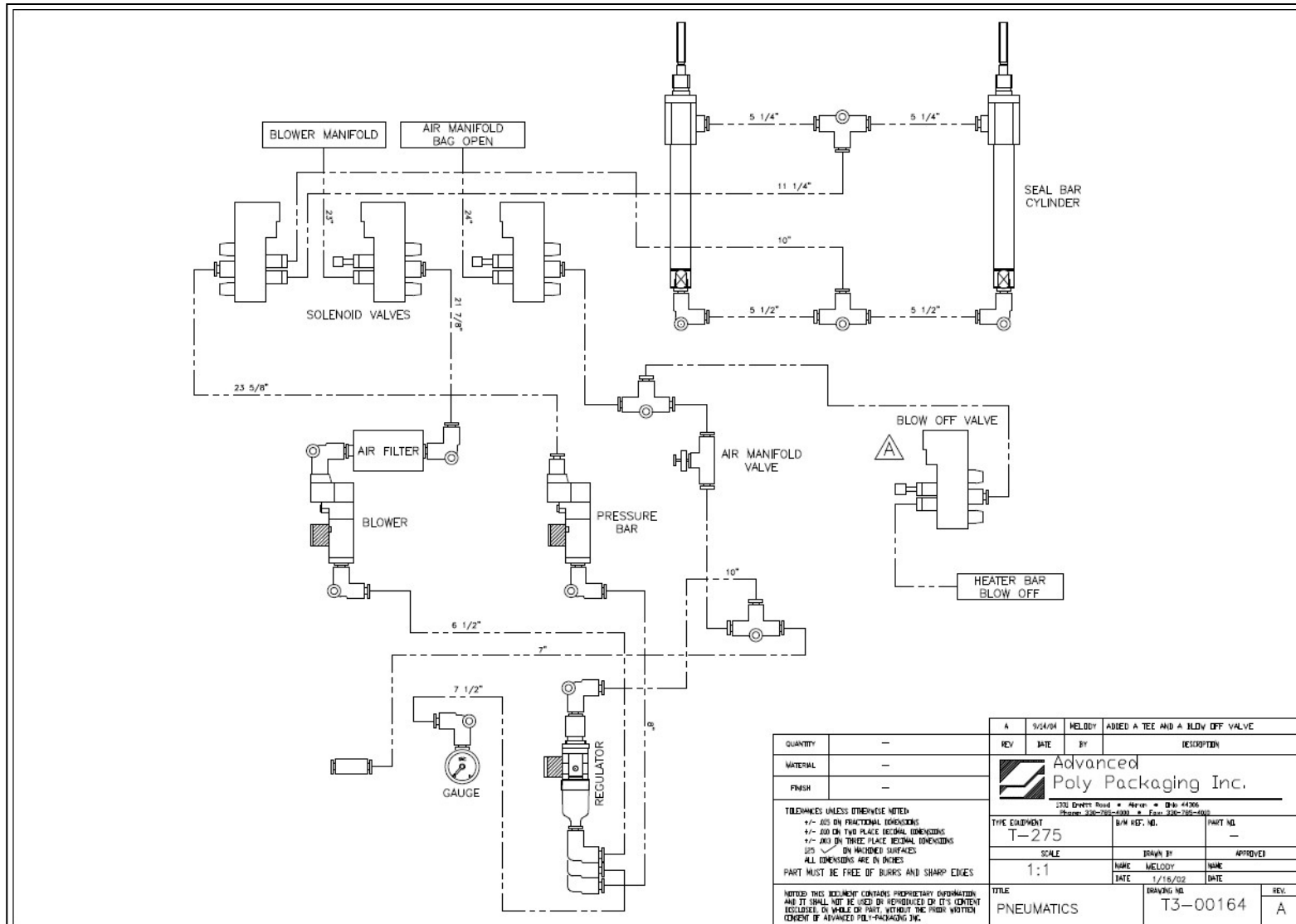

QUANTITY	—	REV	DATE	BY	DESCRIPTION
MATERIAL	—	 1370 Dwight Road • Akron • OH 44306 Phone: 330-782-1000 • Fax: 330-782-1000			
FINISH	—				
TOLERANCES UNLESS OTHERWISE NOTED: +/- .005 ON FRACTIONAL DIMENSIONS +/- .003 ON TWO PLACE DECIMAL DIMENSIONS +/- .003 ON THREE PLACE DECIMAL DIMENSIONS .015 ON MACHINED SURFACES ALL DIMENSIONS ARE IN INCHES PART MUST BE FREE OF BURRS AND SHARP EDGES		TYPE EQUIPMENT T-275		B/W REF. NO. PART NO.	
NOTICE THIS DOCUMENT CONTAINS PROPRIETARY INFORMATION AND IT SHALL NOT BE USED OR REPRODUCED OR ITS CONTENT DISCLOSED IN WHOLE OR PART, WITHOUT THE WRITTEN CONSENT OF ADVANCED POLY-PACKAGING INC.		SCALE 1:1		DRAWN BY NAME: MELODY DATE: 1/16/02	
		TITLE PNEUMATICS		NAME: MELODY DATE: 1/16/02	
		DRAWING NO. T3-00164		PART NO. —	
				APPROVER NAME: MELODY DATE: 1/16/02	
				REV. A	

Chapter 5: Parts and Drawings

Parts Component Identification

T-T275 Tabletop Bagger System Layout

Electronics Assembly

Mechanical Assembly

Heater Bar Assembly

Notes

5.1 Parts Component Identification

This section includes assembly drawings of the T-275. Please use APPI part numbers whenever possible to order replacement parts. You can also refer to Drawing Numbers and Corresponding Item Numbers on the drawings to assist in determining the required components.

5.2 T-T275 Tabletop Bagger System Layout

ITEM NO.	QTY.	PART NO.	DESCRIPTION
1	1	TA-T7-1000	ELECTRONICS ASSEMBLY
2	1	TA-T8-2000	HEATER BAR ASSEMBLY
3	1	TA-T7-4000	MECHANICAL ASSEMBLY
4	1	TA-T8-9000	FUNNEL ASSEMBLY

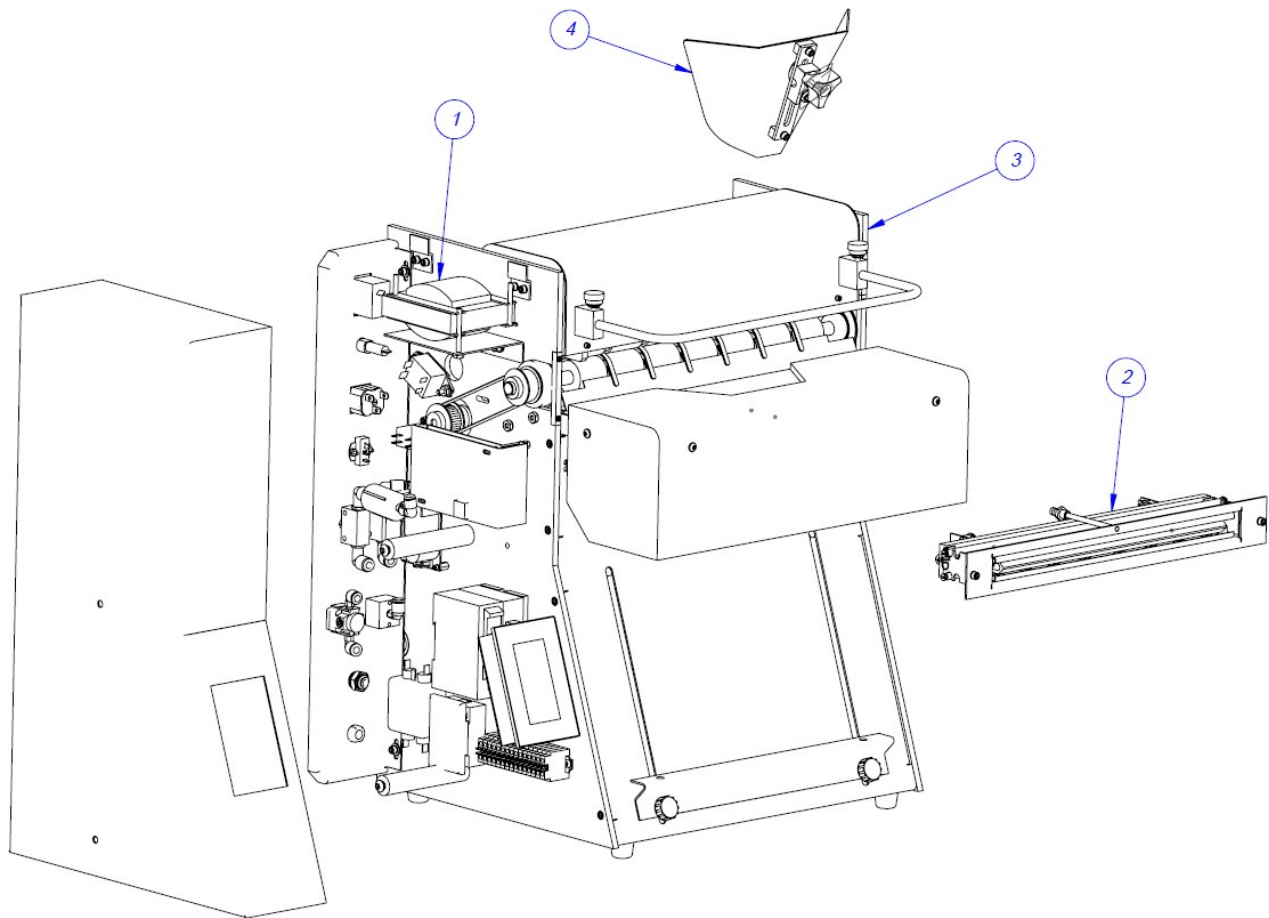

5.3 Electronics Assembly

TA-T7-1000

ITEM NO.	QTY.	PART NO	DESCRIPTION
1	1	TP-205108	EMI FILTER, CORCOM
2	1	TP-207216	FUSE HOLDER
3	1	TP-215384	POWER SWITCH, NO LONGER USED
4	1	TP-215000	SOLID STATE RELAY
5	1	TP-215000A	COVER
6	1	TP-212410	AC OUTLET
7	1	TP-T8MA00191	MOUNTING BRACKET, TRANSFORMER
8	1	TP-218021	DIN RAIL
9	15	TP- 208142	LARGE TERMINAL BLOCK
10	1	TP-212243-1	FOOT SWITCH JUMPER PLUG
11	1	TP- 213361	24VDC, 3AMP POWER SUPPLY
12	4	TP-214268	STAND-OFF .38"
13	1	TP-T1ME00301	HIGH VOLTAGE BOARD
14	1	TP-220504	PLC, FPO-E32T-A EXPANSION I/O
15	1	TP-220507-1	PLC BASE
16	1	TP-220508	PLC ANALOG MODULE
17	2	TP-214278	STEEL 3/8 MALE/FEMALE 6-32
18	1	TP-215003	SOLID STATE RELAY
19	1	TP-112240	POWER CORD STRAIN RELIEF
20	1	TP-211386	TRANSFORMER
21	2	TP- 214285	STAND-OFF 1-1/2" LONG 6-32
22	1	TP-212242	3-PIN SOCKET W/ BRACKET
23	1	TP-208143	FIXED BRIDGE

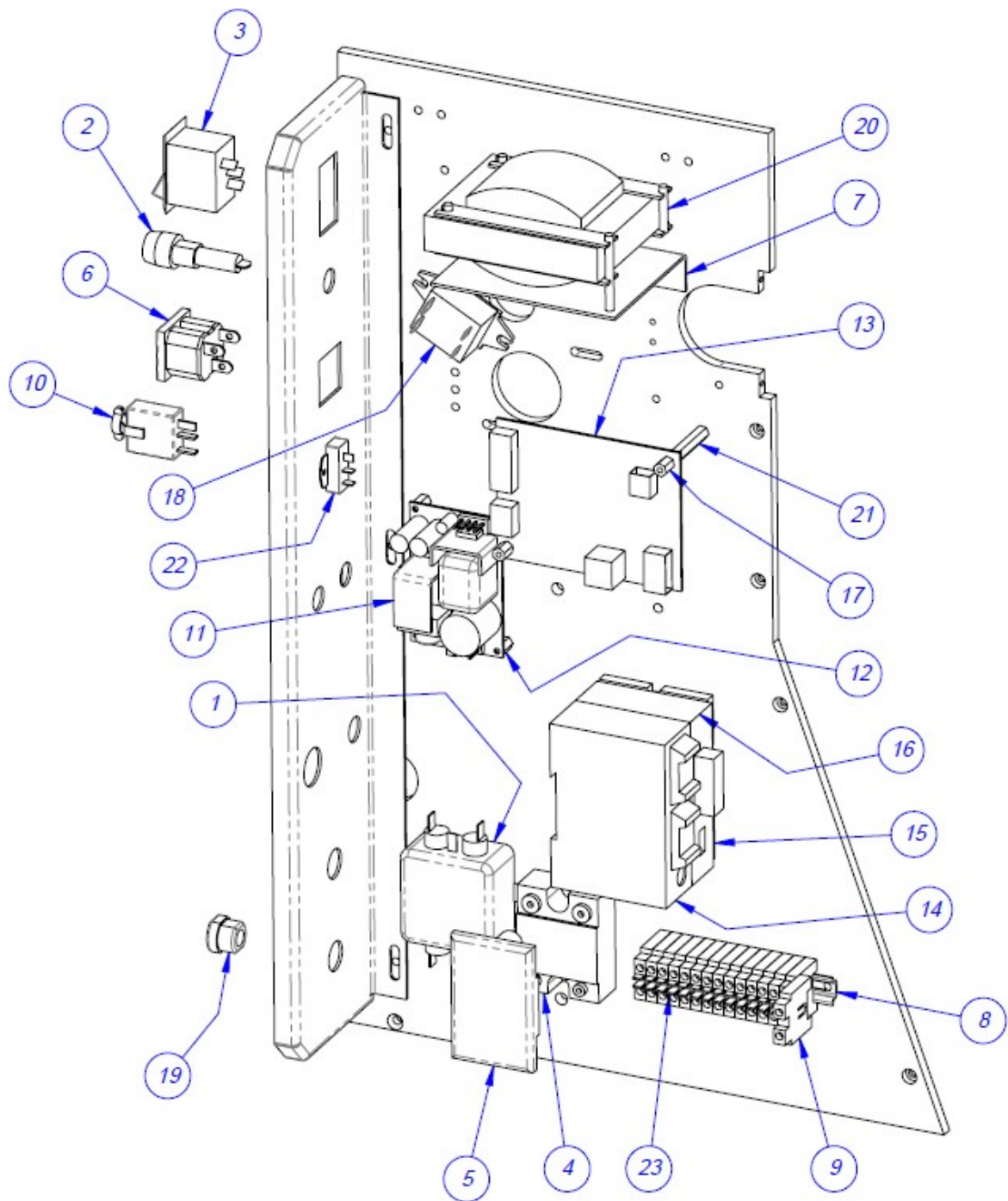

5.4 Mechanical Assembly

PN: TA-T7-4000

ITEM NO.	QTY.	PART NO	DESCRIPTION
1	1	TP-T8MA00103	ELECTRONICS PANEL
2	2	TP-T8MA00108	COVER HANGER
3	1	TP-T8MA00109	RUBBER STRIP HOLDER
4	1	TP-T8MA00110	PRESSURE BAR HOLDER
5	1	TP-T8MA00111	BACK PANEL TEMPLATE
6	1	TP-T8MA00115	STANDOFF
7	2	TP-T8MA00118	SEALER BLOCK
8	1	TP-T8MA00126	LOAD SHELF
9	1	TP-T8MA00127	BAG ROLL SHAFT
10	1	TP-T8MA00128	GUARD MOUNT
11	1	TP-T8MA00129	LEXAN GUARD
12	2	TP-T8MA00131	COVER MOUNT
13	1	TP-T8MA00132	ROLLER STOP
14	1	TP-T14M1008	SHAFT STEEL BACK UP
15	1	TP-T8MA00139	REGULATOR MOUNT
16	1	TP-T8MA00140	RUBBER STRIP
17	1	TP-T8MA00174	LEFT SIDE PLATE
18	1	TP-T8MA00175	RIGHT SIDE PLATE
19	2	TP-T8MA00176	BEARING KEEPER
20	1	TP-T8MA00177	FRONT PLATE
21	1	TP-T8MA00178	EXIT PLATE
22	1	TP-T8MA00179	FINGER PLATE
23	1	TP-T8MA00180	BLOWER HOUSING
24	1	TP-T8MA00182	STEEL BACK-UP ROLL
25	1	TP-T8MA00183	RUBBER DRIVEN ROLLER
26	1	TP-T8MA00184	COVER
27	1	TP-T8MA00185	TIMING PULLEY
28	1	TP-T8MA00186	LOWER BRACE
29	1	TP-T9MA00187	MOUNTING PLATE
30	1	TP-T8MA00191	MOUNTING BRACKET, TRANSFORMER
31	1	TP-T8MA00192	SIDE COVER
32	1	TP-T8MA00194	TIMING PULLEY

PN: TA-T7-T1000

33	1	TP-T8MA00201	PIVOT SHAFT
34	2	TP-T8MA00204	LATCH BODY
35	2	TP-T8MA00205	SIDE PLATE, BACKUP ROLL
36	1	TP-T8MA00207	CROSS BRACE
37	1	TP-T8MA00208	AIR PULSE TUBE MANIFOLD
38	1	TP-T8MA00209	HIGH VOLT COVER BRACKET
39	2	TP-T1MA00049	FILM TENSION HUB
40	1	TP-T1MC00083	INSULATOR (HIGH VOLTAGE SENSOR)
41	1	TP-T1MC00124-1	HIGH VOLTAGE TANG
42	1	TP-T1MC00124-3	HIGH VOLTAGE SENSOR MOUNT
43	1	TP-106214	COTTER PIN
44	1	TP-108118	TORSION SPRING
45	2	TP-107340	THRUST BEARING
46	2	TP-107341	SLEEVE BEARING
47	2	TP-107342	THRUST BEARING.
48	2	TP-504107	1/2" I.D. BEARING
49	1	TP-501162	UNWIND MOTOR
50	1	TP-405268	AIR KNIFE VENTURI
51	1	TP-405268-2	AIR KNIFE
52	1	TP-405268-3	AIR KNIFE
53	2	TP-215022	LIMIT SWITCH, Snap Action
54	2	TP-504114	BEARING
55	2	TP-109152	KNOB
56	2	TP-109212	1/4-20 x 1.00" THREADED KNOB
57	1	TP-220356	TOUCH SCREEN
58	2	TP-402107	FLOW CONTROL VALVE
59	1	TP-406012	THREADED GAUGE
60	1	TP-406258	MINI REGULATOR
61	1	TP-106126	SPRING PIN
62	2	TP-108220	SPRING PLUNGER
63	2	TP-109213	THREADED KNOB
64	4	TP-112300	RUBBER TAPERED BUMPER
65	4	TP-401134	HEX PLUG
66	1	TP-401253	BULKHEAD CONNECTOR
67	1	TP-401222	QUICK CONNECT NIPPLE
68	1	TP-402252	5-STATION MANIFOLD

69	4	TP-402255	VALVE
70	5	TP-401257	ELBOW, 1/4" TUBE x 1/8 NPT
71	2	TP-404262	MUFFLER
72	1	TP-503102	BRAKE BELT
73	2	TP-403148	AIR CYLINDER
74	2	TP-T8MA00138	ROD MOUNTS
75	1	TP-501162	MOTOR CAP
76	1	TP-406181	AIR FLOW FILTER
77	1	TP-401291	1/4" x 1/4" ELBOW
78	2	TP-108156	SPRING
79	3	TP-401277	ELBOW, 1/4" TUBE x #10-32
80	1	TP-208400	RING TERMINAL
81	2	TP-214273	STAND-OFF, NYLON, 1/2", #4-40
82	1	TP-208342	WIRE TERMINAL
83	4	TP-101092	1/4-20 NUT WITH TOOTH LOCK WASHER
84	1	TP-401258	STRAIGHT CONNECTION, 1/4" TUBE x 1/8"NPT
85	1	TP-401292	STRAIGHT CONNECTOR, 1/4" TUBE x 1/4 NPT

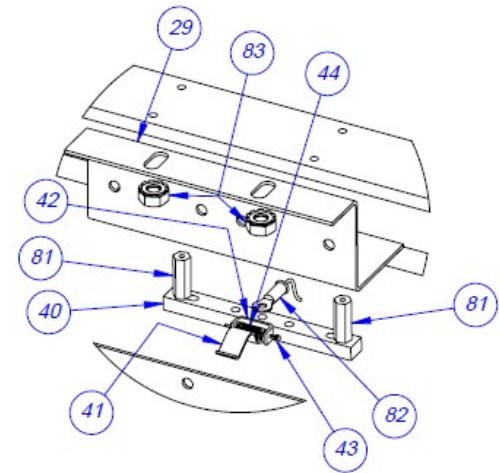
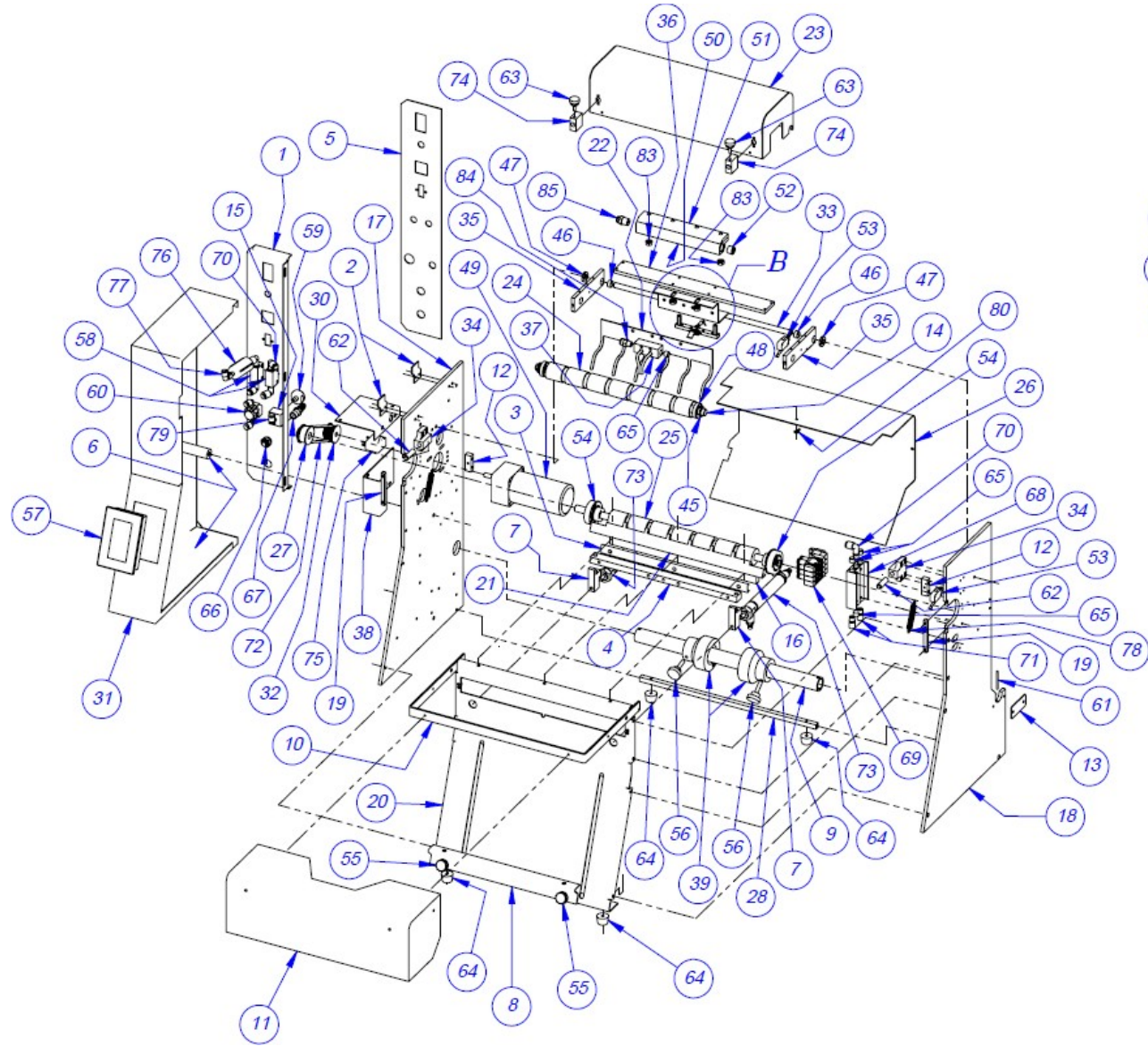

DETAIL B
SCALE 1 : 2

5.5 Heater Bar Assembly

PN: TA-T82000

ITEM NO.	QTY.	PART NO	DESCRIPTION
1	1	TP-T8MA00121-5	HEATER PLATE & BRACKET SUBASSEMBLY
2	1	TP-T8MA00112-1	BRACE
3	2	TP-T8MA00226	PHOTO EYE BRACKET
4	1	TP-T8MA00199	ANTI-JAM
5	1	TP-T8MA00202	HEATER BAR
6	2	TP-T8ME0161	ANTI-JAM SENSOR BOARD ASSY
7	2	TP-T8MA00227	HEATER BAR SLIDE
8	2	TP-109210	THUMB SCREW
9	4	TP-104135	STANDOFF, NYLON SPACER
10	2	TP-T8MA00124	PTFE SHAFT
11	2	TP-101103	SAE NUTS
12	2	TP-T8MA00231	ROUND UNIT SPACER
13	2	TP-108099	COMPRESSION SPRING
14	2	TP-108153	EXTENSION SPRING
15	1	TP-T8MA00225	BLOW OFF TUBE
16	1	TP-221416	THERMOCOUPLE WIRE

