

T-200™ Advanced Poly Table Top Bagger/Sealer

Operation Guide, Version 3 - TM-T8-MANV3
Setup, Operation and Parts Manual

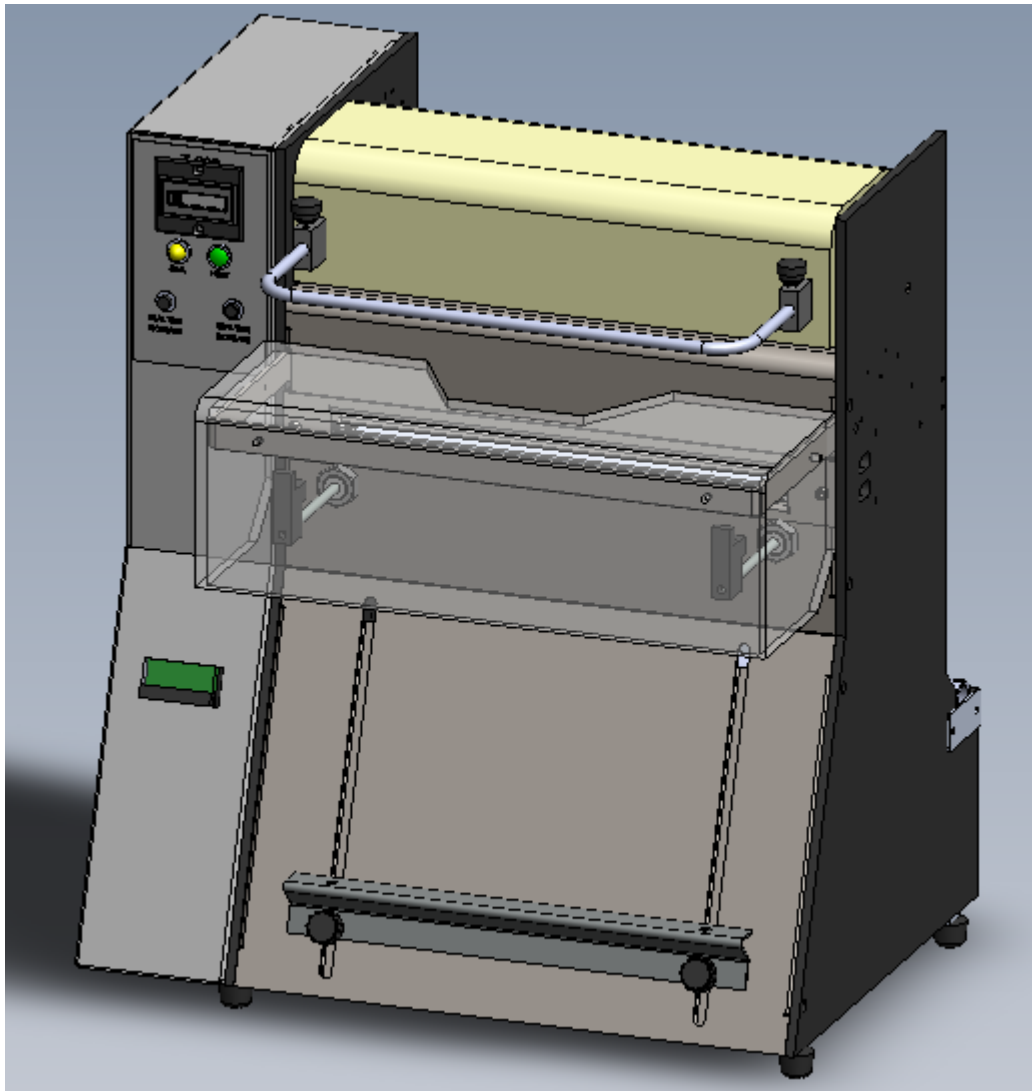

 Advanced
Poly-Packaging, Inc.

1331 Emmitt Road • Akron, OH 44306 • 1-800-754-4403 • fax 330-785-4010 • www.advancedpoly.com

Acknowledgments

Written By: Annie Braddock

Reviewed By: Stuart Baker

Copyright

2015 (Ver. 3), ©Copyright 2/2000 Advanced Poly-Packaging, Inc. (APPI). All rights reserved.

This manual and the program operating the equipment described in it are copyrighted. You may not copy this manual in whole or part without the consent of Advanced Poly-Packaging, Inc.

All information pertaining to the promotion, sale, distribution, operation and maintenance of the T-200™ Advanced Poly Tabletop Bagger / Sealer including this manual, drawings, schematic, wiring diagrams, videos, brochures, specification sheets, figures, charts, or any other information, due to its proprietary design and manufacture remain the property of Advanced Poly Packaging, Inc. Unauthorized duplication, distribution or disclosure to third parties without the express permission of Advanced Poly-Packaging, Inc. is strictly prohibited.

Trademarks

T-200™ Table Top Bagger/Sealer is a trademark of Advanced Poly-Packaging, Inc. Advanced Poly-Packaging, Inc. owns also the following trademarks: Advanced Poly-Bags, Advanced Poly-Bagger, Seal-a-Print, Roll-a-Print, Twin-Seal, Advanced Poly-Pack, Advanced Poly-Bag, Advanced Bag.

Limited Warranty and Disclaimer

Warranty period is 12 months or 1,000,000 cycles whichever comes first. The warranty commences on the date of delivery of the equipment to the Purchaser. APPI warrants to the Purchaser that the equipment is free from defects in workmanship or material under normal use and service. During the warranty period, APPI agrees to repair or replace, at its sole option, without charge to Purchaser, any defective component part of the equipment. To obtain service, Purchaser must return the equipment or component to APPI or an authorized APPI distributor or service representative in an adequate container for shipping. Any shipping charges, insurance, or other fees must be paid by Purchaser and all risk for the equipment shall remain with Purchaser until such time as APPI takes receipt of the equipment. Upon receipt, APPI, the authorized distributor or service representative will promptly repair or replace the defective component and then return the equipment or component to Purchaser, shipping charges, insurance and additional fees prepaid. APPI may use reconditioned or like new parts or units, at its sole option, when repairing any component or equipment. Repaired products shall carry the same amount of outstanding warranty as from original purchase. Any claim under the warranty must include a dated proof of delivery. In any event, APPI's liability for defective components or equipment is limited to repairing or replacing the components. This warranty is contingent upon proper use of the equipment by Purchaser and does not cover: expendable component part such as thermocouple wire, heater cartridge, rollers, bushings, and the like; or if damage is due to accident, unusual physical, electrical or electromechanical stress, neglect, misuse, failure of electric power, water damage (from airlines), improper environmental conditions, transportation, tampering with or altering of the equipment, packaging of corrosive or contaminating products or other products damaging to components, and equipment or components not owned or in the possession of original Purchaser. APPI will not be liable for loss of production, profits, lost savings, special, incidental, consequential, indirect or other similar damages arising from breach of warranty, breach of contract, negligence, or their legal action even if APPI or its agent has been advised of the possibility of such damages or for any claim brought against the Purchaser by another party. This warranty allocates risks of equipment failure between Purchaser and APPI. APPI's pricing reflects this allocation of risk and the limitations of liability contained in this warranty. The warranty set forth above is in lieu of all other express warranties, whether oral or written. The agents, employees, distributors and dealers of APPI are not authorized to make modifications to this warranty, or additional warranties binding on APPI. Accordingly, additional statements such as dealer advertising or presentations, whether oral or written, do not constitute warranties by APPI and should not be relied upon. Warranty on equipment is considered void when outstanding balances become delinquent (over 30 days late - 60 days after ship date). Equipment Integration to other Equipment: APPI assumes no responsibility for the integration of its products to other products or within a system unless APPI performs the integration, testing and provides the results of the tests to the purchaser in writing. Furthermore, APPI assumes no responsibility for bag sizing whether suggested or recommended.

TABLE OF CONTENTS

Chapter 1: Getting Started	4
1.1 Welcome.....	5
1.2 Overview	5
1.3 Contact Information	5
1.4 Using This Manual	5
1.5 Special Features of the T-200.....	6
1.6 Available Options.....	6
1.7 Special Note on Safety	6
1.8 Specifications	7
1.9 Unpacking & Setup	7
1.10 Operating Environment	7
1.11 Warranty Registration	8
Chapter 2: Getting Started & Equipment Operation	10
2.1 Air & Power Hookup	11
2.2 Roll Mounting and Threading	11
2.3 Main Power	11
2.4 Operation / Component Test Prior to Production.....	11
2.5 Heat / Dwell Time Adjustment	11
2.6 Air / Seal Pressure Adjustments.....	12
2.7 Blower / Bag Opening.....	12
2.8 Funnel Position.....	12
2.9 Sealing the Bag / Foot Switch or Guard Switch Operation.....	12
2.10 Adjustable Shelf	13
2.11 Pull Tension Adjustments	13
2.12 Note on Seal Quality	13
2.13 Bag Counter / Counter Reset.....	13
Chapter 3: Operation Adjustments / Replacement of Wear Items	16
3.1 Adding PTFE Anti-Stick Material to Rubber Strip and Cleaning	17
3.2 Rubber Strip Replacement	17
3.3 PTFE Anti-Stick Sheet Advancement.....	18
3.4 PTFE Anti-Stick Sheet Replacement	18

3.5 Heater Cartridge / Thermocouple Replacement.....	20
3.6 Description of Anti-jam Circuit	20
3.7 Anti-jam Adjustments / Testing	20
3.8 Preventative Maintenance	21
Chapter 4: Parts Identification	22
<hr/>	
4.1 Recommended Spare Parts List	23
4.2 Parts / Component Identification.....	23
4.3 Pneumatic Diagram	23
4.4 Wiring Diagram.....	23
A. T-200 System Layout.....	24
B. T-200 Electronics Assembly	25
C. T-200 Heater Bar Assembly.....	27
D. T-200 Main Frame Assembly	29
E. T-200 Adjustable Chute Assembly	32
F. T-200 Pneumatic Layout.....	33
G. T-200 Electrical Layout	34

Chapter 1: Getting Started

Welcome

Overview

Contact Information

Using This Manual

Special Features of the T-200

Available Options

Special Note on Safety

Specifications

Unpacking & Setup

Operating Environment

Warranty Registration

1.1 Welcome

Thank you for selecting the T-200™ Series Table Top Bagger / Sealer. The T-200 is easy to operate and quick to set up, making it ideal for long or short packaging runs. When labor reduction and fast changeover are important, the Advanced Poly T-200™ Tabletop Bagger / Sealer provides a reliable bagging solution by using pre-opened bags on rolls, manufactured by Advanced Poly-Packaging, Inc.

1.2 Overview

The T-200 is designed to package various industrial, medical, molded and food products. With bag sizes that range from 2" x 3" to 11" x 16" and mil thickness from 1 mil to 4 mil, the T-200 will demonstrate to be a versatile bagger.

The T-200 is designed to lower your packaging costs with increased speeds, versatility, reliability, and simplicity. Instead of sealing with a conventional jaw sealer, which requires the operator to pull bags out and open them individually from a carton, the T-200™ Tabletop Bagger / Sealer removes this hassle by feeding pre-opened bags through the bagger, allowing the operator to easily index the bag into position. Once loaded, the bag can be sealed without having to separate the bag at the perforation. Ideal for numerous short runs with virtually no production loss for job changeovers since all that is required is a roll change. Single knob heat, dwell and cool setting adjustments makes setups a snap.

1.3 Contact Information

To better serve your bagging needs, call **(330) 785-4000** or toll free **1-(800) 754-4403** for convenient service solutions, Monday through Thursday, 9:00 AM to 5:30 PM EST, or Friday 9:00 AM to 5:00 PM EST. For technical assistance with current machinery, ask for **Service**. To order spare parts for your system, ask for **Parts**. To order auxiliary equipment for your current system, ask for **Machine Sales**. To place an order for bags, ask for **Bag Sales**.

You may also contact any of these departments by email:

Reach Service at Service@advancedpoly.com

Reach Parts at Parts@advancedpoly.com

Reach Machine Sales at MachineSales@advancedpoly.com

Reach Bag Sales at Bagsales@advancedpoly.com

For general inquiries: Sales@advancedpoly.com

Or visit us online at www.advancedpoly.com

In order to provide the best service possible, please have model and serial number ready.

1.4 Using This Manual

The following manual conventions are frequently used to assist in understanding important information, alerting the operator of potentially dangerous or damaging practices, and the normal functions of the T-200 Sealer / Bagger.

Text normal text

Italics Used for emphasis

BOLDFACE Used to identify heading names

Note: Used to identify important information

CAUTION: Warning messages. To avoid physical harm, damage to equipment or damage to the product. Be sure to read these messages carefully.

1.5 Special Features of the T-200

The T-200 has been designed with simplicity of operation and ease of maintenance in mind.

The totalizing counter counts cycles of operation and has a reset feature. Press the reset button at the beginning of each shift or day to record packaging production.

Patented design seal assembly - PTFE Anti-Stick material is only in contact with hot wire during sealing and is then stripped away from the wire immediately after sealing; reduces contamination buildup, increases Material life and improves seal integrity.

Double or triple seal quickly and easily - Seal the bag a second time or third time by pulling down and sealing for consistent placement of seals.

Patented Anti-Jam Device - During the loading and sealing operation, this device detects obstructions and automatically reverses the pressure bar, discontinuing the cycle operation.

1.6 Available Options

Spare Parts Kit: Additional Anti-Stick material, heater wire, valve and other components make this kit a must.

See Chapter 4, Section 4.1 for recommended Spare Parts Kit.

Special funnels: Send us your product and we will evaluate the loading to determine the best funnel design.

Bag deflator: Quickly mounts to the sealer bar squeezing the air from the bag while sealing.

1.7 Special Note on Safety

Many safety features have been included in the mechanical, electronic and pneumatic systems of this machine. Despite these safety precautions, operators may receive lacerations, minor burns, or crushed or broken bone injuries if they come in contact with any moving components. Improper use, improper adjustment and neglect of preventative maintenance may result in serious personal injury. No special personal protective equipment is required to operate the equipment, but eye protection, gloves or other protection should be worn, depending on the characteristics of the product being packaged and the method of loading the product.

Please carefully read the following precautions to operate the equipment properly and avoid injury:

General topics regarding safety:

- **CAUTION:** *Never operate the machine with covers, guards or funnels removed*
- **CAUTION:** *Do not reach under the Lexan guard or into the seal area.*
- **CAUTION:** *Only certified maintenance or electrical personnel should perform maintenance procedures.*
- **CAUTION:** *Standard tag/lockout procedures include disconnecting air and electricity when performing maintenance tasks.*

- **CAUTION: Do not attempt to reprogram machine.**
- **CAUTION: Use only APPI approved parts/replacement components.**
- **CAUTION: Do not modify or otherwise alter machine operation, components or design.**

Potential injuries:

- **CAUTION: Cuts or minor abrasions from sharp objects, including not but limited to sheet metal fingers, screws, edges**
- **CAUTION: Crush injuries from pinch points, including but not limited to bag rolls shaft, pinch rollers, funnel assembly or seal area.**
- **CAUTION: Back, arm, leg or other muscle strain from lifting rolls of bags, boxes of bags or product.**
- **CAUTION: Muscle strain from loading bags, separating bags or other repetitive functions**
- **CAUTION: Electrical shock if unit is not turned off and unplugged prior to removing guards or covers**
- **CAUTION: Minor burns form exposure to heater bar**
- **CAUTION: Eye injury from not wearing eye protection during loading of product or sealing of bags.**

1.8 Specifications

Dimensions:	19.25” wide x 14.675” deep x 21” tall
Weight:	50 lbs.
Air:	50 psi
Electric:	115V/60Hz or 220V/50Hz
Bag sizes:	2 x 2 up to 11 x 16
Product pass through area:	approx. 2.75”

1.9 Unpacking & Setup

The T-200 is shipped completely assembled and in a carton. Remove all tape, banding or packing materials that secure the machine. To ensure the highest production possible, consider product flow to the bagger and packaged product flow away from the bagger when positioning the bagger into your packaging areas.

1.10 Operating Environment

When you choose a location for installation, make sure the area is free of excess dust, dirt and moisture. Operating room temperature should range from 50°F to 100°F (10°C to 37.77°C).

1.11 Warranty Registration

This section must be completed and returned to Advanced Poly Packaging, Inc. to register the T-200 for Warranty Protection.

T-200 Serial Number:

(Serial number located on the back panel)

Company Name and Address

Contact Name(s) / Title(s) / Phone Number

<hr/> <hr/> <hr/>	<hr/> <hr/> <hr/>
-------------------	-------------------

Please fax or mail this page to:

Service Manager
Advanced Poly-Packaging, Inc.
1331 Emmitt Road
Akron, OH 44306
USA

Fax # (USA) 330-785-4010

Or email the information above to: service@advancedpoly.com

This page intentionally left blank.

Chapter 2: Getting Started & Equipment Operation

Air & Power Hookup

Roll Mounting and Threading

Main Power

Operation / Component Test Prior to Production

Heat / Dwell Time Adjustment

Air / Seal Pressure Adjustments

Blower / Bag Opening

Funnel Position

Sealing the Bag / Foot Switch or Guard Switch Operation

Adjustable Shelf

Pull Tension Adjustments

Note on Seal Quality

Bag Counter / Counter Reset

2.1 Air & Power Hookup

The T-200 is equipped with an internal regulator and the air supply should be fed to the T-200 with ¼” min. O.D. poly tubing. Make the connection at the rear of the sealer. Set the air pressure on the T-200 between 40 and 50 psi.

2.2 Roll Mounting and Threading

Loosen one of the knobs located on the chuck which secures the roll into position. Mount the roll of bags onto the bag roll shaft and secure the bag roll into position with the chuck. With the loose web of bags falling over the rear of the roll, insert the web into the slot above the stainless rear cover and below the top cover. With the web of bags positioned under the top cover, raise the top cover of the T-200 by lifting the funnel mounting rods. Pull the web forward through the cover while lowering the top cover. When the top cover is lowered, the first bag should open by the airflow. The roll shaft is fixed into position with a pin and will not spin. The roll spins on the fixed shaft. See Threading Diagram at the end of the chapter, Figure 2-1.

2.3 Main Power

The power switch is located on the rear right lower side. In the ON or “up” position, the switch is illuminated indicating that power is supplied to the unit.

2.4 Operation / Component Test Prior to Production

Prior to beginning production, the anti-jam mechanism should be tested by following these procedures:

Test 1: With air applied and the power on, position an object over 1/4” in thickness (a pen or pencil for example) on the far left side of the seal bar with the object in contact with the PTFE Anti-Stick Sheet, but not pressing in the spring-loaded “U” channel. Press the footswitch. The Anti-jam circuit is working properly if the pressure bar retracts and immediately releases. If the pressure bar does not immediately retract, do not begin production and refer to Chapter 3, Section 3.6 for description of Anti-jam circuit.

Test 2: With air applied and the power on, position an object over 1/4” in thickness (a pen or pencil for example) on the far left side of the seal bar with the object pushing inward on the PTFE Anti-Stick Sheet. Ensure that you are pressing in the spring-loaded “U” channel Anti-Stick Shield and then press the footswitch. The Anti-jam circuit is working properly if the pressure bar does NOT move inward. If the pressure moves inward, do not begin production and refer to Chapter 3, Section 3.6 for instruction on Anti-jam Adjustments.

Continue these test procedures with the object being moved along the entire seal area length from the left to the right side of the seal area.

2.5 Heat / Dwell Time Adjustment

The T-200 uses a heater cartridge to supply constant heat to the heater bar. The temperature controller maintains the set sealing temperature after a minimal initial phase when the T-200 is first powered on and the temperature will climb and then settle into the set temperature.

The duration of time that the sealer bar is against the plate can be adjusted using the two buttons marked Seal Time and Cool Time. Tapping the Seal Time button will increase the amount of time used to create the seal while tapping the Cool Time button will decrease the amount of time used to create the seal.

Note: If the sealer bar touches the front of the machine, and immediately reverses, this is an Anti-Jam condition. Something is obstructing the sealing area, the main air pressure is too low, or the Anti-Jam sensors need adjusted.

Note: Excessive seal time can cause burns in the PTFE Anti-Stick sheet and the bag and decrease the life of the heater bar.

CAUTION: THE SEAL BAR IS HOT! DO NOT PLACE FINGERS IN THE SEALING AREA.

2.6 Air / Seal Pressure Adjustments

To obtain good consistent seals, air pressure must be adjusted. The pressure valve is located on the rear of the unit. Typically, the air pressure is set to a constant pressure of 40 to 50 psi. To increase the pressure, pull the black knob outward, away from the machine and then turn clockwise; then push the knob inward to lock into position. To decrease pressure, pull the knob outward, turn clockwise and press the knob inward.

2.7 Blower / Bag Opening

The T-200 Sealer/Bagger is equipped with a 6" wide air knife and flow control valve to ensure that the bags blow open quickly and consistently. Since the air knife speeds up air, compressed air is conserved. Adjust the volume of air with the Blower flow control valve located on the rear of the unit (bronze knob). To slow or reduce the volume of air, turn the knob counterclockwise; to increase the air flow, turn the knob clockwise. Begin by turning the blower all the way down and increase slightly until the bags blow open continuously and consistently. Once adjusted, there is a locking nut to prohibit the knob from loosening.

Note: Excessive air flow can cause the bag to move around and product to possibly spill from the bag.

2.8 Funnel Position

The funnel can be tilted in or out and adjusted closer or further from the bag opening. Typically, the bottom of the funnel is positioned approximately ½" from top of the bag opening. The funnel bracket assembly can be pushed inward, closer to the bag dependent upon production dimensions.

Note: If the funnel is too close to the front plate, air flow may be blocked causing the bag not to blow open.

CAUTION: To avoid personal injury, do not operate the T-200 without guards, covers and funnel in position.

2.9 Sealing the Bag / Foot Switch or Guard Switch Operation

Carefully pull the bag downward into the sealing position and load the product by allowing the product to slide down the funnel.

Once the product is in the bag, the bag can be sealed or left unsealed.

To start the seal operation of the bagger, the operator has two options: 1) footswitch operation or 2) guard switch operation, described as follows:

1) Foot switch operation: when the footswitch is plugged into the back of the bagger, pressing the footswitch will begin the operation of the sealer mechanism. The guard switch is disabled when the footswitch is plugged in.

2) Guard Switch operation: to operate the seal mechanism using the guard switch, the footswitch must be unplugged and a “key” must be inserted into the footswitch plug located at the rear of the unit. When the key is plugged in, the guard switch may be used to cycle the machine. With the key in position and the product is in the bag and the bag is in the desired seal position, press downward on the front center of the guard to begin the seal operation. The guard is spring-loaded with a micro switch mounted inside the panel (See Fig. 2-9).

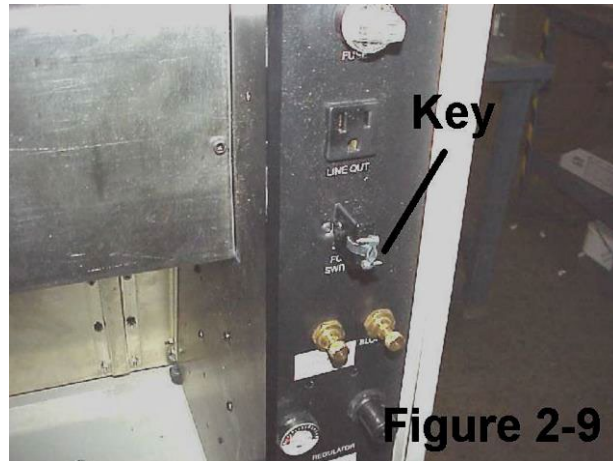

CAUTION: *Ensure your fingers are not in the seal area when pressing the footswitch or guard switch or your fingers may be pinched or burned by the closing seal bar. Once the bag is sealed, pull downward until the next empty bag is in the seal position, load the bag and continue the seal process.*

2.10 Adjustable Shelf

The T-200 bagger is equipped with an adjustable support shelf which has two functions: 1) assists the operator with seal position by allowing the operator to pull the bottom of the bag down to the shelf, 2) Supports heavier products when dropped into the bag. The shelf can be adjusted up and down by loosening both thumb screws and sliding the shelf up and down, ensuring the shelf is level.

2.11 Pull Tension Adjustments

Since perforation strength is determined by bag width and thickness, pull tension adjustments may be required to avoid bags separating or prematurely tearing at the perforation.

If the bag perforation tears prematurely while pulling the bag downward into the seal position, adjust the tension of the film by 1) sliding one or more of the rubber grommets which are located on the front roller in the top cover left or right, out of contact with the bag 2) loosening the roll chucks that contact the bag roll core plugs.

If the roll unwinds or excess slack is in the web while pulling the bags into position, you may increase tension by 1) sliding the rubber grommets toward the center of the roller and in contact with the bag or 2) pushing the roll chuck inward, applying pressure to the core plugs and then tightening the thumb knob screws that secure the roll chucks into position on the roll shaft.

2.12 Note on Seal Quality

After sealing the first bag and allowing the seal to cool, test the seal for strength by attempting to pull the layers apart. Heat, dwell time and pressure affect the quality of seals. If the seal separates, increase the seal time in small increments. Additionally, check the air pressure and increase the pressure in small increments. After initial startup and after sealing several bags, you may decrease the dwell time slightly.

2.13 Bag Counter / Counter Reset

The T-200 Sealer/Bagger is equipped with a totalizing counter to count finished bags (counts seal operations). Since seal operations are counted, any defective bags must be deducted from the count to determine your production. A slide / locking switch is located on the counter which resets the count to zero and then locks into position. *Note: Since the counter is battery operated, the count will be displayed when the power is turned off.*

T-200 Threading Diagram

Figure 2-1

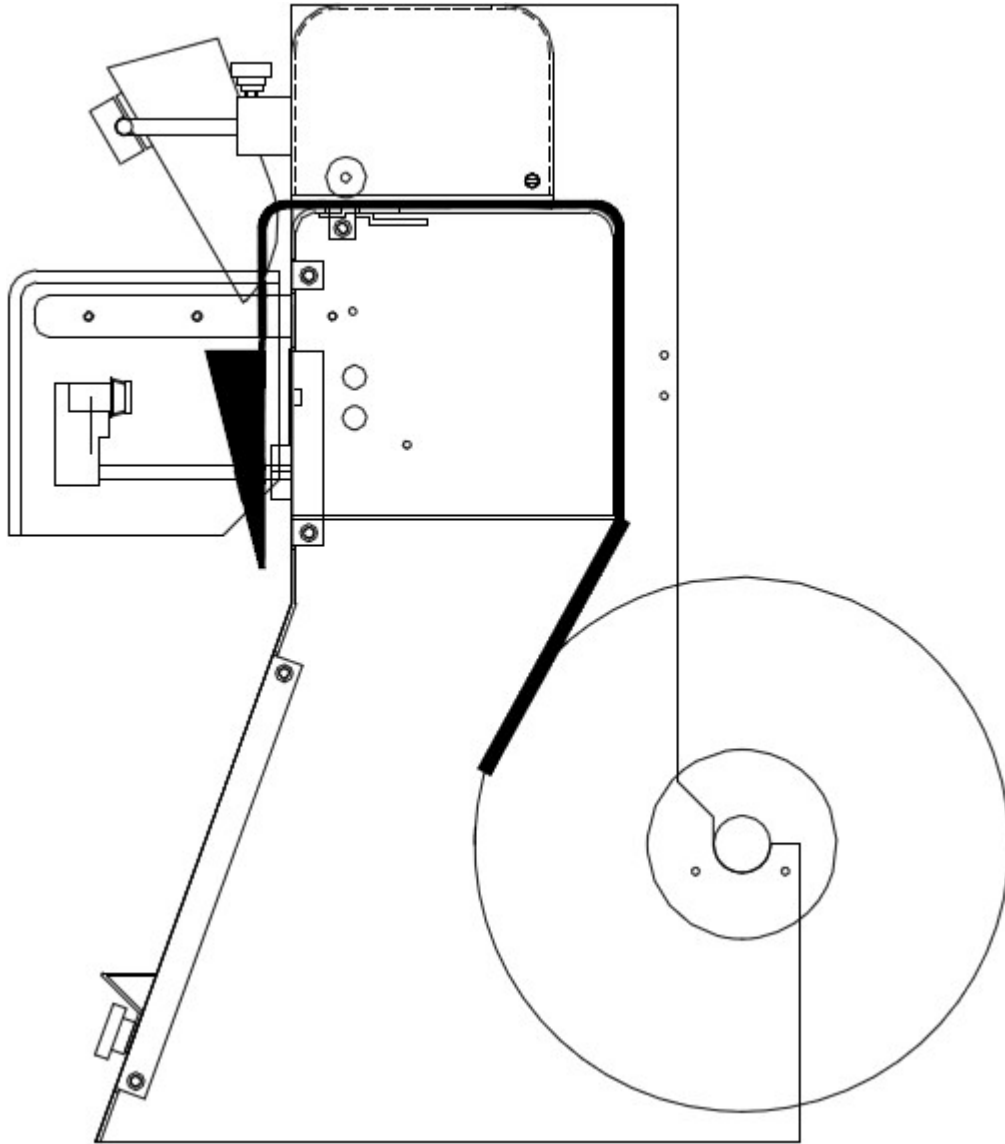

This page intentionally left blank.

Chapter 3: Operation Adjustments / Replacement of Wear Items

Adding PTFE Anti-Stick Material to Rubber Strip and Cleaning
Rubber Strip Replacement
PTFE Anti-Stick Sheet Advancement
PTFE Anti-Stick Sheet Replacement
Heater Cartridge / Thermocouple Replacement
Description of Anti-jam Circuit
Anti-jam Adjustments / Testing
Preventative Maintenance

3.1 Adding PTFE Anti-Stick Material to Rubber Strip and Cleaning

New rubber is often sticky when initially used causing bags to cling to the rubber when sealed. But after a short period, the rubber will become slick and not cling to the bag material. Self-adhesive PTFE Anti-Stick strips may be added to the rubber pressure strip if the product continually sticks to the rubber strip or to improve seal integrity. Periodically clean the rubber strip with alcohol to remove contaminants and plastic buildup.

3.2 Rubber Strip Replacement

Through normal use, the rubber strip will wear causing seal quality problems. The rubber will also wear prematurely if contacting the product during the seal operation. When the wear affects the seal quality, replace the rubber strip by following these procedures:

1. Remove air from the unit, turn the T-200 power “OFF” and unplug the power cord.
2. Remove Lexan Cover.
3. Remove the screws holding the Pressure Bar to the Seal Blocks to take the rubber strip holder out. *Note: Keep hardware in safe place to reuse later.*
4. Remove the worn rubber pad by pulling from the end corner of the rubber strip. Once started, the rubber will easily slide out from the metal pressure strip housing. See Figure 3-1.
5. Clean out the metal slot with alcohol and a cloth or brush.
6. Slide the extruded rubber into the metal housing slot starting at one end and continuing to work the rubber along the length of the slot. When into position, the rubber strip should be loose in the slot.

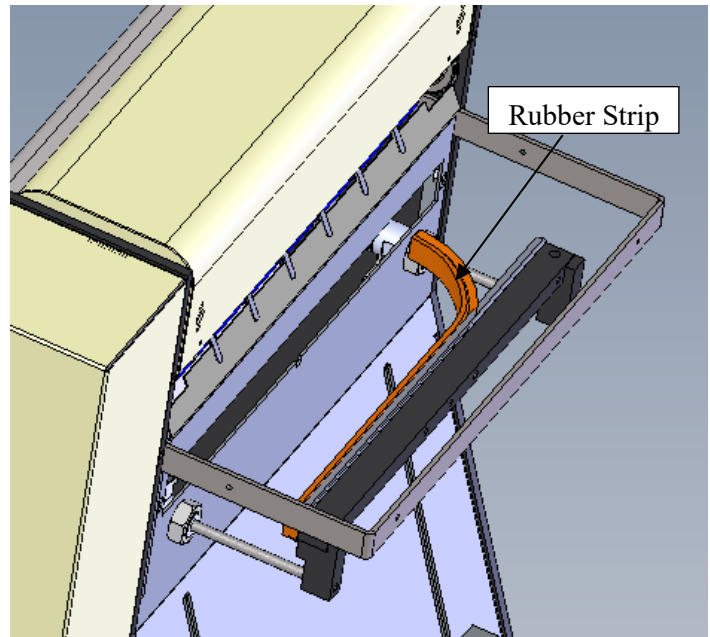

Figure 3-1

CAUTION: *Metal housing for rubber strip has sharp corners and sharp edges. When rubber is removed, carefully clean slot with thick cloth not allowing contact with fingers or hands.*

7. Reattach the Rubber strip holder back to the Seal Blocks using the same hardware from before.

3.3 PTFE Anti-Stick Sheet Advancement

The material will wear with continued use and prematurely tear if contacting the product when sealing. If the material wears or tears affecting the seals, the sheet can be advanced to bring new Material into the seal area. To advance the Material, insert a small flathead (common) screwdriver into the bottom 1/4" hole located on the right side panel of the unit. When you feel the screwdriver enter into the slot of the rod, turn the screwdriver counterclockwise to advance new Material into position.

After turning new material into position, turn the rod clockwise slightly so that there is very little tension on the sheet.

Note: Sheet that is too tight will cause Anti-Jam issues and may also cause the material to tear.

CAUTION: *The following maintenance procedures should only be performed by trained and qualified maintenance technicians.*

3.4 PTFE Anti-Stick Sheet Replacement

When the PTFE Anti-Stick sheet has been exhausted, it will become loose from the upper rod and will require replacement. There are three phases when replacing the PTFE Anti-Stick sheet, Phase 1: Disassembling parts of the machine to get to the PTFE Anti-Stick Bracket, Phase 2: Changing the material, and Phase 3: Reassembling the machine parts taken off to get to the bracket. Use Figure 3-2,

Figure 3-3, and the T-200 Heater Bar Assembly Diagram in 4.2C with the following instructions. Call APPI Service (800)754-4403 if additional help is needed.

Phase 1:

1. Remove air from the unit, turn the T-200 power "OFF" and unplug the power cord.
2. Remove Stainless Steel Cover from back of machine.
3. Lift the funnel assembly and top cover upward.
4. Remove four screws from the guard assembly and remove the Lexan guard, see Figure 3-2.
5. Allow the sealer mechanism to cool for at least 30 minutes.

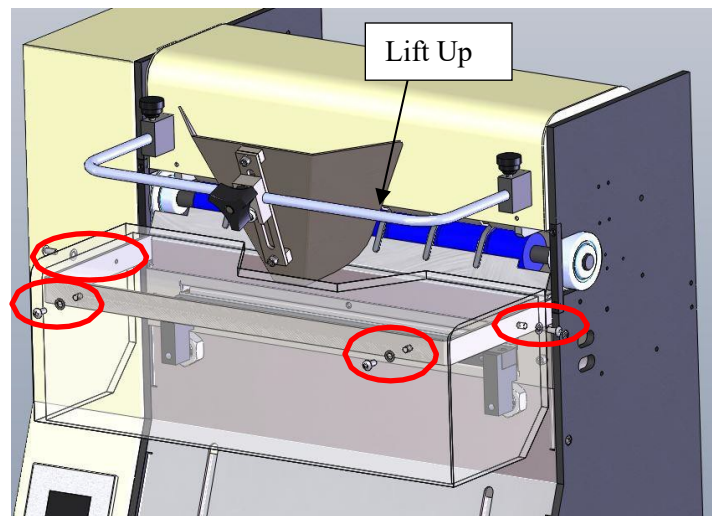

Figure 3-2

6. Remove the two shoulder bolts from the pressure bar (
- 7.
8. Figure 3-3).
9. Remove the Pressure bar and turn down the black pressure bar blocks (
- 10.
11. Figure 3-3).
12. Remove the two screws located on the right and left side of the seal bar which hold the seal assembly mechanism in place (
- 13.13.
14. Figure 3-3).

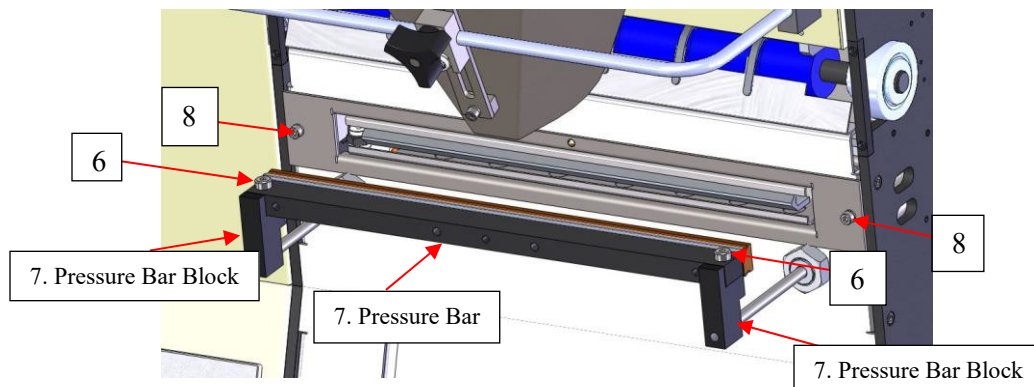

Figure 3-3

15. From the back, unplug the left and right side Anti-Jam Sensors, disconnect the Thermal-Couple, and the left and right Heater Cartridge connectors.
16. From the front, pull one side (right or left side) of the seal assembly out from the front plate. Since the seal assembly is tight, some maneuvering may be required to remove the assembly from the machine, see To avoid damage to components or wiring, do not force the assembly.

Phase 2: (Refer to Heater Bar Assembly Diagram in 4.2B)

17. Remove the two springs (Item 14, TP-102153) holding the shafts together.
18. Remove the Socket Head Bolt and Nut on Each side of the Heater Plate.
19. Remove shafts and PTFE Anti-Stick Sealing Sheet.
20. Clean the adhesive from both shafts.
21. Separate the two shafts.
22. Lay one Shaft on the top of the sheet and measure from the edge of the sheet to the edge of the Shaft. Ensure the sheet is in the center of the Shaft.
23. Wrap a piece of tape on the Shaft at the edge of the Sheet.
24. Take the second Shaft, lay the first Shaft next to it and wrap tape around the end of the second Shaft in exactly the same place as the first. Keep the taped ends on the same side of the Sheet.
25. Remove the adhesive backing from one end of the Sheet.
26. Align one Shaft parallel to the Sheet with the taped end of the Shaft meeting up with the edge of the PTFE Anti-Stick Sealing Sheet. Once the shaft is in position, lower onto adhesive side of the sheet.
27. Roll the Shaft until you reach the end of the adhesive part.
28. Repeat with the other Shaft, ensuring the taped ends are on the same side. Once the PTFE Anti-Stick Sealing Sheet has been rolled over the Shafts, the tape may be removed.
29. Lay Heater Plate on a flat surface so the side plates stick up. Lay PTFE Anti-Stick Sealing sheet over the Heater Plate so that the shafts are parallel to the plate and the sheet will roll on the outside of the shaft when reattached.

30. Place the Heater Bar on top of the sheet so that it fits through the rectangle window through the Heater Plate. The sheet will be between the Heater Plate and Heater Bar.
31. Replace the 2 socket head bolts and nuts.
32. Replace Shafts and springs.

Phase 3:

33. Slide Heater Bar Assembly back in.

CAUTION: When facing the T-200, the motor is on the left side. When reinserting the Heater Bar Assembly use caution not to bump the motor as it will dislocate the Anti-Jam Circuit Board.

34. Replace and tighten socket head bolts.
35. Reinstall Pressure Bar.
36. Put a light film of grease on Shoulder Bolts and tighten.
37. Attach Lexan Cover
38. Connect Thermal Couple.
39. Reconnect right and left Heater Bar Connectors.
40. Reconnect both Heater Bar Sensors.
41. Replace Stainless Cover.

3.5 Heater Cartridge / Thermocouple Replacement

Since the heater cartridges are a normal wear item, they will require replacement when burned out, worn or damaged. Heater bar life span may be increased by timely adjustment of the PTFE Anti-Stick Sealing, avoiding an exposed heater bar. The heater bar cartridges are two cylindrical cartridges inserted in both ends of the heater bar. If the heater bar is slow to reach the set temperature, one or both of the heater cartridges may require replacement. Call APPI Service at (800)754-4403 for replacement instructions.

3.6 Description of Anti-jam Circuit

The anti-jam mechanism decreases the possibility of damage to the T-200 if product or other objects are in the seal area. The operation of the anti-jam circuit should be tested prior to production on a daily basis. To test the anti-jam circuit, see Chapter 2, Section 2.4.

Although the anti-jam unit may also prevent or decrease the opportunity for injuries during the sealing or heating operation, the anti-jam is not designed as a safety device. If not adjusted properly, damage may result from obstructions in the seal area or personal injury may result from fingers or hands being in the seal area when sealing.

If properly adjusted, a jam is detected when: 1) the rubber pressure strip does not contact the PTFE Anti-Stick Sealing material at one or both sides of the Anti-Stick Shield or 2) the spring-loaded Anti-Stick Shield is pressed prior to the rubber pressure strip contacting the Anti-Stick Shield.

If these conditions are met, the pressure seal bar will retract and heat will not be applied to the heater element.

The anti-jam mechanism consists of: 1) two cylinder magnetic switches which detect the cylinder position and 2) two sensors that detect the spring-loaded Anti-Stick Shield “U” channel position.

3.7 Anti-jam Adjustments / Testing

If the anti-jam circuit is not functioning properly, contact APPI Service for troubleshooting instructions.

3.8 Preventative Maintenance

The following maintenance items should be performed by the operator or maintenance personnel to prolong the life of the equipment. Failure to perform these tasks may result in premature wear, personal injury or equipment damage.

Item:	Description:	Frequency:
Anti-jam	Test anti-jam prior to production	Daily
Pressure	Check air pressure to ensure 60-70 PSI	Daily
PTFE	Inspect for wear / holes, turn 1/4" if required	Daily
Rollers	Clean with Isopropyl Alcohol	Daily
Rubber Strip	Clean rubber strip with Isopropyl Alcohol	Weekly
Cylinders	Remove air and push in manually to ensure free movement with no binding.	Weekly
Pressure Bar	Remove air and push in manually to ensure free movement with no binding	Weekly
Springs	Inspect for cracks in springs, ensure free movement	Monthly
Wiring	Ensure no loose contacts or worn shielding	Monthly
Fasteners	Tighten mounting bolts and fasteners	Monthly
Blower filter	Clean/replace if air flow decreases	Monthly
Electronics	Remove covers and blow out compartments	Monthly

Chapter 4: Parts Identification

Recommended Spare Parts List
Parts / Component Identification
Pneumatic Diagram
Wiring Diagram

4.1 Recommended Spare Parts List

The following spare parts kit is recommended for your inventory and includes components which can easily be replaced. These items are either wear items or other components which may fail during the day to day operation of the machine.

Level 1 (TO-T8-SP10) Spare Parts Kit		
PART NO	DESCRIPTION	QTY
TP-T8MA00140	Seal Bar Rubber Strip	1
TP-T8MA00130	PTFE Sheet	1
TP-108153	Extension Springs	2
TP-406181	4 Micron Filter	1
TP-214215	O-Rings	5
TP-402255	Solenoid Valve	2
TP-403148	Pneumatic Cylinders	2
TP-T8ME0161	Anti-Jam Sensor Board Assembly.	2
TP-T8ME0161-1	Pig Tail for Anti-Jam Board	2
TP-207026	Fuse, 8 Amps / 250V	2
TP-221416	Thermocouple Wire with Connect	1
TP-215022	Switch, Snap-Action, General P	1
TP-108099	Compression Spring, Guide Roll	2

4.2 Parts / Component Identification

This section includes assembly drawings of the T-200. Please use APPI part numbers whenever possible to order replacement parts. You can also refer to Drawing Numbers and Corresponding Item Numbers on the drawings to assist in determining the required components. See sections A-E.

4.3 Pneumatic Diagram

Refer to Dwg NO. T-200 PNE, section F, for the Pneumatics diagram.

4.4 Wiring Diagram

Refer to Dwg, Section G, for T200 Table Top Bagger with PLC wiring diagram.

A.

T-200 System Layout

PN: T-T200

ITEM NO.	QTY.	PART NO	DESCRIPTION
1	1	TA-T8-1000	ELECTRONICS ASSEMBLY
2	1	TA-T8-2000	HEATER BAR ASSEMBLY
3	1	TA-T8-4000	MAIN FRAME ASSEMBLY

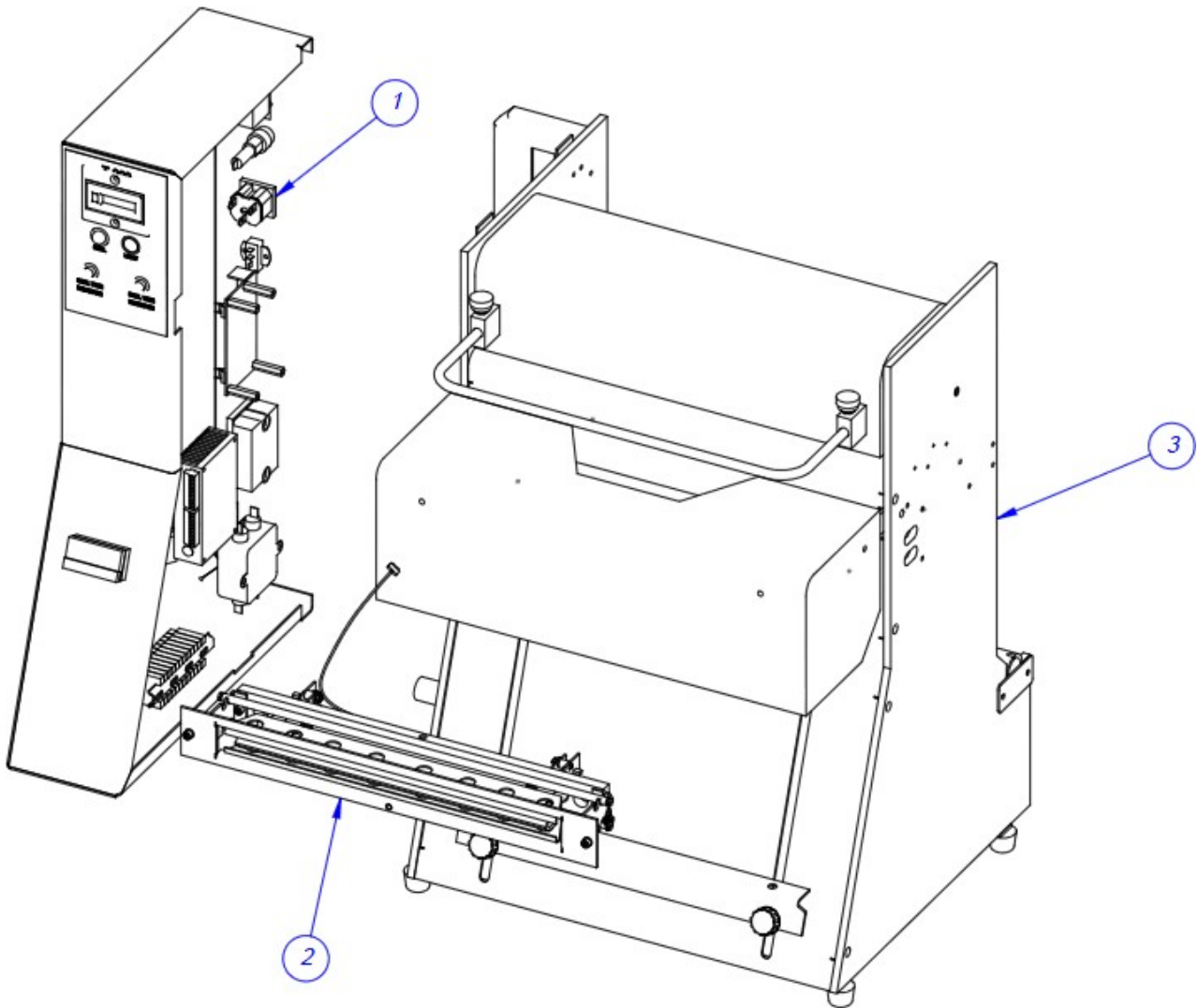

B. T-200 Electronics Assembly

PN: TA-T8-1000

ITEM NO.	QTY.	PART NO	DESCRIPTION
1	1	TP-112240	POWER CORD STRAIN RELIEF
2	1	TP-205108	EMI FILTER, CORCOM
3	1	TP-207216	FUSE HOLDER
4	1	TP-212410	AC OUTLET
5	4	TP-214279	STAND-OFF 1"
6	1	TP-213407	SWITCHING POWER SUPPLY
7	1	TP-215000	SOLID STATE RELAY
8	1	TP-215019	COUNTER
9	1	TP-215384	POWER SWITCH
10	1	TP-220512	PLC
11	1	TP-215000A	COVER
12	1	TP-218021	DIN RAIL
13	12	TP- 208142	LARGE TERMINAL BLOCK
14	1	TP-212242	3 PIN SOCKET W/ BRACKET
15	1	TP-224050	CONTROLLER
16	1	TP-204011	LED - GREEN
17	1	TP-204135	LED - YELLOW
18	2	TP-215029	MOMONTARY SWITCH

T-200 Electronics Assembly
PN: TA-T8-1000

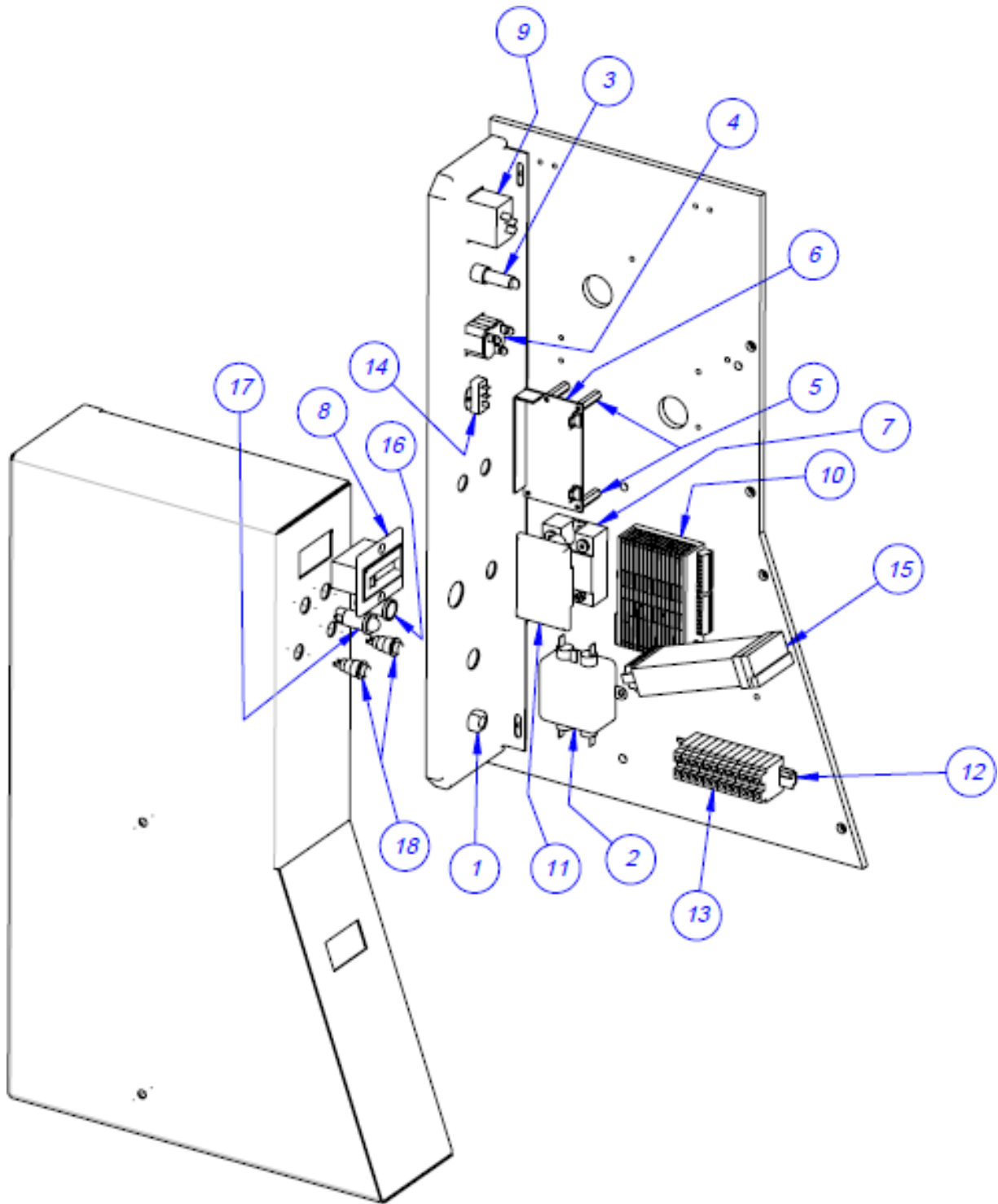

C. T-200 Heater Bar Assembly

PN: TA-T8-2000

ITEM NO.	QTY.	PART NO	DESCRIPTION
1	1	TP-T8MA00121-5	HEATER PLATE & BRACKET SUB-ASM.
2	1	TP-T8MA00112-1	BRACE
3	2	TP-T8MA00226	PHOTO EYE BRACKET
4	1	TP-T8MA00199	ANTI-JAM
5	1	TP-T8MA00202	SEAL BAR
6	2	TP-T8ME0161	ANTI JAM SENSOR BOARD ASM.
7	2	TP-T8MA00227	HEATER BAR SLIDE
8	2	TP-109210	THUMB SCREW
9	4	TP-104135	STANDOFF, NYLON SPACER
10	2	TP-T8MA00124	PTFE SHAFT
11	2	TP-101103	SAE NUTS
12	2	TP- T8MA00231	ROUND UNIT SPACER
13	2	TP- 108099	COMPRESSION SPRING, .040 GUAGE, .359 OD.
14	2	TP-108153	EXTENSION SPRING
15	1	TP-T8MA00225	BLOW OFF TUBE
16	1	TP-221416	THERMAL-COUPLE WIRE

Note: This assembly is used in both the T-200 and T-275 table-top baggers. Part No. TP-T8MA0025 Blow Off tube (item 15) is only used when the assembly is made for the T-275 model.

T-200 Heater Bar Assembly

PN: TA-T8-2000

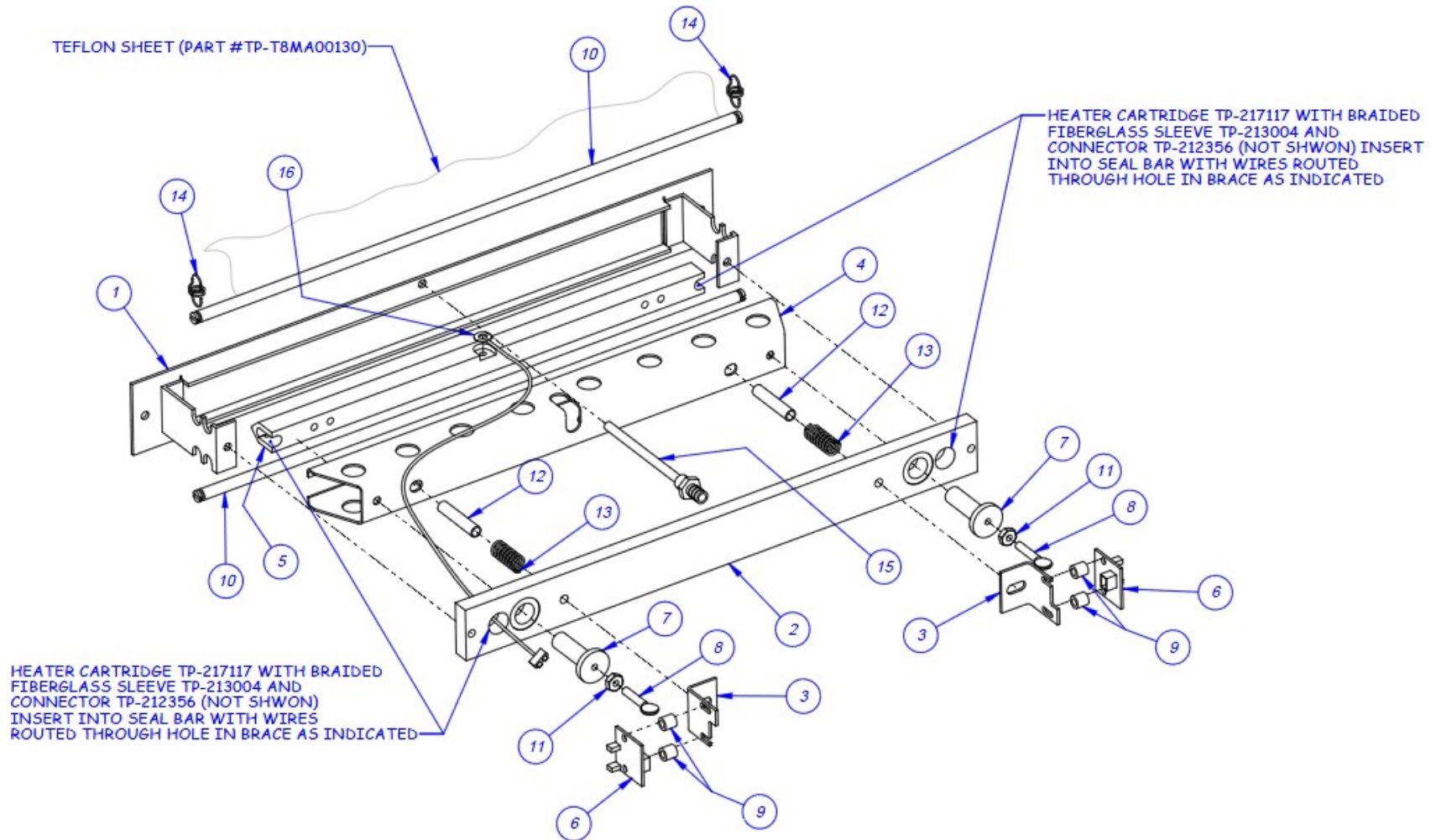

D.

T-200 Main Frame Assembly

PN: TA-T8-4000

ITEM NO.	QTY.	PART NO	DESCRIPTION
1	1	TP-T8MA00100	FRONT COVER
2	1	TP-T8MA00116	LEFT MAIN PLATE
3	1	TP-T8MA00117	RIGHT MAIN PLATE
4	1	TP-T8MA00101	SIDE COVER
5	1	TP-T8MA00103	ELECTRONICS PANEL
6	2	TP-T8MA00115	STANDOFF
7	1	TP-T8MA00104	BLOWER HOUSING
8	1	TP-T8MA00134	BLOWER BRACKET
9	1	TP-T8MA00111	BACK PANEL TEMPLATE
10	1	TP-T8MA00107	BLOWER BRACKET
11	1	TP-405268	AIR KNIFE
12	2	TP-T8MA00138	ROD MOUNTS
13	1	TP-T8MA00136	FUNNEL MOUNT
14	1	TP-T8MA00106	COVER
15	2	TP-T8MA00131	COVER MOUNT
16	2	TP-T8MA00108	COVER HANGER
17	1	TP-T8MA00133	HOUSING SHAFT
18	1	TP-T8MA00128	GUARD MOUNT
19	2	TP-403148	AIR CYLINDER
20	2	TP-T8MA00118	SEALER BLOCK
21	1	TP-T8MA00126	LOAD SHELF
22	1	TP-T8MA00127	BAG ROLL SHAFT
23	1	TP-T8MA00132	ROLLER STOP
24	1	TP-T8MA00129	LEXAN GUARD
25	1	TP-T8MA00139	REGULATOR MOUNT
26	2	TP- T1MA00049	FILM TENSION HUB
27	2	TP-109152	KNOB
28	2	TP-109213	THREADED KNOB, #10-32 X 7/16 STUD
29	1	TP-401253	BULKHEAD CONNECTOR
30	1	TP-401222	HEX NIPPLE
31	1	TP-402107	FLOW CONTROL VALVE
32	1	TP-406258	MINI REGULATOR
33	1	TP-T8MA00173	BRACE
34	1	TP-T8MA00165	MYLAR DECAL
35	1	TP-T8MA00110	PRESSURE BAR HOLDER
36	1	TP-T8MA00109	RUBBER STRIP HOLDER
37	1	TP-T8MA00140	RUBBER STRIP
38	1	TP-T8MA00113	DANCER GUIDE ROLLER SHAFT

ITEM NO.	QTY.	PART NO	DESCRIPTION
39	2	TP-504101	FILM ROLLER BEARING
40	1	TP-T8MA00114	GUIDE ROLLER
41	1	TP- 406181	AIR FLOW FILTER
42	1	TP-401292	STRAIGHT CONNECTOR, 1/4" TUBE X 1/4 NPT
43	1	TP-401291	1/4" X 1/4" ELBOW
44	1	TP-402262	TWO STATION MANIFOLD
45	3	TP-401134	HEX PLUG
46	1	TP-215022	LIMIT SWITCH
47	1	TP-401257	ELBOW, 1/4" TUBE X 1/8 NPT
48	2	TP-404262	MUFFLER
49	2	TP-402255	VALVE
50	1	TP-406012	THREADED GAUGE
51	2	TP-108168	EXTENSION SPRING
52	4	TP-112300	BUMPER, RUBBER TAPERED 7/8" X 5/8"

T-200 Main Frame Assembly

PN: TA-T8-4000

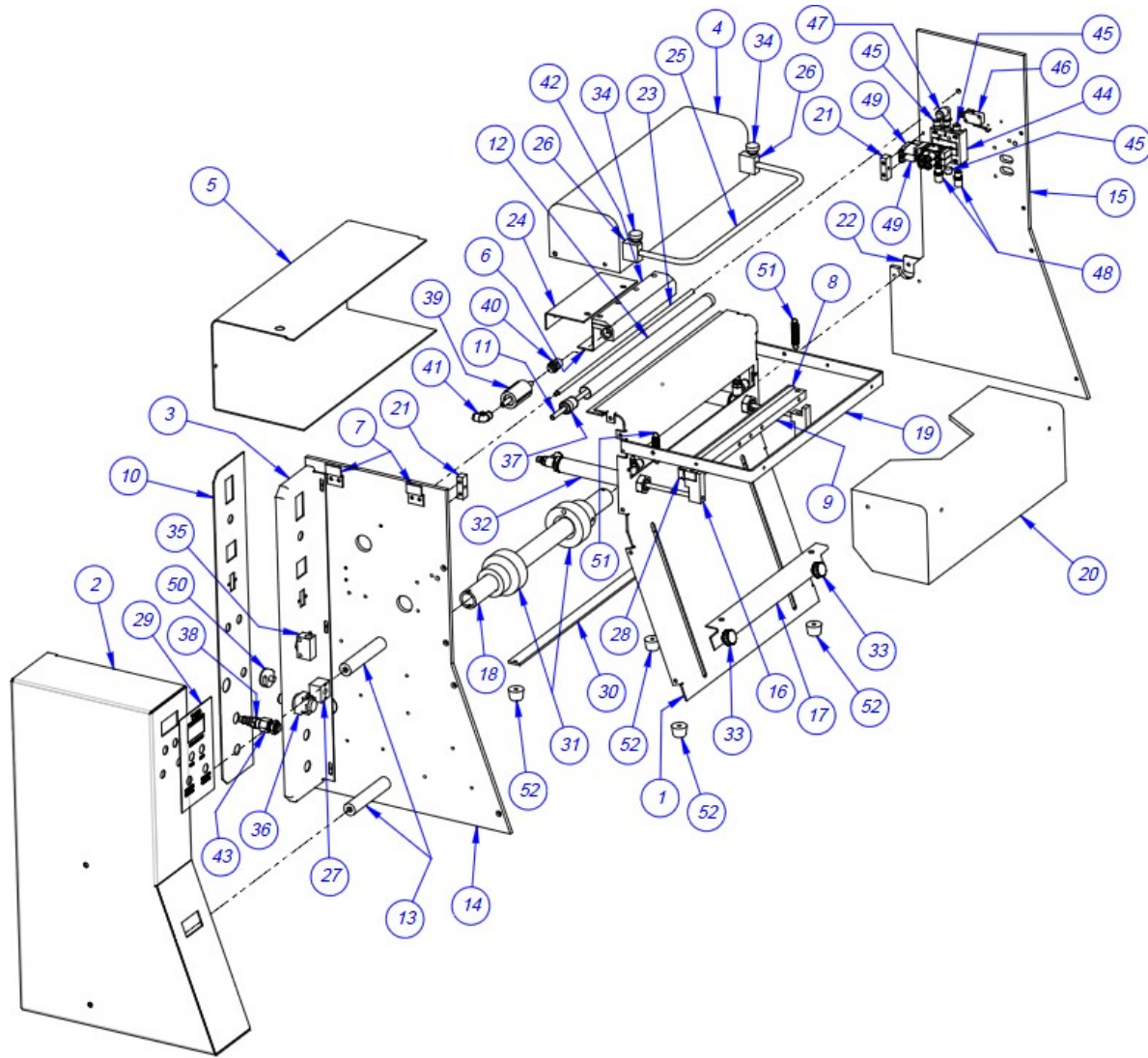

E.

T-200 Adjustable Chute Assembly

PN: TA-T8-9000

ITEM NO.	QTY.	PART NO	DESCRIPTION
1	1	TP-T8MA00141	FUNNEL
2	1	TP-T8MA00143	ADJUSTING BAR
3	1	TP-T8MA00142	FUNNEL MOUNT
4	1	TP-109161	CLAMPING KNOB
5	1	TP-103245	1/4-20 x 1-1/2 CARRAGE BOLT
6	1	TP-101143	1/4-20 NYLOCK
7	2	TP-102153	Washer, #8 LOCK
8	2	TP-103015	Screw, SHCS 8-32 x 3/8
9	1	TP-103225	Screw, BHCS 1/4-20 x 3/4"

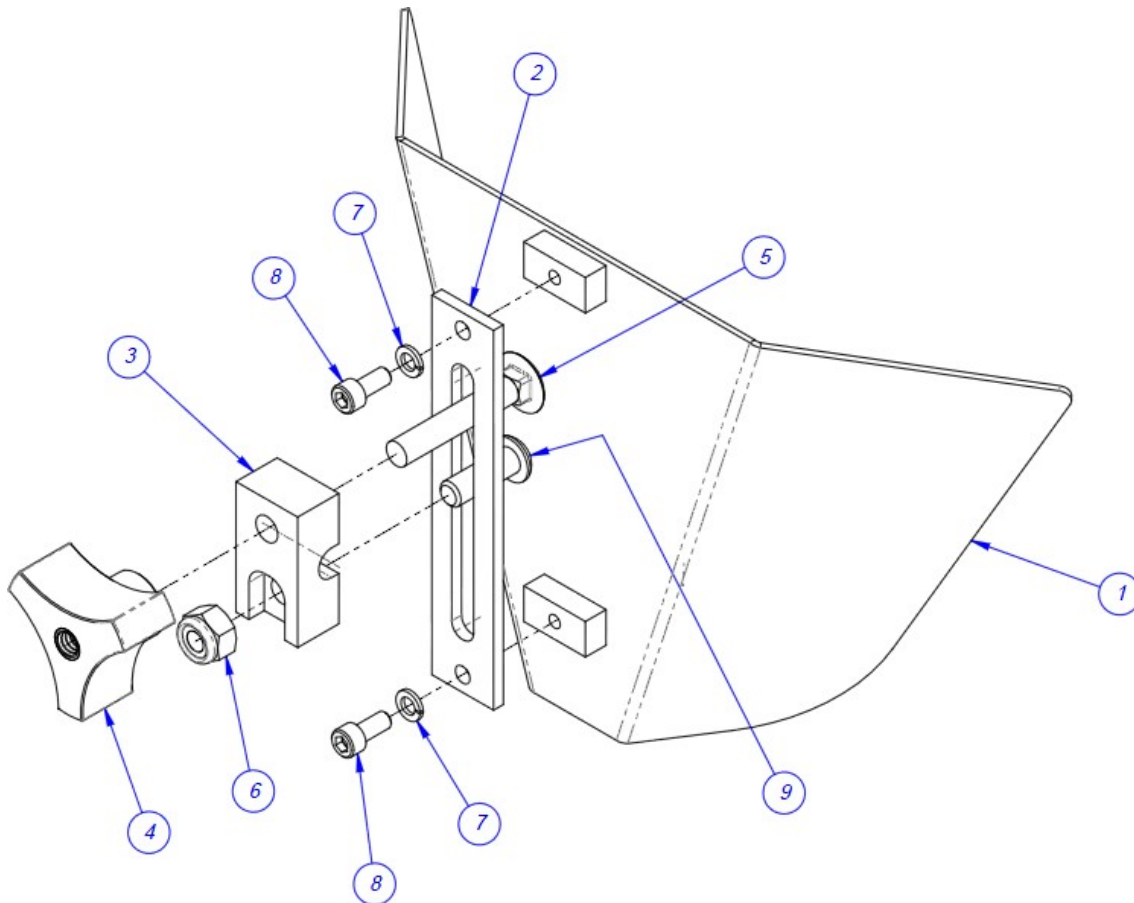

F.

T-200 Pneumatic Layout

Dwg NO.: T-200 PNE

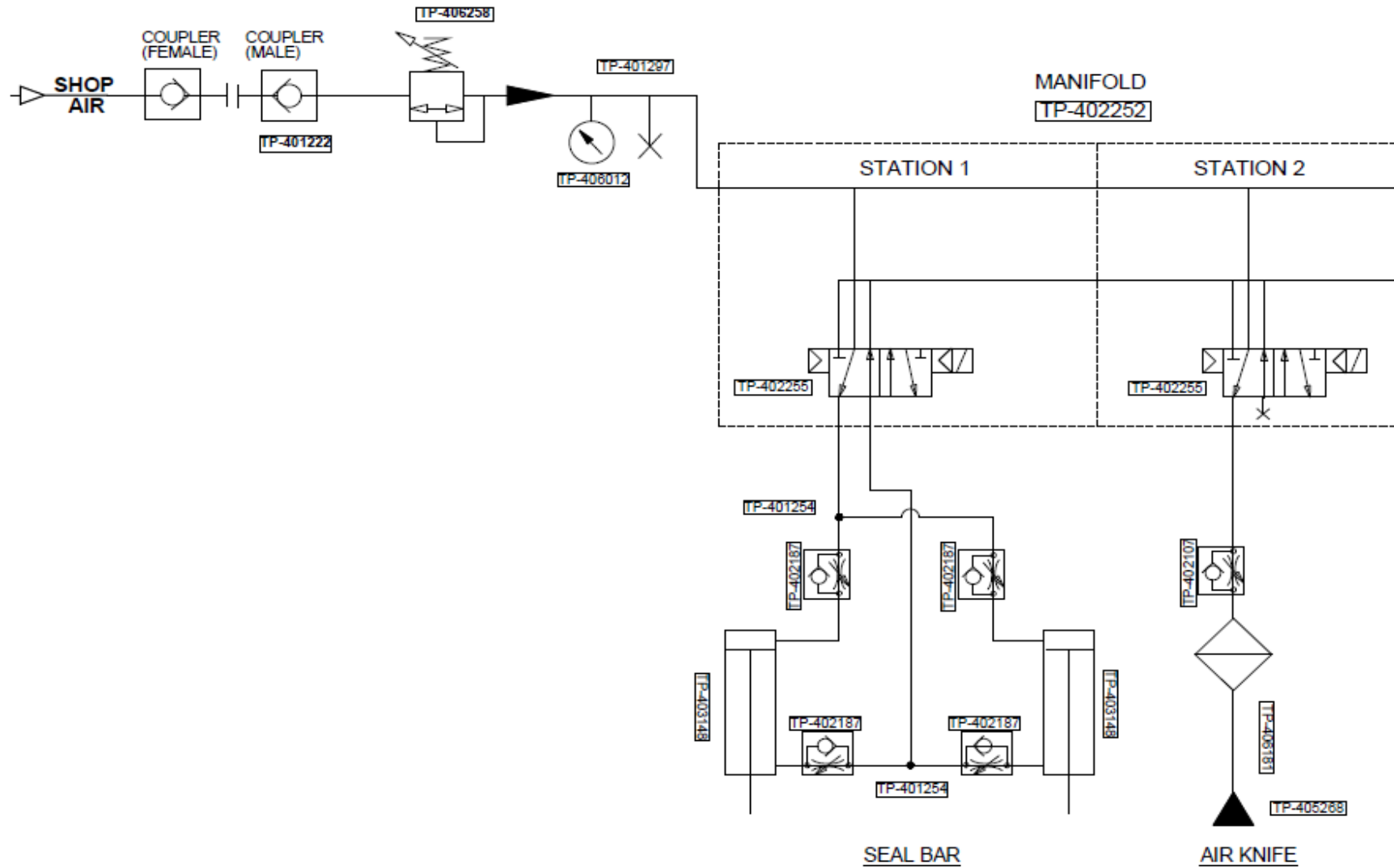

G. T-200 Electrical Layout

T200 TABLE TOP BAGGER WITH PLC

