



How To

Service Documents from APPI

Document: #HT000123

Document Title: Replace PTFE Anti-Stick Sheet

Product(s): T-300/375

Procedure:

If your Bagger has a **Main Power Lockout Switch**, turn it counter-clockwise to **OFF**.

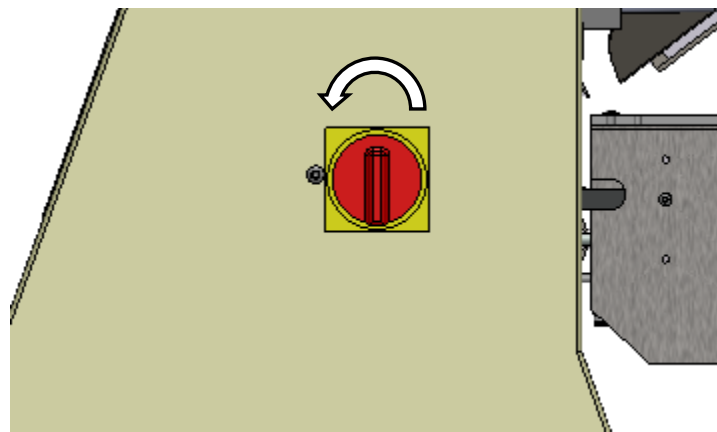

Remove the two Button Head Screws holding the **Side Panel** on and remove **Side Panel**.

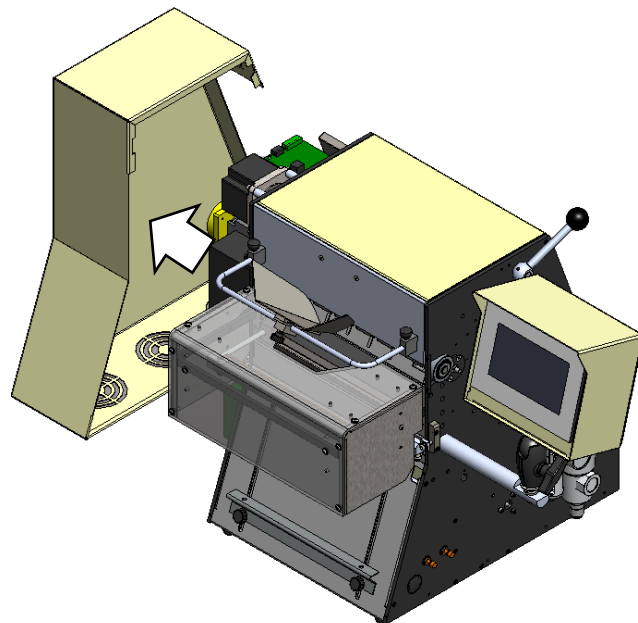



How To

Service Documents from APPI

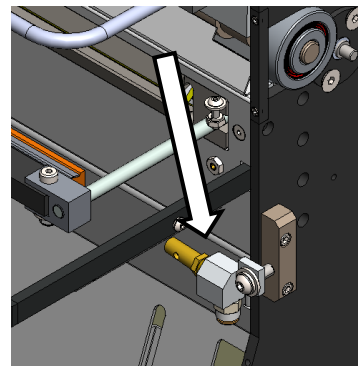
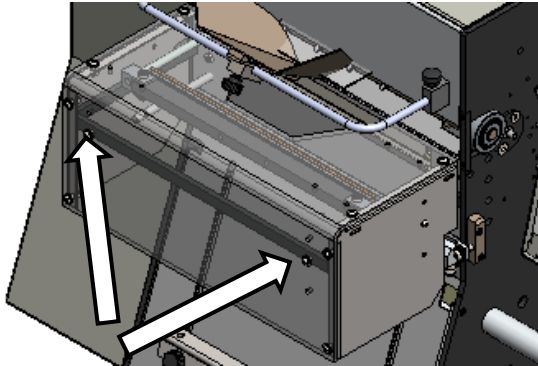

Remove Button Head screws; remove Lexan Cover. Remove Bag Blow Off.

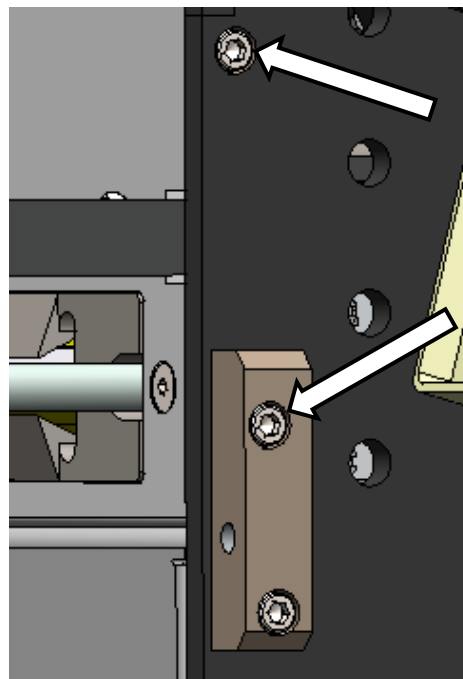

Remove the two #8 Socket Head Screws on the Right side of the Bagger.



How To

Service Documents from APPI

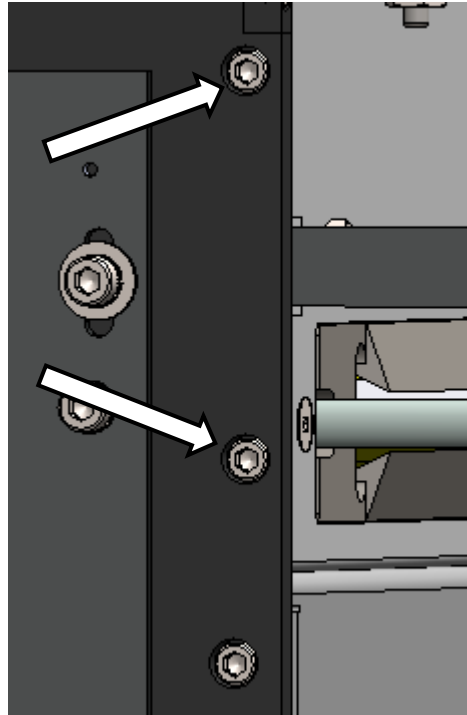

Remove the two #8 Socket Head Screws on the Left side of the Bagger (one may have a green ground wire attached to it).

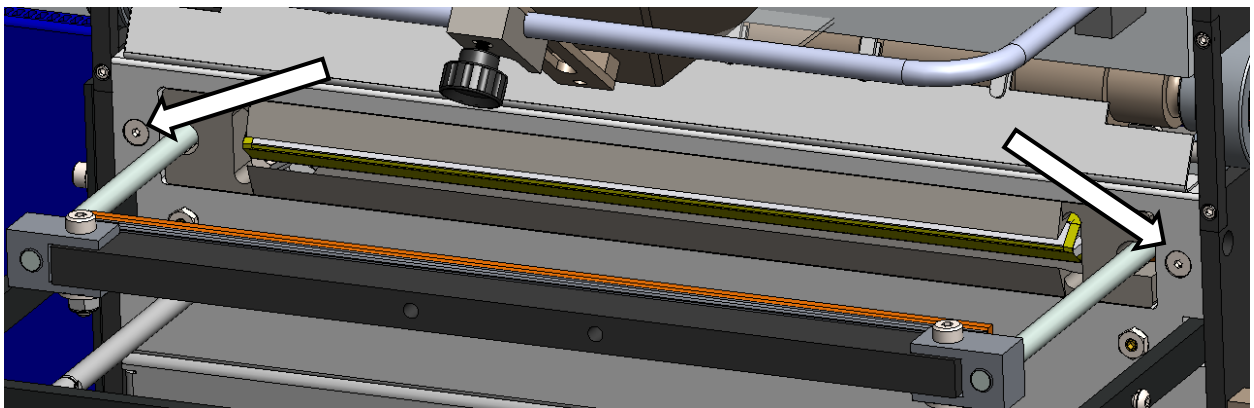

Unscrew and remove the two #8 Flat Head Screws from the Front Plate.



How To

Service Documents from APPI

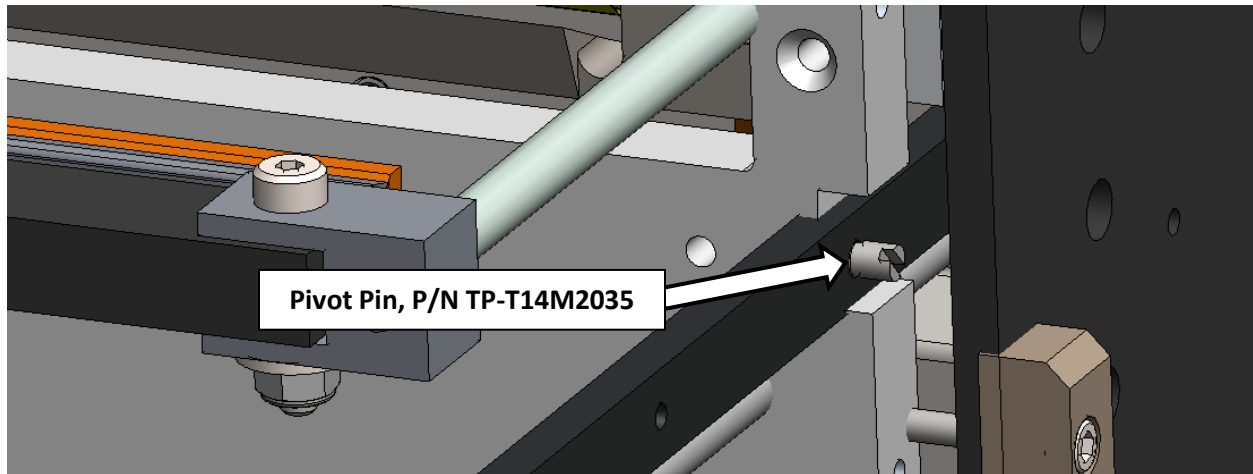

Carefully pull Front Plate and Lexan Guard Bracket out and unscrew the Pivot Pins on both sides of the Front Plate.

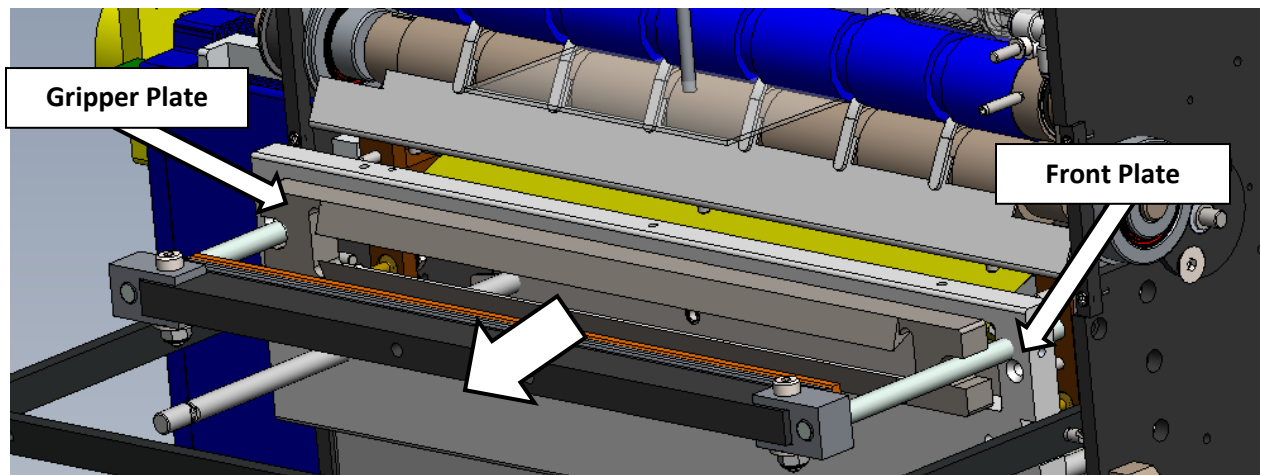

Slide the Gripper Plate and Front Plate out.



How To

Service Documents from APPI

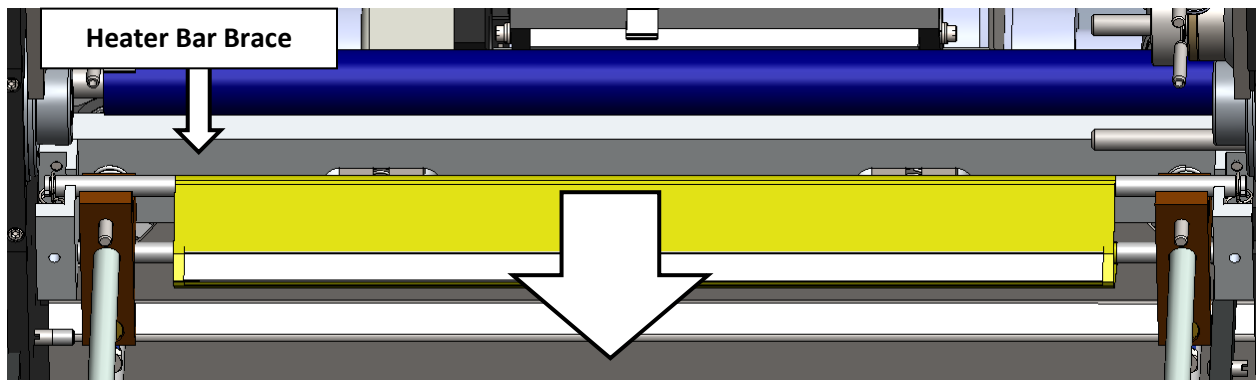

Slide the heater Bar Brace out.

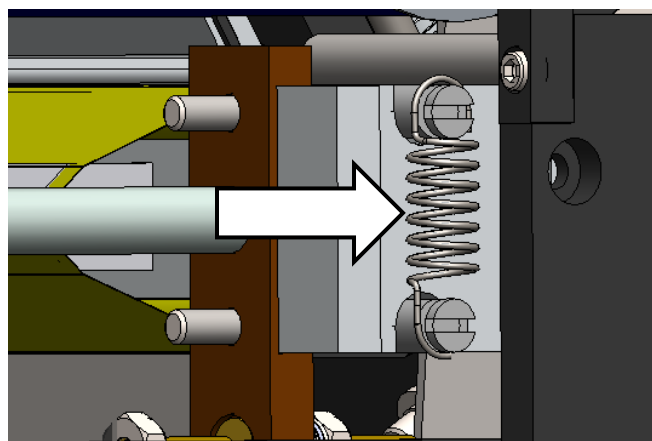
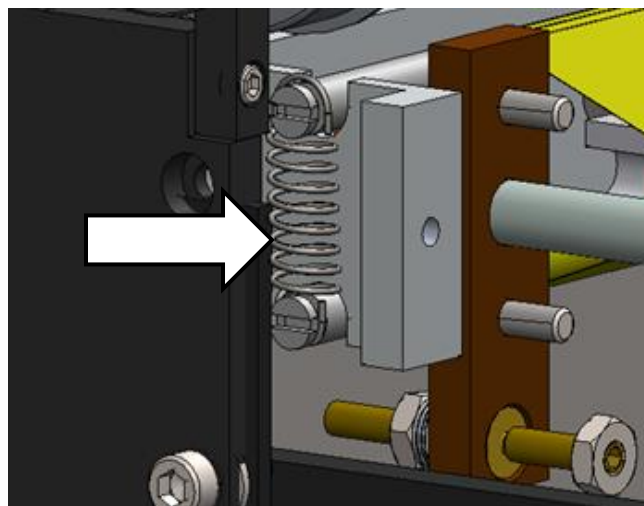

Remove the right and left Springs that hold the PTFE Sheet Shafts in place.



How To

Service Documents from APPI



With a piece of tape, mark where the edge of PTFE Sheet is on the Shafts.
Remove old PTFE Sheet.

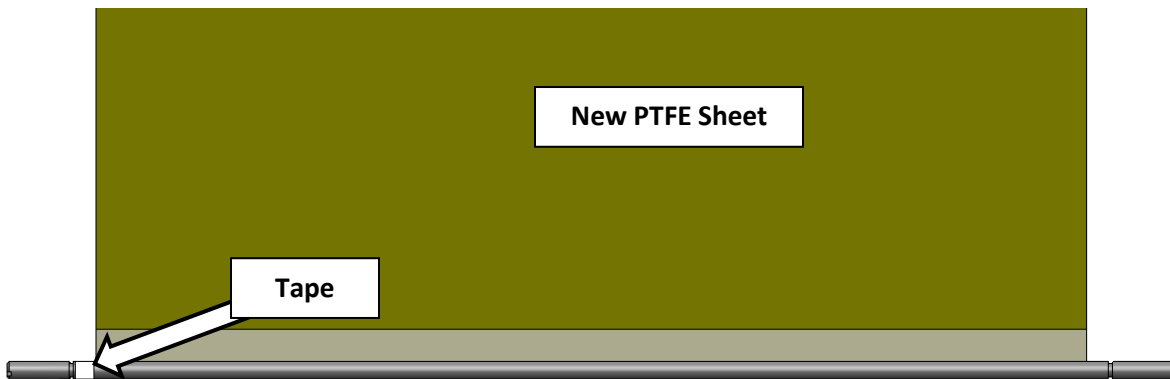

Line up and center the new PTFE Sheet with the tape marks.



Remove adhesive backing cover, and position shaft on PTFE Sheet, then roll on.





How To

Service Documents from APPI

Repeat for the other end of the Shaft, making certain both ends are rolling in the same direction as shown below

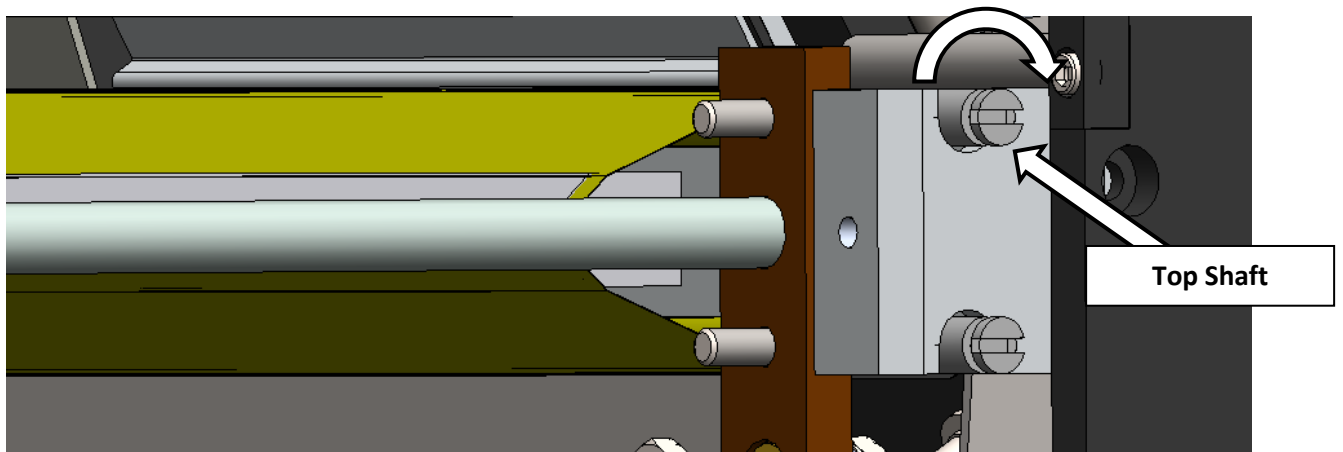
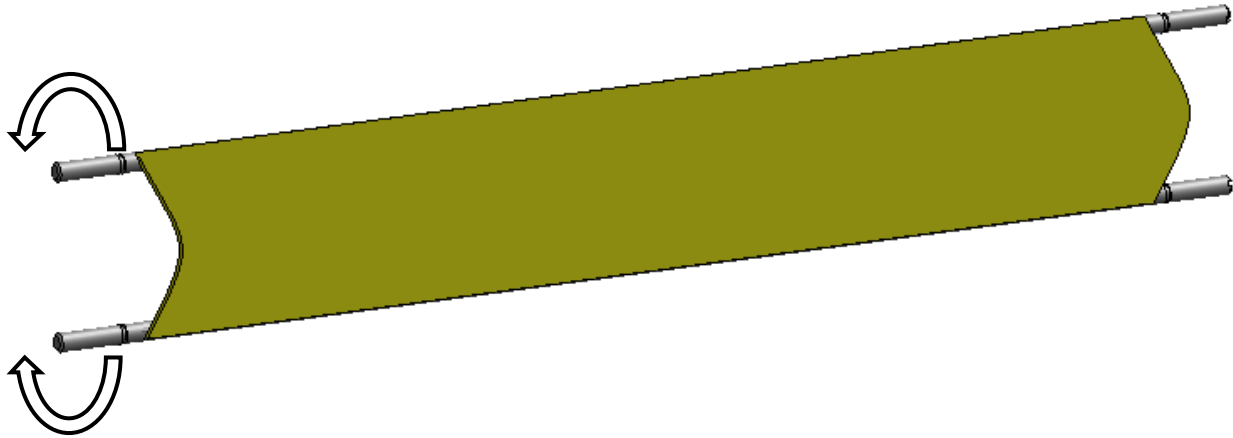

The Top Shaft is the Supply Shaft, so wind the PTFE onto the Top Shaft.



How To

Service Documents from APPI

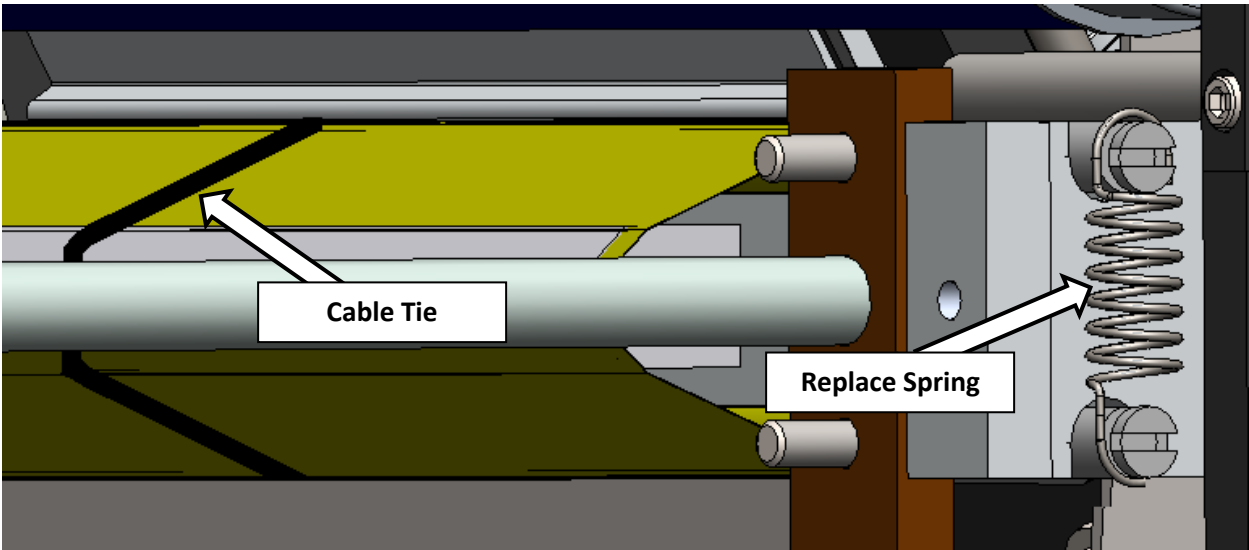

Put a Cable Tie around both PTFE Shafts to hold them in place while replacing the Springs. Remove Cable Tie after Springs are in place.

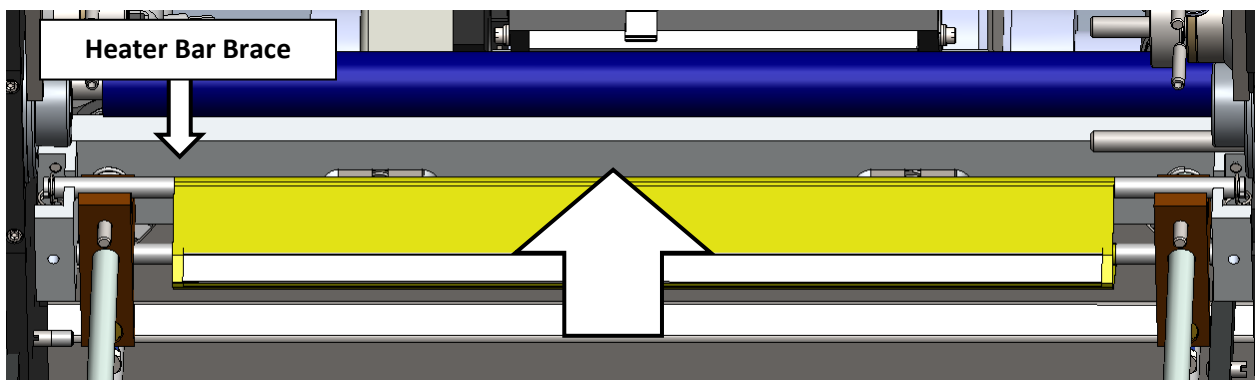

Slide Heater Bar Brace back into place.



How To

Service Documents from APPI

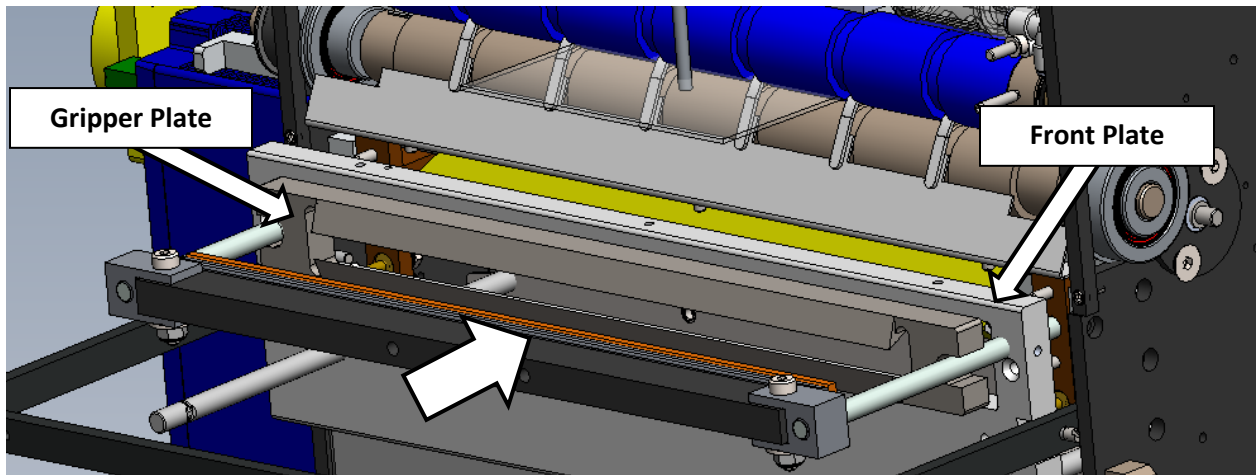

Slide Gripper Plate and Front Plate back to line up with Pivot Pin Hole.

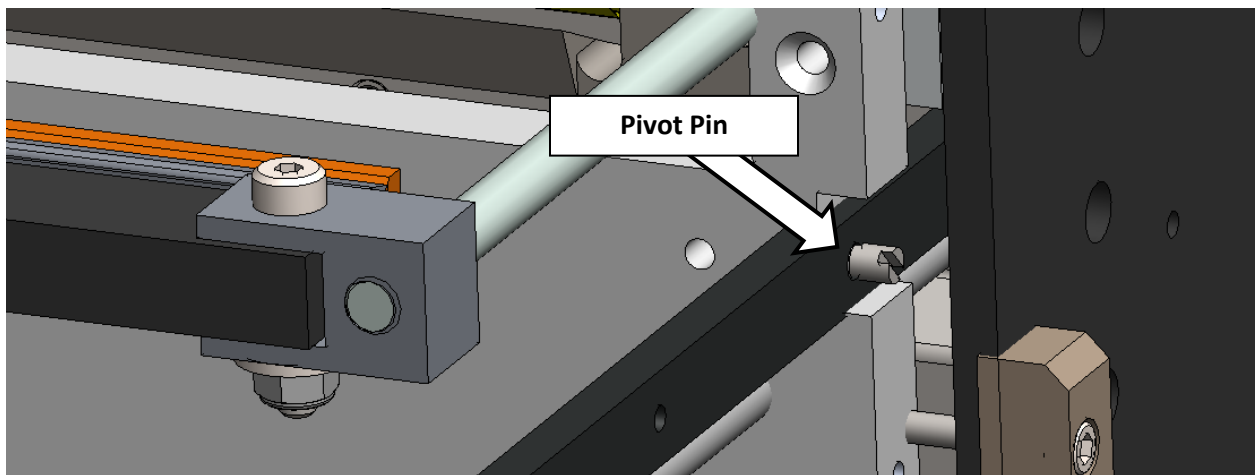

Insert Pivot Pin and screw in. (BOTH SIDES). Slide Gripper Plate and Front Plate back into position.

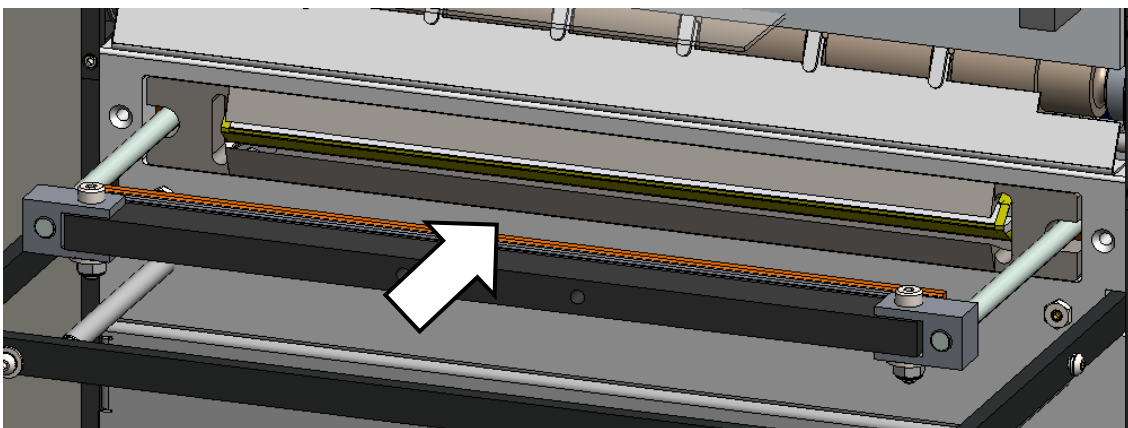



How To

Service Documents from APPI

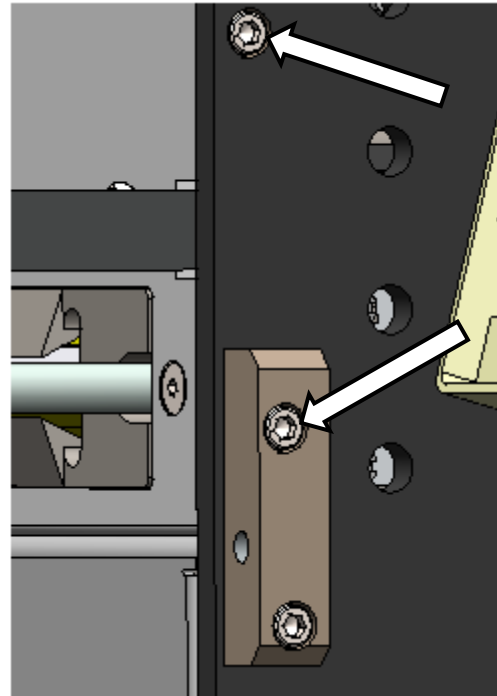
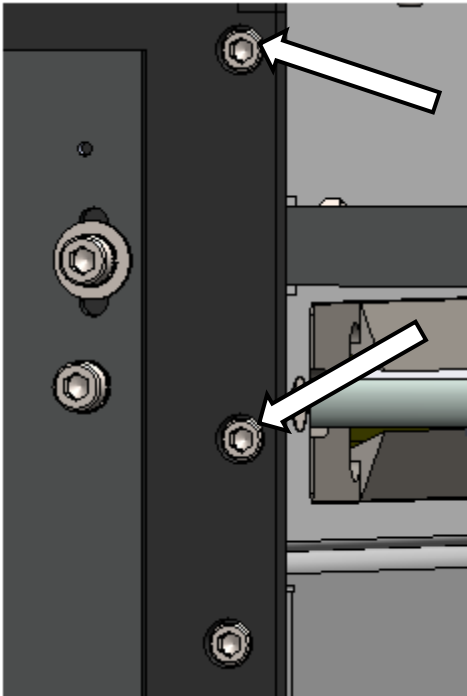

Replace #8 screws on both sides. Reconnect Ground Wire.

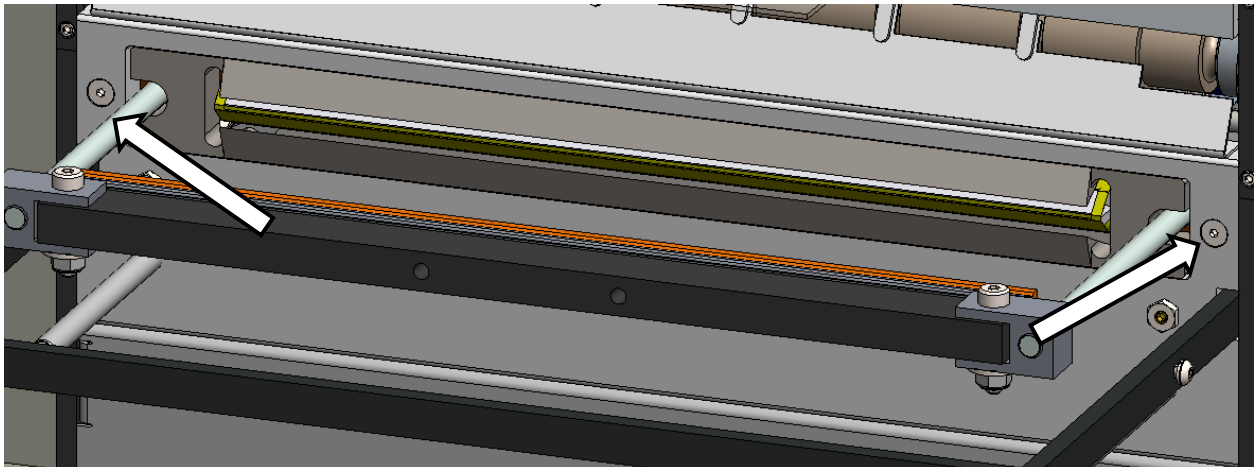

Replace the 2 Flat Head Screws into Front Plate. It may help to reach behind and push the Heater Bar Brace forward to the Front Plate.



How To

Service Documents from APPI

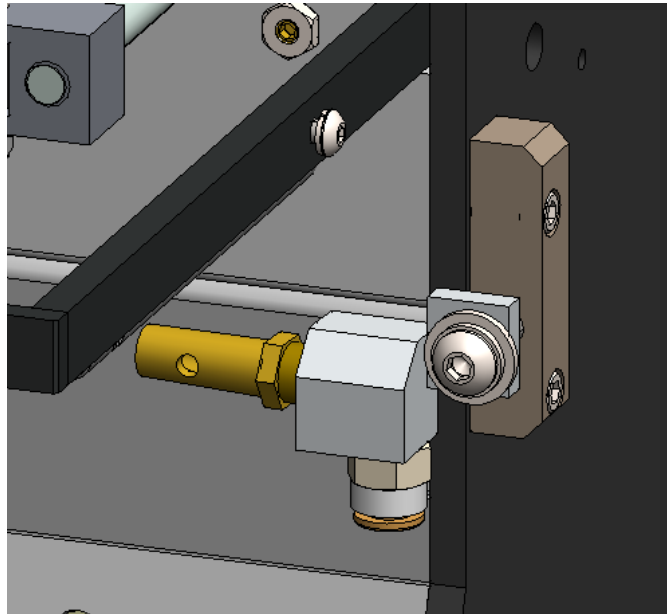

Re-attach Bag Blow Off.

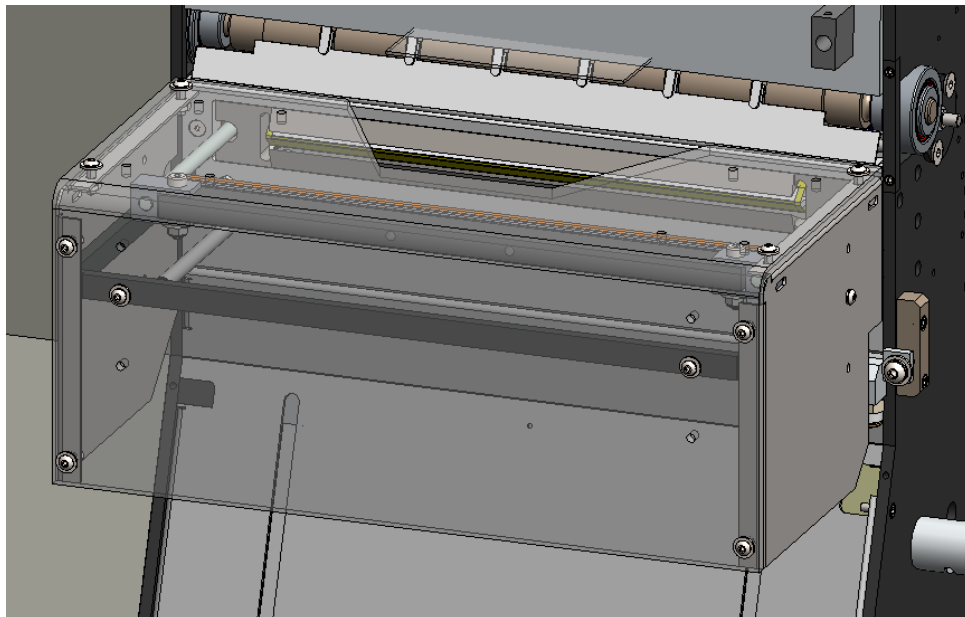

Replace Lexan Cover and Button Screws.