



How To

Service Documents from APPI

Document: #HT000052

Document Title: Air Valve Replacement

Product(s): T-1000

Procedure:

There are two different Solenoid Air Valves used on the T-1000 S14:

- Valves with Orange Buttons
- Valves with Orange and Green Buttons

Note: The Air Valve and Manifold Assembly have been removed from the T-1000 S14 Bagger for photo purposes only. It is not necessary to remove the Manifold for the following operations.

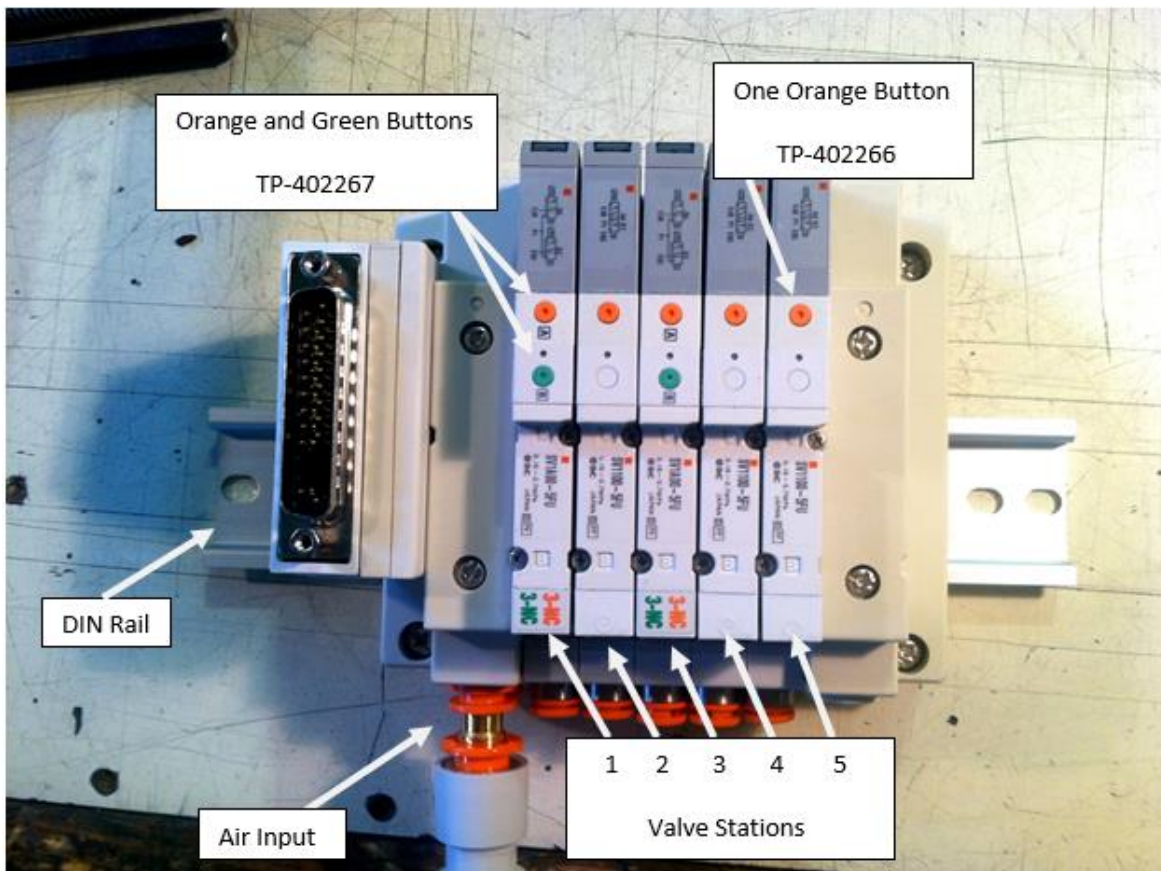



How To

Service Documents from APPI

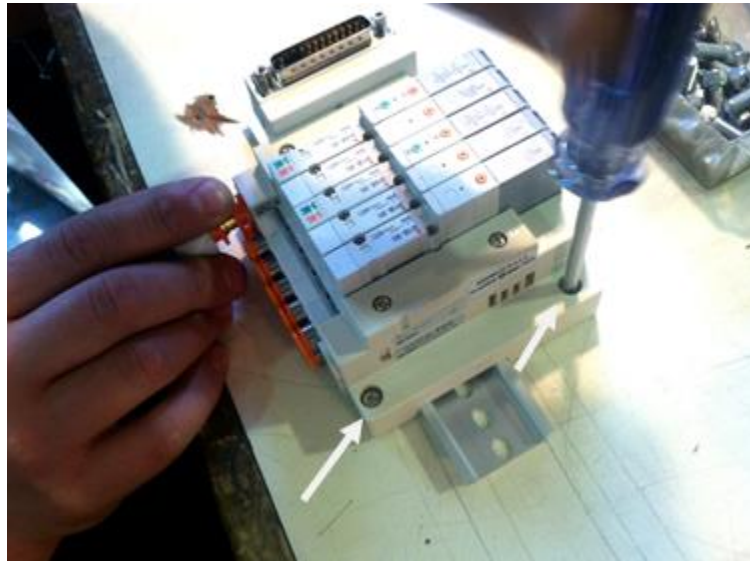

With a Phillips Screw Driver loosen the two screws on the Manifold Block.



With a small Screw Driver gently lift the Lock Tab.



How To

Service Documents from APPI



Slide the Manifold Block off.

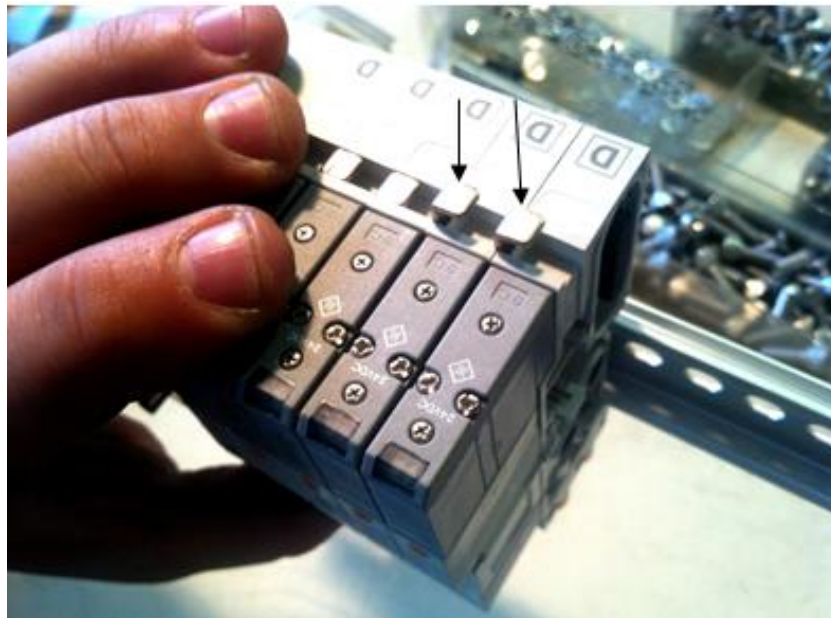

Lift the Lock Tabs up



How To

Service Documents from APPI

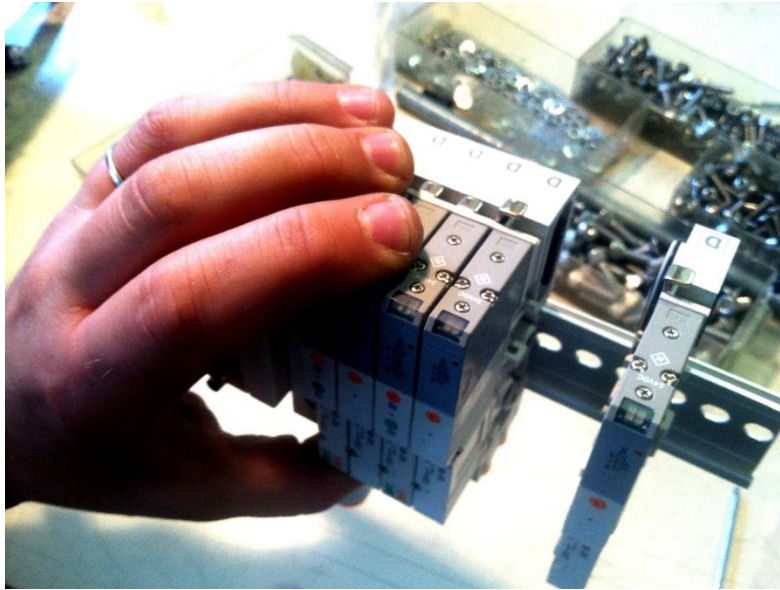

Slide the Air Valve off.

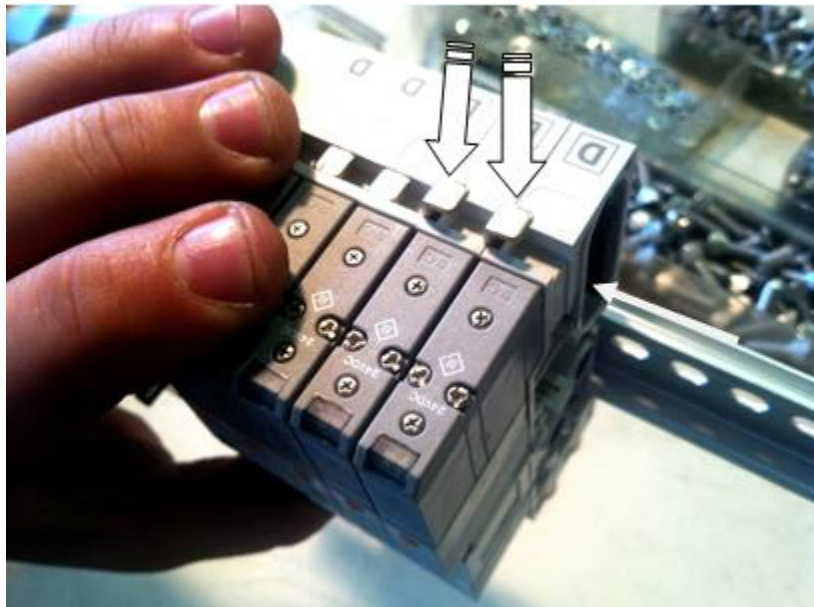

Slide the new Air Valve On. Push down the Lock Tabs.



How To

Service Documents from APPI

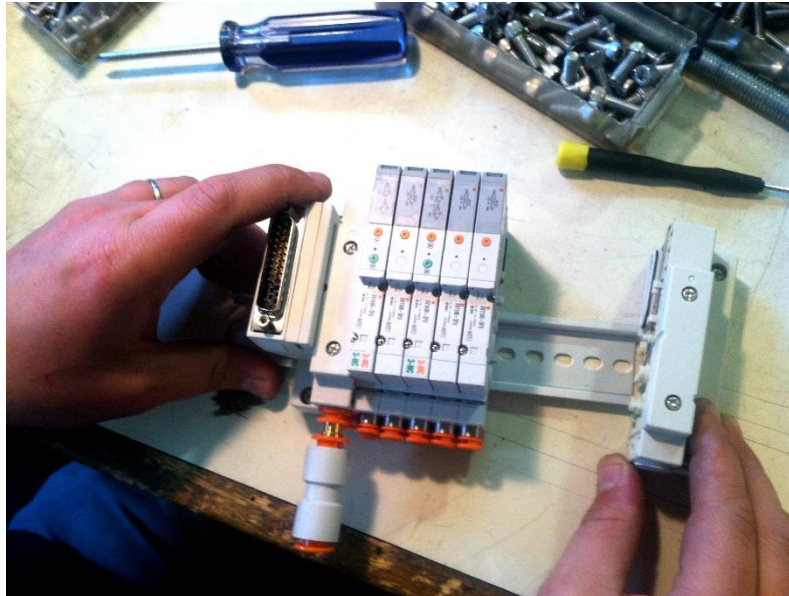

Slide the Manifold Block on.



Push down the Lock Tab.



How To

Service Documents from APPI



Gently tighten both Phillips Screws.

Important: When reassembling valves, check that all gaskets are in place, and in good condition.

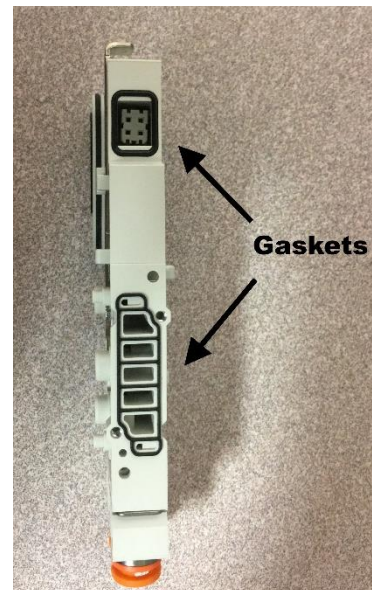
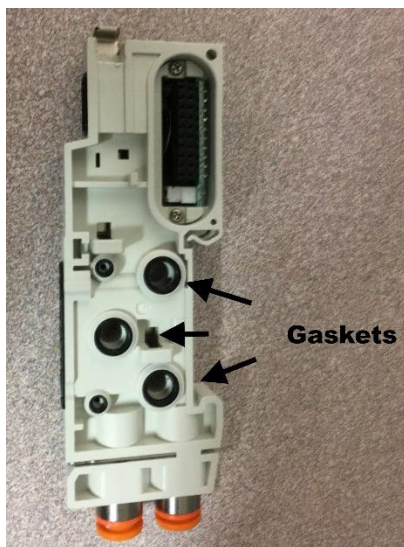



How To

Service Documents from APPI

