



# How To

Service Documents from APPI

**Document: #HT000126**

**Document Title: Printhead Upgrade Instructions (TO-T2Z-300DPI-UPGRADE)**

**Product(s): Ti-1000Z**

**Procedure:**

Turn Main Power OFF, and remove Side Panel.

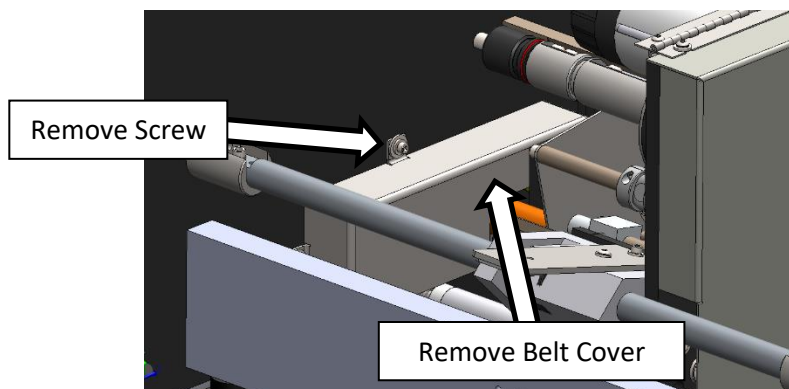
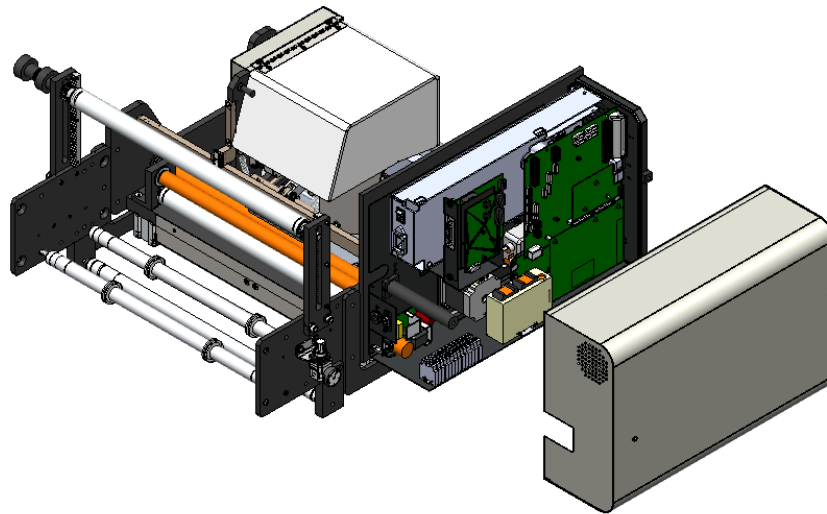

Remove screw and Belt Cover



# How To

## Service Documents from APPI

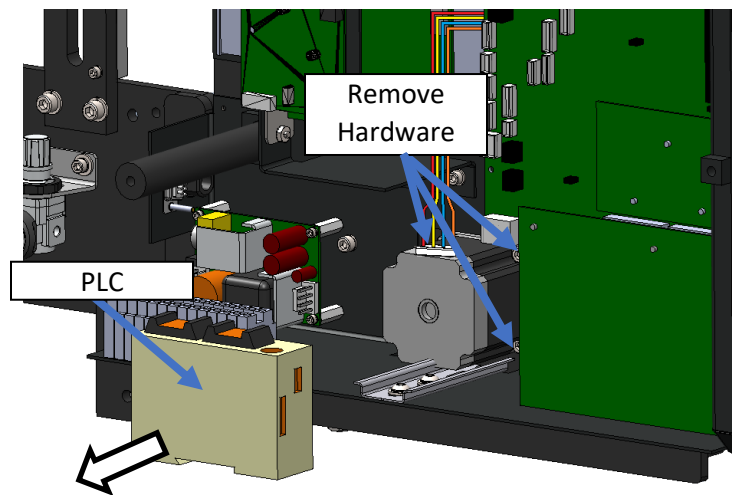
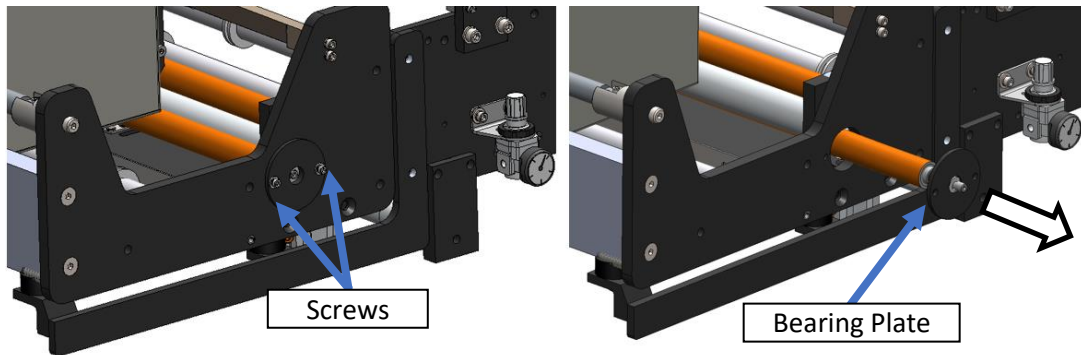

In Electronics Panel, remove PLC from DIN Rail. Remove Motor Hardware.

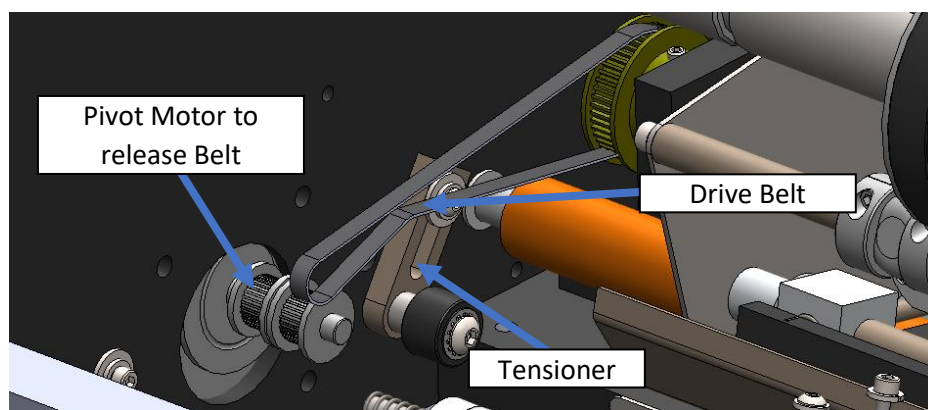

Loosen Tensioner, release Motor & pivot, and remove Drive Belt.



# How To

## Service Documents from APPI

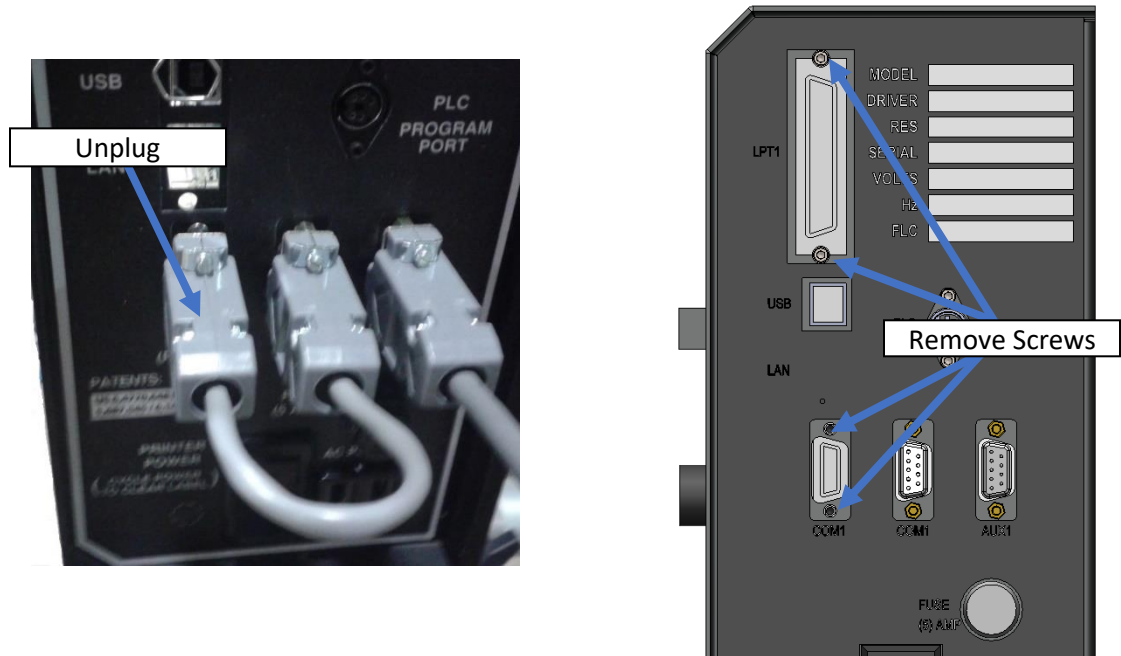

Unplug D-SUB Jumper Cable from COM1, and remove screws from COM1 and LPT1 Connectors to release Logic Board.

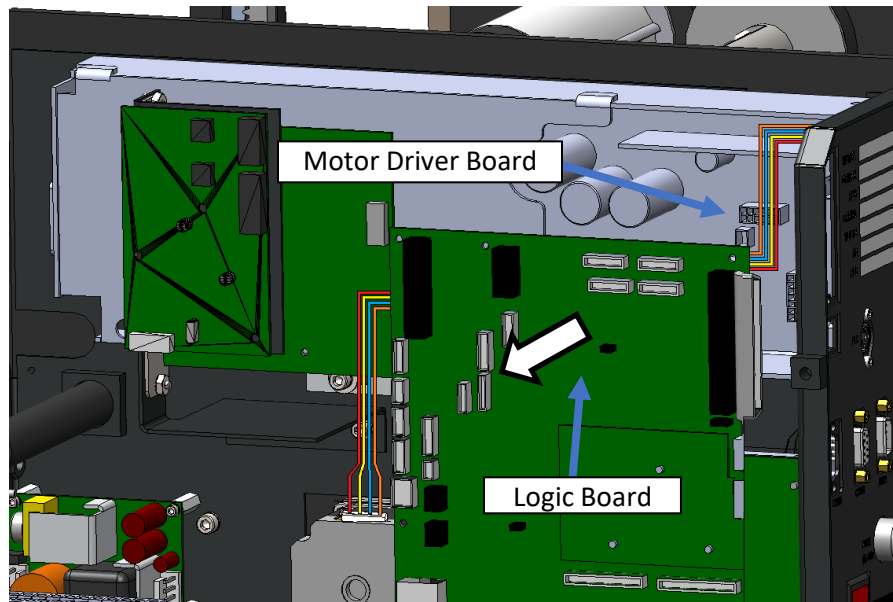

Move Logic Board to allow access to Motor Driver Board.



# How To

## Service Documents from APPI

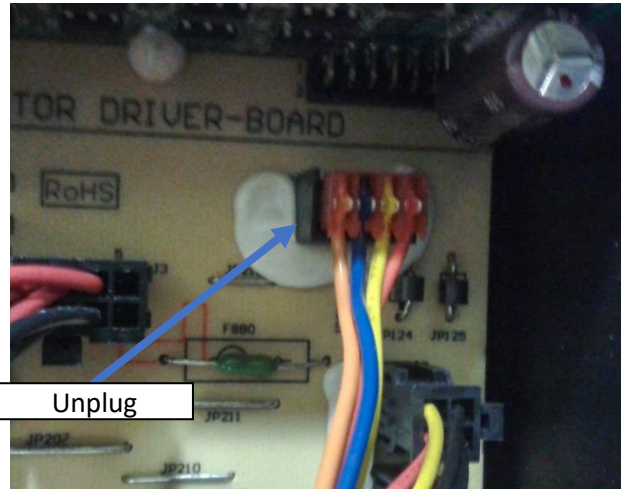

Unplug Stepper Motor cable from Motor Driver Board.

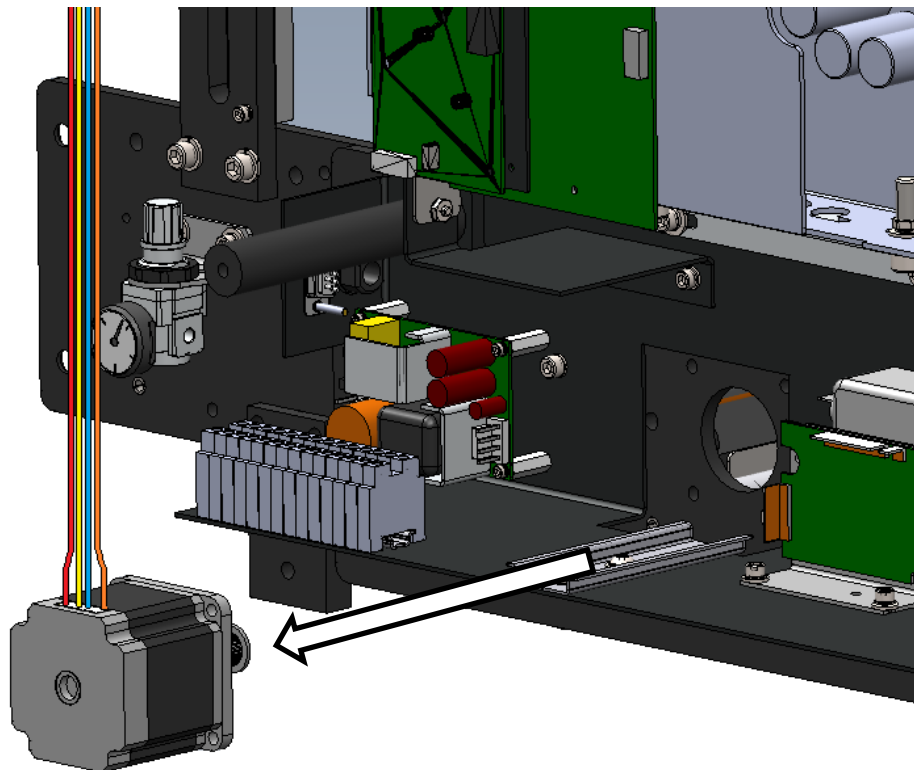

Remove Stepper Motor from module.



# How To

## Service Documents from APPI

Install new Stepper Motor using hardware from previous Stepper Motor. Do not tighten Motor until new Belt is in place. Plug Stepper Motor Cable into Motor Driver Board. Replace and secure Logic Board.

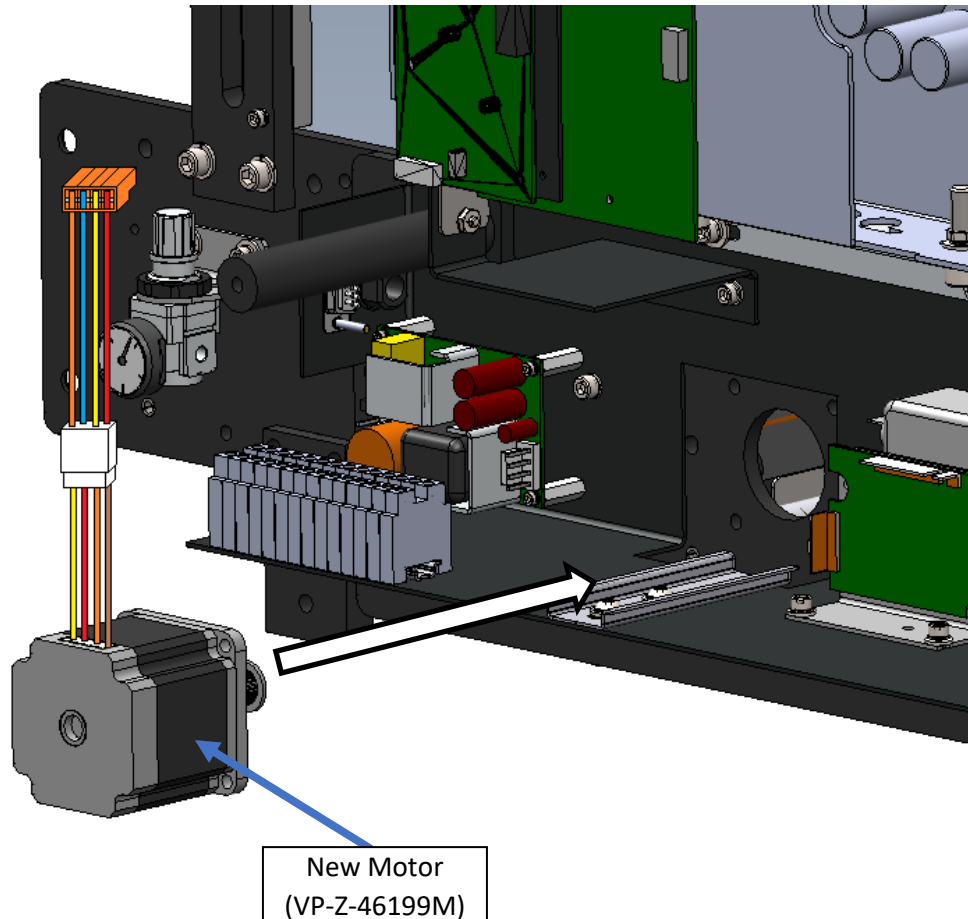



# How To

## Service Documents from APPI

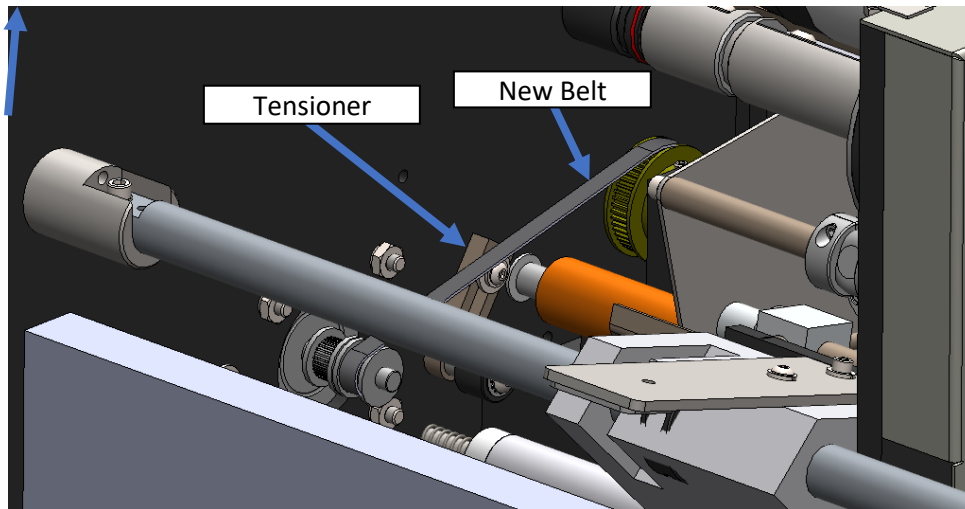
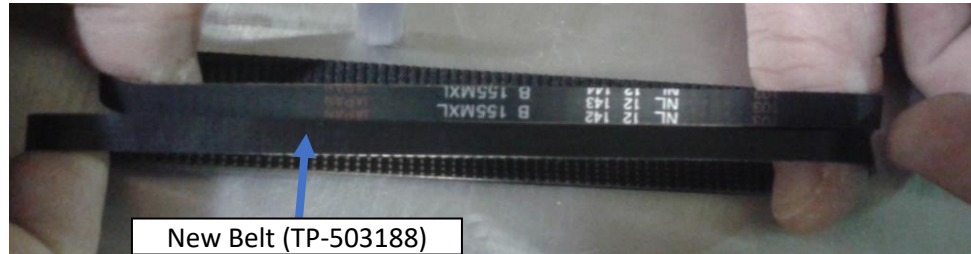

Install new Belt, install Motor Hardware, and tighten Tensioner. Replace PLC.

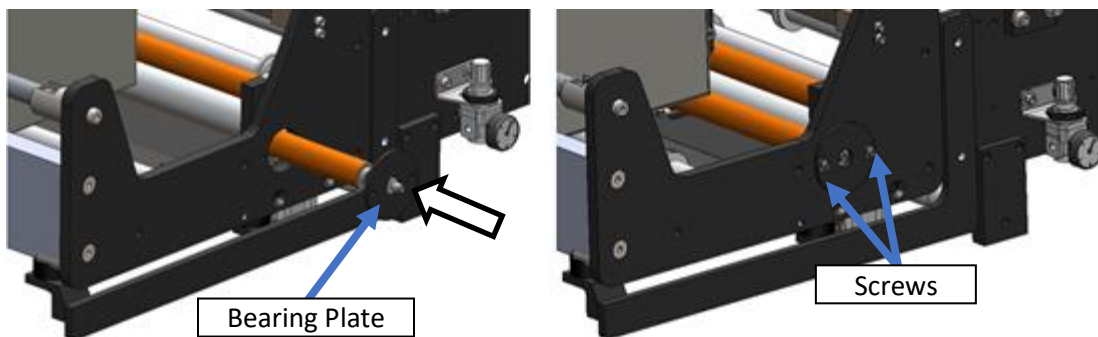

Move Print Head Roller back into place; reinstall screws in Bearing Plate. Reinstall Belt Cover.





# How To

## Service Documents from APPI

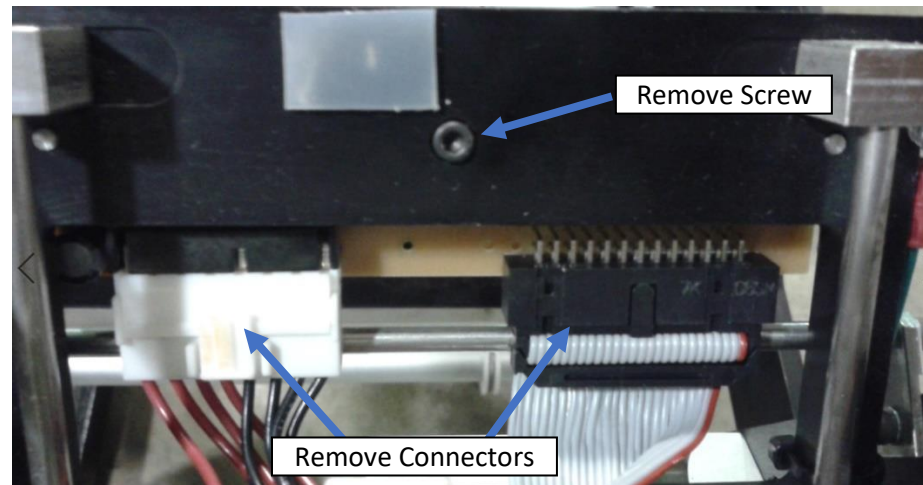

Remove Print Head connectors; remove Print Head by loosening screw (Note: This screw is Metric – 2.5mm – DO NOT LOSE).

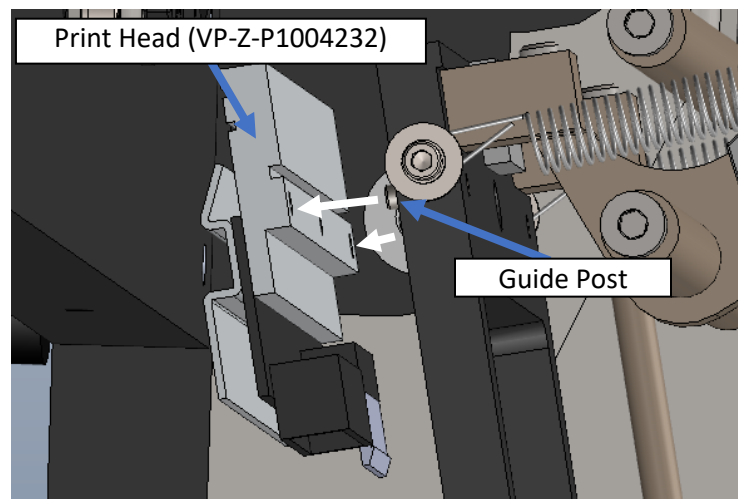

Install new Print Head, aligning to Guide Posts on Print Head Mounting Bracket. Re-install screw. Screw should be snug, but not too tight. If the screw is too tight, the Print Head can become distorted.



# How To

## Service Documents from APPI

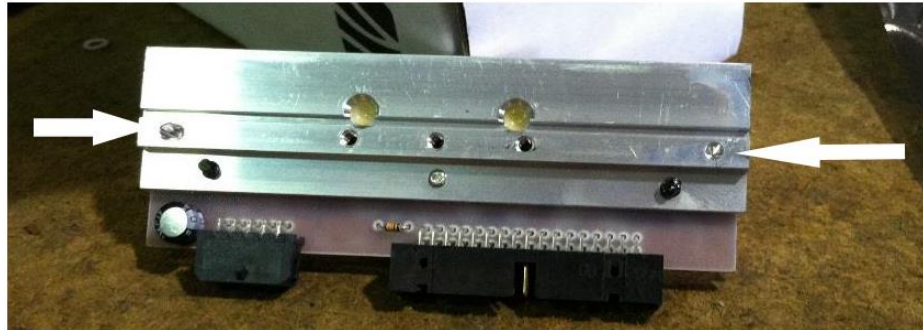

Alignment features on Print Head (above).  
Guide Posts on Mounting Bracket (below).

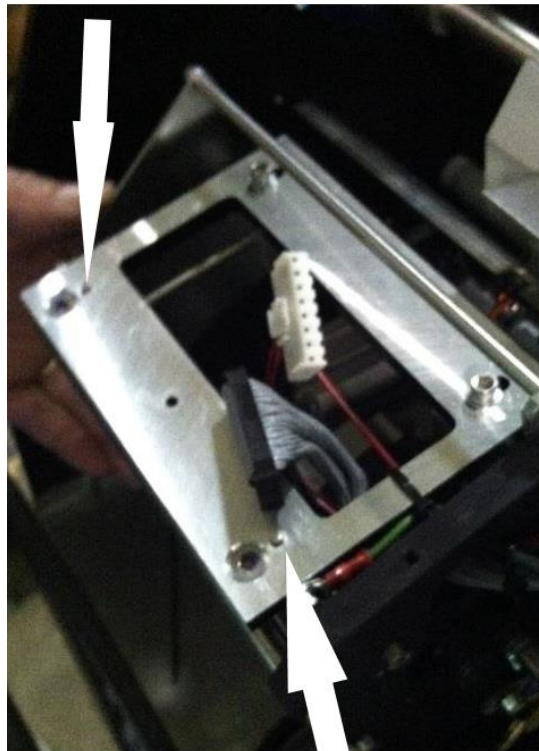





# How To

## Service Documents from APPI

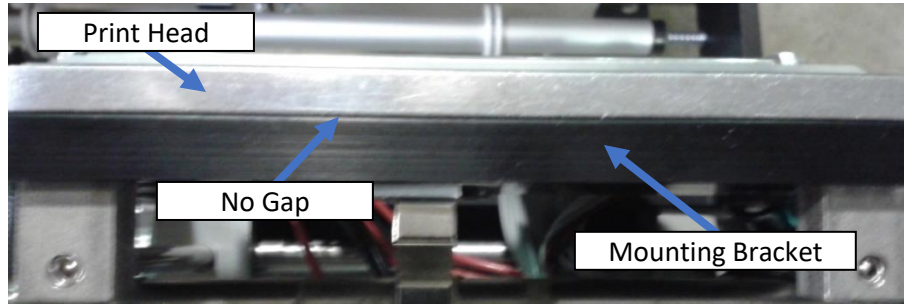

There should be no gap between Print Head and Bracket.

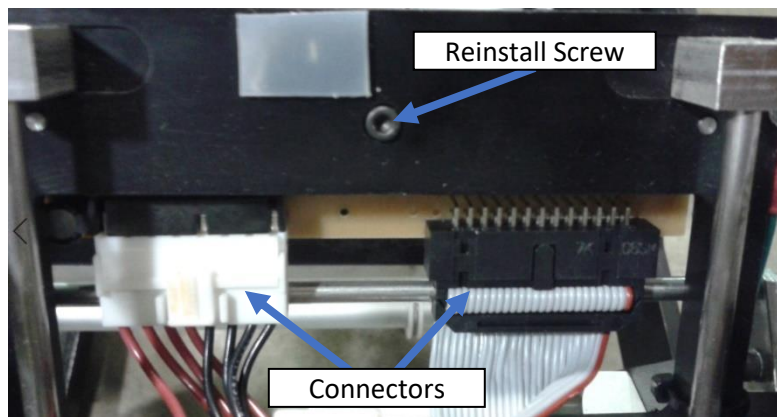

Plug in connectors.

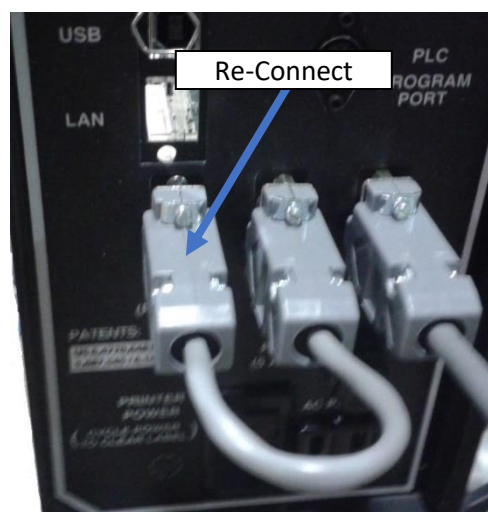

Replace Jumper Cable. Replace Side Cover.