

# Standard Options

---

Description: Bag Opening Device, 6-1/4" Pass-Through

P/N: TO-T1-BO30-6

Machine: T-1000

Manual Revision: 2



Advanced  
Poly-Packaging, Inc.

# Bag Opening Device for T-1000 6-1/4" Pass-Through

## TO-T1-BO30-6

ITEM NO.	QTY.	PART NO.	DESCRIPTION
1	1	TP-T1MBO30-16-1	ST-1000 LEFT GUARD FOR 6.25 PASS THRU
2	1	TP-T1MBO30-17-1	ST-1000 RIGHT GUARD FOR 6.25 PASS THRU
3	1	TP-T1MBO30A-11-2	LEXAN GUARD - 6.25 PASS THRU
4	1	TP-T1MBO30-10	CYLINDER GUARD
5	2	TP-107138	(2) BOLT FLANGE BEARING, 5/8" SHAFT
6	1	TP-403482	PNEUMATIC CYLINDER
7	1	TP-AF10130	LEVER ARM
8	1	TP-107400	5/8 BORE KEYLESS BUSHING
9	1	TP-BO30A-08	PIVOT SHAFT
10	2	TP-T1MBO30-4A1, 4B1	FINGER ASSEMBLY
11	1	TP-T1MBO30-2	MOUNT BLOCK
12	1	TP-T1MBBO30-32	BACKING PLATE
13	1	TP-401132	3-PORT TOGGLE VALVE
14	2	TP-401257	ELBOW, 1/4" TUBE X 1/8 NPT

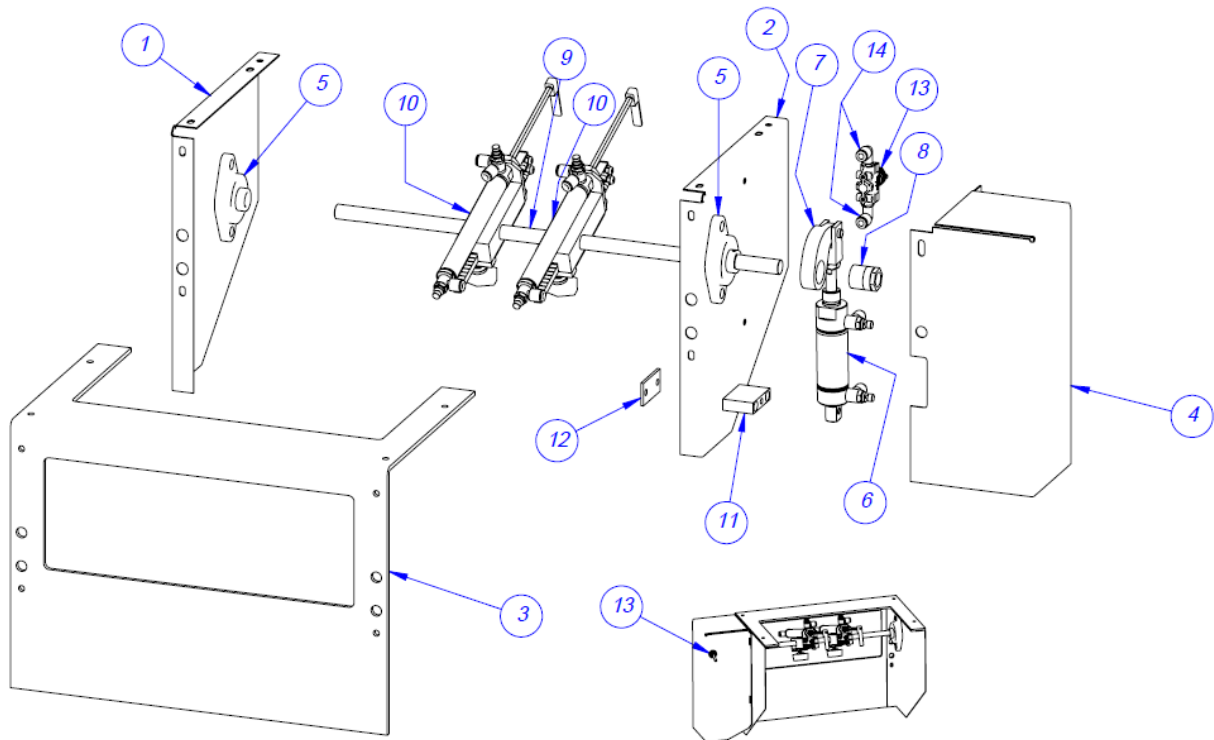

# Finger Assembly for T-1000 6-1/4" Pass-Through

## TO-T1-BO30-6

ITEM NO.	QTY.	PART NO.	DESCRIPTION
1	1	TP-T1MBO30-27	CYLINDER BLOCK
2	1	TP-T1MBO30-28	CYLINDER MOUNT
3	1	TP-T1MBO30-45	BLOCK PLATE
4	1	TP-T1MBO30-26	INSULATOR
5	2	TP-BO30A-14	TAB
6	1	TP-T1MBO30-30	ADJUST ROD
7	1	TP-T1MBO30-31	CLAMP BAR
8	1	TP-109240	KNOB
9	2	TP-402187	FLOW CONTROL
10	1	TP-403290	PNEUMATIC CYLINDER
11	1	TP-T1MBO30-4B1	FINGER
12	1	TP-208400	RING TERMINAL

