

Standard Options

Description: Bag Opening Device, 4.25" Pass-Through

P/N: TO-T1-BO30-4

Machine: T-1000

Manual Revision: 1



Bag Opening Device for T-1000 4-1/4" Pass-Through

TO-T1-BO30-4

ITEM NO.	QTY.	PART NO.	DESCRIPTION
1	1	TP-T1MBO30-6S	LEFT GUARD
2	1	TP-T1MBO30-7S	RIGHT GUARD
3	1	TP-T1MBO30A-11	LEXAN GUARD - 4.25 PASS THRU
4	1	TP-T1MBO30-10	CYLINDER GUARD
5	2	TP-107138	(2) BOLT FLANGE BEARING, 5/8" SHAFT
6	1	TP-403482	1" STROKE CYLINDER WITH MAGNET
7	1	TP-AF10130	LEVER ARM
8	1	TP-107400	5/8 BORE KEYLESS BUSHING
9	1	TP-BO30A-08	PIVOT SHAFT
10	2	TP-T1MBO30-2	MOUNT BLOCK
11	1	TP-T1MBBO30-32	BACKING PLATE
12	1	TP-T1MBO30-4A1, 4B1	FINGER ASSEMBLY
13	1	TP-401132	3-PORT TOGGLE VALVE
14	2	TP-401257	ELBOW, 1/4" TUBE, 1/8" NPT

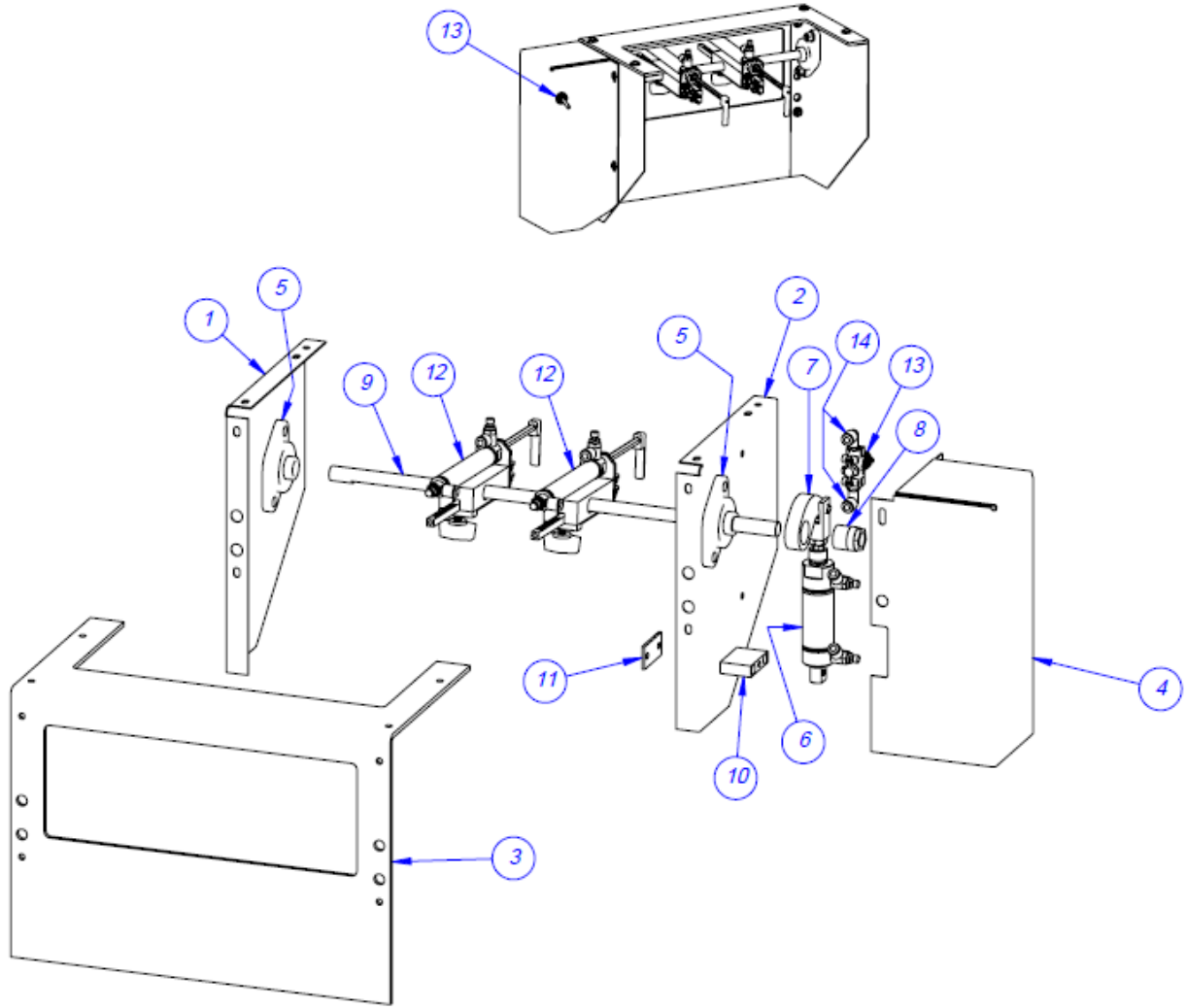

Finger Assembly for T-1000 4-1/4" Pass-Through

TO-T1-BO30-4

ITEM NO.	QTY.	PART NO.	DESCRIPTION
1	1	TP-T1MBO30-42	CYLINDER BLOCK
2	1	TP-T1MBO30-28	CYLINDER MOUNT
3	1	TP-T1MBO30-45	BLOCK PLATE
4	1	TP-T1MBO30-44	INSULATOR
5	2	TP-BO30A-14	TAB
6	1	TP-T1MBO30-30	ADJUST ROD
7	1	TP-T1MBO30-31	CLAMP BAR
8	1	TP-109240	KNOB
9	2	TP-402187	FLOW CONTROL
10	1	TP-403284	PNEUMATIC CYLINDER
11	1	TP-T1MBO30-4B-1	FINGER
12	2	TP-208400	TERMINAL

